



Parts Reference Catalog

INDEX



- 01 INDEX
- 02 CYLINDER
- 03 PISTON
- 04 CRANKSHAFT
- 05 COUNTERSHAFT
- 06 REED VALVE
- 07 CLUTCH
- 08 ENGINE STARTER
- 09 IGNITION
- 10 ELECTRONIC
- 11 ACCESSORIES
- 12 EXHAUST SILENCER
- 13 TOOLS

CATALOG 2019

02 - CYLINDER

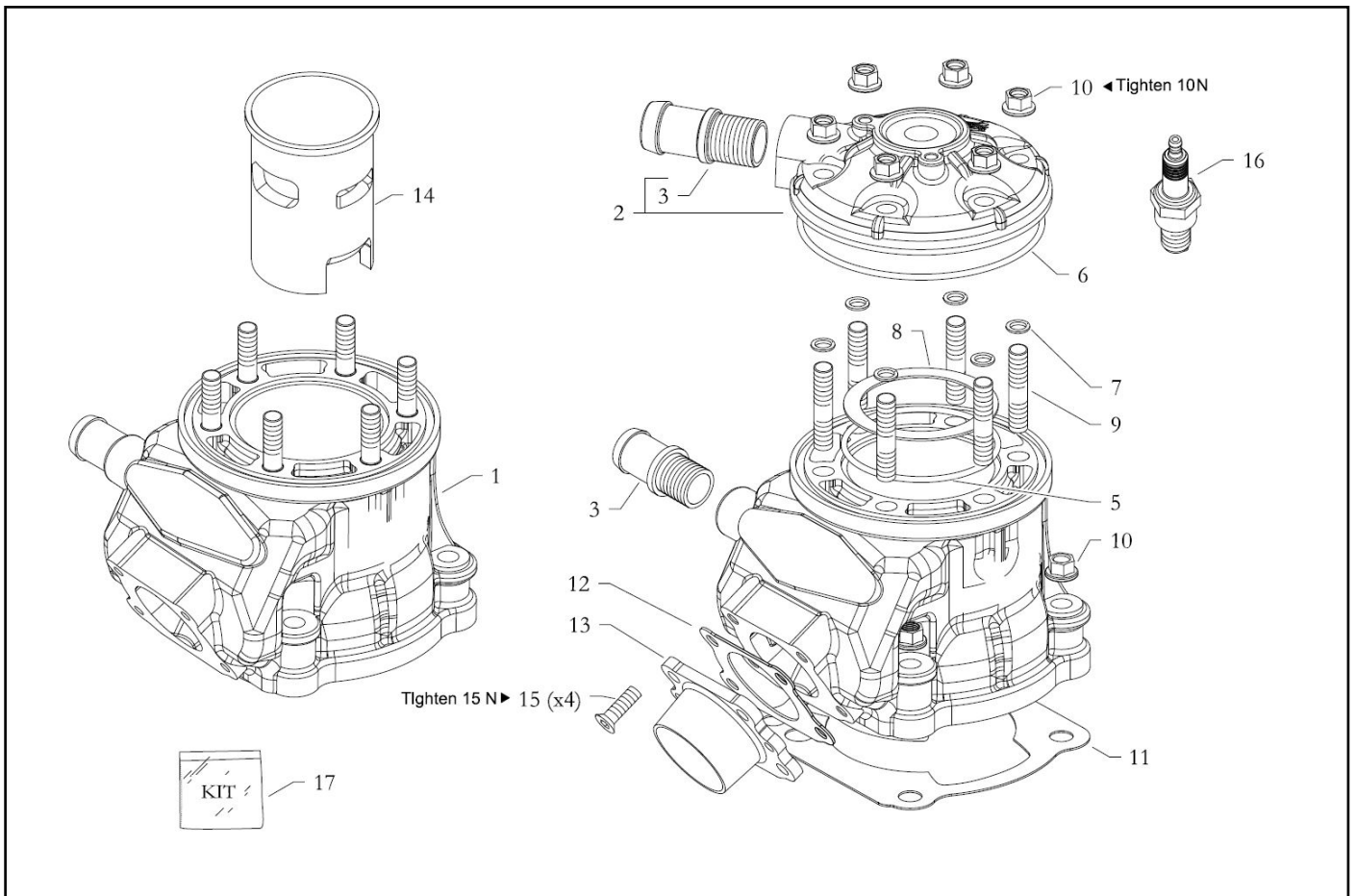

Pos	Code	Description
1	10.10079.00	CYLINDER HAT, ASSY.
2	10.10080.00	HEAD ENGINE
3	20.9918.10	WATERPIPE CONNECTION
5	40.9919.00	O-RING 2237 INNER CYLINDER
6	40.11157.00	O-RING 2400 101.32X1.78 VITON
6	40.11158.00	O-RING 100X2 OUTER CYLINDER VITON
6	40.9920.00	O-RING 2237 100X2.5 VITON OUTER CYLINDER
7	40.9921.00	O-RING 2031 SCREW STUD
8	20.9922.14	SHIM HEAD MOTOR 0,05MM
8	20.9923.27	SHIM HEAD MOTOR 0,1 MM
8	20.9924.27	SHIM HEAD MOTOR 0,2 MM
9	20.9925.06	SCREW STUD FIXING HEAD M8
10	40.9926.00	FLANGED NUT M8
11	20.10120.22	GASKET CYLINDER BASE 0,1 MM
11	20.10121.22	GASKET CYLINDER BASE 0,2 MM
11	20.10145.22	GASKET CYLINDER BASE 0,3 MM
11	20.10146.22	GASKET CYLINDER BASE 0,4 MM
12	20.9930.22	GASKET EXHAUST MANIFOLD
13	20.9903.10	EXHAUST MANIFOLD
14	20.10416.08	CYLINDER LINER
15	40.11175.00	SCREW COUNTERSUNK FLAT M5X20 TORX
16	10.11156.00	SPARK PLUG L8 S COLD
16	10.9884.00	SPARK PLUG L10S
17	10.9931.00	O-RING CYLINDER KIT

03 - PISTON

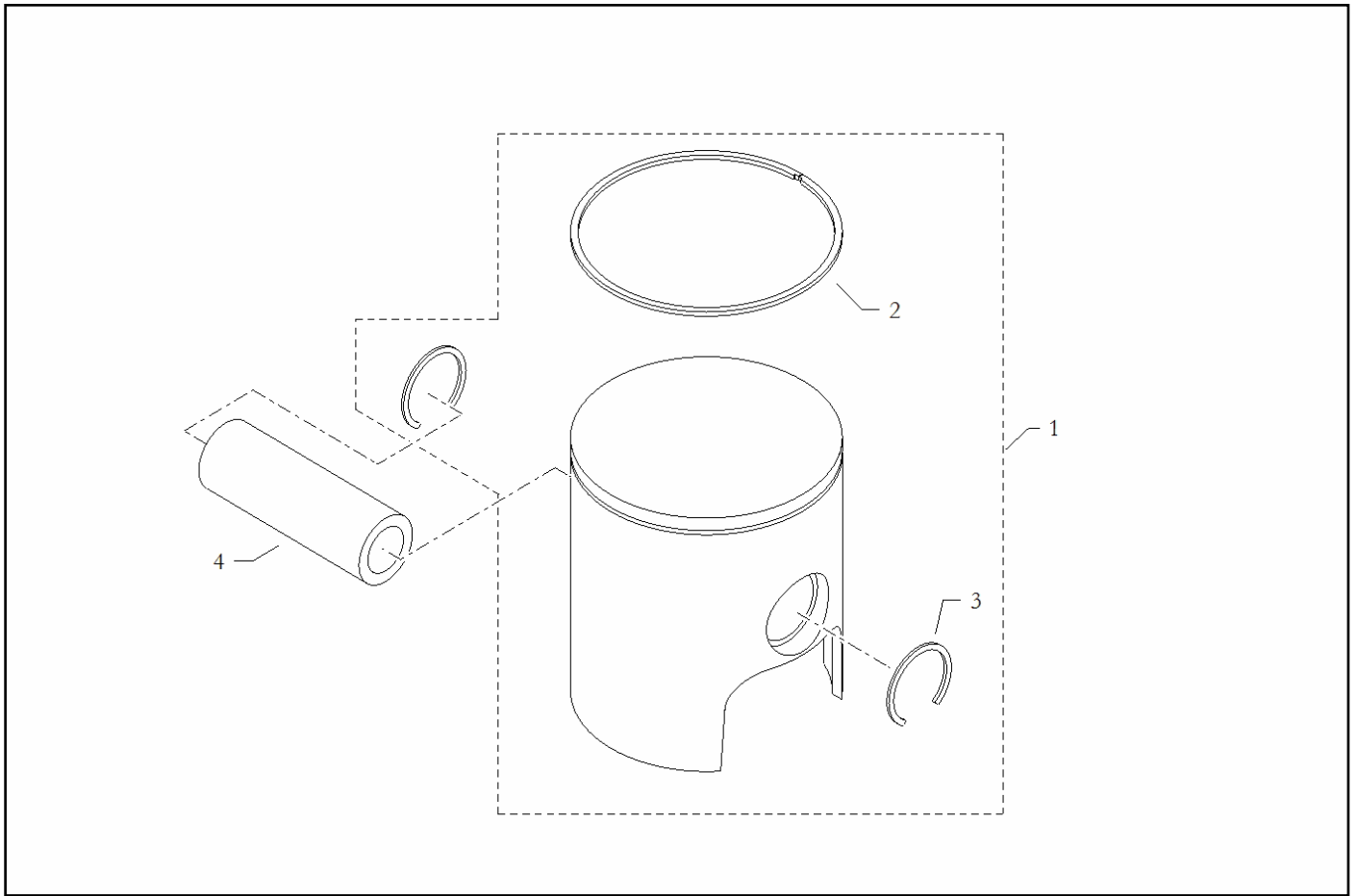

Pos	Code	Description
1	10.9434.00	PISTON 53.99, ASSY
1	10.9435.00	PISTON 54.03, ASSY
1	10.9436.00	PISTON 54.05, ASSY
1	10.9437.00	PISTON 54.07, ASSY
1	10.9438.00	PISTON 54.09, ASSY
1	10.9439.00	PISTON 54.11, ASSY
1	10.9440.00	PISTON 54.13, ASSY
1	10.9441.00	PISTON 54.15, ASSY
1	10.9442.00	PISTON 54.16, ASSY
1	10.9443.00	PISTON 54.17, ASSY
2	40.9478.00	PISTON RING 54.10
2	40.9479.00	PISTON RING 54.15
2	40.9480.00	PISTON RING 54.20
2	40.9481.00	PISTON RING 54.25
3	40.9433.00	STOP RING FOR PISTON PIN C
4	40.9432.00	PISTON PIN 14x45x10 BICONIC

04 - CRANKSHAFT

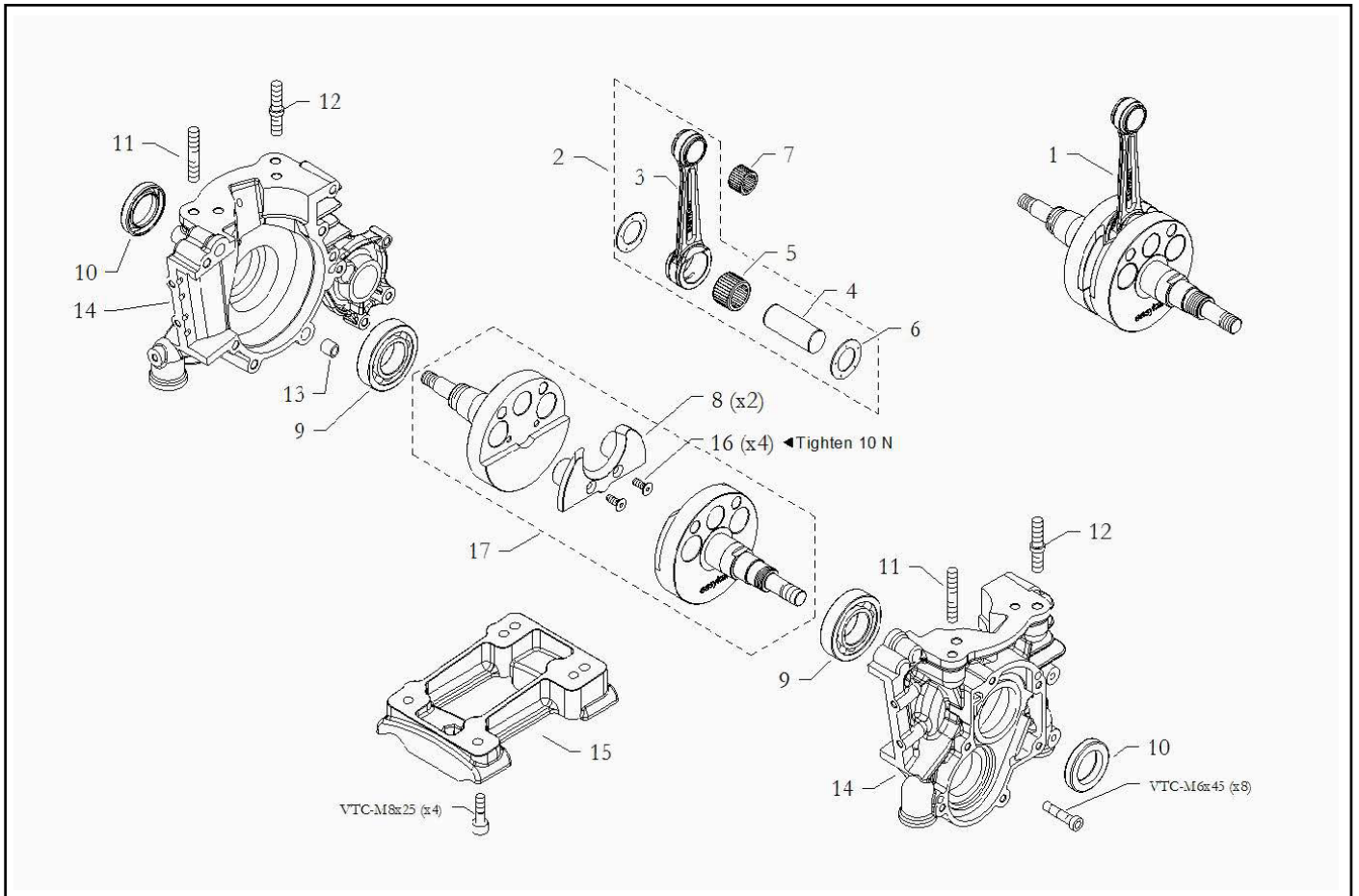

Pos	Code	Description
1	10.11077.00	CRANKSHAFT Ø 20, ASSY.
2	10.11078.00	CONROD Ø 20, ASSY.
3	20.11079.06	CONROD Ø 20
4	20.11080.06	CRANKPIN Ø 20 L=47
5	40.7947.00	ROLLER CAGE 20x26x15
6	40.7949.00	WASHER SILVER 20x35x1
7	40.11062.00	ROLLER CAGE 14x18x20
8	20.9111.18	FILLING SHAFT
9	40.7929.00	BEARING 6205 ETN9 25x52x15 C4
10	40.9265.00	OIL SEAL 25x40x7
11	20.10663.06	SCREW STUD CYLINDER INLET SIDE M8x60
12	20.10662.06	SCREW STUD CYLINDER EXHAUST SIDE M8x58
13	20.9963.06	SCREW STUD CARTER, SIDE INLEAT
14	10.8946.00	CARTER ENGINE, ASSEMBLY
15	10.10684.00	ENGINE MOUNT MAGNESIUM
15	10.8926.00	ENGINE MOUNT INCLINED
16	40.11173.00	SCREW COUNTERSUNK FLAT M5X10 TORX
17	10.11420.00	COUPLE SHAFT Ø 20

05 - COUNTERSHAFT

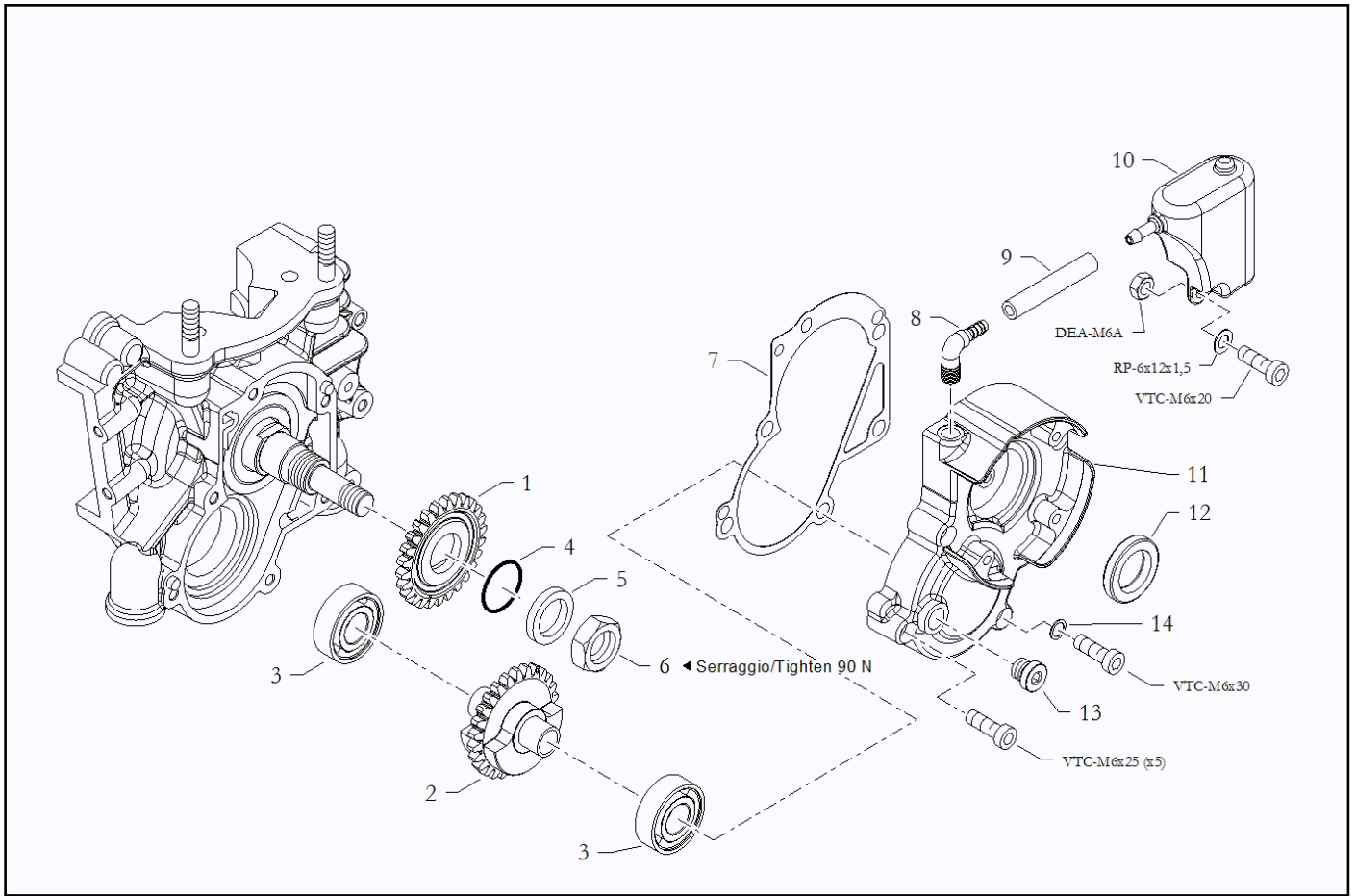

Pos	Code	Description
1	20.9290.06	BALANCED GEAR SHAFT
2	20.9289.06	COUNTERSHAFT
3	40.9304.00	BEARING 6202 TN1 15x35x11 C4
4	40.11089.00	GROMMET OR 20x1,5 NBR
5	20.9497.06	STOP GEAR WASHER
6	20.9445.06	NUT GEAR COUNTERSHAFT
7	20.9276.22	GASKET CRANKCASE COUNTERSHAFT
8	40.9245.00	CONNECTOR VACUUM
9	20.9444.20	OIL BREATHER PIPE L=59.5
10	20.9244.18	OVER FLOW BOTTLE ENGINE
11	20.8933.10	CRANKCASE COUNTERSHAFT
12	40.7936.00	OIL SEAL 26x35x7
13	40.4270.00	CYLINDRICAL CAP
14	40.8500.00	COPPER WASHER 6X10X1,5

06 - REED VALVE

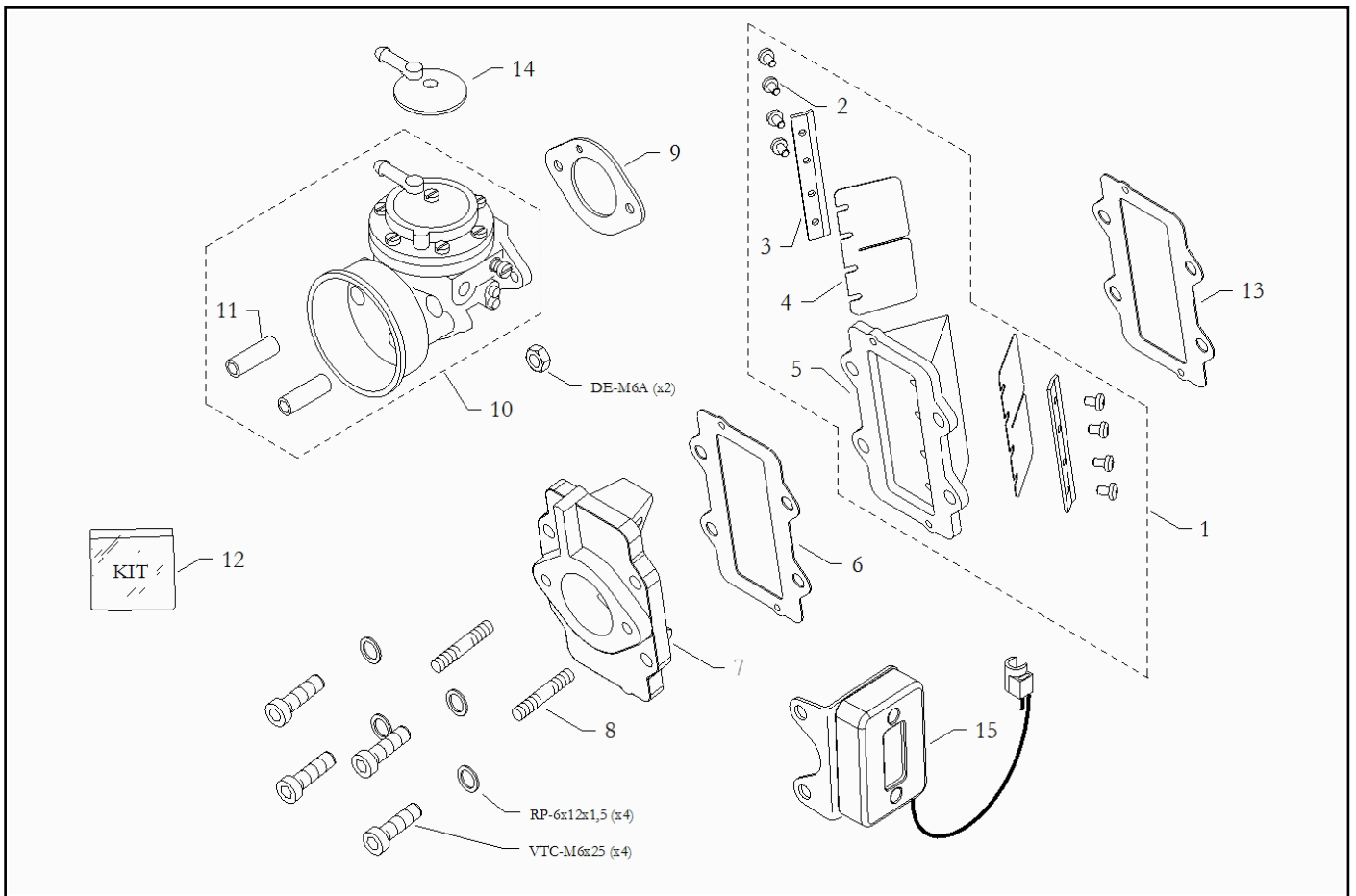

Pos	Code	Description
1	10.9653.00	REED VALVE
2	40.9652.00	REEDS SCREW
3	40.9651.00	REEDS CLIP
4	40.13783.00	PAIR REED PETALS CARBON IM
6	20.9239.22	REED VALVE BARE GASKET
7	40.9456.00	CONVEYOR CARBURETOR
8	20.11076.06	SCREW M6x28
9	20.9242.22	CARBURETTOR GASKET
10	40.10144.00	CARBURETTOR TRYTON MOD.HB-27
11	20.10147.06	STUD M6
12	10.10183.00	OVERHAUL CARBURETTOR TRYTON HB-27 KIT
13	20.10402.22	REED VALVE GASKET
14	40.11421.00	COVER CARBURATOR TRYTON HB-27
15	10.11587.00	HOUR-METER , ASSY.

07 - CLUTCH

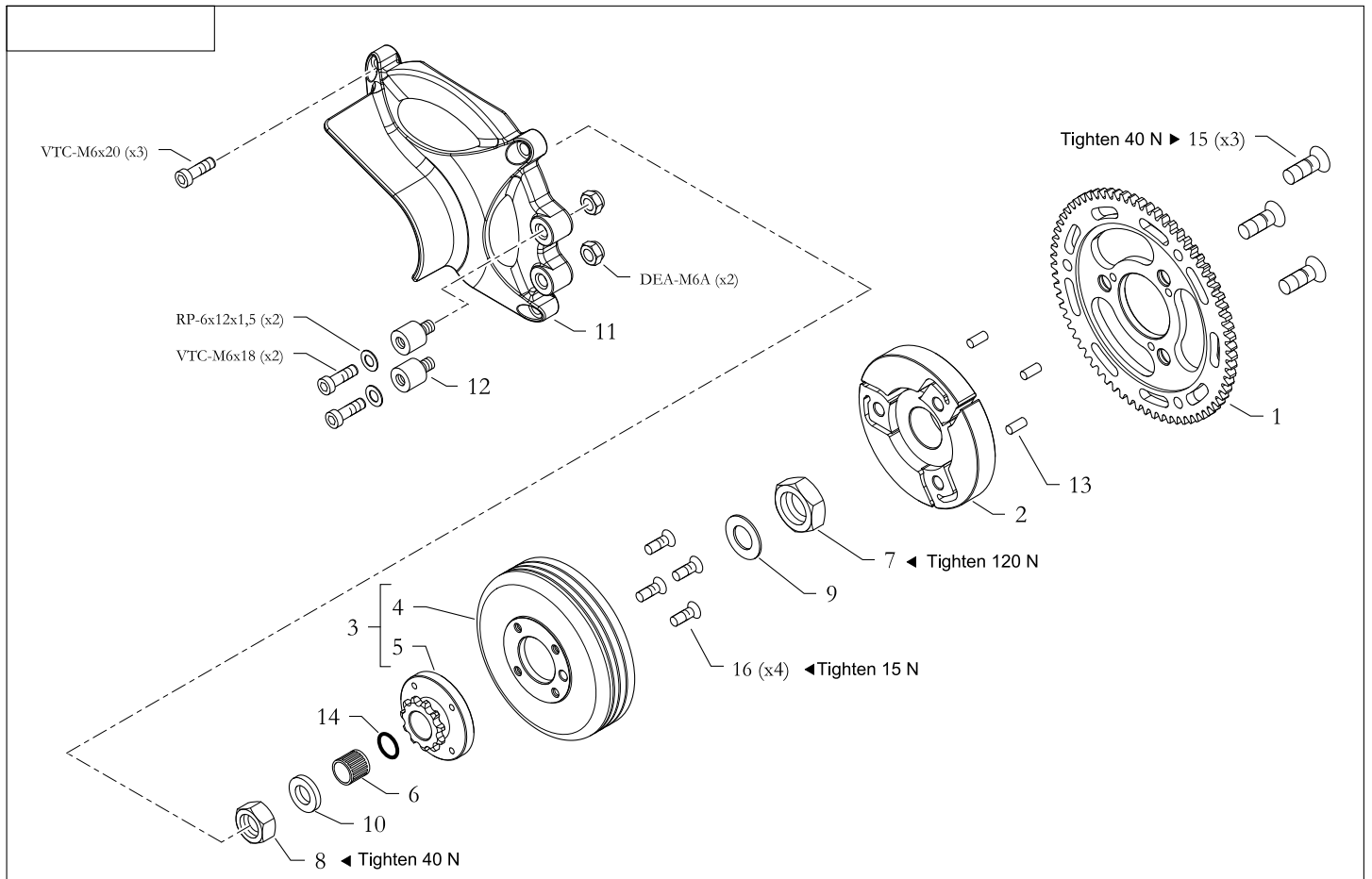

Pos	Code	Description
1	20.10186.06-BR	STARTER DRIVER WHEEL Z-70
2	20.9447.06	CLUTCH
3	10.9450.00	CLUTCH BELL Z11, ASSY
4	20.9336.06-BR	CLUTCH BELL EK
5	20.9346.06	SPROCKET Z10
5	20.9449.06	SPROCKET Z11
5	2010001.00	SPROCKET Z12
5	20.10002.06	SPROCKET Z13
6	40.10620.00	ROLLER CAGE 12x15x15
7	20.9448.06	CLUTCH NUT M20x1
8	40.11153.00	NUT M10X1
9	20.9380.06	WASHER 12x20x1.7
10	20.9379.06	SPROCKET WASHER 10x17x4
11	20.9262.18-RO	CLUTCH COVER
12	40.8033.00	ANTI-VIBRATION DAMPER 15x15 M6MF
13	40.10495.00	CYLINDRICAL PIN 4x10 DIN 6325
14	40.10636.00	GROMMET OR 114 D.I. 11,11x1,78 VITON ROSSO
15	40.11172.00	SCREW COUNTERSUNK FLAT M8X16 TORX
16	40.11174.00	SCREW COUNTERSUNK FLAT M5X8 TORX

08 - ENGINE STARTER

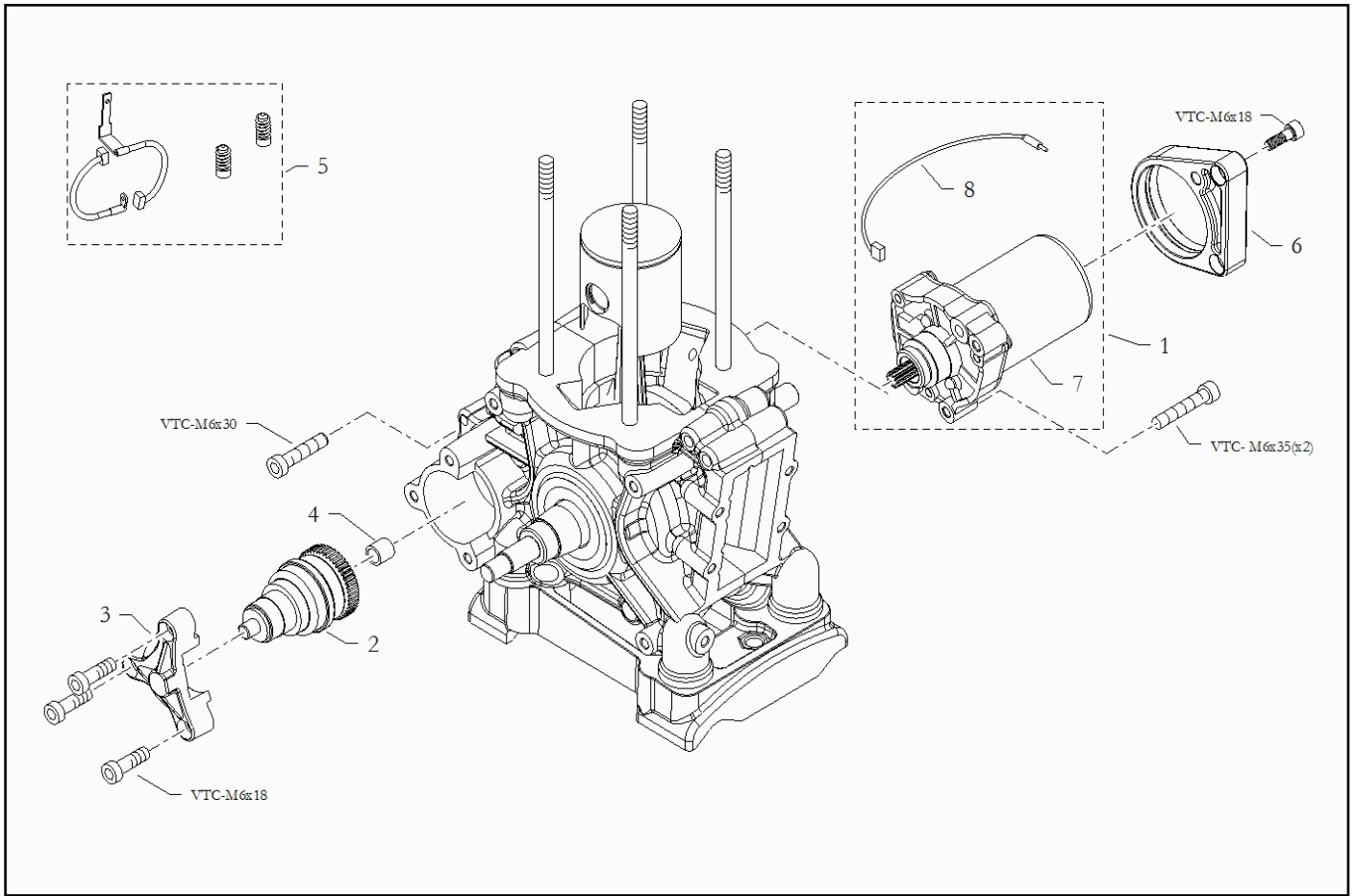

Pos	Code	Description
1	10.11564.00	ENGINE STARTER
2	40.9464.00	BENDIX
3	20.9175.18-GR	BENDIX COVER
4	40.9382.00	BEARING 8x10x12
5	10.10010.00	KIT OF BRUSHES FOR STARTER
6	20.8934.18-GR	SUPPORT CLAMP ENGINE STARTER
8	10.11444.00	BRUSH WIRED REINFORCED

09 - IGNITION

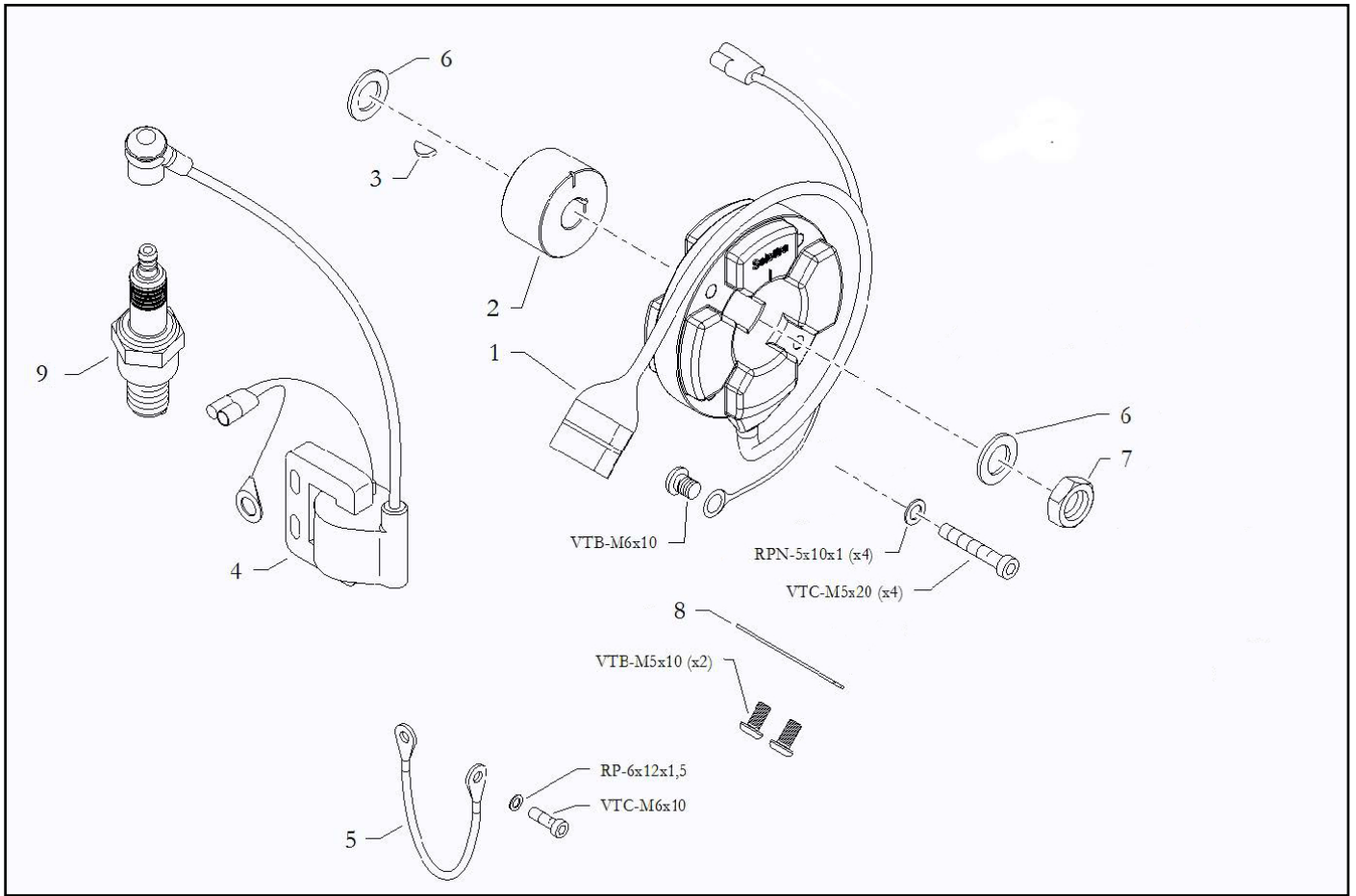

Pos	Code	Description
1	10.13687.00	STATOR DIG.S ROTOR AND STATOR
2	40.7893.00	ROTOR D.36x12 3P 68° LEFT
3	40.8067.00	WOODRUFF KEY 2.5x3.7 UNI-6606
4	40.13698.00	COIL - X125WC
5	10.8711.00	GROUND CABLE
6	40.9042.00	WASHER 12x18x1
7	20.7833.06	IGNITION NUT M12x1 H6
8	20.9177.06	SUPPORT CONNECTOR IGNITION CARTER
9	10.11156.00	SPARK PLUG L8 S COLD
9	10.9884.00	SPARK PLUG L10S

10 - ELECTRONIC

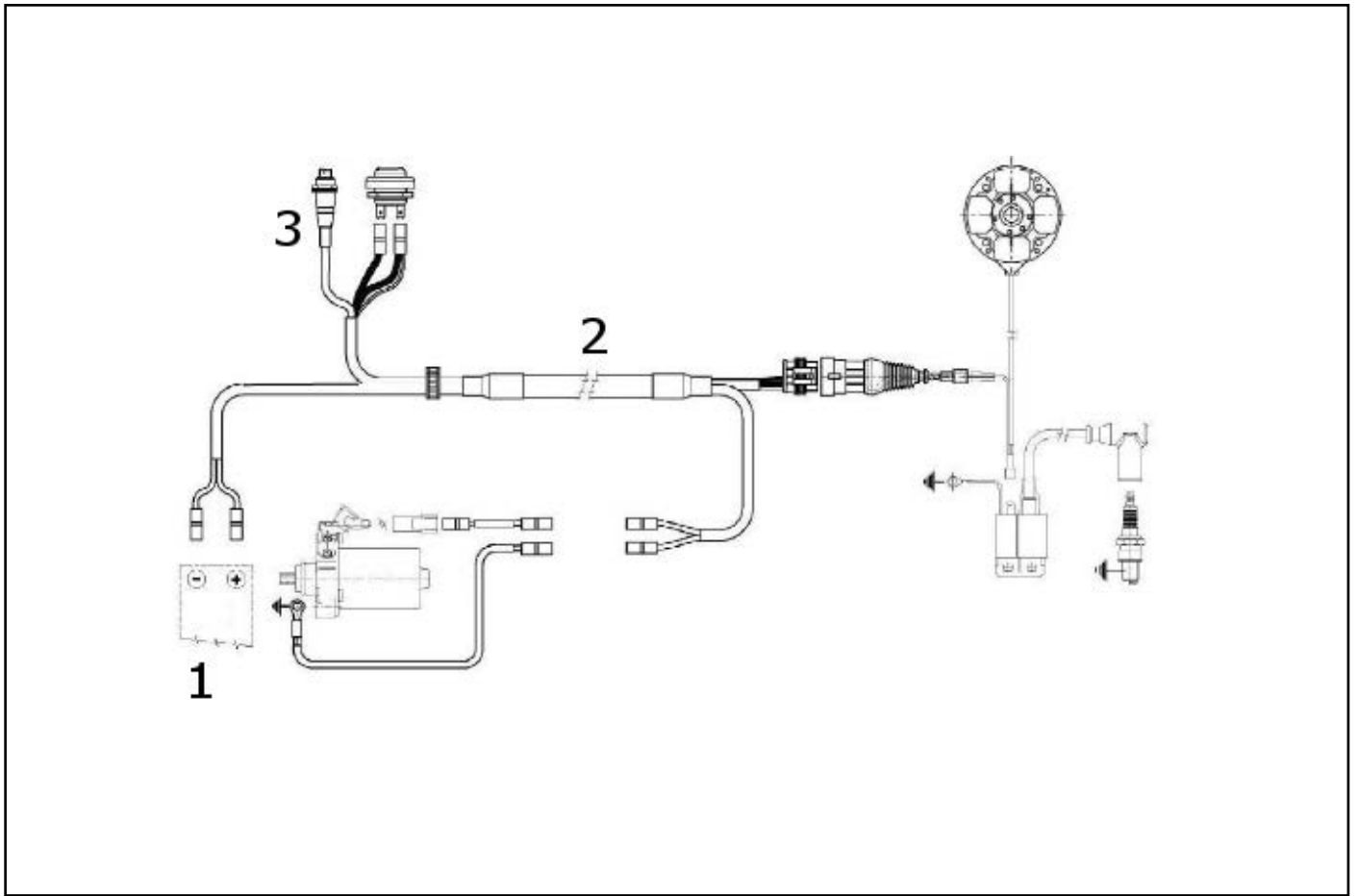

Pos	Code	Description
1	40.13676.00	BATTERY 12V
	10.13946.00	BATTERY SUPPORT
2	40.16390.00	MAIN WIRING
3	40.13691.00	START BUTTON KIT

10 - COOLING / RADIATOR

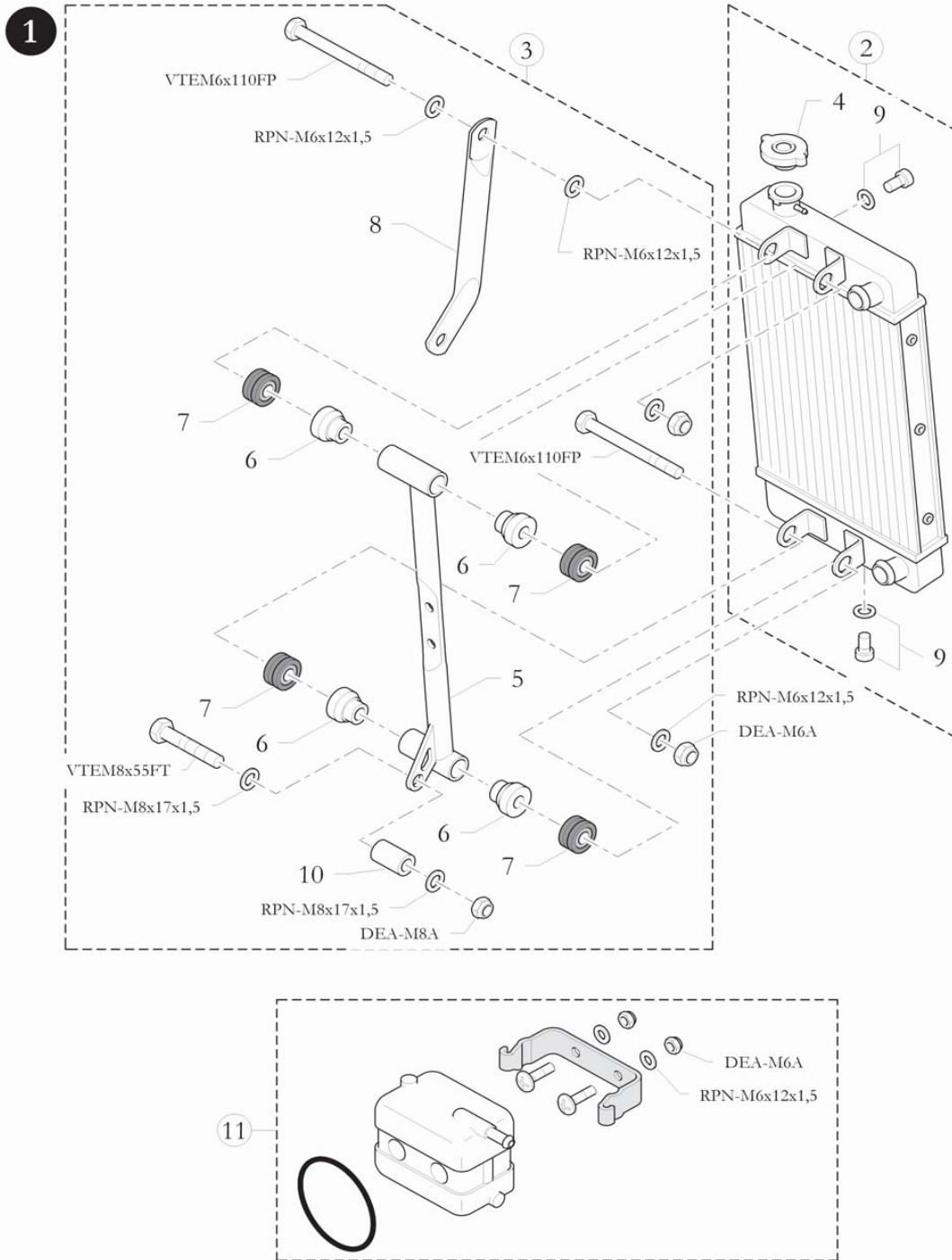

Pos	Code	Description
1	10.13497.00	RADIATOR AND BRACKET KIT
2		RADIATOR
3		RADIATOR BRACKET KIT
4		RADIATOR CAP
5		RADIATOR BRACKET - MAIN BRACKET
6		RADIATOR BUSHING
7		RADIATOR DAMPENER
8		RADIATOR BRACKET - UPPER ANGLED BRACKET
9		RADIATOR FILLING/DRAINING BOLT/WASHER
10		RADIATOR BRACKET TUBE
11		OVERFLOW TANK ASSEMBLY

11 - COOLING / HOSES AND PUMP

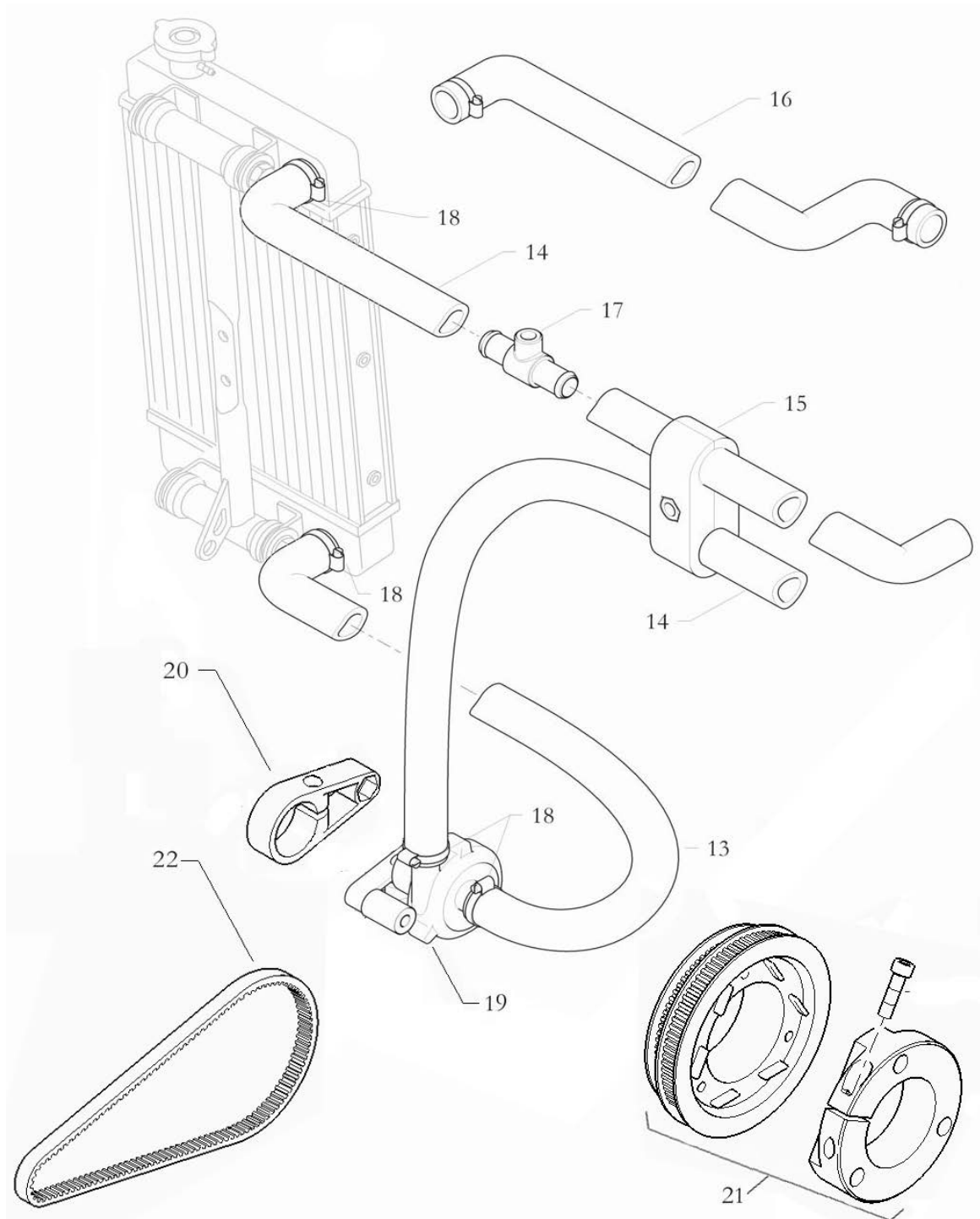

Pos Code	Description
10.12940.00	RADIATOR TUBE ASSEMBLY - INCLUDES #13 to #19
13 20.4008.20	RADIATOR HOSE "U"
14 20.3927.20	RADIATOR HOSE "L"
15 20.4016.18	RADIATOR HOSE COUPLING MOUNT
16 20.9848.20	RADIATOR HOSE "S"
17 10.4678.00	RADIATOR WATER PROBE FITTING
18 40.5884.00	HOSE CLAMP 19-28/9
19 6551.00.01	WATER PUMP
20 10.5792.00	WATER PUMP MOUNTING BRACKET
21 10.7769.00-NE	WATER PUMP PULLEY ASSEMBLY - 50mm
22 40.6157.20	WATER PUMP PULLEY TOOTHED BELT

12 - EXHAUST SILENCER

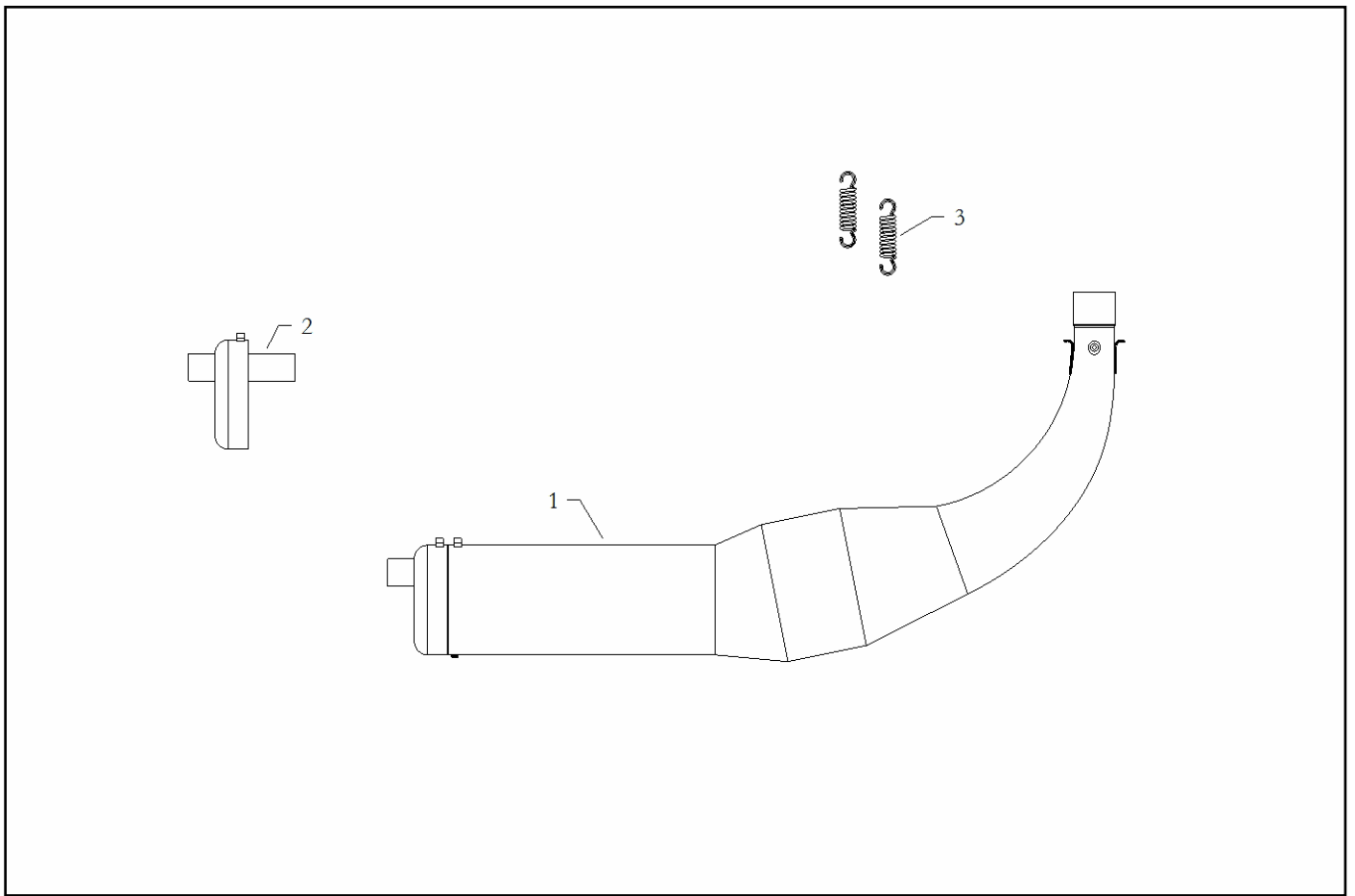

Pos Code	Description
1 10.10003.00	EXHAUST SILENCER
2 20.10006.06	SILENCER END
3 20.10768.06	EXHAUST SPRING L.45

13 - TOOLS

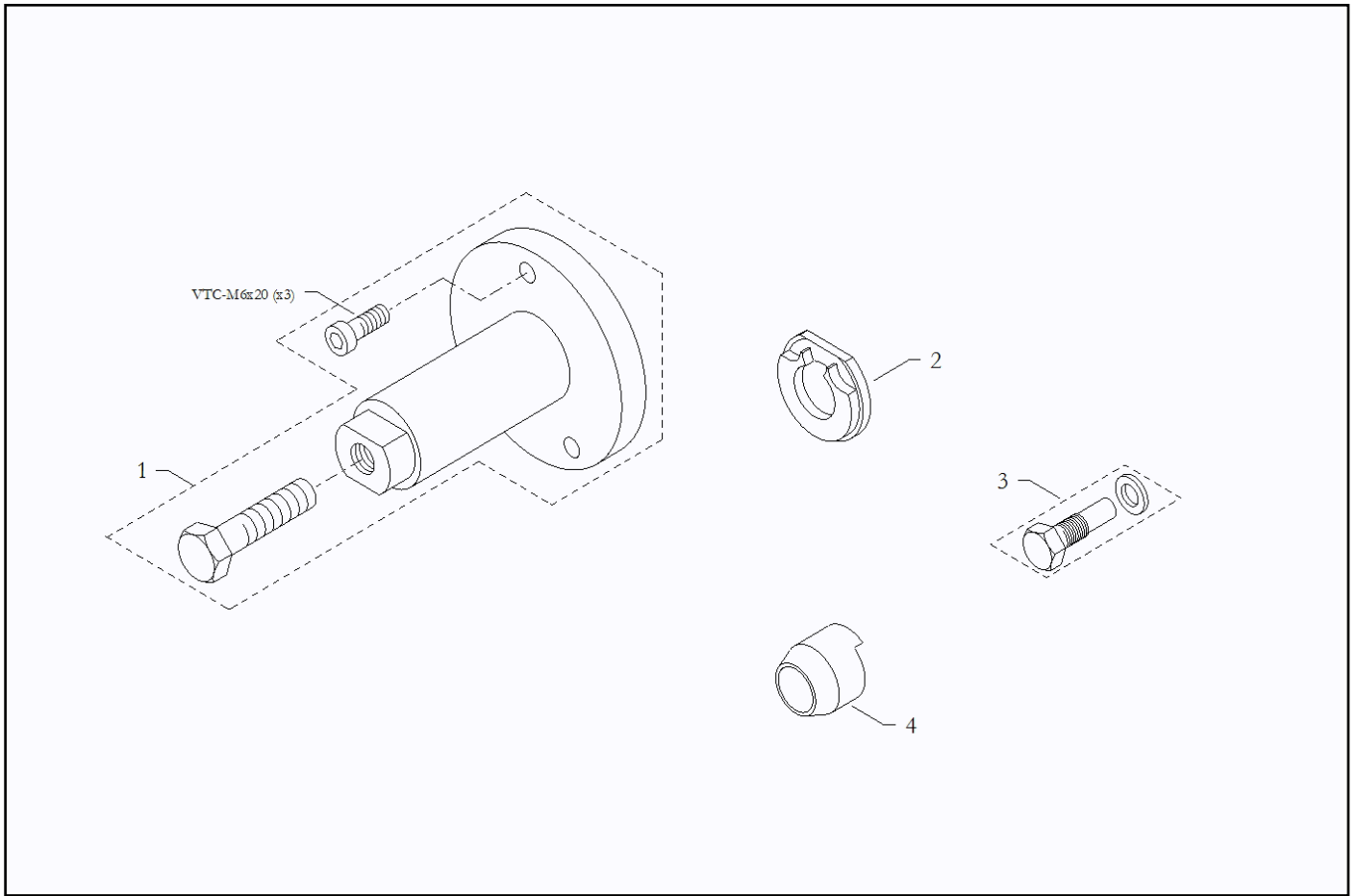

Pos	Code	Description
1	10.9681.00	CLUTCH PULLER
2	20.9782.06	STARTER DRIVER WHEEL PULLER
3	10.9784.00	COUNTERSHAFT PULLER
4	20.9785.06	BUSHING CRANKSHAFT OIL SEAL FITTING