

Parts Reference Catalog

INDEX

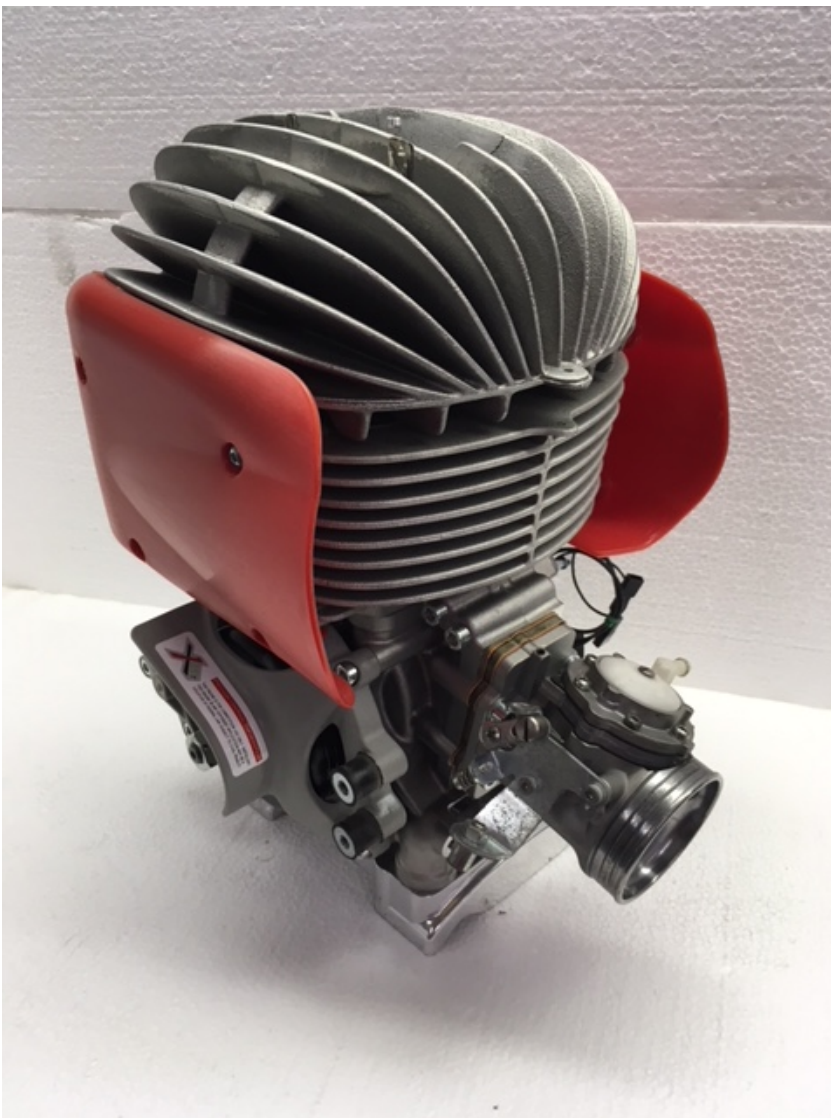

- 01 INDEX
- 02 CYLINDER
- 03 PISTON
- 04 CRANKSHAFT
- 05 COUNTERSHAFT
- 06 REED VALVE
- 07 CLUTCH
- 08 ENGINE STARTER
- 09 IGNITION
- 10 ELECTRONIC
- 11 ACCESSORIES
- 12 EXHAUST SILENCER
- 13 TOOLS

CATALOG 2020



02 - CYLINDER

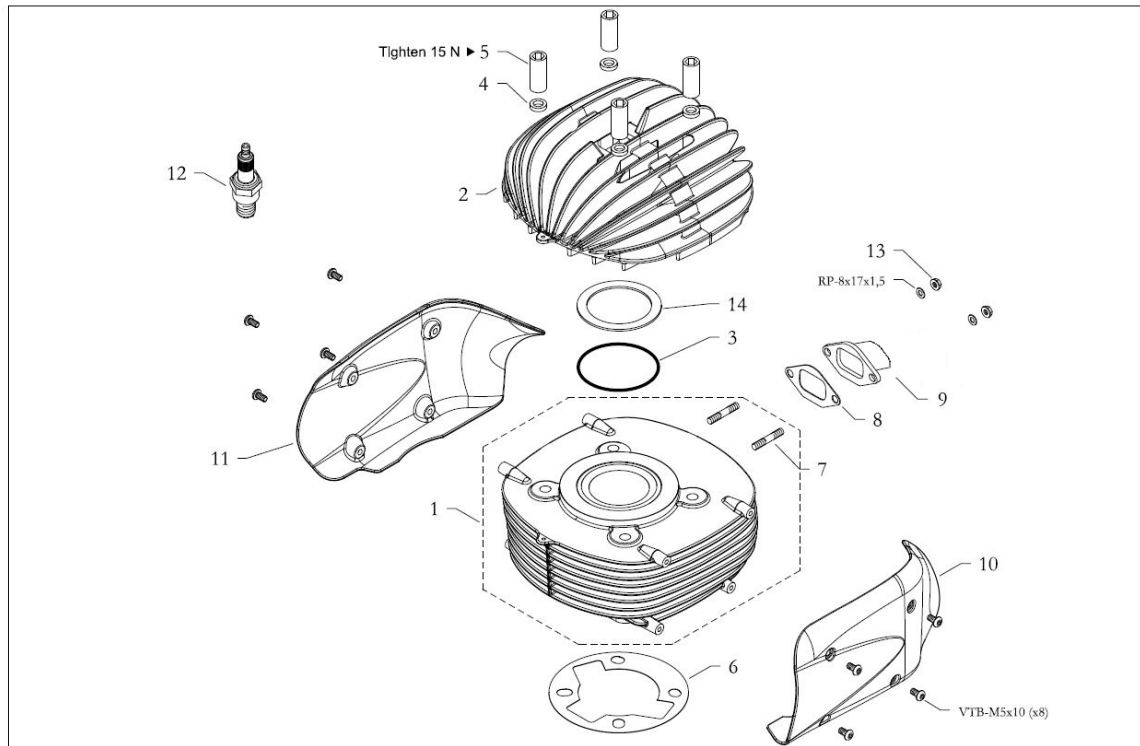

Pos	Code	Description
1	10.13667.00	Cylinder
2	20.13666.10	Cylinder Head
3	40.9499.00	Head ORing 2250 63,22x1,78
4	20.3729.06	Washer 8x15x3
5	20.11171.06	Nut M8x30
6	20.11674.22	Cylinder Base Gasket 0.1mm
6	20.11675.22	Cylinder Base Gasket 0.2mm
6	20.9231.22	Cylinder Base Gasket 0.3mm
6	20.9656.22	Cylinder Base Gasket 0.4mm
7	20.9453.06	Exhaust Stud M8x32
8	20.9273.22	Exhaust Gasket
9	20.14232.06	Exhaust Manifold
9	20.14233.06	Exhaust Manifold - Restricted 22mm
10	20.9038.18	Cylinder Side Cover - Left
11	20.9037.18	Cylinder Side Cover - Right
12	10.9884.00	Spark Plug - Brisk L10S
13	40.6257.00	Flanged Self-Locking Nut M8
14	20.11704.14	Cylinder Head Shim 0.05mm
14	20.11705.27	Cylinder Head Shim 0.1mm
14	20.11706.27	Cylinder Head Shim 0.2mm

03 - PISTON

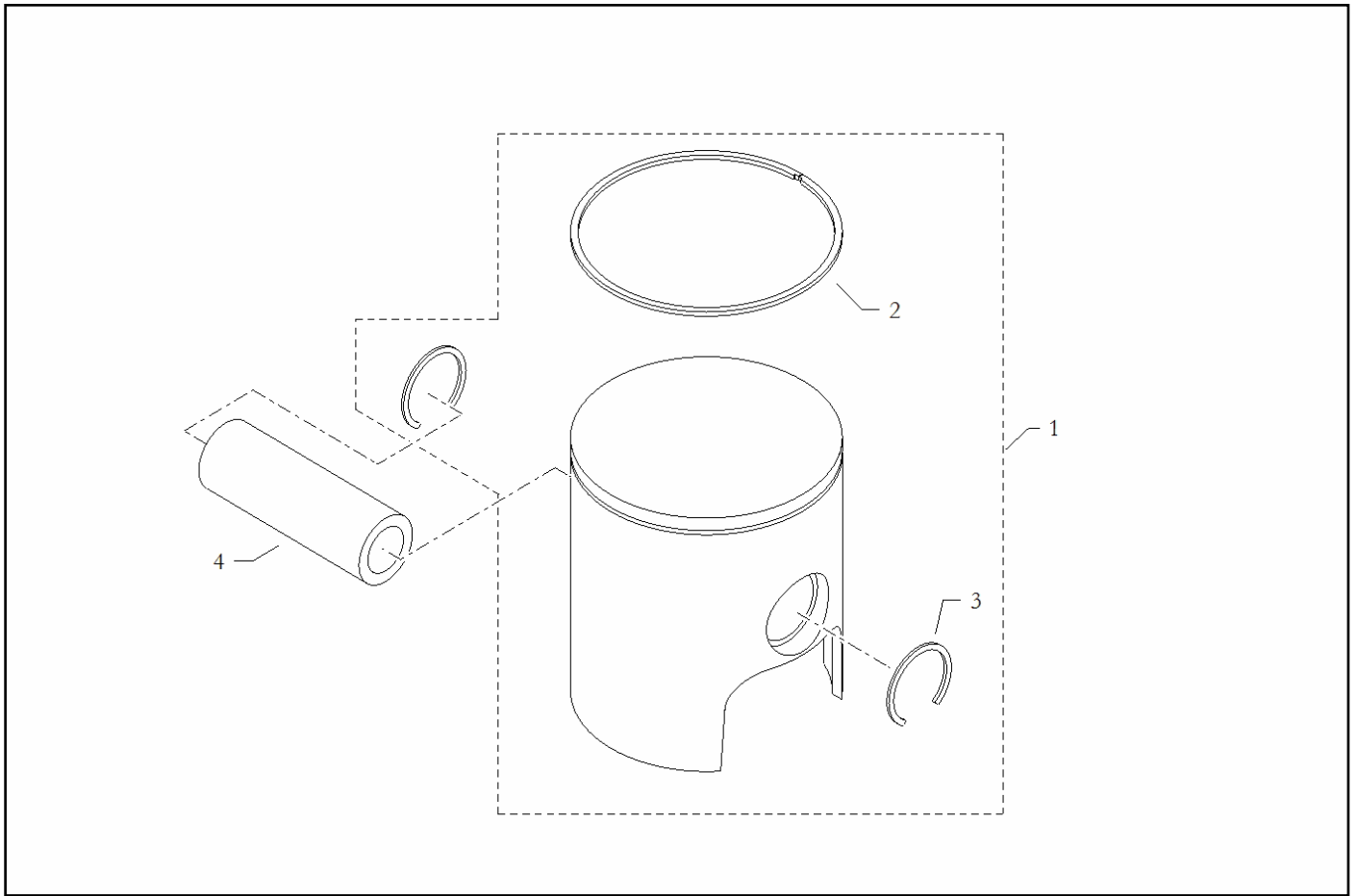

Pos	Code	Description
1	10.9434.00	PISTON 53.99, ASSY
1	10.9435.00	PISTON 54.03, ASSY
1	10.9436.00	PISTON 54.05, ASSY
1	10.9437.00	PISTON 54.07, ASSY
1	10.9438.00	PISTON 54.09, ASSY
1	10.9439.00	PISTON 54.11, ASSY
1	10.9440.00	PISTON 54.13, ASSY
1	10.9441.00	PISTON 54.15, ASSY
1	10.9442.00	PISTON 54.16, ASSY
1	10.9443.00	PISTON 54.17, ASSY
2	40.9478.00	PISTON RING 54.10
2	40.9479.00	PISTON RING 54.15
2	40.9480.00	PISTON RING 54.20
2	40.9481.00	PISTON RING 54.25
3	40.9433.00	STOP RING FOR PISTON PIN C
4	40.9432.00	PISTON PIN 14x45x10 BICONIC

04 - CRANKSHAFT

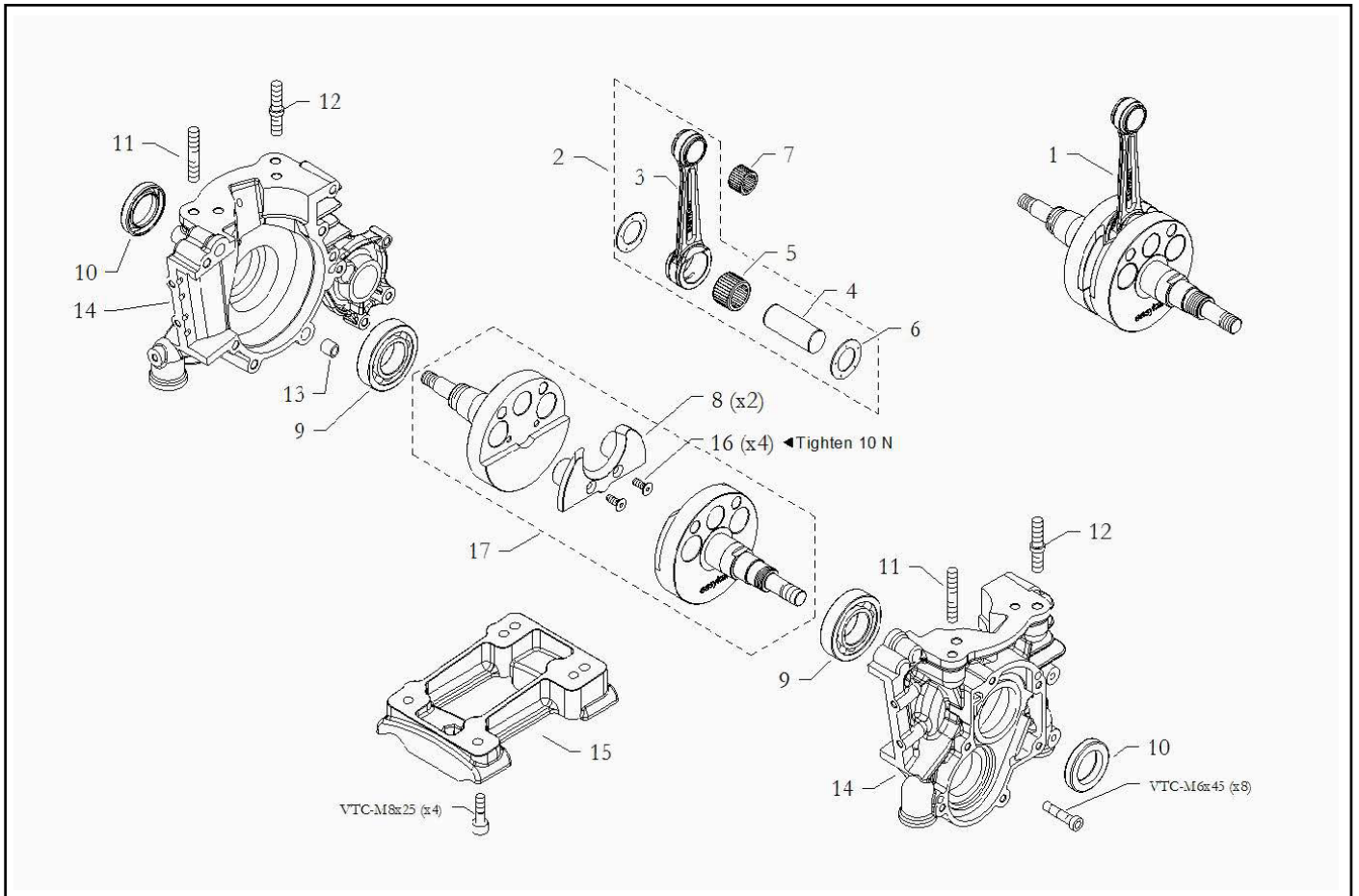

Pos	Code	Description
1	10.11077.00	CRANKSHAFT Ø 20, ASSY.
2	10.11078.00	CONROD Ø 20, ASSY.
3	20.11079.06	CONROD Ø 20
4	20.11080.06	CRANKPIN Ø 20 L=47
5	40.7947.00	ROLLER CAGE 20x26x15
6	40.7949.00	WASHER SILVER 20x35x1
7	40.11062.00	ROLLER CAGE 14x18x20
8	20.9111.18	FILLING SHAFT
9	40.7929.00	BEARING 6205 ETN9 25x52x15 C4
10	40.9265.00	OIL SEAL 25x40x7
11	20.10663.06	SCREW STUD CYLINDER INLET SIDE M8x60
12	20.10662.06	SCREW STUD CYLINDER EXHAUST SIDE M8x58
13	20.9963.06	SCREW STUD CARTER, SIDE INLEAT
14	10.8946.00	CARTER ENGINE, ASSEMBLY
15	10.10684.00	ENGINE MOUNT MAGNESIUM
15	10.8926.00	ENGINE MOUNT INCLINED
16	40.11173.00	SCREW COUNTERSUNK FLAT M5X10 TORX
17	10.11420.00	COUPLE SHAFT Ø 20

05 - COUNTERSHAFT

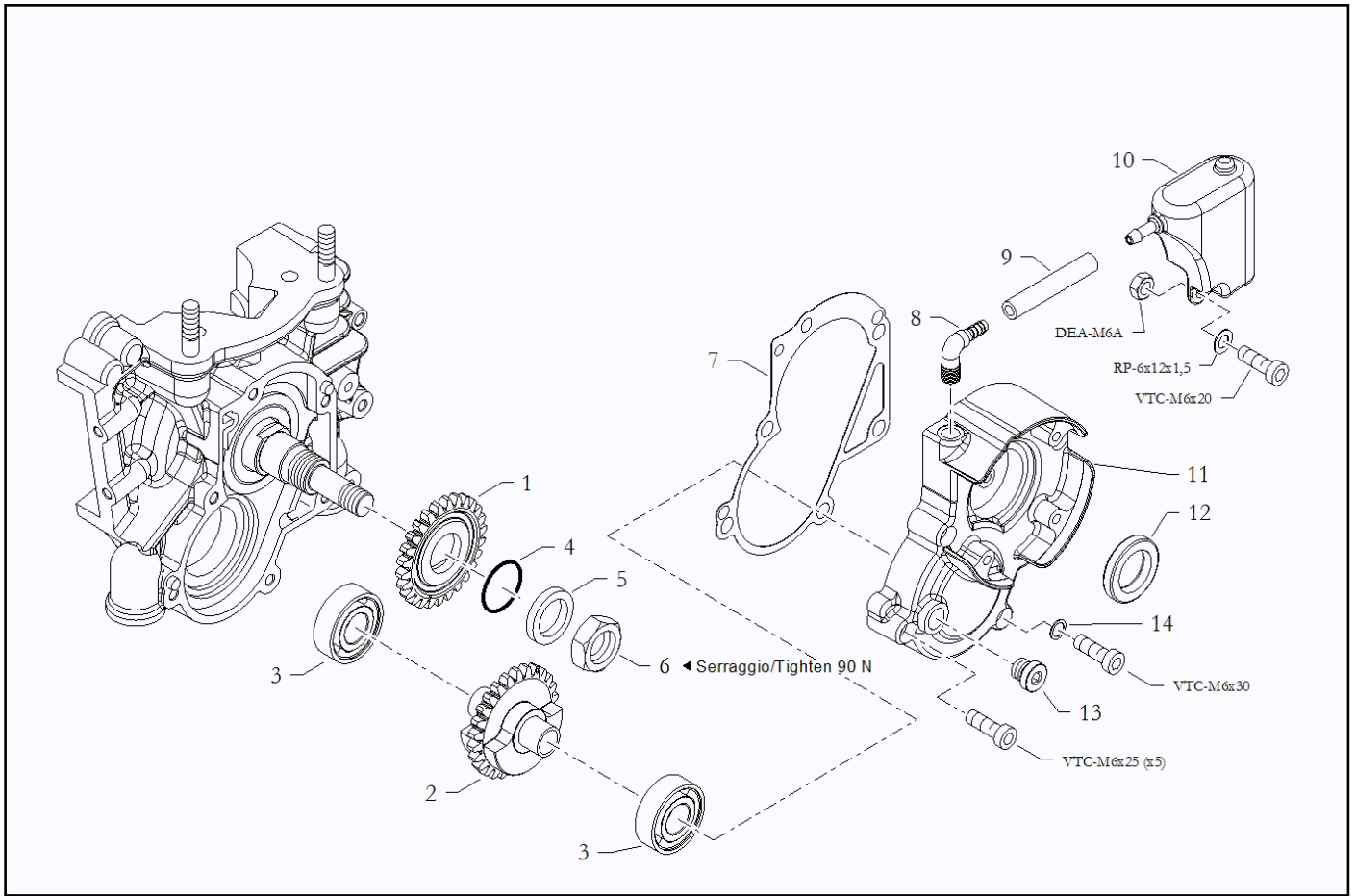

Pos	Code	Description
1	20.9290.06	BALANCED GEAR SHAFT
2	20.9289.06	COUNTERSHAFT
3	40.9304.00	BEARING 6202 TN1 15x35x11 C4
4	40.11089.00	GROMMET OR 20x1,5 NBR
5	20.9497.06	STOP GEAR WASHER
6	20.9445.06	NUT GEAR COUNTERSHAFT
7	20.9276.22	GASKET CRANKCASE COUNTERSHAFT
8	40.9245.00	CONNECTOR VACUUM
9	20.9444.20	OIL BREATHER PIPE L=59.5
10	20.9244.18	OVER FLOW BOTTLE ENGINE
11	20.8933.10	CRANKCASE COUNTERSHAFT
12	40.7936.00	OIL SEAL 26x35x7
13	40.4270.00	CYLINDRICAL CAP
14	40.8500.00	COPPER WASHER 6X10X1,5

06 - REED VALVE

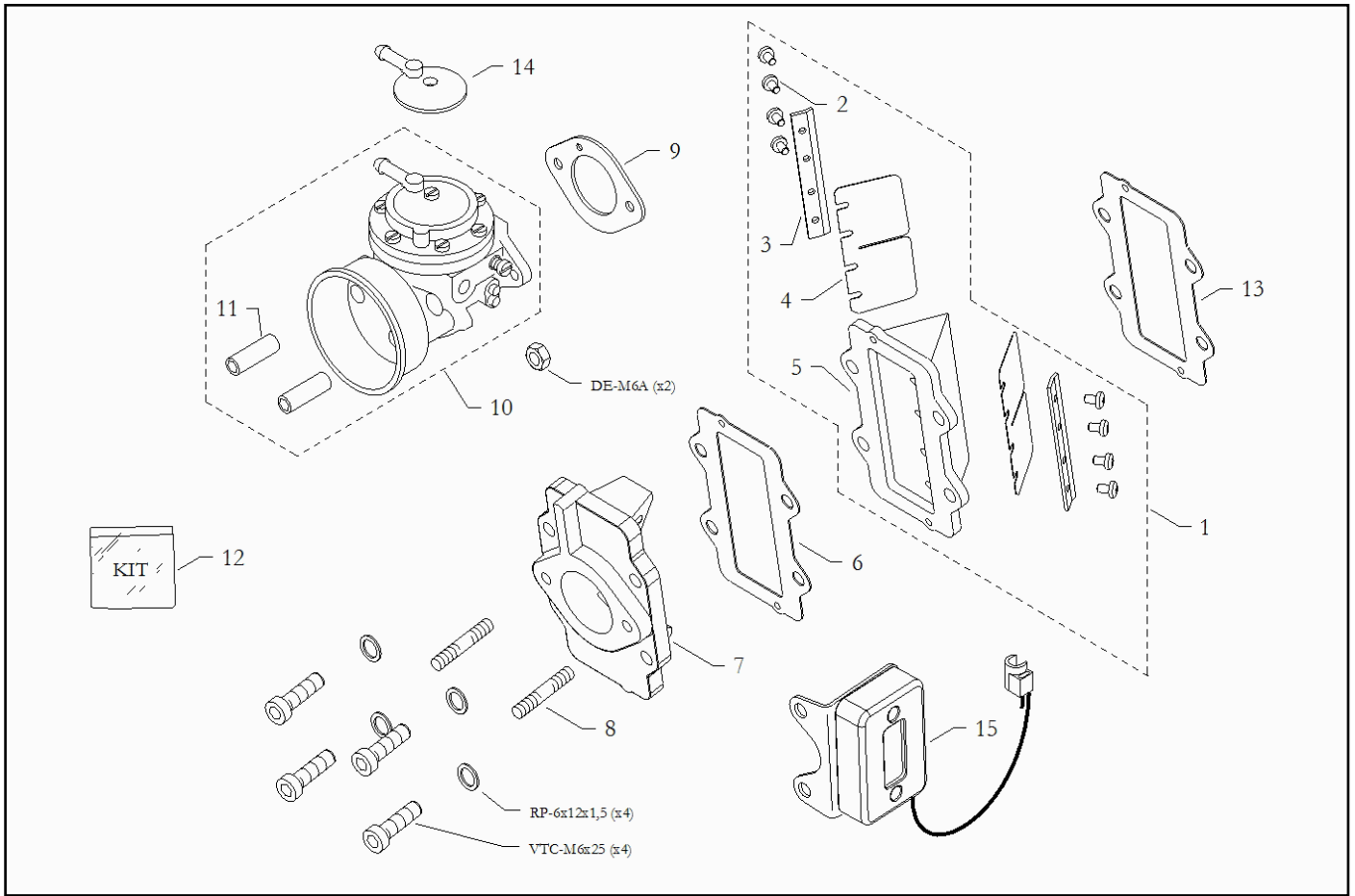

Pos	Code	Description
1	10.9653.00	REED VALVE
2	40.9652.00	REEDS SCREW
3	40.9651.00	REEDS CLIP
4	40.13783.00	PAIR REED PETALS CARBON IM
6	20.9239.22	REED VALVE BARE GASKET
7	40.9456.00	CONVEYOR CARBURETOR
8	20.11076.06	SCREW M6x28
9	20.9242.22	CARBURETOR GASKET
10	HW-44A	TILLOTSON 24MM CARBURETOR
11	20.10147.06	STUD M6
12	10.10183.00	OVERHAUL CARBURETTOR TRYTON HB-27 KIT
13	20.10402.22	REED VALVE GASKET
14		CARBURETOR PLASTIC TOP
15	10.11587.00	HOUR-METER ASSY.

07 - CLUTCH

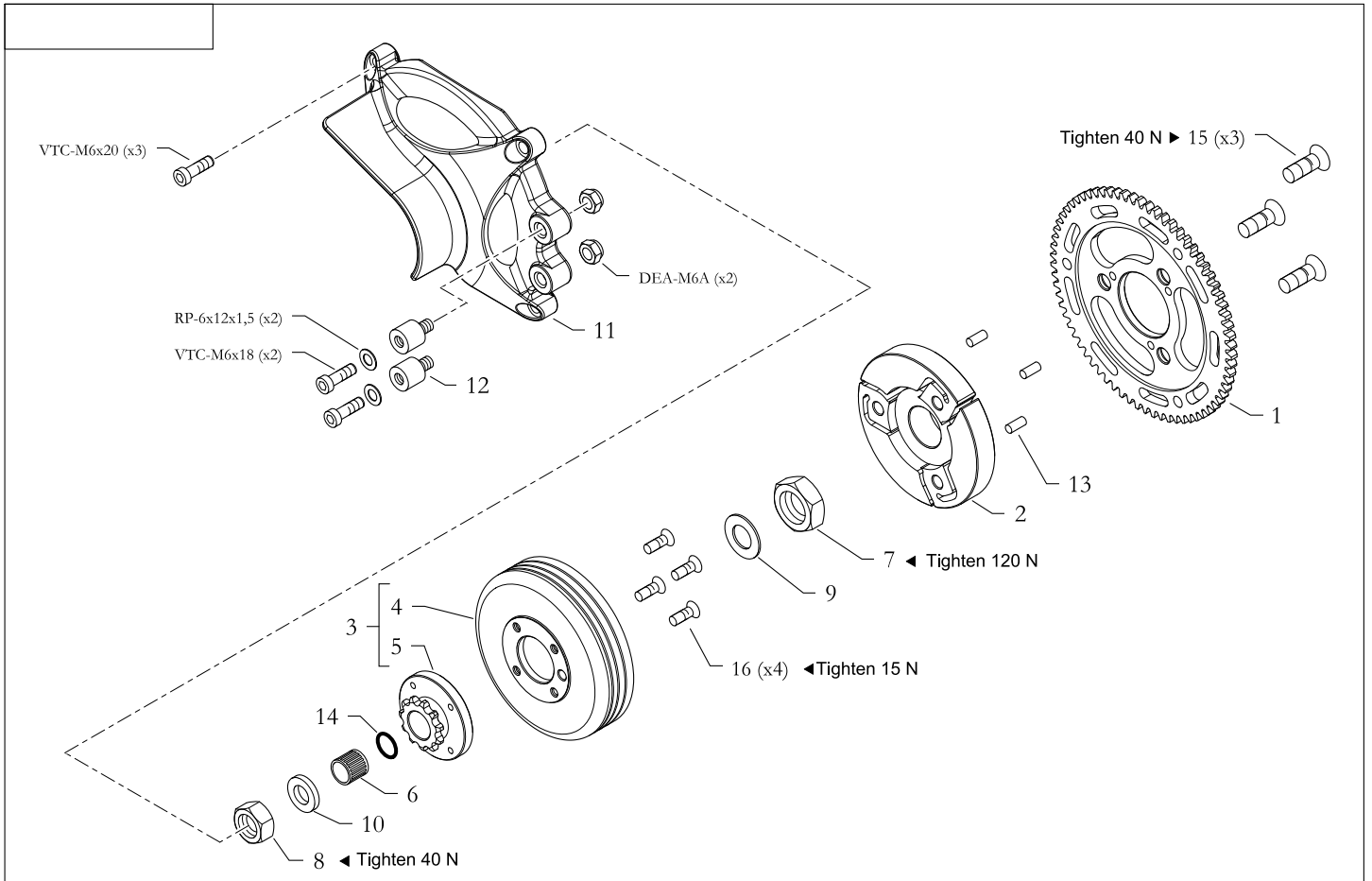

Pos	Code	Description
1	20.10186.06-BR	STARTER DRIVER WHEEL Z-70
2	20.9447.06	CLUTCH
3	10.9450.00	CLUTCH BELL Z11, ASSY
4	20.9336.06-BR	CLUTCH BELL
5	20.9346.06	SPROCKET Z10
5	20.9449.06	SPROCKET Z11
5	2010001.00	SPROCKET Z12
5	20.10002.06	SPROCKET Z13
6	40.10620.00	ROLLER CAGE 12x15x15
7	20.9448.06	CLUTCH NUT M20x1
8	40.11153.00	NUT M10X1
9	20.9380.06	WASHER 12x20x1.7
10	20.9379.06	SPROCKET WASHER 10x17x4
11	20.9262.18-RO	CLUTCH COVER
12	40.8033.00	ANTI-VIBRATION DAMPER 15x15 M6MF
13	40.10495.00	CYLINDRICAL PIN 4x10 DIN 6325
14	40.10636.00	GROMMET OR 114 D.I. 11,11x1,78 VITON ROSSO
15	40.11172.00	SCREW COUNTERSUNK FLAT M8X16 TORX
16	40.11174.00	SCREW COUNTERSUNK FLAT M5X8 TORX

08 - ENGINE STARTER

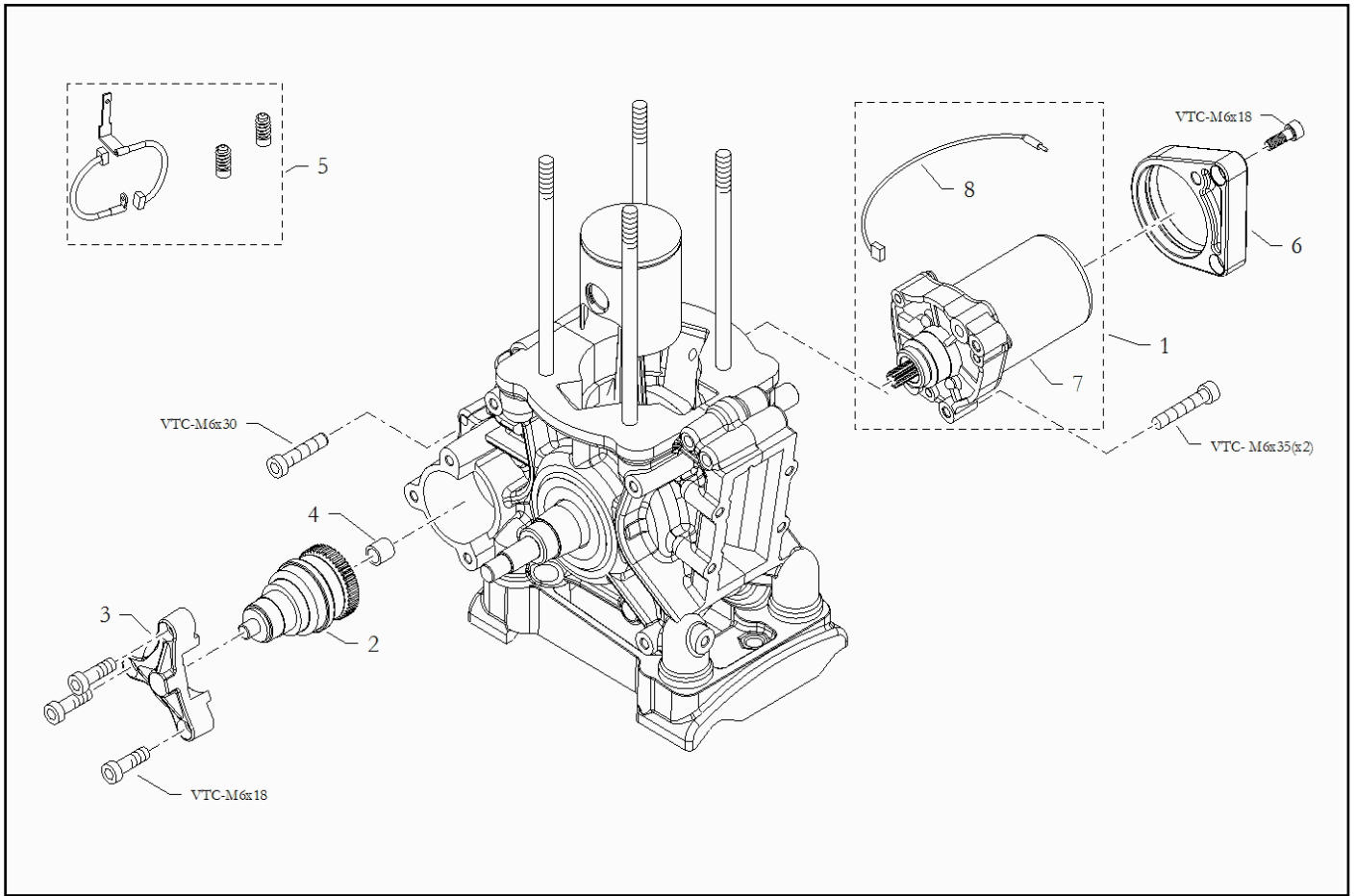

Pos	Code	Description
1	10.11564.00	ENGINE STARTER
2	40.9464.00	BENDIX
3	20.9175.18-GR	BENDIX COVER
4	40.9382.00	BEARING 8x10x12
5	10.10010.00	KIT OF BRUSHES FOR STARTER
6	20.8934.18-GR	SUPPORT CLAMP ENGINE STARTER
8	10.11444.00	BRUSH WIRED REINFORCED

09 - IGNITION

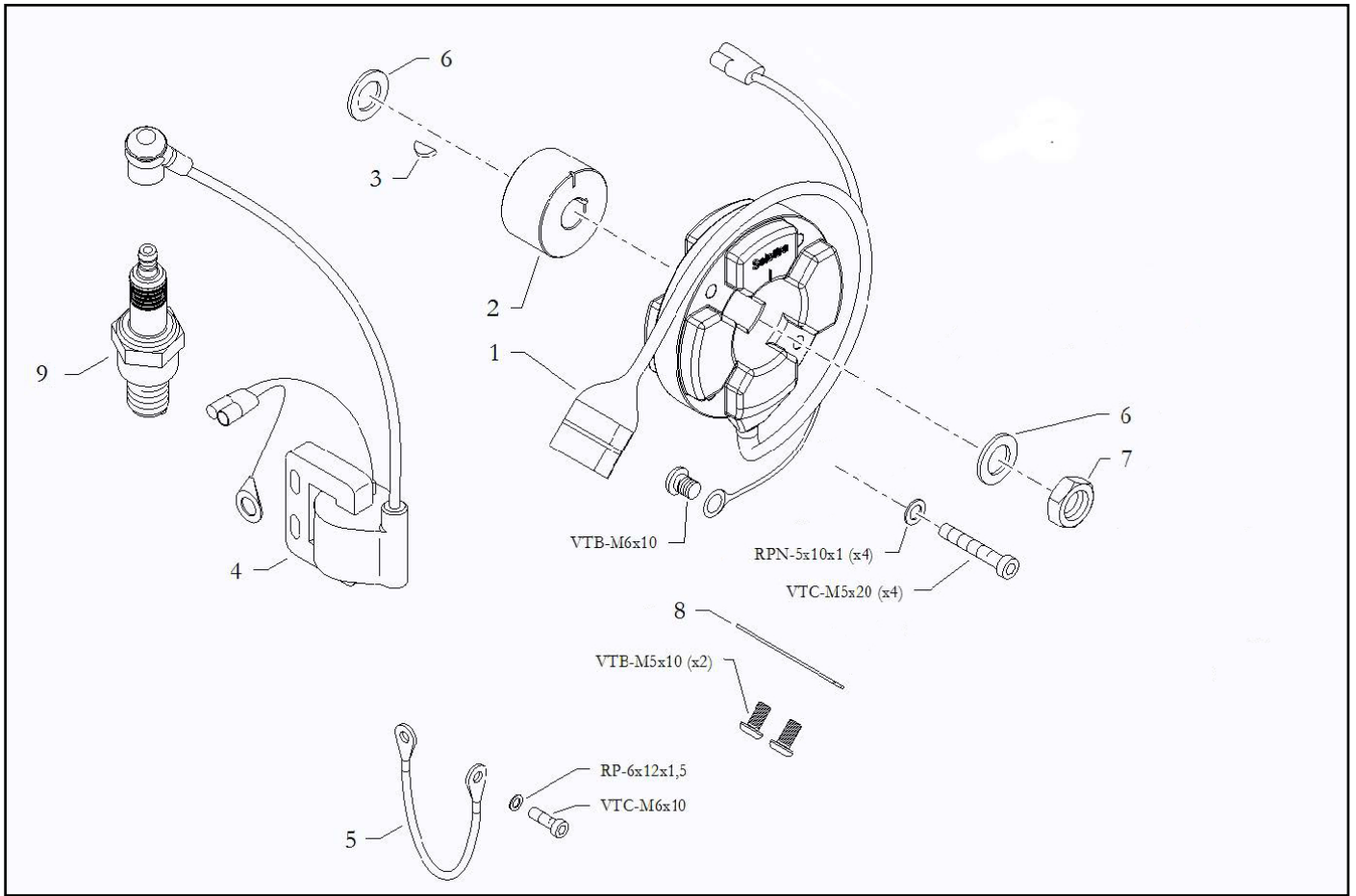

Pos	Code	Description
1	10.13687.00	STATOR DIG.S ROTOR AND STATOR
2	40.7893.00	ROTOR D.36x12 3P 68° LEFT
3	40.8067.00	WOODRUFF KEY 2.5x3.7 UNI-6606
4	40.13686.00	DIG.S IGNITION COIL AC
5	10.8711.00	GROUND CABLE
6	40.9042.00	WASHER 12x18x1
7	20.7833.06	IGNITION NUT M12x1 H6
8	20.9177.06	SUPPORT CONNECTOR IGNITION CARTER
9	10.11156.00	SPARK PLUG L8 S COLD
9	10.9884.00	SPARK PLUG L10S

10 - ELECTRONIC

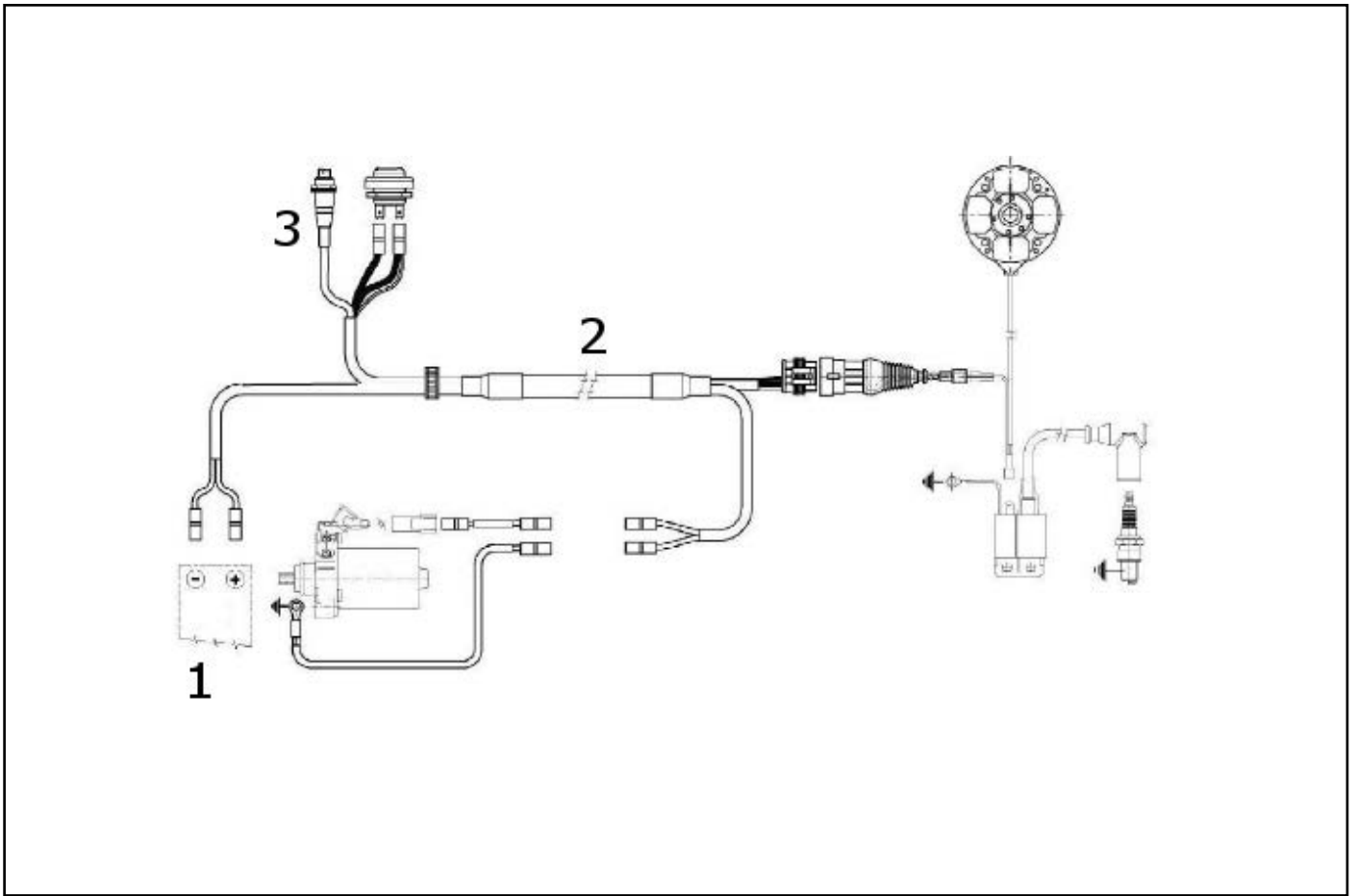

Pos	Code	Description
1	40.13676.00	BATTERY 12V
	10.13946.00	BATTERY SUPPORT
2	40.16390.00	MAIN WIRING
3	40.13691.00	START BUTTON KIT



12 - EXHAUST SILENCER

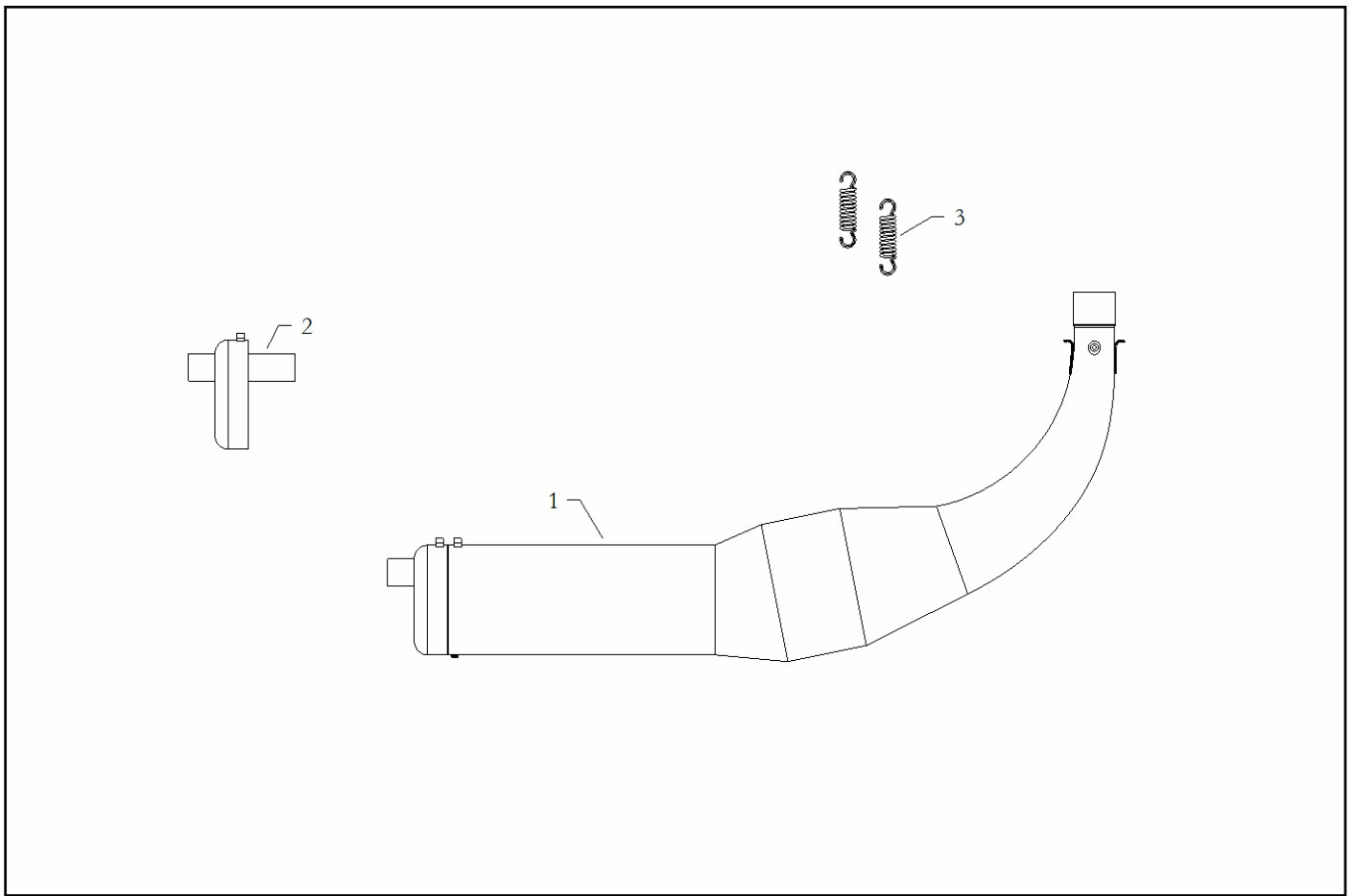

Pos Code	Description
1 10.10003.00	EXHAUST SILENCER
2 20.10006.06	SILENCER END
3 20.10768.06	EXHAUST SPRING L.45

13 - TOOLS

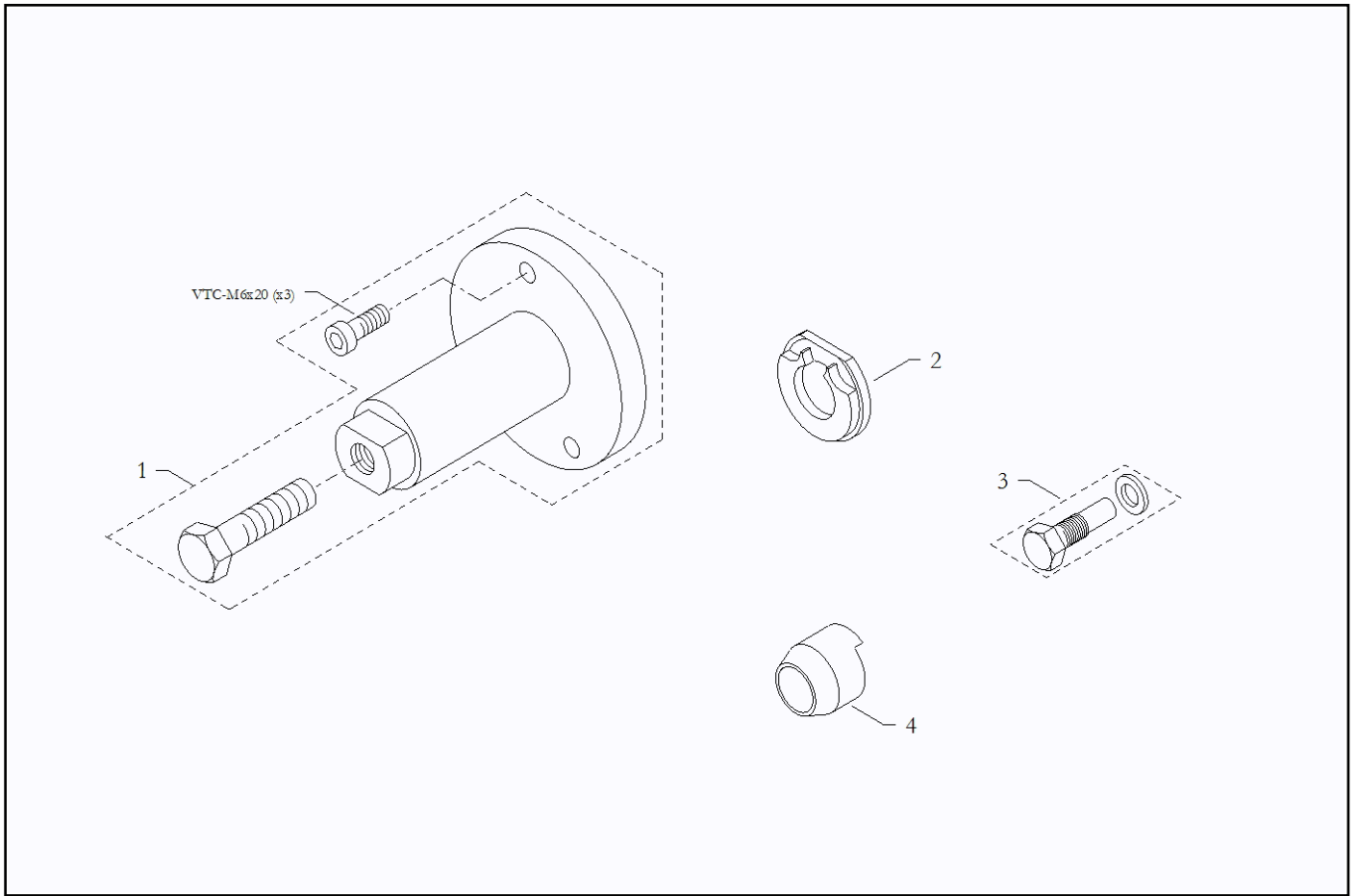

Pos	Code	Description
1	10.9681.00	CLUTCH PULLER
2	20.9782.06	STARTER DRIVER WHEEL PULLER
3	10.9784.00	COUNTERSHAFT PULLER
4	20.9785.06	BUSHING CRANKSHAFT OIL SEAL FITTING