

# **PondMAX<sup>®</sup>**

FOR GARDENS THAT GO THE EXTRA YARD

## **3 LED MULTI COLOUR POND & GARDEN LIGHT**

INSTRUCTION MANUAL



RF Remote Controller

DATE  
NOV 2021 v2.0

[www.pondmax.com.au](http://www.pondmax.com.au)  
**HOTLINE 1300 278 283**

MODEL  
**04PL682**

**WELCOME TO THE WORLD OF PONDMAX™.**  
 YOU MADE THE **RIGHT** CHOICE INVESTING IN THIS  
**QUALITY** PRODUCT. THANK YOU AND **ENJOY.**

**BEFORE USING THIS PRODUCT, PLEASE READ THESE INSTRUCTIONS CAREFULLY AND MAKE YOURSELF FULLY FAMILIAR WITH THE UNIT. PLEASE KEEP THESE INSTRUCTIONS IN A SAFE PLACE FOR FUTURE REFERENCE.**

### TECHNICAL SPECIFICATIONS

DESCRIPTION	3 LED MULTI COLOUR
VOLTAGE (V)	12
POWER (W)	5.8
CABLE LENGTH (m)	5
LUMENS	128

### DESIGN HIGHLIGHTS

Your PondMAX 3 LED Multi Colour Pond/Garden Light has been manufactured with advanced technology and quality materials to ideally integrate into any pond and garden scene, thanks to their compact design.

- The PondMAX light has a glass lens and is suitable for use in or out of water.
- The high power energy efficient LED emits a natural warm light providing years of maintenance free satisfaction.
- The easy to use RF Remote Control operates from up to 10m from the RF Control Module.
- The 240V transformer (not included) converts the power supply to a safe 12 volts for peace of mind in your pond or garden. (Recommended Transformer: 04ST032 - 12VA 1000mA - single light only)

### INSTALLATION

If required, have a qualified electrician install a weather proof power point near to the pond or garden, within reach of the transformer, RF Control Module and light.

- Mount the transformer and RF Control Module in a dry and protected location making sure that they can't be wet by either rain or reticulation. NB: The distance between the transformer and RF Control Module is governed by the length of the RF Module Cable (7).
- For pond installation slide the weighted base into the circular recess on the underside of the light body. Position the light in the desired location taking care not to wet the 4 pin female plug at the end of the cable.
- For garden installation slide the garden spike into the circular recess on the underside of the light body. Holding the light body firmly, push the light with attached spike into the desired location taking care not to penetrate any hidden services.
- Adjust the light until facing in the general direction of the feature you wish to illuminate. We recommend final adjustments be carried out at night. For single light installations plug the 4 pin female plug on the end of the light

cable into the 4 pin male connection of the RF Control Module (5) and tighten locking collar firmly. Now plug the RF Module Cable (7) into the RF Control Module (5) and then the free end into the transformer, tightening both locking collars firmly. The transformer can now be turned on.

- Insert the battery supplied into the RF Remote Control (8) and turn on. The RF Remote Control is easy to use and self-explanatory.
- A number of lighting effects can be achieved with the various modes.
- Once in the correct position lock the light by tightening the thumb screws, taking care not to over tighten.

- Multiple lights can be connected together to the same transformer using the 4 Pin Male Connection (4) on the side of the light body. A larger transformer is required (04ST072 - 72VA for up to 6 lights).
- A maximum of 6 lights can be connected in a single chain (a larger transformer is required), see table below.
- There is minimal maintenance required with PondMAX pond lights. The light should be inspected on a regular basis to ensure the light or cable is not damaged in any way. Clean the lens on the light regularly for maximum efficiency.

EXPANDABLE LIGHTING SYSTEM	TRANSFORMER REQUIRED	PRODUCT CODE
1 LIGHT	20VA	04ST016
3 LIGHTS	50VA	04ST018
6 LIGHTS	72VA	04ST072

### EXPLODED VIEW

- Light Body
- Weighted Base
- Garden Spike
- 4 Pin Piggyback Connection\*
- Transformer Adaptor
- Screw Cap
- RF Module Cable
- RF Remote Control
- Thumb Screw
- For additional lights

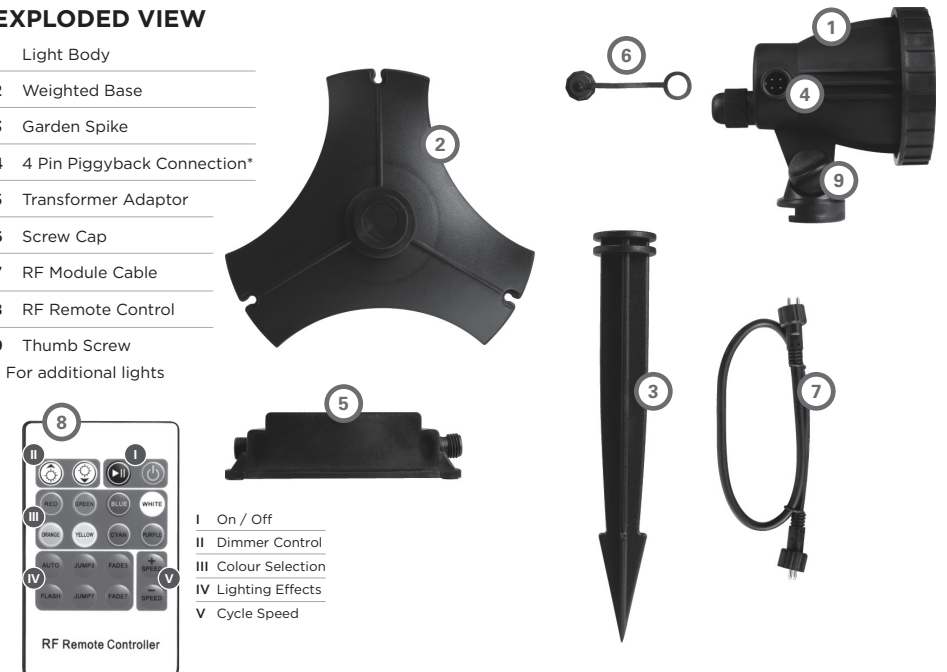

- I On / Off
- II Dimmer Control
- III Colour Selection
- IV Lighting Effects
- V Cycle Speed

## IMPORTANT SAFEGUARDS

- The light should only be used in clean water. Do not use the light in any solvent or flammable liquids. Do not use in chlorinated or salt water.
- Do not operate the light if the light or any of the components of the light such as the power cable or transformer have been damaged.
- If the 240V plug supplying the transformer gets wet, do not unplug the cord. Disconnect the circuit breaker that supplies power to the power outlet. Then unplug and examine the plug and power outlet for presence of water. If the power outlet has become wet, you should consult an electrician before using the again.
- Always use a properly grounded power supply that is connected to an RCD with a rated residual operating current not exceeding 30mA as per AS/NZS8350.2.41:1997.
- Always unplug the light from the power supply when not in use or before performing any maintenance.
- Never pull the transformer cord to disconnect the plug from the power supply. Grasp the plug and pull to disconnect.
- Do not install or store the light where it will be exposed to extreme hot or cold temperatures.
- Keep out of reach of children or pets. This appliance should not be used by children or interim persons without supervision.
- Do not cut the cord as this will result in voiding your warranty. Care should be taken to arrange the power cord so that it cannot be accidentally tripped over or pulled.
- Do not attempt to repair the light yourself. Return to an authorised service centre or place of purchase if a fault occurs.
- Do not use in water above 35°C.

## LIMITED WARRANTY

- To guard against injury, basic safety precautions should be observed including but not limited to the following;
- This product comes with a warranty against defects (Warranty). The benefits provided in this Warranty are in addition to other rights and remedies available to you under the Australia Consumer Law. The Warranty is provided to the original purchaser of the product on the following terms:
- The Warranty is given by Aquatec Equipment Pty Ltd trading as Aquatec Equipment, 37 Edison Circuit, ForrestdaleWA 6112. Contactable by phone 300 552 202 or email info@pondmax.com.au.
- To make a claim under the Warranty you must return the faulty product to the place of purchase with a valid receipt or proof of purchase.
- A Warranty claim must be made within 2 years of the date of purchase.
- If your claim complies with the above terms and the product is not an Exhaustible Item and no Voiding Events have occurred, we will (at our sole discretion):
  - repair the product, if possible; or
  - provide a replacement product; or
  - if a replacement product is not available, provide a refund for the purchase price paid.
- You will bear the cost associated with claiming under the Warranty such as the cost of transportation and delivery of the product to and from the place of purchase.
- The Warranty will be void if any of the following events occur, as determined by us, at our sole discretion (Voiding Events):
  - any tampering/removal of warranty/identification labels or electrical components is evident;
  - the defect has arisen due to: an accident, incorrect or inadequate installation, misuse or abuse of the product (including improper maintenance and service), excessive wear and tear, not following manufacturer's guidelines instructions, or the product has been used in a manner contrary to the purpose of suitability of the product;
  - the product has been modified without our authority;
  - the defect is caused by power surges/spikes brownouts.
- Loss of livestock, damage of property or personal injury caused by the improper use or abuse of the product will not be covered and the manufacturer excludes all liability for such events, of the extent permitted by law.
- In addition to the Warranty set out above, our goods come with guarantees that cannot be excluded under the Australian Consumer Law. You are entitled to a replacement or refund for a major failure and for compensation for any other reasonably foreseeable loss or damage. You are also entitled to have the goods repaired or replaced if the goods fail to be of acceptable quality and the failure does not amount to a major failure.

**NOTE: Parts and features differ from model to model. All images used are for illustrative purposes only. Not all features depicted apply to all models in the range and these are subject to change.**



### IMPORTANT

These accessories and attachments are recommended for use with your PondMAX product specified in this manual. The use of any other accessories or attachments might present a risk of injury to persons. Only use the accessory or attachment for its stated purpose.

Please consult your retailer for quality original PondMAX replacement parts.

Visit [www.pondmax.com.au](http://www.pondmax.com.au) for your nearest stockists.

E.&O.E.