

# ■ Infrared Fixture Integrated Sensor For High Bay Light LOD-BRI819P-B-O Instruction

# ■ Infrared Fixture Integrated Sensor For High Bay Light LOD-BRI819P-B-O Instruction

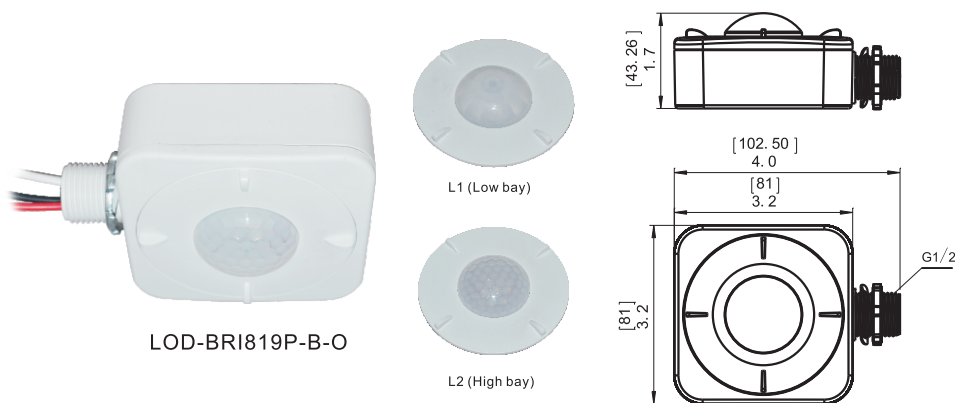

LOD-BRI819P-B-O

L1 (Low bay)

L2 (High bay)

## INTRODUCTION

The product is a new Energy-saving switch, it adopts good sensitivity detector, integrated circuit and SMT. It gathers automatism, convenient safe, Energy-saving and practical functions. It utilizes the infrared energy from human as control-signal source, it can start the load at once when one enters detection field. It is easy to install and used widely, possessing the function of power show and detection show.

## SPECIFICATIONS

Power supply	120/277VAC 50/60Hz
Maximum load @ -40°F ~ +167°F (-40°C ~ +75°C)	Resistive/Tungsten - 600W@120V Electronic Ballast - 800W@120V/1200W@277V
PIR Len L1	30ft@25ft height/360
PIR Len L2	30ft@40ft height/360
Time setting	10sec. -30min.(adjustable)
Light-control	10-300Lux(adjustable)
Humidity	Max. 95% RH
Temperature	-40°F ~ +167°F (-40°C ~ +75°C)

## ⚠ WARNING

**NOTE:** Warm up time is 40seconds. After the sensor connects input power first time, the light will keep on 40seconds, then go off to work normally.

**NOTE:** Factory Default Setting: 100% sensitivity, Hold on time: 10seconds, daylight sensor is disable.

**NOTE:** Any setting changed by DIP Switch, the led light that sensor connect will on/off as confirm.

## SENSOR INFORMATION

### L1 Len

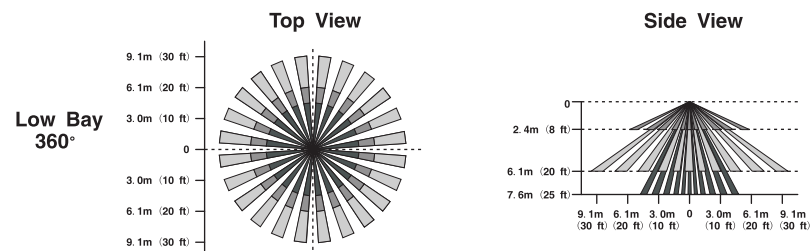

### L2 Len

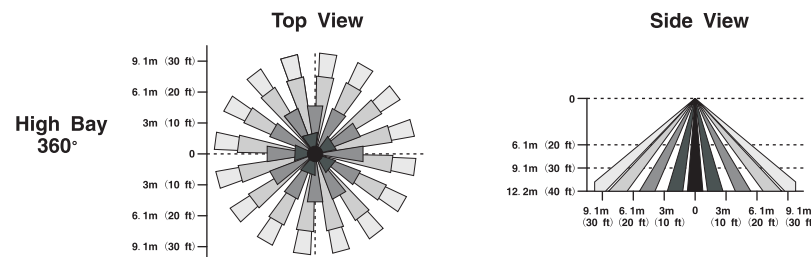

## LOD-BRI819P-B-O MOUNTED TO LINEAR HIGH BAY LIGHT

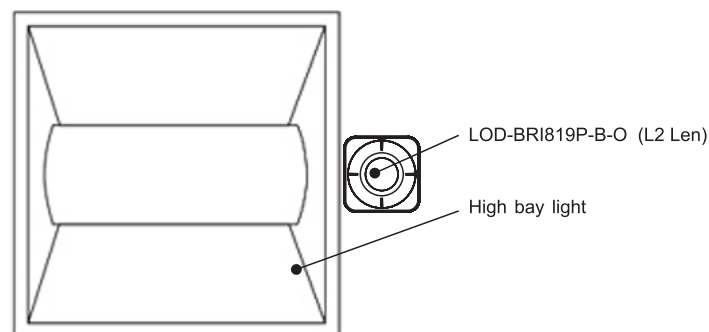

LOD-BRI819P-B-O (L2 Len)

High bay light

# Infrared Fixture Integrated Sensor For High Bay Light LOD-BRI819P-B-O Instruction

## PARAMETER SETTING BY DIP SWITCH

Shown as chart below : By setting the 1, 2, 3 to set the detection range of products , by setting 4, 5, 6, 7 to set the delay time of products, by setting the 8, 9, 10 to set the light-control of products.

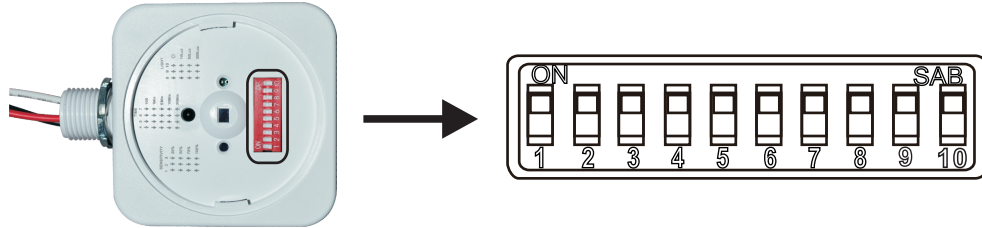

## Detection Range Setting (sensitivity)

Detection range is the term used to describe the radius of the more or less circular detection zone produced on the ground after mounting the sensor light at a height of 40ft, pull switch to the ON position as "↑", pull switch to the OFF position as "↓", switch location and detection range of the corresponding table is as follows:

		SENSITIVITY			
		1	2	3	
ON	↑	↓	↓	↓	20%
		↓	↑	↑	50%
OFF	↓	↑	↓	↑	75%
		↑	↑	↑	100%

SENSITIVITY: 1, 2, 3

## Hold Time Setting

The light can be set to stay ON for any period of time between approx. 10sec and a maximum of 30min. Any movement detected before this time elapse will re-start the timer. It is recommended to select the shortest time for adjusting the detection zone and for performing the walk test. Pull switch to the ON position as "↑", pull switch to the OFF position as "↓", switch location and detection range of the corresponding table is as follows:

		TIME			
		4	5	6	7
ON	↑	↓	↓	↓	↓
		↓	↓	↓	↑
		↓	↑	↓	↓
		↓	↑	↓	↑
OFF	↓	↑	↓	↓	↑
		↑	↓	↓	↑

TIME: 4, 5, 6, 7

# Infrared Fixture Integrated Sensor For High Bay Light LOD-BRI819P-B-O Instruction

## Light-control Setting

The chosen light response threshold can be infinitely from approx. 10-300lux, pull switch to the ON position as "↑", pull switch to the OFF position as "↓", switch location and light-control of the corresponding table is as follows:

		LIGHT			
		8	9	10	
ON	↑	↓	↓	↓	☀ (light sensor disable)
		↓	↓	↑	10Lux
OFF	↓	↓	↑	↑	50Lux
		↑	↑	↓	300Lux

LUX: 8, 9, 10

## WIRING DIAGRAMS

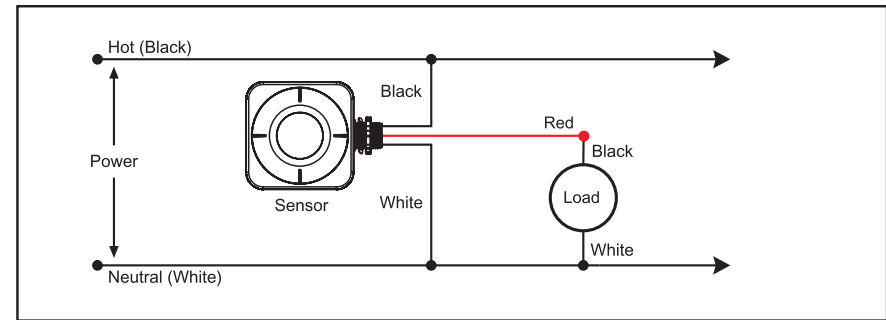

## SOME PROBLEMS AND SOLUTIONS

- The load doesn't work:
  - a. Check that the power and load requirements are correct.
  - b. Check if the load is good.
  - c. Check if the show lamp accelerates its speed after detecting.
  - d. Check if the working light corresponds to the ambient light.
- The sensitivity is poor:
  - a. Check if there is obstruction in front of the detection window to effect receiving the signals.
  - b. Check if the ambient temperature is too high.
  - c. Check if the signal source is in the detection fields.
  - d. Check if the installation height corresponds to the height indicated in this manual.
  - e. Check placement of sensor in relation to movement flow.
- The sensor can't shut the load automatically:
  - a. Check if there are continual signals in the detection fields.
  - b. Check if the time delay is set to the longest.
  - c. Check if the power corresponds to the instruction.
  - d. Check if there is temperature change near the sensor.

