

LED LOC-2FTSL-347-22W Multi CCT Strip Light

FEATURES

- Default CCT: 5,000K
- IP20 rated
- V-Hook included
- DC 12V auxiliary
- 50,000 hours lifetime



SUITABLE APPLICATIONS

- Parking Lot
- Supermarket
- Corridor
- Retail Spaces
- Warehouses

CONSTRUCTION:

22-gauge metal housing with matte white paint. PMMA cover lens. Frosted lens.

OPTICAL SYSTEM:

Seoul 2835 LED chips. High quality tempered glass optics. 120° beam angle.

WARRANTY:

5-year limited warranty. Actual performance may differ as a result of end-user environment and application.

ELECTRICAL:

Available as 120-347V input. -20°C to 50°C, -4°F to 122°F

INSTALLATION & MOUNTING:

Suspension or surface mount option.

CONTROLS & DIMMING:

0-10V dimming comes standard.



MODEL NUMBER – 3,500K 4,000K 5,000K	WATTAGE	LUMENS	EFFICACY	CRI	POWER FACTOR	THD	REPLACES
LOC-2FTSL-347-22WMCCT(35/40/50)DF	22W	2,877.6LM	128.88LM/W	84.3	0.9358	13.07%	100W

Series	Size	Voltage	Wattage	Color Temperature	Dimming
LOC-SL	2FT = 2 foot	120-347V	22W	3500K 4000K 5000K	Dimmable

MEASUREMENTS

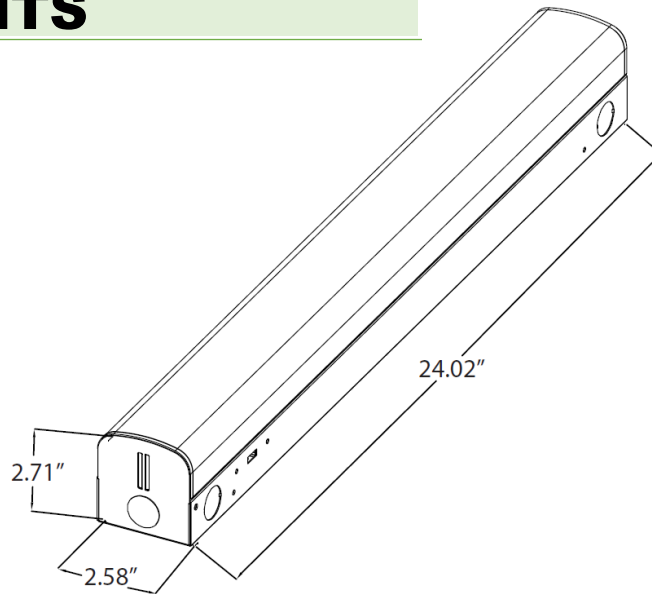

MODEL	QUANTITY	WEIGHT	UPC CODE
LOC-2FTSL-347-22WMCCT(35/40/50)DF	1	lbs	00810050940535

OPTIONAL ACCESSORIES

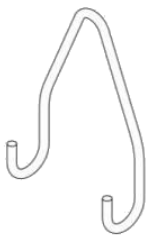

V-Hook (included)



Aircraft Cable



HB001 VCR 1



Remote Control
LOC-GDHB-HD05R



Emergency Back-up

3,500K

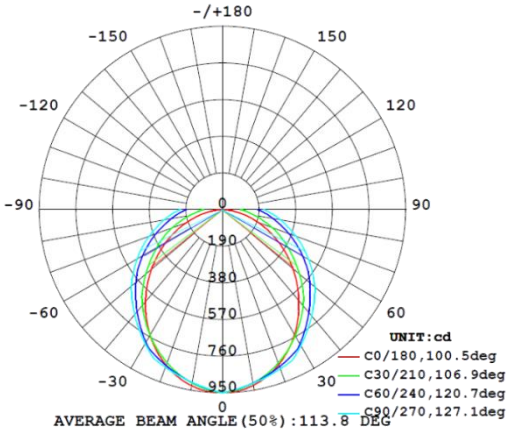

4,000K

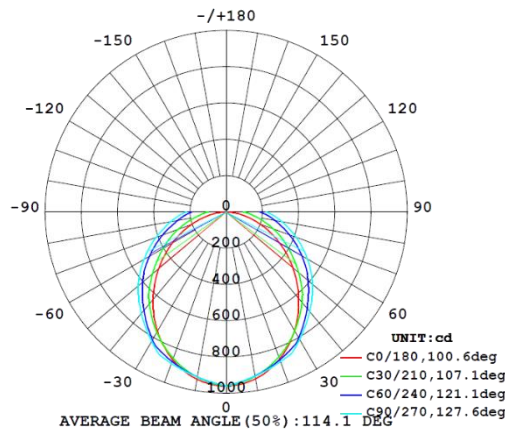

5,000K

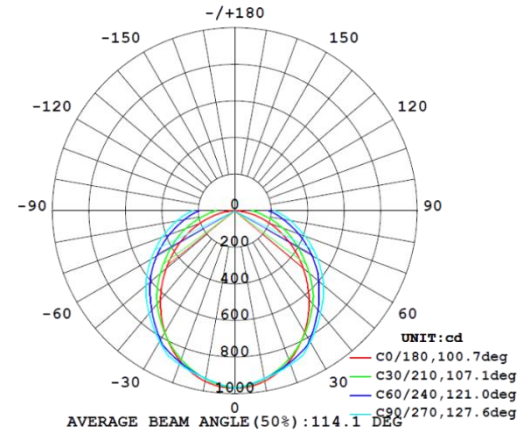

3,500K

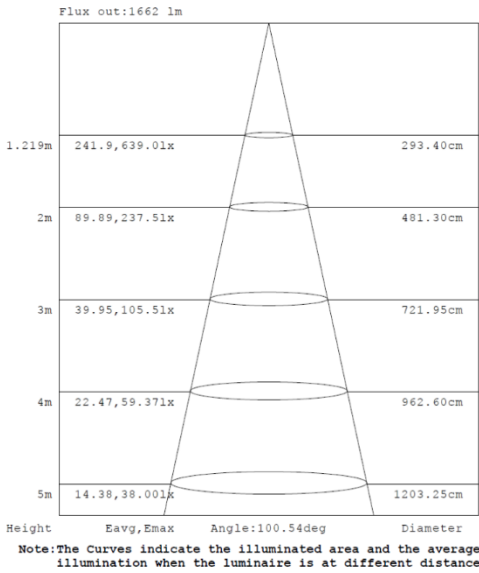

4,000K

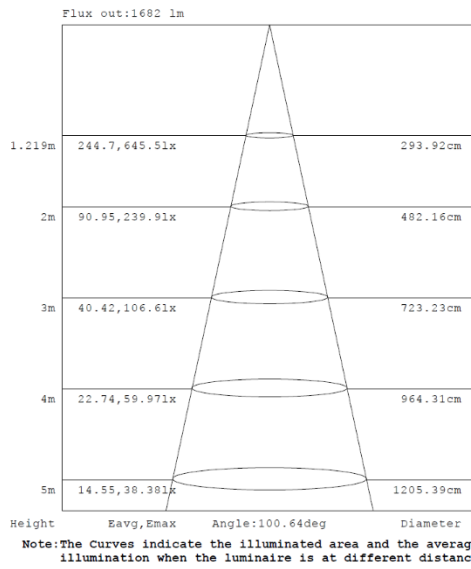

5,000K

