

Parts:

⚓ x16

○ x16

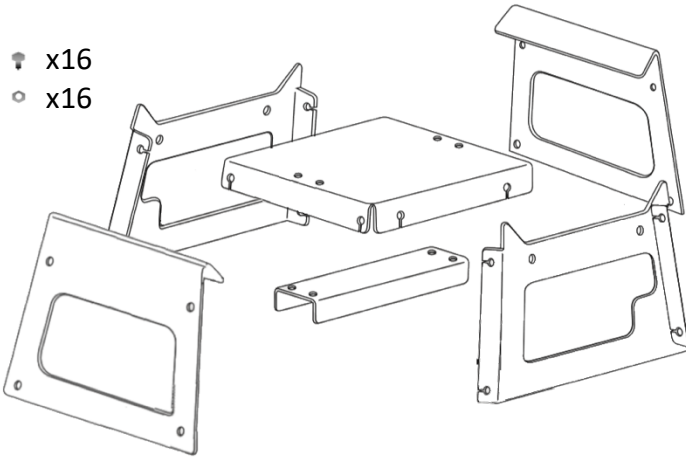

1.

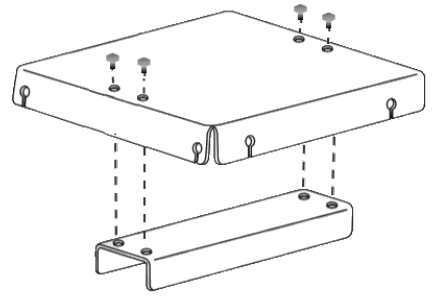

2.

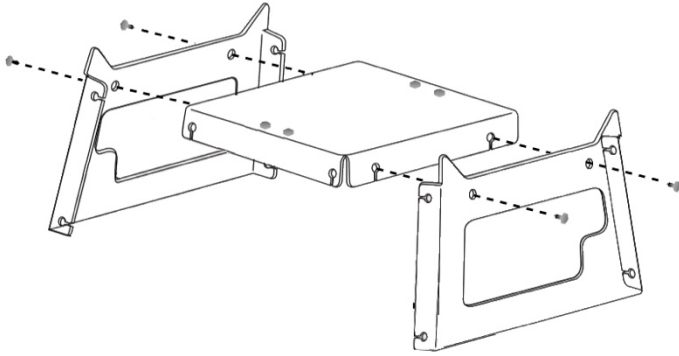

2a.

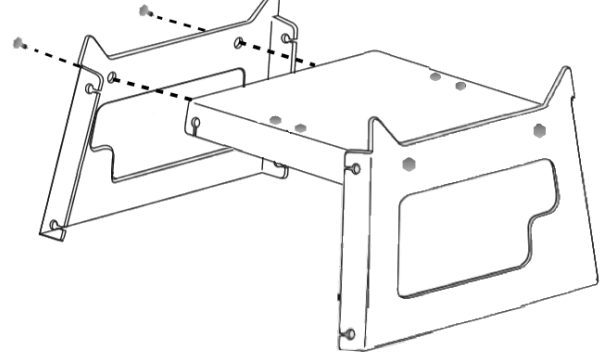

2b.

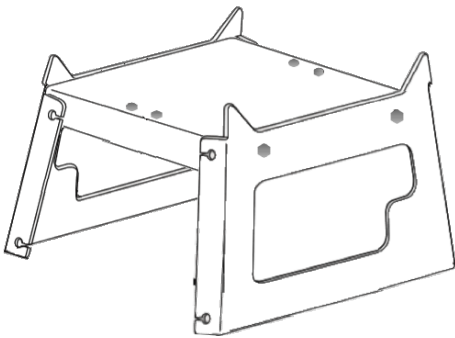

3.

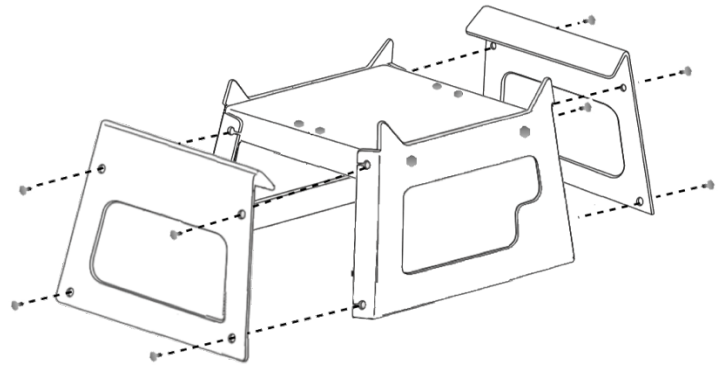

4.

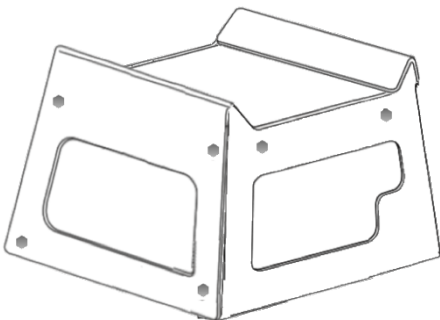

1* Insert bolts and tighten
(these are the only four bolts to be tightened during assembly)

2* Insert bolts, wind on by hand only.

3* Insert bolts, wind on by hand only.

4* Tighten bolts - Step 2

5* Tighten bolts - Step 3