

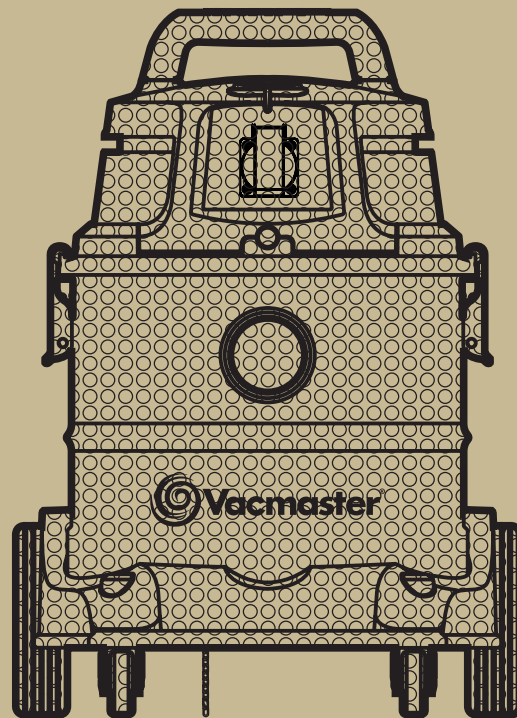

**GB** VK1520SIWC 950203 WET AND DRY VACUUM CLEANER



*WET & DRY*  
**VACUUM CLEANER**

**1500W / 20L / VK1520SIWC 950203**



# T ABLE OF CONTENTS

SECTION	PAGE
Warranty	3
Safety Instructions and Warnings	3
Specifications	4
Unpacking and Checking Carton Contents	4
General Assembly Instructions	5
Switching On/Off	6
Dry Vacuum Operation	6
Wet Vacuum Operation	7
Maintenance	8
Installing & Cleaning Cartridge Filter	8
Installing & Cleaning Foam Sleeve Filter	8
Installing & Cleaning HEPA Filter	9
Troubleshooting	9
Exploded View and Parts List	10

**Thank you for purchasing this Vacmaster® wet/dry vacuum cleaner. Feel confident that with Vacmaster® you are obtaining a high quality product engineered for optimal performance. This vacuum is capable of picking up liquids and dry materials.**

**FOR YOUR SAFETY CAREFULLY READ AND UNDERSTAND ALL INSTRUCTIONS.**

## **WARRANTY**

Vacmaster® takes pride in producing a high quality, durable product. This Vacmaster® product carries a limited two (2) year warranty against defects in workmanship and materials from date of purchase under normal household use. Warranty does not apply to defects due to direct or indirect abuse, negligence, misuse, accidents, repairs or alterations and lack of maintenance. Please keep you receipt as proof of purchase.

## **SAFETY INSTRUCTIONS & WARNINGS**

### **IMPORTANT SAFETY INSTRUCTIONS**

Read and understand all instructions before using this vacuum.

Read and understand this owner's manual and all labels on the Wet/Dry Vacuum cleaner before operating. Safety is a combination of common sense, staying alert and knowing how your vacuum works. Use this Wet/Dry Vac only as described in this manual.

Household Type

### **SAVE THIS MANUAL FOR FUTURE REFERENCE.**

When using an electrical appliance, basic precautions should always be followed including the following :

**WARNING:** TO REDUCE THE RISK OF FIRE, ELECTRIC SHOCK OR INJURY:

- Do not run vac unattended.
- Do not vacuum, or use this Wet/Dry Vac near flammable liquids, gases, or explosive vapors like gasoline or other fuels, lighter fluids, cleaners, oil-based paints, natural gas, hydrogen, or explosive dusts like coal dust, magnesium dust, grain dust, or gun power. Sparks inside the motor can ignite flammable vapors or dust.
- Do not vacuum anything that is burning or smoking, such as cigarettes, matches, or hot ashes.
- Keep cord away from heated surfaces.
- Do not expose to rain. Store indoors.
- Do not unplug by pulling on cord. To unplug, grasp the plug, not the cord.
- Do not use with damaged cord, plug or other parts.

- If your Wet/Dry Vac is not working as it should, has missing parts, has been dropped or damaged, left outdoors or dropped into water, return it to an independent service center.
- Do not pull or carry by cord, use cord as handle, close a door on cord, or pull cord around sharp edges or corners.
- Do not run Wet/Dry Vac over cord.
- Do not handle plug or the Wet/Dry Vac with wet hands.
- To reduce the risk of health hazards from vapors or dusts, do not vacuum toxic materials.
- Do not use or store near hazardous materials.
- Do not use this Wet/Dry Vac with a torn filter or without the filter installed except when vacuuming liquids as described in the operation section of this manual.
- Do not allow to be used as a toy. Close attention is necessary when used by or near children.
- To reduce the risk of injury from accidental starting, unplug power cord before changing or cleaning filter.
- Do not leave Wet/Dry Vac unattended when plugged in. Unplug from outlet when not in use and before servicing.
- Turn off Wet/Dry Vac before unplugging.
- Do not put any object into ventilation openings. Do not vacuum with any ventilation openings blocked; keep free of dust, lint, hair or anything that may reduce air flow.
- Keep hair, loose clothing, fingers, and all parts of body away from openings and moving parts.
- To reduce the risk of falls, use extra care when cleaning on stairs.
- If the supply cord is damaged, it must be replaced by a special assembly available from the manufacturer or its service agent.
- This appliance is not intended for use by persons (including children) with reduced physical, sensory or mental capabilities, or lack of experience and knowledge, unless they have been given supervision or instruction concerning use of the appliance by a person responsible for their safety.
- Children should be supervised to ensure that they do not play with the appliance.

**FOR ADDITIONAL PROTECTION: It is recommended that this vac be used in conjunction with a residual current device (RCD) with a rated residual current of 30mA or less.**

### **Special Safety Information**

- Never vacuum up hot ashes or pointed or sharp objects.
- Never use the appliance in damp rooms.

- Don't use the appliance without a dust bag (an exception is wet vacuuming). Make sure that the dust bag is inserted into the appliance correctly.
- When using the appliance, make sure that no hair, clothing, or members are drawn in.
- Keep the vacuum cleaner away from heat sources such as radiant heaters, ovens, and so on.

### Disposal Information

The appliance contains electric and electronic components and may not be disposed of as household garbage. The local and currently applicable legislation must be observed unconditionally.

## SPECIFICATIONS

Motor:	230V-50Hz
Container:	20L
Watt:	1500W
Filter-Dry:	PET Cartridge Filter & Dust Bag
Filter-Wet:	Foam Sleeve Filter

## UNPACKING AND CHECKING CARTON CONTENTS

Remove entire contents of carton. Check each item against the carton contents list.

### Carton Contents List

Key	Description	QTY
A	Vac Assembly	1
B	Hose	1
C	PRE Cloth Filter	1
D	Crevice Car Nozzle	1
E	Floor Brush/Squeegee	1
F	Round Dust Brush	1
G	2 Coated Tube	2
H	PET Cartridge Filter	1
I	Filter Retainer	1
J	Collection Bag	1

K	Foam Sleeve Filter	1
L	Air Control Handle	1
M	Rear Wheels	2
N	Hub Caps	2
O	'R' Lock Pins	2
P	Washers	4
Q	Casters	2
R	Wheel Shaft	1
S	Operator's Manual	1

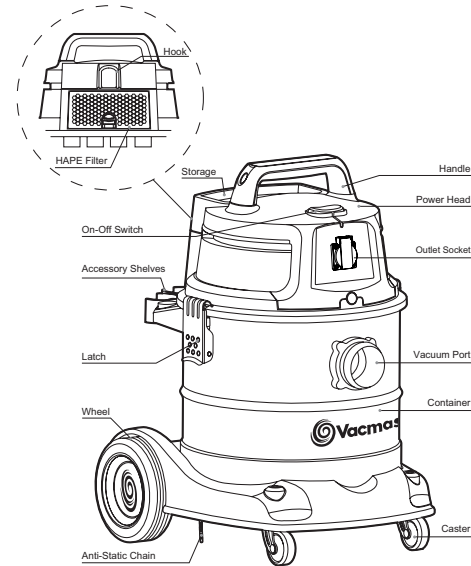

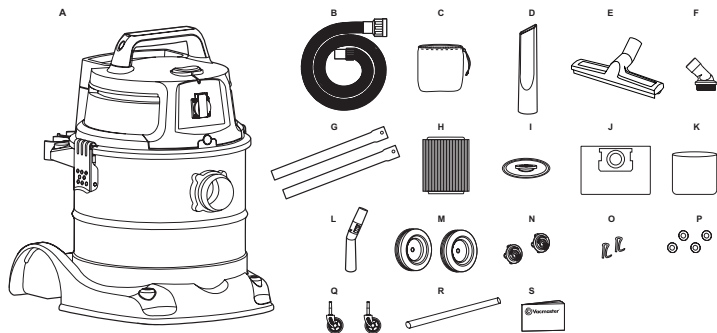

- installed. If cartridge filter is not installed, refer to page 8 for filter installation. (fig.8&fig.9)The PET cartridge filter fit for wet & dry vacuum cleaning.
8. Put the PRE cloth filter over the filter tray with the attached PET cartridge filter. (fig.10)
9. Optional, for improved dust filtering, fit collection bag flange onto the inlet stub, taking care not to damage the bag. (fig.11)
10. Place the power head back on the container, and secure into place using the 2 side latches. (fig.12&fig.13)
11. Store accessories on accessory storage frame or posts back of this vac. (fig.14)
12. Secure the large end of the hose into the vacuum port on the container and screw into place. (fig.15)
13. Choose the desired accessories and extension wands and push onto the suction tube. (fig.16)

## GENERAL ASSEMBLY INSTRUCTIONS

**WARNING: DO NOT PLUG IN POWER CORD TO POWER OUTLET, MAKE SURE PLUG IS DISCONNECTED BEFORE ASSEMBLING THE WET/DRY VACUUM.**

### UNPACKING YOUR WET/DRY VACUUM & GENERAL ASSEMBLY.

1. Verify that the power cord is disconnected from the outlet. (fig.1)
2. Undo the latches. (fig.2)
3. Lift the power head off the container. (fig.3)
4. Remove the contents from inside the container, make sure you have all contents as listed on page 12. (fig.4)
5. With the power head removed, turn the container upside down. Insert the two casters into the socket on to bottom of the castor feet. (fig.5)
6. Insert the rear wheel shaft (R) into the rear support block. Insert washer (P) on the shaft, then insert rear wheel (M) on the shaft. Insert the 'R' lock pin (O) into the hole on the end of the shaft to lock the wheel. Snap the hub cap (N) on to the wheel. Repeat the same steps at the other end of the shaft. Please notice you must install the hub cap on to the wheel, otherwise the 'R' lock pin will come loose result in wheel do not work. (fig. 6)
7. For wet vacuum cleaning, install the supplied foam filter. (fig. 7) See page 9 for filter installation.
8. Your vacuum comes ready for dry vacuum cleaning with PET cartridge filter pre-

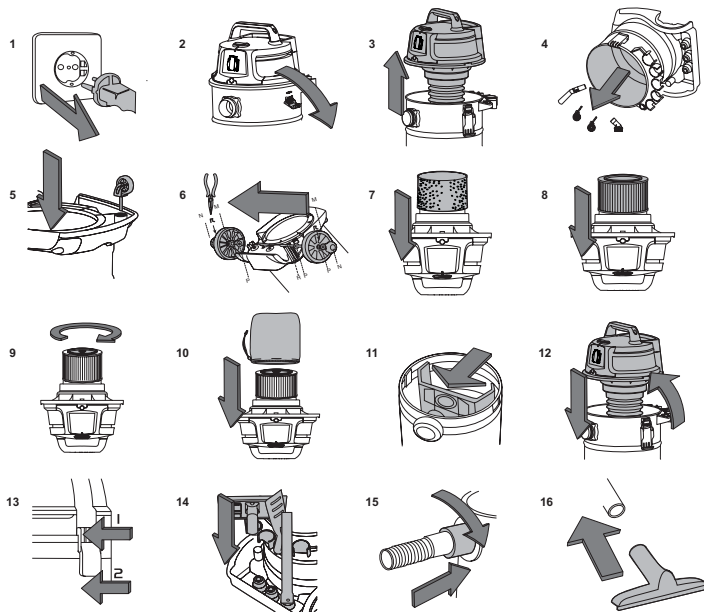

# SWITCHING ON/OFF

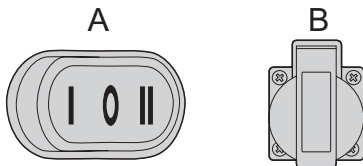

**A: Function switch ON/OFF switch**  
**B: Outlet-socket**

Connect the mains plug.

1. Switching on the vacuum cleaner:

Press **I**

2. Switch on electrical appliance + vacuum cleaner:

Press **II**

Switch on electrical appliance. Only connect electrical appliances with a maximum power rating of 2200W. Switching on the electrical appliance automatically switches on the vacuum cleaner. Once the electrical appliance has been switched off, the vacuum cleaner switches off following a time lapse.

3. Switching off the vacuum cleaner:

Press **O**

## DRY-VACUUM OPERATION

**WARNING: BE SURE TO READ, UNDERSTAND, AND APPLY INFORMATION, ENTITLED 'SAFETY INSTRUCTIONS & WARNINGS'. DO NOT VACUUM IN AREAS WITH FLAMMABLE GASES, VAPORS, OR EXPLOSIVE DUSTS IN THE AIR. FLAMMABLE GASES OR VAPORS INCLUDE BUT ARE NOT LIMITED TO; LIGHTER FLUID, SOLVENT TYPE CLEANERS, OIL-BASE PAINTS, GASOLINE, ALCOHOL OR AEROSOL SPRAYS. EXPLOSIVE DUSTS INCLUDE BUT ARE NOT LIMITED TO; COAL, MAGNESIUM, GRAIN OR GUN POWDER. TO REDUCE THE RISK OF HEALTH**

**HAZARDS FROM VAPORS OR DUST, DO NOT VACUUM TOXIC MATERIALS.**

**WARNING: DO NOT PLUG IN POWER CORD TO POWER OUTLET. MAKE SURE PLUG IS DISCONNECTED BEFORE CHANGING AND CLEANING FILTERS.**

1. Verify that the power cord is disconnected from the outlet. (fig.1)
2. In order to prepare your vacuum for dry vacuuming, verify that the PET cartridge filter is securely mounted. Make sure the filter is pushed in until it stops against the power head. (fig.2) (Your Wet/Dry Vac comes with the cartridge filter pre-installed, if not see page 16 for installation instructions.)
3. Place filter retainer on top of PET cartridge filter and tighten down by turning the retainer handle clockwise. (fig.3)
4. Put the PRE cloth filter over the filter tray with the attached PET cartridge filter. (fig.4)
5. Optional, for improved dust filtering, fit collection bag flange onto the inlet stub, taking care not to damage the bag. (fig.5)
6. Place the power head back on the container, and secure it in place using the latches. (fig.6)

### OPERATING INSTRUCTIONS: DRY VACUUMING

7. Insert the locking end of the hose into the vacuum port and screw in place. Push the required attachment onto the free end of the hose or extension. (fig.7)
8. Plug in the power cord into the outlet. (fig.8)
9. Turn the motor on by flipping the switch to the 'I' ON position. (fig.9)
10. Once you have completed vacuuming, flip the switch to the 'O' OFF position and unplug the power cord from the outlet.

**O = OFF** (Switching off the vacuum cleaner)

**I = ON** (Switching on the vacuum cleaner)

**II = ON** (Switch on electrical appliance)

**DO NOT USE COLLECTION BAG FOR LIQUID VACUUMING**

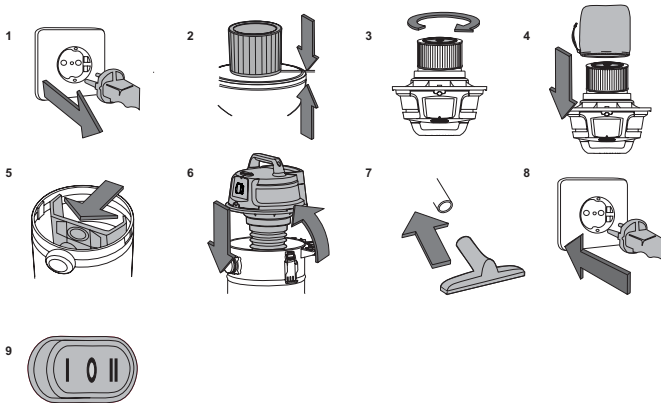

- the container is clean and free from dust and dirt.
2. Remove collection bag & cartridge filter, then carefully install the foam sleeve filter over the filter cage and place the power head back on the container. (fig. 2) See filter installing instructions on page 9.
3. Fit the desired nozzle to the vacuum hose. (fig.3)
4. Verify that the switch is in the 'O' OFF position before plugging the power cord into the outlet. (fig.4)
5. Turn the motor on by flipping the switch to the 'I' ON position. (fig.5)

#### OPERATING INSTRUCTIONS – WET VACUUMING

6. Turn the vacuum off.

**IMPORTANT!** When vacuuming large quantities of liquids, do not immerse the nozzle completely in the liquid; leave a gap at the tip of the nozzle opening to allow air inflow. The machine is fitted with a float valve that stops the suction action when the container reaches its maximum capacity. You will notice an increase in motor speed. When this happens, turn off the machine, disconnect from power supply, and drain the liquid into a suitable receptacle or drain. To continue vacuuming, refit the container with the drain cap. After wet vacuuming, turn the machine off and remove plug from power supply. Empty the container, clean and dry the inside and outside before storage.

**REMEMBER!** The collection bag must be removed in wet vacuuming.

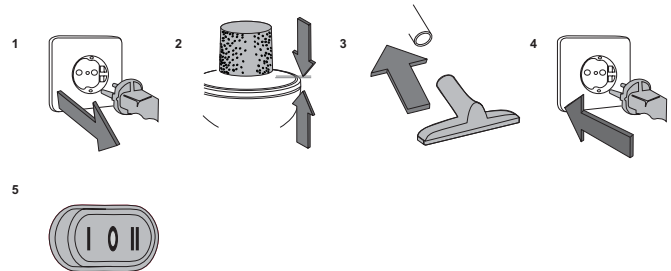

## 7 WET-VACUUM OPERATION

**WARNING:** BE SURE TO READ, UNDERSTAND, AND APPLY INFORMATION, ENTITLED 'SAFETY INSTRUCTIONS & WARNINGS'. DO NOT VACUUM IN AREAS WITH FLAMMABLE GASES, VAPORS, OR EXPLOSIVE DUSTS IN THE AIR. FLAMMABLE GASES OR VAPORS INCLUDE BUT ARE NOT LIMITED TO; LIGHTER FLUID, SOLVENT TYPE CLEANERS, OIL-BASE PAINTS, GASOLINE, ALCOHOL OR AEROSOL SPRAYS. EXPLOSIVE DUSTS INCLUDE BUT ARE NOT LIMITED TO; COAL, MAGNESIUM, GRAIN OR GUN POWDER. TO REDUCE THE RISK OF HEALTH HAZARDS FROM VAPORS OR DUST, DO NOT VACUUM TOXIC MATERIALS.

**WARNING:** DO NOT PLUG IN POWER CORD TO POWER OUTLET. MAKE SURE PLUG IS DISCONNECTED BEFORE CHANGING AND CLEANING FILTERS.

DO NOT USE THE CARTRIDGE FILTER FOR LIQUID VACUUMING.

DO NOT USE COLLECTION BAG FOR LIQUID VACUUMING.

#### OPERATING INSTRUCTIONS – WET VACUUMING

1. Verify that the power cord is disconnected from the outlet. (fig.1) Make sure that

# MAINTENANCE

**WARNING: DO NOT PLUG IN POWER CORD TO POWER OUTLET. MAKE SURE PLUG IS DISCONNECTED BEFORE CHANGING AND CLEANING FILTERS.**

1. Verify that the power cord is disconnected from the outlet. (fig.1)
2. Disconnect the hose from the vacuum, turning large end in counter clockwise direction. (fig.2)
3. Undo the latches and remove the power head from the container. (fig.3)
4. Clear all dirt or debris from the container and hose. (fig.4)
5. Check the hose, attachments, and power cord to verify that they have not been damaged.

**IMPORTANT! Clean or change the cartridge filter regularly for best performance. ALWAYS USE CARTRIDGE FILTER FOR DRY VACUUMING. If the machine is used with out the cartridge filter, the motor will burn out and the warranty will be voided. Always keep spare filters on-hand.**

**NOTICE! The filters included are made of high quality materials designed to stop small dust particles. The cartridge filter should be used for dry pick-up only. A dry cartridge filter is necessary to pick up dust. If the cartridge filter is wet, it will clog quickly and be very difficult to clean. Handle the filter carefully when removing it for cleaning and replacing it. Check the filters for tears or small holes, a small hole can let dust pass through and out of the cleaner. Do not use a filter with holes or tears, replace it immediately.**

**WARNING! ALWAYS DISCONNECT THE PLUG FROM THE POWER OUTLET BEFORE REMOVING THE POWER HEAD FROM CONTAINER.**

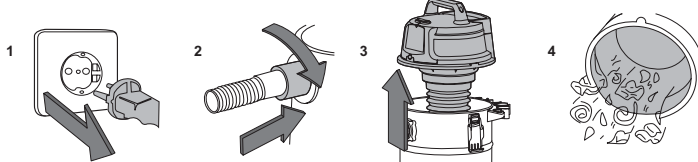

## INSTALLING & CLEANING CARTRIDGE FILTERS

### Installing Cartridge Filter

1. Verify that the power cord is disconnected from the outlet. (fig.1)
2. Remove power head and place in upside down position.
3. Slide the cartridge filter down over the filter cage and carefully push filter in until it stops against the power head. (fig.2)
4. Place filter retainer on top of cartridge filter and tighten down by turning retainer handle clockwise. (fig.3 & 4)

### Removing and Cleaning Cartridge Filter

1. Unlock and remove the filter retainer by turning retainer handle counter clockwise.
2. Carefully hold and pull the cartridge filter up for removal. (fig.5)
3. Clean the cartridge filter by gently tapping or brushing dirt off. Cleaning should not be done indoors in living areas. For optimal performance a new filter is recommended.
4. Install cleaned or new filter into place as instructed above in steps 2 and 3 of installing Cartridge Filter.
5. Wet filters should be removed and allowed to air dry for 24 hours before installing onto the filter cage.

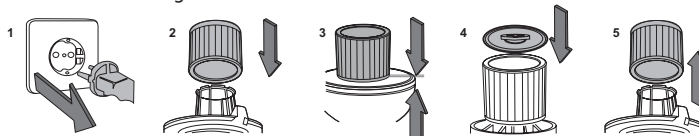

## INSTALLING & CLEANING FOAM SLEEVE FILTER

### Installing Foam Sleeve Filter

1. Verify that the power cord is disconnected from the outlet. (fig.1)
1. Remove power head and place in upside down position. Follow instructions to remove cartridge filter.
2. Carefully slide foam sleeve filter down over the filter cage making sure the whole cage is covered.(fig.2)
3. Replace the power head on to the container.



### Cleaning Foam Sleeve Filter

1. With the removed power head in the upside down position, carefully remove foam sleeve filter. (fig. 3)
2. Use a mild soap and water solution to wash foam sleeve filter and rinse with clean water. (fig. 4)
3. Allow filter to air dry before installing and using again.

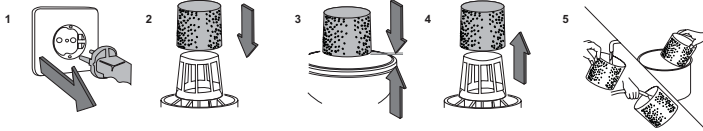

## INSTALLING & CLEANING HEPA FILTER

### Installing HEPA FILTER

1. Verify that the power cord is disconnected from the outlet. (fig.1)
2. Unlock the filter door by lifting the lock tab UP to the unlocked position and pull the door out. (fig. 2 & 3)
3. Remove the HEPA filter cartridge from the vacuum. (fig.4)

### Cleaning HEPA Filter

4. Clean filter by brushing dirt off. For optimal performance a new filter is recommended. (fig.5)
5. Install the cleaned or new filter into place. (fig. 6)
6. Insert the filter door tabs into the upper slots and lock the filter door into place. (fig. 7 & 8)

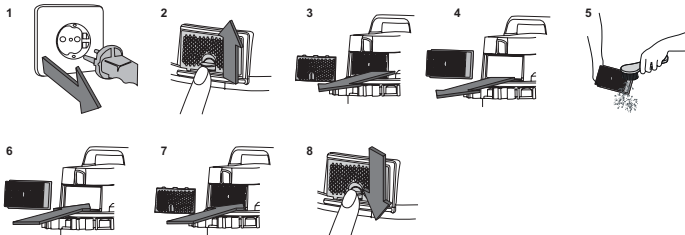

## TROUBLESHOOTING

Symptom	Possible Causes	Corrective Action
Vacuum will not operate	1) No power supply.	1) Check power supply – cord, breakers, fuses.
	2) Faulty power cord.	2) Unplug and check the power cord. If damaged, have it repaired by a professional.
	3) Container full.	3) Empty container.
Dust comes out from motor cover.	1) The PET cartridge filter or collection bag is missing or damaged.	1) Attach or replace PET cartridge filter or collection bag.
Reduced efficiency and motor/speed vibration.	1) There is a blockage in the nozzle or hose, or the container inlet. Or dust filter blocked by fine dust.	1) Check nozzle, hose and container inlets for blockage. Take off the filter and clean it. Or install new cartridge filter.

# PARTS LIST -EXPLODED VIEW

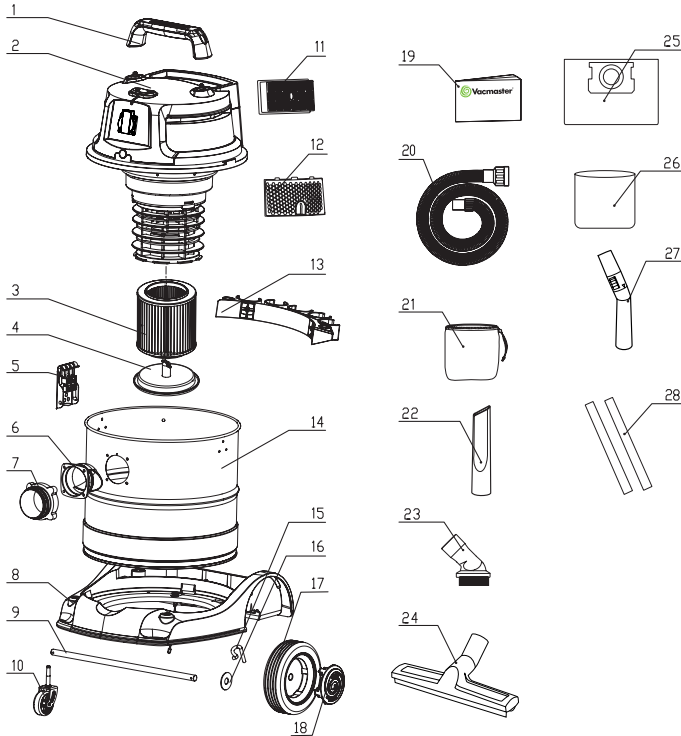

**VK1520SIWC Manual Parts List**

Key Number	Drawing Number	Description	Quantity
1	VK01SR.10.05	Handle	1
2	VK20SR.10.00	Power Head Assembly	1
3	FV9563.02.00	Cartridge Filter	1
4	FV9546.01.20.00	Filter Retainer	1
5	TVQTDK.12.00	Latch Assembly	2
6	TVQTXK.05.01	Vacuum Port Deflector	1
7	TVQTXK.05.02	Vacuum Port Assembly	1
8	VK21SR.22.00	Base	1
9	VB07SR.00.02	Wheel Shaft	1
10	TVQTIJL.23.00	Caster Foot	2
11	VK21SR.12.00	HEAP Rated Filter	1
12	VK21SR.11.00	HEAP Filter Door	1
13	FV8201.05.01	Accessory Shelves	1
14	VK21SR.30.01	Container	1
15	BOD1ZZ.03.02	'R' Lock Pins	2
16	BOC1YX.14.BC	Washer	4
17	TVQTGL.16.00	Wheel	2
18	TVQTGL.16.04	Hub Caps	2
19		Operator's Manual	1
20	FV8804.01.00	Hose	1
21	FV9644.04.00	PRE Cloth Filter	1
22	FV8772.01.01	Crevice Car Nozzle	1
23	FV8773.01.00	Round Dust Brush	1
24	FV8704.03.00	Floor Brush / squeegee	1

25	FV9612.01.00.01	Dust Bag	1
26	F V9503.02.00	Foam Sleeve Filter	1
27	FV8322.02.00	Air Control Handle	1
28	FV8943.01.00	2 Coated Tube	2



**Declaration Of Conformity**  
**We, Importer**  
**Suzhou Cleva Electric Appliance Co., Ltd.**  
**8#, Ting Rong Street,**  
**Suzhou Industrial District**  
**215122 Suzhou, Jiangsu Province**  
**PEOPLE'S REPUBLIC OF CHINA**

**Declare that the product**  
**VK1520SIWC**  
**Wet & Dry Vacuum Cleaner**

Complies with the essential health and safety requirements of the following directives:

2004/108/EC - EMC Directive  
2006/95/EC - Low Voltage Directive  
2002/95/EC – ROHS Directive  
2002/96/EC – WEEE Directive

Standards and technical specification referred to:

EN60335-1/A13:2008  
EN60335-2-2/A2:2006  
EN62233:2008  
EN55014-1:2006  
EN55014-2/A1:2001  
EN61000-3-2:2006  
EN61000-3-3:2005

**Authorise Signatory**

Date: 07/26/2010

A handwritten signature in black ink, appearing to be "Jim", written over a light blue horizontal line.

Signature:

Name: Will Zhou



(EC conformity Mark)

**Distributed by:**



**MADE IN P. R. C.**

**VK1520SIWC 950203**