

Repair Manual

AirPower1, 2, 3
Models Z-1100001, Z-1200001, Z-13026001
Pneudraulic Riveter



Repair manual

- *specified for riveting tools SERIE 1 (AirPower1, EZM1000, E-500RA)*
- *specified for riveting tools SERIE 2 (AirPower2, EZM2000, E-640RA)*
- *specified for riveting tools SERIE 3 (AirPower3, E-649RA)*

Content:

1. Abbreviations
2. General instructions
3. Proper function of riveting tool
4. Assembly drawing of riveting tool
5. Informative parts list of riveting tool
6. Instructions for assembling and disassembling – steps 1-18
7. Instructions for assembling and disassembling of sub-assemblies – steps 19-26
8. List of defects of riveting tool
9. Description of defects and their remedies
10. Service set
11. List of special tools in the service set

1. Abbreviations:

CA - compressed air

MP - special tool (assembly jig)

D - defect

2. General instructions:

1. Riveting tool is always disconnected from the compressed air, unless otherwise stated
2. All threads are clockwise
3. Riveting tool is gripped in a stand (see chapter 10) while assembling and disassembling, unless otherwise stated
4. Before assembling, wash the disassembled parts in degreasing solution and insufflate with compressed air, wipe with a cloth
5. While assembling, lubricate the sealing (O-rings, pneumatic seals) and related opposite surfaces with oil MOGUL LV 2-3, unless stated otherwise

3. Proper function of riveting tool:

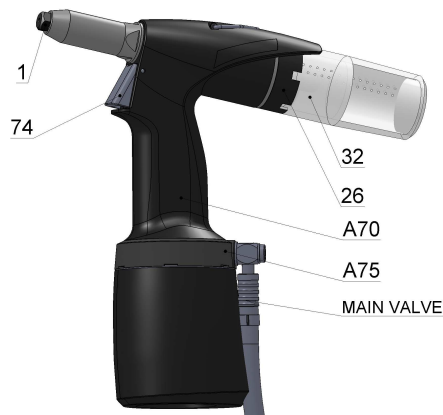

Operator activity	Tool function
<p>Connect the riveting tool to CA, if the tool is equipped with main valve, turn it on. Pos. 74 is on the front extreme position, not pressed</p> <p>Suction is switched on</p>	<p>CA leaks through outlets in pos. 32</p>
<p>Press and lock pos. 74 (after pressing pos. 74 move it up cca 1,5 mm), then release pos. 74 (refers only to riveting tools equipped with lock function)</p> <p>Suction switches off</p>	<p>CA does not leak, pos. 74 keeps locked</p>
<p>Release locking of pos. 74 (move down to the stop) and release pos. 74 (refers only to riveting tools equipped with lock function)</p> <p>Suction switches on</p>	<p>CA is blown out from pos. A75 and it leaks through outlets in pos. 32</p>
<p>Put on or suck BR on to pos. 1</p>	<p>BR is held on the front of pos. 1 (vertically) with the help of CA, CA leaks through outlets in pos. 32</p>
<p>Press pos. 74, the rivet rivets on</p>	<p>CA does not leak</p>
<p>Release pos. 74, the nail from the blind rivet goes to pos. 32</p>	<p>CA is blown out from pos. A75 and it leaks through outlets in pos. 32</p>
<p>Move pos. 32 around a slight amount to position 1 (interposition), suction switches off, pos. 32 cannot be removed</p>	<p>CA does not leak, pos. 32 is locked in position 1</p>
<p>Move pos. 32 around a slight amount to position 0 (to the stop) and then remove pos. 32</p>	<p>CA does not leak, the position 0 is locked, pos. 26 cannot be turned</p>
<p>Put on pos. 32 and move around a slight amount to position 2 (to the stop)</p> <p>Suction switches on</p>	<p>CA leaks through outlets in pos. 32</p>

4. Air Power 1 Model Z-1100001 Pneudraulic Riveter Assembly Drawing

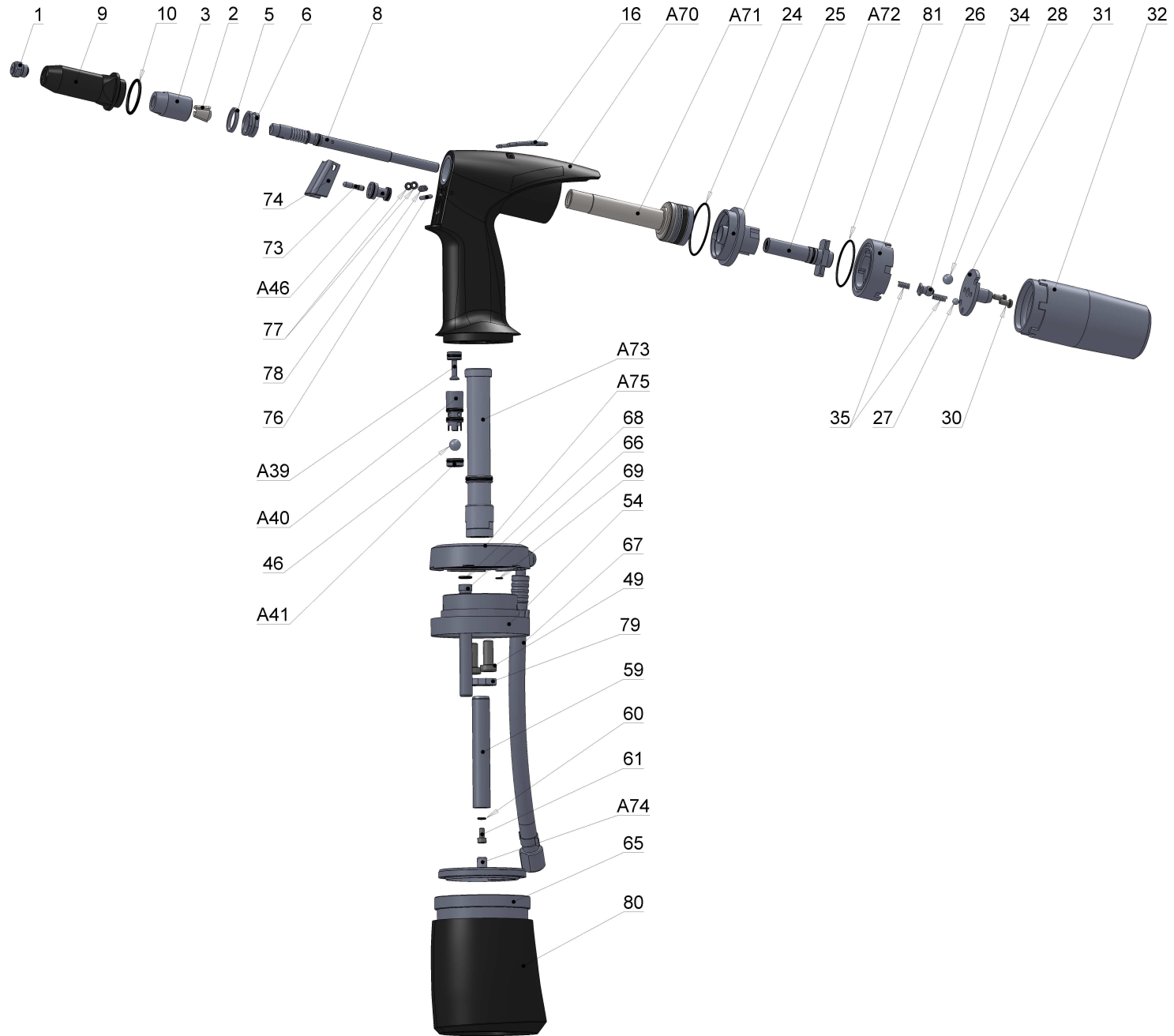

4. Air Power 2 Model Z-1200001 Pneudraulic Riveter Assembly Drawing

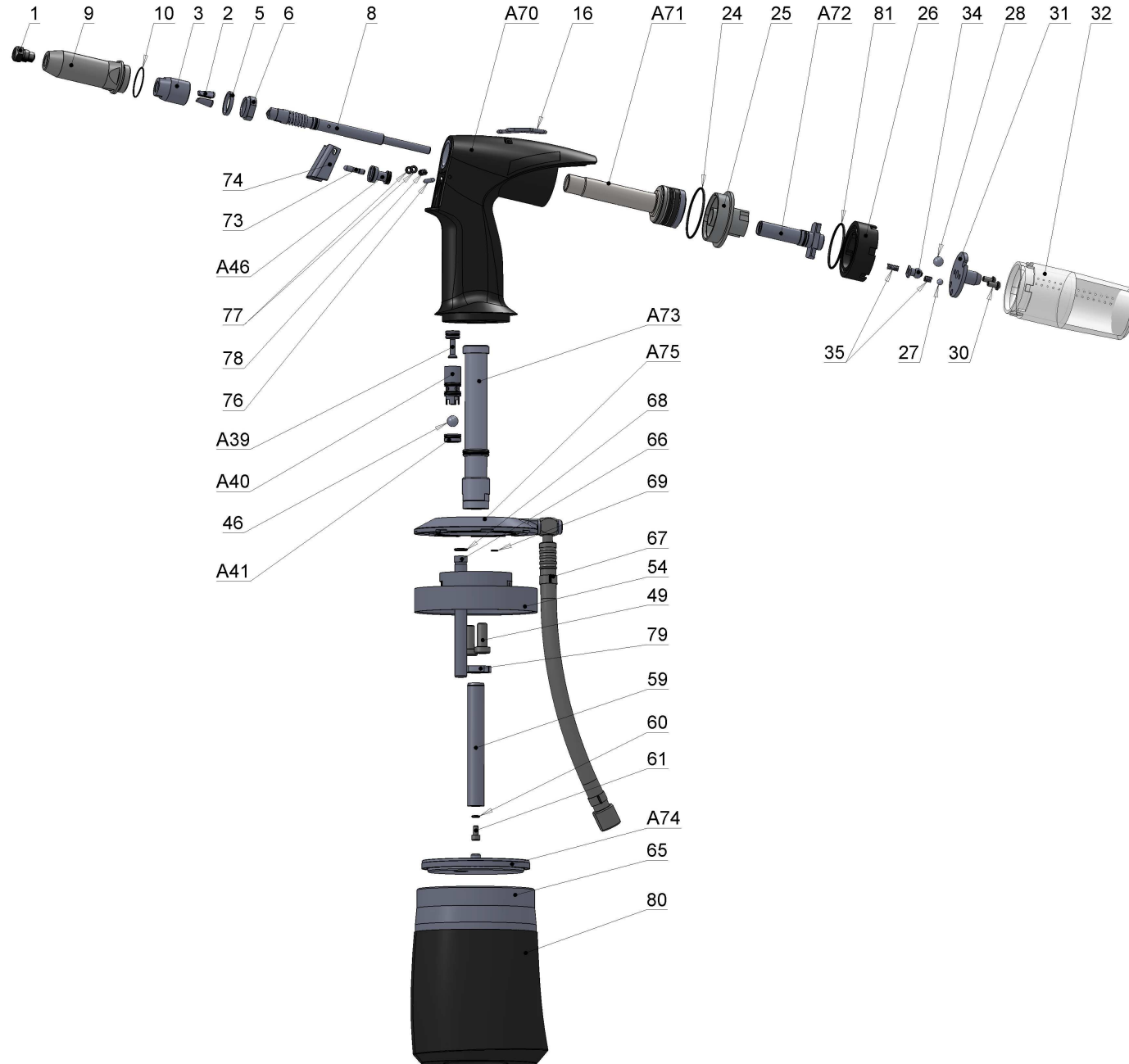

4. Air Power 3 Model Z-13026001 Pneudraulic Riveter Assembly Drawing

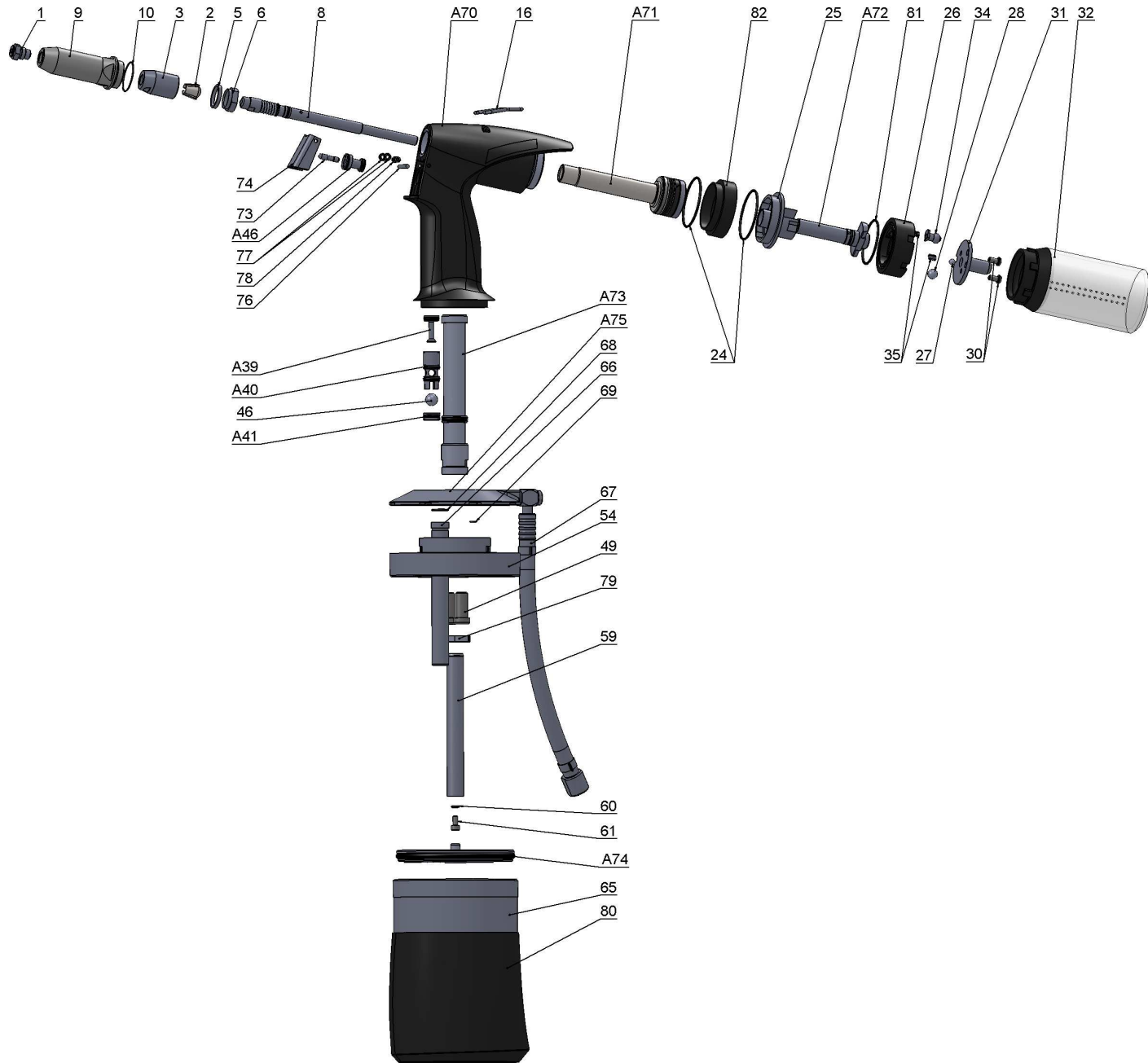

5. Air Power 2 Model Z-1200001 Pneudraulic Riveter Parts List

Position	Article number	Name	Qty
1	D-13001XX	Nose-pieces	1 pcs
2	S-1100153	Jaws Emhart 13300	1 set
3	D-1300103	Clamping sleeve	1 pcs
5	D-1100301	Scraper ring	1 pcs
6	D-1100401	Nut HP (M15,5x1)	1 pcs
8	S-1300503	Conduit suction complete	1 pcs
	801 S-1300523	Conduit suction	1 pcs
	802 N-2103700710160	O - ring 7,1/1,6 Sh 70	1 pcs
	803 D-1200530	Jaw pusher spring	1 pcs
	804 D-1200203	Jaw pusher with thread	1 pcs
	805 D-1100550	Washer of spring	1 pcs
9	D-1100601	Front nozzle	1 pcs
10	N-2103702500250	O - ring 25/2,5 Sh 70	1 pcs
A70	S-1207701	Hydraulic body complete	1 pcs
	11 S-1200701	Hydraulic body	1 pcs
	12 D-1106100	Guiding band	1 pcs
	13 N-2200070155426	X - ring 15,54x2,62 Sh 70	1 pcs
	14 N-2040000000160	Stepseal 16	1 pcs
	15 N-2103701717178	O - ring 17,17/1,78 Sh 70	1 pcs
16	D-1100800	Hanger	1 pcs
A71	S-1200902	Hydraulic piston complete	1 pcs
	17 D-1200902	Hydraulic piston	1 pcs
	18 N-2040000000320	Stepseal 32	1 pcs
	19 N-2103702200300	O - ring 22/3 Sh 70	1 pcs
	20 N-2200070249935	X - ring 24,99x3,53 Sh 70	1 pcs
	21 N-2104001200250	O - ring 12/2,5 VITON	1 pcs
	22 D-1106200	Guiding band	1 pcs
	23 D-1106600	Seal 32	1 pcs
24	N-2103704200150	O - ring 42/1,5 Sh 70	1 pcs
25	D-1201000	Nut of body	1 pcs
26	D-1101101	Wheel	1 pcs
27	N-3600000000001	Steel ball 4,762	1 pcs
28	N-3600000000002	Steel ball 8	1 pcs
A72	S-1201200	Bush complete	1 pcs
	29 D-1301200	Endstop	1 pcs
	33 N-2103700760130	O - ring 7,6/1,3 Sh 70	1 pcs
	36 N-2103701000150	O - ring 10/1,5 Sh 70	1 pcs
	37 D-1201700	Piston	1 pcs
	38 N-2103700900130	O - ring 9/1,3 Sh 70	1 pcs
30	N-1000738000408	Screw M4x10 imbus zinc	2 pcs
31	D-1101300	Hood	1 pcs
32	S-1201402	Mandrel container	1 pcs
34	D-1101500	Small pin	1 pcs
35	D-1101600	Spring	2 pcs
A73	S-1207802	Insert PP complete	1 pcs
	39 N-2103901000200	O - ring 10/2 Sh 90	1 pcs
	4001 D-1201802	Insert PP	1 pcs
	4005 N-2140000000140	Glyd - ring 14x21,3x3,2	1 pcs
	4006 N-2103701712262	O - ring 17,12/2,62 Sh 70	1 pcs
	4007 N-2104001400200	O - ring 14/2 VITON	1 pcs
	4008 D-1106300	Guiding band	1 pcs
	4009 D-1301812	Valve washer	1 pcs
	4010 D-1301822	Valve insert	1 pcs
	4011 N-2104001200250	O - ring 12/2,5 VITON	1 pcs
	4012 N-3600000000006	Steel ball 4	1 pcs
	41 N-2104001800220	O - ring 18/2,2 VITON	1 pcs

Position	Article number	Name	Qty
A39	S-1101900	Valve piston complete	1 pcs
	42 D-1101900	Valve piston	1 pcs
	43 N-2103700800200	O - ring 8/2 Sh 70	1 pcs
A40	S-1102000	Valve body complete	1 pcs
	44 N-2103701000200	O - ring 10/2 Sh 70	2 pcs
	45 D-1102000	Valve body	1 pcs
46	N-2406696500090	Plastic ball PUR 9	1 pcs
A41	S-1102100	Valve bottom complete	1 pcs
	44 N-2103701000200	O - ring 10/2 Sh 70	1 pcs
	47 D-1102100	Valve bottom	1 pcs
	48 N-2103700900200	O - ring 9/2 Sh 70	1 pcs
49	N-1000798408200	Screw M8x20 DIN 7984	2 pcs
A75	S-1202305	Air supply complete	1 pcs
	51 N-2103706000200	O - ring 60/2 Sh 70	1 pcs
	52 N-2103706300200	O - ring 63/2 Sh 70	1 pcs
	53 D-1202305	Air supply	1 pcs
67	S-1203203	Aircoupling	1 pcs
	A43 S-1203213	Aircoupling body compl.	1 pcs
	A44 S-1103221	Aircoupl. rot. part compl.	1 pcs
	6705 N-1400471000012	Retaining ring 12	1 pcs
54	D-1202400	Body bottom	1 pcs
59	D-1202701	Pneumatic piston	1 pcs
60	N-2103900400150	O - ring 4/1,5 Sh 90	1 pcs
61	N-1000091204080	Screw M4x8 DIN 912	1 pcs
A74	S-1202801	Pneumatic piston compl.	1 pcs
	62 D-1202801	Pneumatic piston	1 pcs
	63 N-2300007140000	Lip seal 14	1 pcs
	64 D-1206400	Seal 90	1 pcs
65	D-1203000	Pneu cylinder	1 pcs
66	D-1203100	Tube	1 pcs
68	N-2104000700200	O - ring 7/2 VITON	1 pcs
69	N-2103700400150	O - ring 4/1,5 Sh 70	1 pcs
A46	S-1103300	Trigger body complete	1 pcs
	70 N-2103700700200	O - ring 7/2 Sh 70	1 pcs
	71 D-1103300	Trigger body	1 pcs
	72 N-2104000400100	O - ring 4/1 VITON	2 pcs
	75 N-2103700900130	O - ring 9/1,3 Sh 70	1 pcs
73	D-1103400	Trigger piston	1 pcs
74	D-1103500	Trigger	1 pcs
76	D-1103800	Trigger pin	1 pcs
77	D-1103900	Trigger ring	2 pcs
78	N-1500000010004	Spring of trigger	1 pcs
79	D-1103600	Nut of body	1 pcs
80	D-1203700	Soft sleeve	1 pcs
81	N-2103703600200	O - ring 36/2 Sh 70	1 pcs

5. Air Power 3 Model Z-13026001 Pneudraulic Riveter Parts List

Position	Article number	Name	Qty
1	D-13001XX	Nose-pieces	1 pcs
2	S-1100153	Jaws Emhart 13300	1 set
3	D-1300103	Clamping sleeve	1 pcs
5	D-1100301	Scraper ring	1 pcs
6	D-1100401	Nut HP (M15,5x1)	1 pcs
8	S-1300503	Conduit suction complete	1 pcs
	801 S-1300523	Conduit suction	1 pcs
	802 N-2103700710160	O - ring 7,1/1,6 Sh 70	1 pcs
	803 D-1200530	Jaw pusher spring	1 pcs
	804 D-1200203	Jaw pusher with thread	1 pcs
	805 D-1100550	Washer of spring	1 pcs
9	D-1300601	Front nozzle	1 pcs
10	N-2103702500250	O - ring 25/2,5 Sh 70	1 pcs
A70	S-1307701	Hydraulic body complete	1 pcs
	11 S-1300701	Hydraulic body	1 pcs
	12 D-1106100	Guiding band	1 pcs
	13 N-2200070155426	X - ring 15,54x2,62 Sh 70	1 pcs
	14 N-2040000000160	Stepseal 16	1 pcs
	15 N-2103701717178	O - ring 17,17/1,78 Sh 70	1 pcs
16	D-1100800	Hanger	1 pcs
A71	S-1300901	Hydraulic piston complete	1 pcs
	17 D-1300901	Hydraulic piston	1 pcs
	18 N-2040000000320	Stepseal 32	1 pcs
	19 N-2103702200300	O - ring 22/3 Sh 70	1 pcs
	20 N-2200070249935	X - ring 24,99x3,53 Sh 70	1 pcs
	21 N-2104001200250	O - ring 12/2,5 VITON	1 pcs
	22 D-1106200	Guiding band	1 pcs
	23 D-1106600	Seal 32	1 pcs
24	N-2103704200150	O - ring 42/1,5 Sh 70	1 pcs
25	D-1101000	Nut of body	1 pcs
26	D-1101101	Wheel	1 pcs
27	N-3600000000001	Steel ball 4,762	1 pcs
28	N-3600000000002	Steel ball 8	1 pcs
A72	S-1301200	Bush complete	1 pcs
	29 D-1301200	Endstop	1 pcs
	33 N-2103700760130	O - ring 7,6/1,3 Sh 70	1 pcs
	36 N-2103701000150	O - ring 10/1,5 Sh 70	1 pcs
	37 D-1301700	Piston	1 pcs
	38 N-2103700900130	O - ring 9/1,3 Sh 70	1 pcs
30	N-1000738000408	Screw M4x8 imbus zinc	2 pcs
31	D-1301300	Hood	1 pcs
32	S-1301400	Mandrel container	1 pcs
34	D-1101500	Small pin	1 pcs
35	D-1101600	Spring	1 pcs
A73	S-1307802	Insert PP complete	1 pcs
	39 N-2103901000200	O - ring 10/2 Sh 90	1 pcs
	4001 D-1301802	Insert PP	1 pcs
	4005 N-2140000000140	Glyd - ring 14x21,3x3,2	1 pcs
	4006 N-2103701712262	O - ring 17,12/2,62 Sh 70	1 pcs
	4007 N-2104001400200	O - ring 14/2 VITON	1 pcs
	4008 D-1106300	Guiding band	1 pcs
	4009 D-1301812	Valve washer	1 pcs
	4010 D-1301822	Valve insert	1 pcs
	4011 N-2104001200250	O - ring 12/2,5 VITON	1 pcs
	4012 N-3600000000006	Steel ball 4	1 pcs
	41 N-2103702000130	O - ring 20/1,3 Sh70	1 pcs

Position	Article number	Name	Qty
A39	S-1301900	Valve piston complete	1 pcs
	42 D-1301900	Valve piston	1 pcs
	43 N-2103701000150	O - ring 10/1,5 Sh 70	1 pcs
A40	S-1302000	Valve body complete	1 pcs
	44 N-2103701000200	O - ring 10/2 Sh 70	2 pcs
	45 D-1302000	Valve body	1 pcs
46	N-2406696500100	Plastic ball PUR 10	1 pcs
A41	S-1302100	Valve bottom complete	1 pcs
	44 N-2103701000200	O - ring 10/2 Sh 70	1 pcs
	47 D-1302100	Valve bottom	1 pcs
	48 N-2103701000150	O - ring 10/1,5 Sh 70	1 pcs
49	D-1304000	Screw M10 modif.	2 pcs
A75	S-1302305	Air supply complete	1 pcs
	51 N-2103706000200	O - ring 60/2 Sh 70	1 pcs
	52 N-2103706300200	O - ring 63/2 Sh 70	1 pcs
	53 D-1302305	Air supply	1 pcs
67	S-1203203	Aircoupling	1 pcs
	A43 S-1203213	Aircoupling body compl.	1 pcs
	A44 S-1103221	Aircoupl. rot. part compl.	1 pcs
	6705 N-1400471000012	Retaining ring 12	1 pcs
54	D-1302401	Body bottom	1 pcs
59	D-1302701	Pneumatic piston	1 pcs
60	N-2103900400150	O - ring 4/1,5 Sh 90	1 pcs
61	N-1000091204080	Screw M4x8 DIN 912	1 pcs
A74	S-1302801	Pneumatic piston compl.	1 pcs
	58 N-2103700500150	O - ring 5/1,5 Sh 70	1 pcs
	62 D-1302801	Pneumatic piston	1 pcs
	63 N-2103701400200	O - ring 14/2 Sh 70	1 pcs
	64 N-2103709200450	O - ring 92/4,5 Sh 70	1 pcs
65	D-1303000	Pneu cylinder	1 pcs
66	D-1303100	Tube	1 pcs
68	N-2103701200150	O - ring 12/1,5 Sh 70	1 pcs
69	N-2103700400150	O - ring 4/1,5 Sh 70	1 pcs
A46	S-1103300	Trigger body complete	1 pcs
	70 N-2103700700200	O - ring 7/2 Sh 70	1 pcs
	71 D-1103300	Trigger body	1 pcs
	72 N-2104000400100	O - ring 4/1 VITON	2 pcs
	75 N-2103700900130	O - ring 9/1,3 Sh 70	1 pcs
73	D-1103400	Trigger piston	1 pcs
74	D-1103500	Trigger	1 pcs
76	D-1103800	Trigger pin	1 pcs
77	D-1103900	Trigger ring	2 pcs
78	N-1500000010004	Spring of trigger	1 pcs
79	D-1103600	Nut of body	1 pcs
80	D-1303700	Soft sleeve	1 pcs
81	N-2103703600200	O - ring 36/2 Sh 70	1 pcs
82	D-1304101	Ring of body	1 pcs
86	N-2103703800200	O - ring 38/2 Sh 70	1 pcs

6. Instructions for assembling and disassembling - steps 1-18

Provided the disassembly and assembly procedure is identical for all mentioned types of riveting tools, it is demonstrated only at the tool SERIE 1.

Potential differences at tools serie2 and SERIE 3 are depicted and described in each individual step.

Step 1

Disassembly:

Remove pos. 32 from pos. 26 (see chapter 3)



Assembly:

Put pos. 32 on recess in pos. 26 (see chapter 3).

Step 2

Disassembly:

Put MP14 on pos. 80, loosen and screw out pos. 65 and pos. 80.



Assembly:

Screw on pos. 65 and pos. 80, put on MP14, tighten and put coloured warranty plug. The process is different when using new parts pos. 65 and pos. 80 - at first screw pos. 65 on, put on MP14, tighten and put coloured warranty plug. Then put glue PATTEX EXPRESS FIX PL600 on pos. 65, put pos. 80 on by twisting it slightly until it reaches the position on the picture.

Step 3

Disassembly:

Tool SERIE 1 and SERIE 2 - Release pos. A74.

Tool SERIE 3 - Pos. A74 is secured by pos. 58 against unintended shifting out of pos. 59. To remove pos. A74, pull it down while holding pos. 59 (by hand).

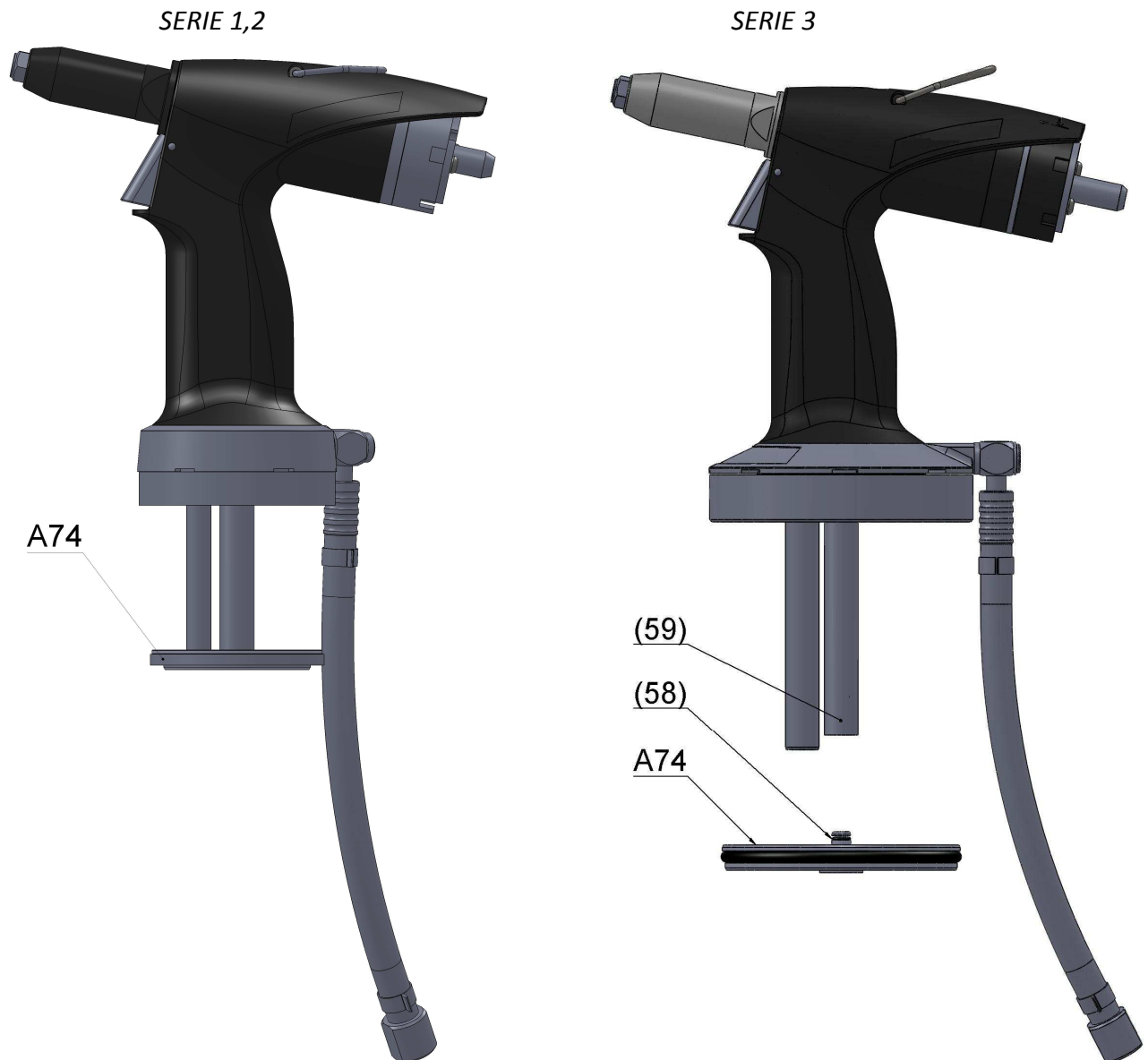

Assembly:

Tool SERIE 1 and SERIE 2 - Put on pos. A74.

Tool SERIE 3 - Put on pos. A74 while holding pos. 59 (by hand).

Step 4

Disassembly:

Put MP15A on pos. 59, then press MP15A with wrench, screw out pos. 61 with imbus key nr. 3 and take pos. 60 and pos. 59 out. Then pour out hydraulic oil from the riveting tool to a cup.

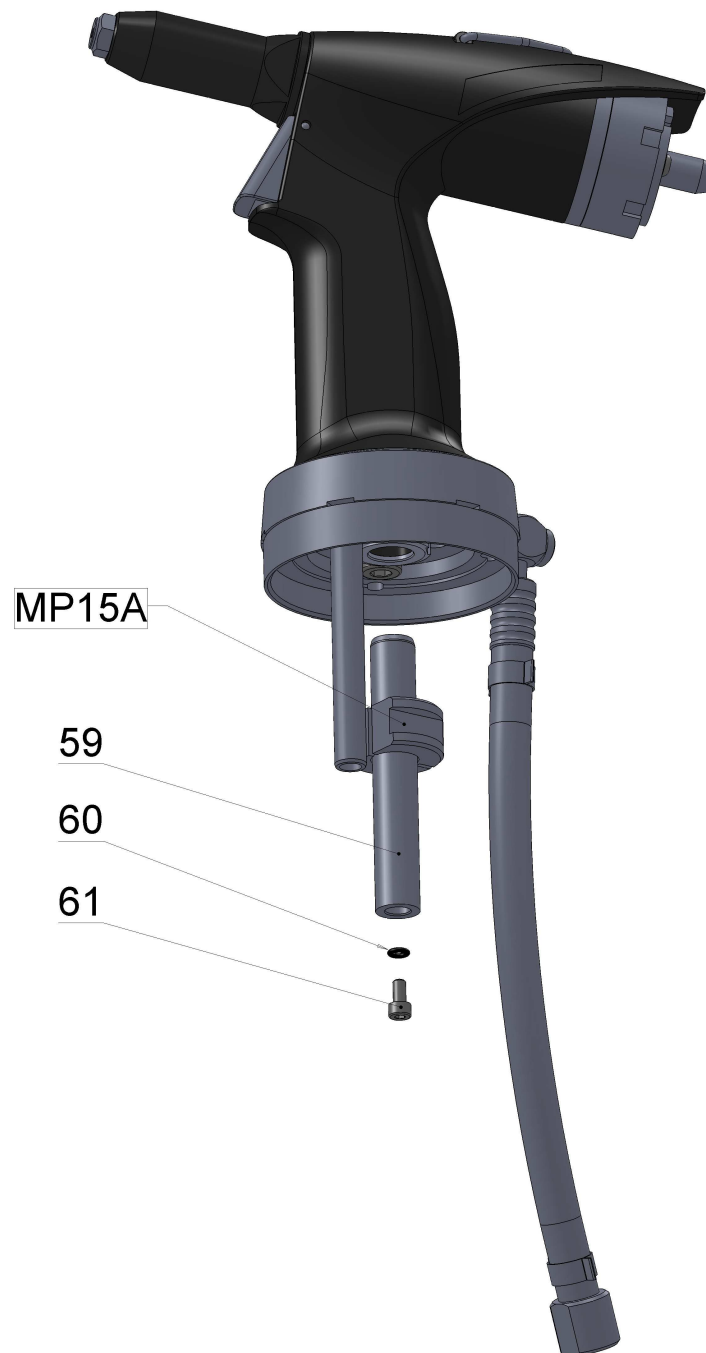

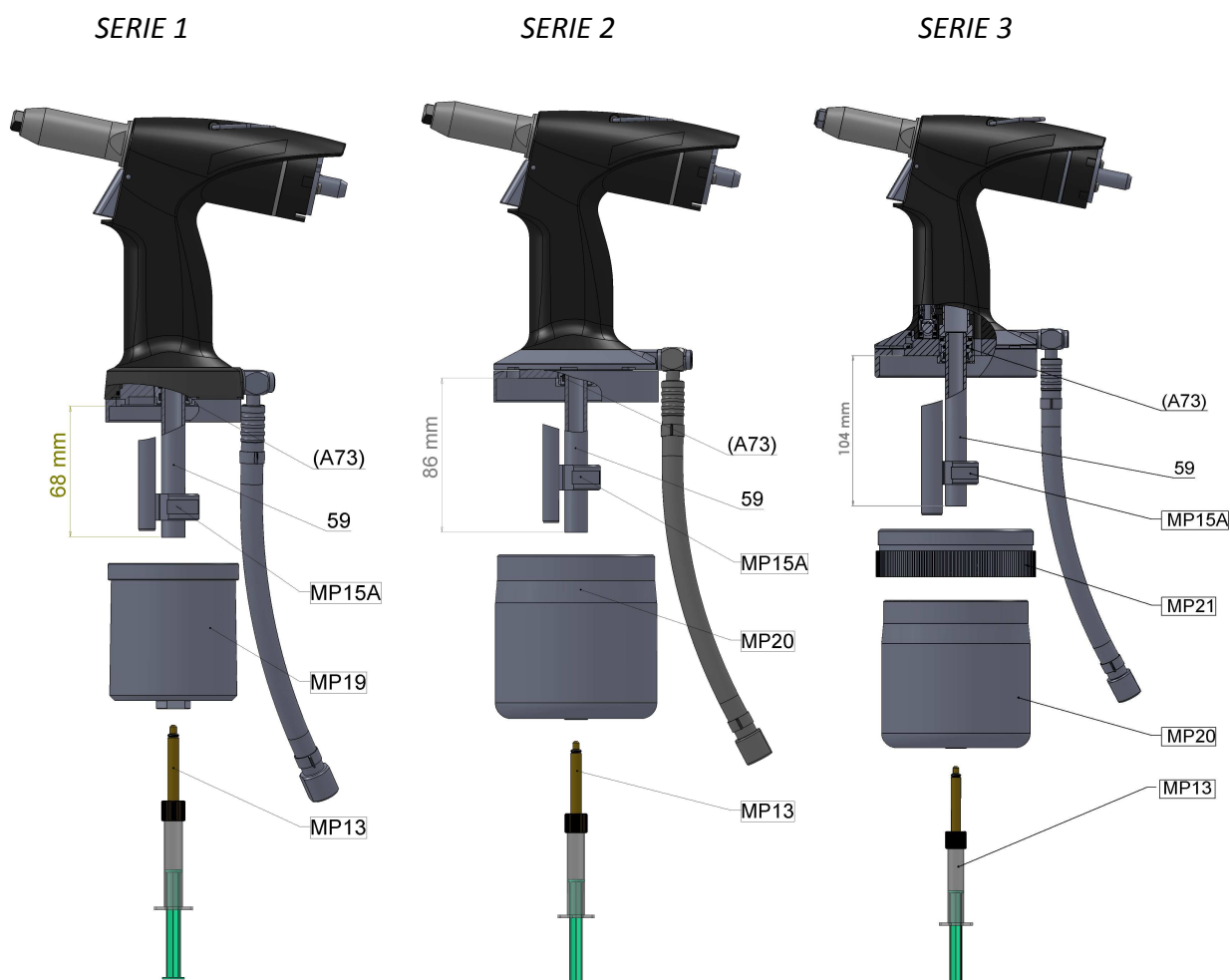

Assembly:

Pour hydraulic oil KERNITE IGM ISO 32 in to pos. A73 up to the second sealing in pos. A73. Lubricate outer surface of pos. 59 with LUKOSAN paste., put pos. 59 on pos. A73 to the distance different according to tools type (see pictures), screw on MP19, MP20 or MP20+MP21 to the stop, screw MP13, filled with hydraulic oil, on pos. 59. Connect CA, slowly and repeatedly press and release piston MP13 as long as air bubbles leak from MP13. MP13 has to always be filled with hydraulic oil, if not, fill the oil in. After pouring hydraulic oil in to hydraulic system of the riveting tool, disconnect CA and screw off pos. MP13 and MP19, MP20 or MP20+MP21. Put pos. 60 on pos. 61 and screw it on pos. 59 with imbus key nr. 3. Put MP15A on pos. 59, then press MP15A with wrench and tighten pos. 61 with imbus nr. 3. Remove MP15A.

Step 5

Disassembly:

Put MP11 into locks of pos. 79, slightly divert pos. 66 from MP11 (there is a possibility of damaging the surface of pos. 66) and screw pos. 79 out.

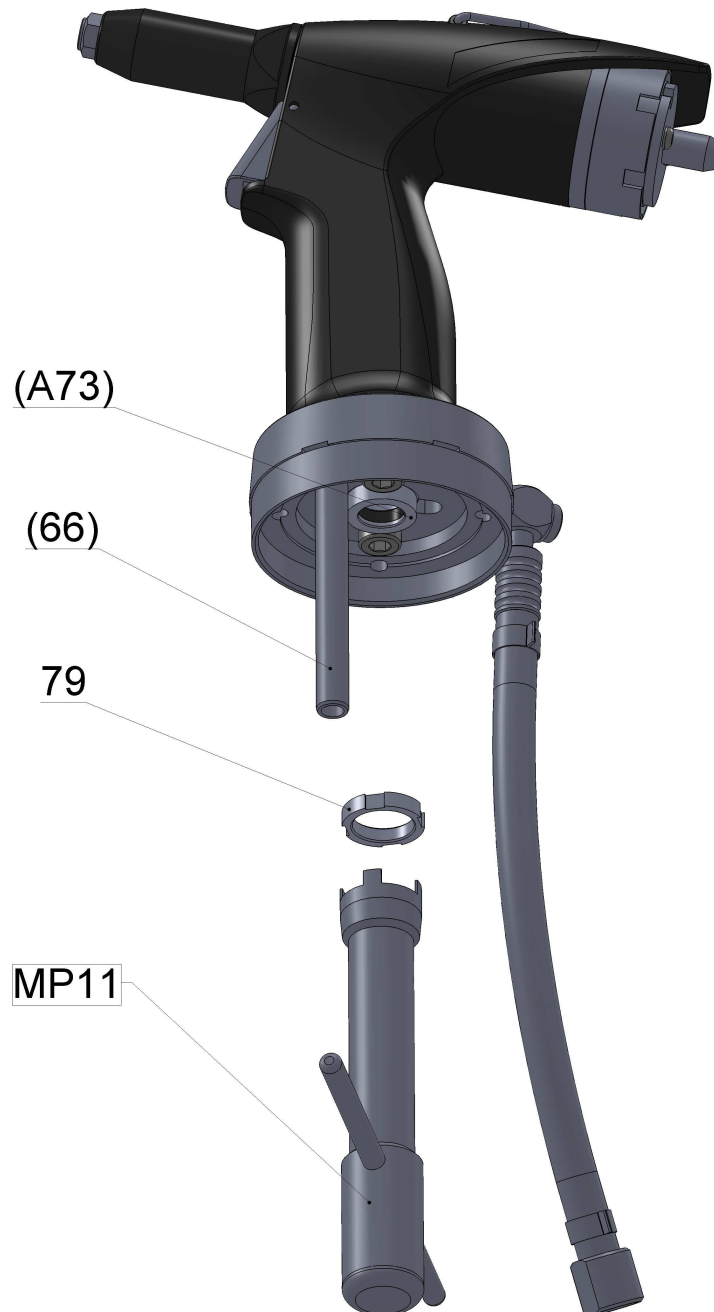

Assembly:

Screw pos. 79 on to the thread of pos. A73, put MP11 on the locks of pos. 79, slightly divert pos. 66 from MP11 (there is a possibility of damaging the surface of pos. 66), tighten pos. 79.

Step 6

Disassembly:

Screw pos. 49 (2x) out with imbus key nr. 5 (tool SERIE 1, SERIE 2) or imbus key nr. 7 (tool serie only), put out pos. 54 with pos. 66, 68, 69 and pos. A75 with pos. 67. Put pos. 66 with pos. 68 out., take pos. 69 out with MP32, be careful and do not damage recess in pos. 54. Put pos. 54 out of pos. A75.

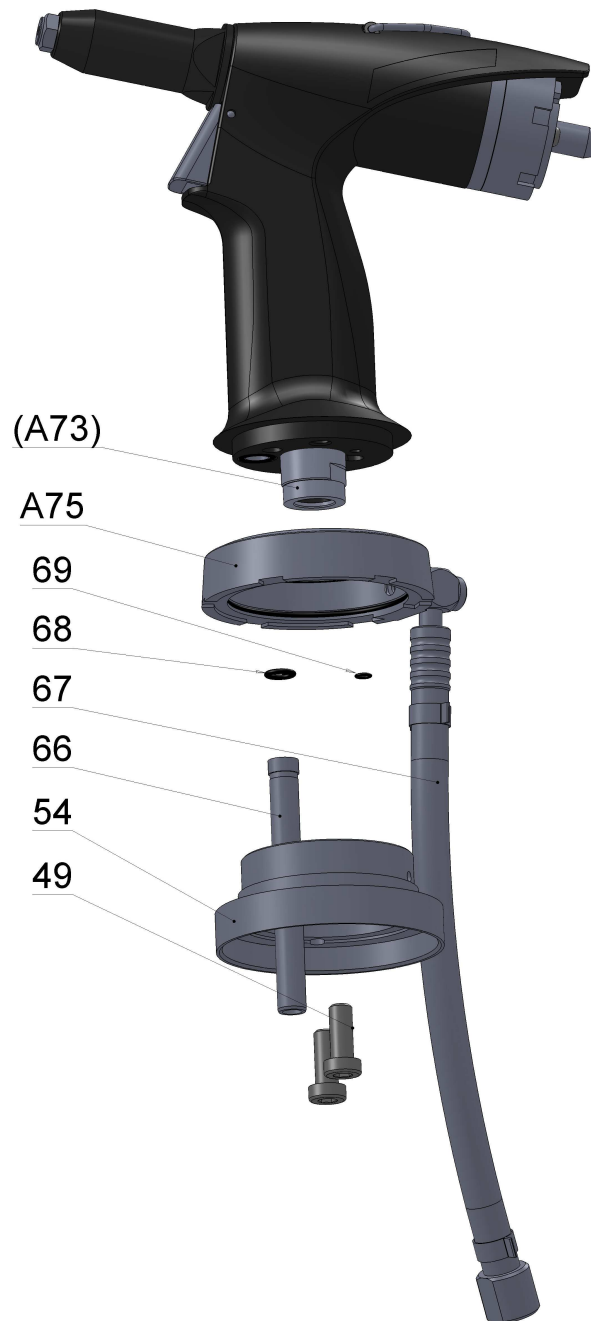

Assembly:

Check the positions of sealings on pos. 51 and pos. 52 (see Step 21). Put on pos. 54 in to pos. A75 with pos. 67. Insert pos. 66 to pos. 54, lubricate recess in pos. 54 and insert pos. 68 and pos. 69. Screw on pos. 49 (2x) and tighten with imbus key nr. 5 (tools SERIE 1 and SERIE 2) or imbus key nr. 7 (tools SERIE 3 only).

Step 7

Disassembly:

Put the blow gun on the outlet (see the detail) and release a small amount of CA, pos. A39, A40, 46 and A41 will blow out of pos. A70 due to the CA, it is necessary to catch it (e.g. with a cloth).



Assembly:

Insert pos. A39 into pos. A40 and insert this complet into pos. A70. Insert pos. 46 into pos. A40, put on pos. A41 and press to the stop to pos. A70.

! Do not lubricate pos. 46!

Step 8

Disassembly:

Loosen pos. A73 with MP33 key, screw out and take out of pos. A70.

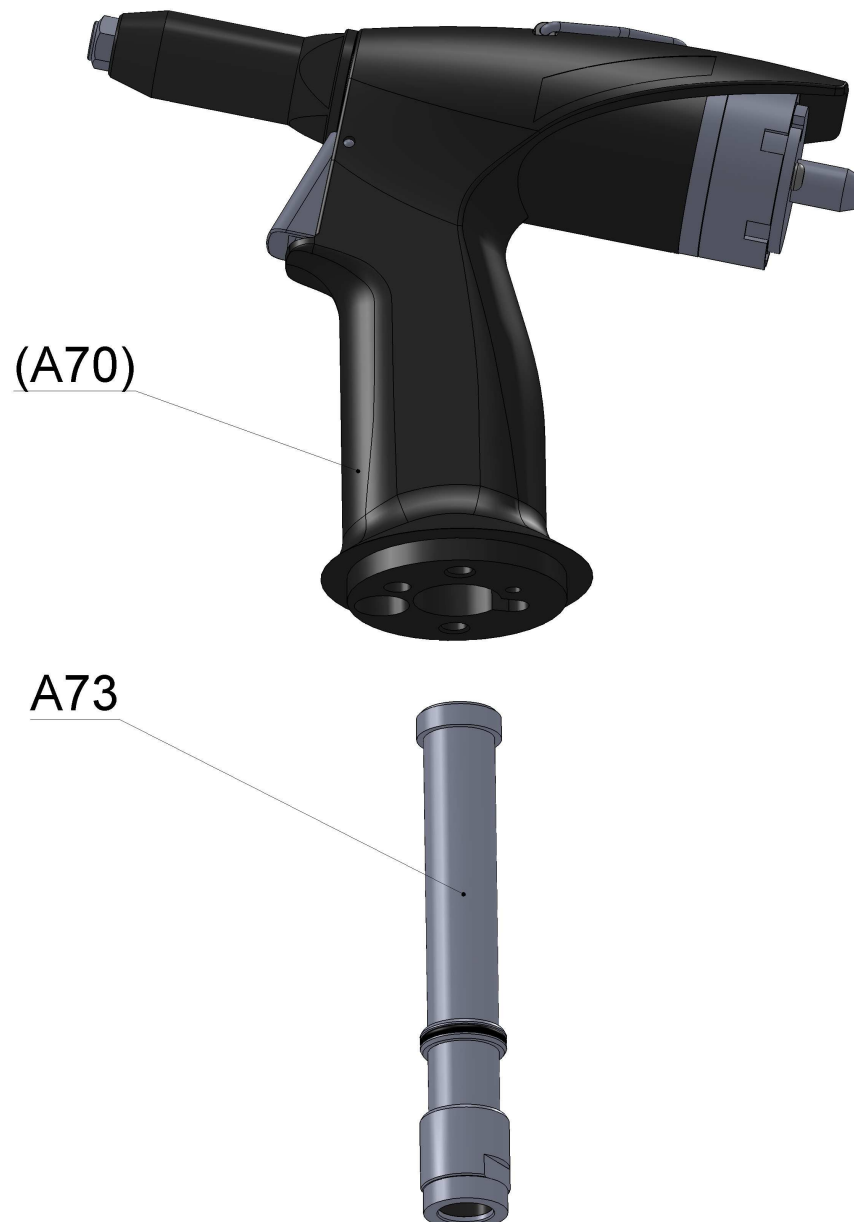

Assembly:

Put pos. A73 on pos. A70, screw on and tighten with MP33 key.

! Check the right position of the sealing!

Step 9

Disassembly:

Screw pos. 1 out of pos. 9 with a wrench 12, screw pos. 9 and pos. 10 out of pos. A70 with a wrench 23. Take pos. 10 out of pos. 9 with a help of MP32.

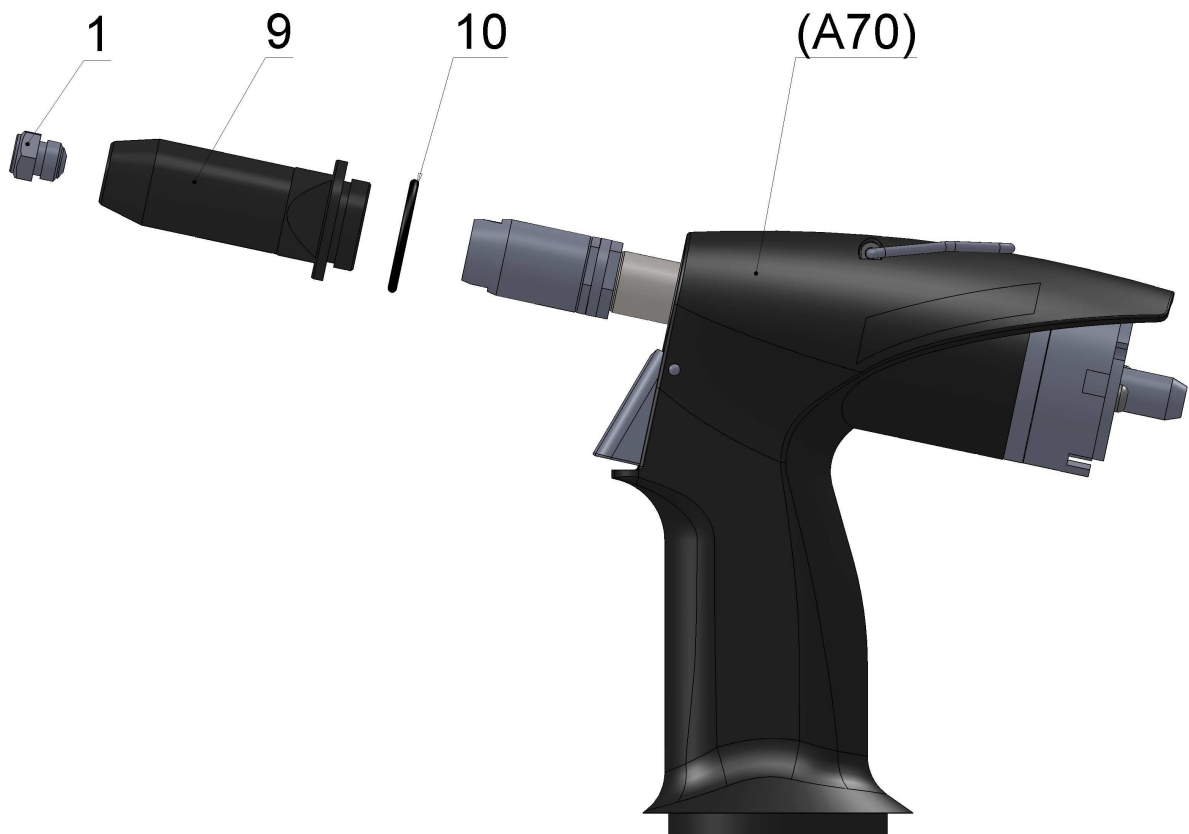

Assembly:

Put pos. 10 on the slot of pos. 9. Screw pos. 9 and pos. 10 on pos. A70 with a wrench 23 and tighten. Screw pos. 1 on pos. 9 and tighten with a wrench 12.

! Pos. 10 has to be in the correct position when tightening pos. 9 to pos. A70 !

Step 10

Disassembly:

Take pos. 5 out of pos. 6 with the help of MP32. Put wrench 17 on pos. 3, put wrench 17 on pos. 6, loosen and screw pos. 3 together with pos. 2 out of pos. A71. Take pos. 2 out of pos. 3.

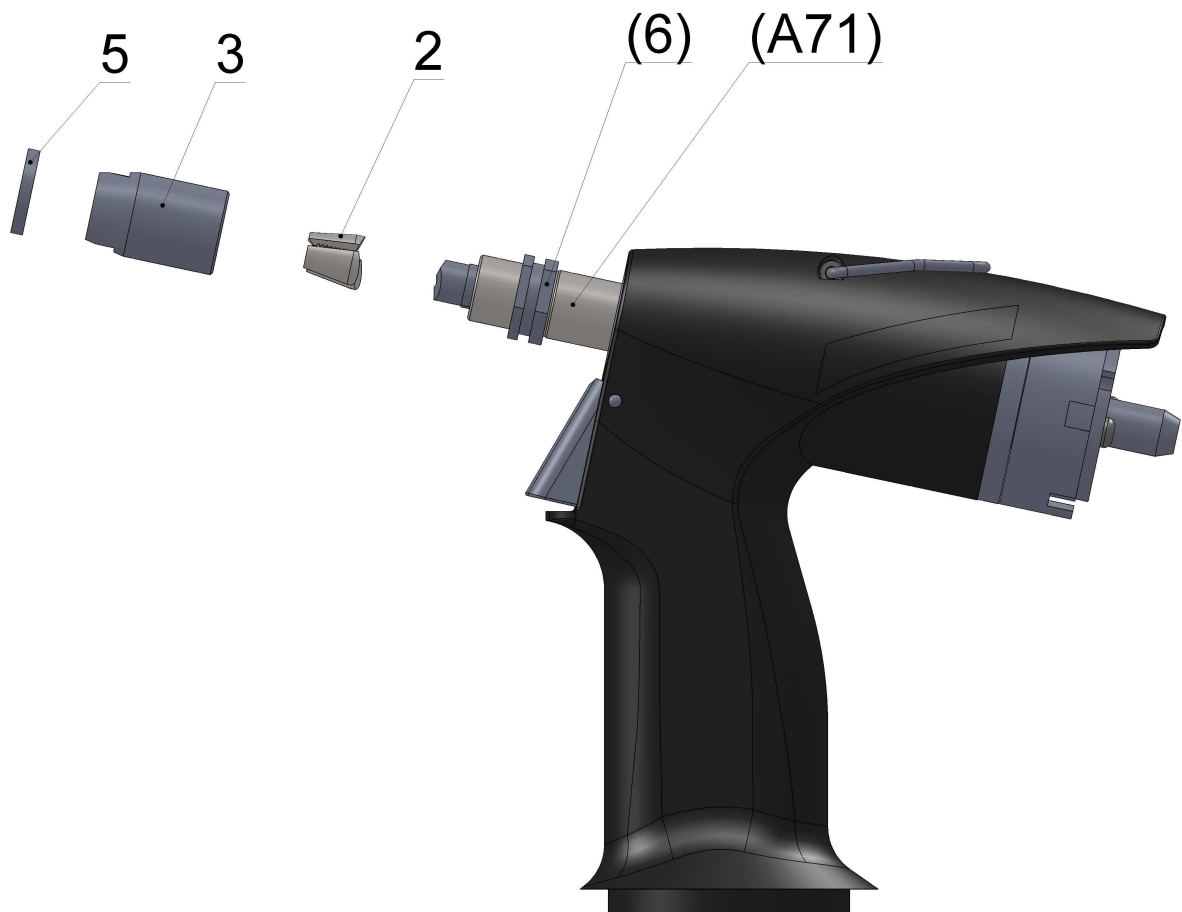

Assembly:

Slightly lubricate pos. 2 and insert it into pos. 3. Screw pos. 3 together with pos. 2 on pos. A71. Put a wrench 17 on pos. 3, put a wrench 17 on pos. 6 and tighten them. Put pos 5. on pos. 6.

Step 11

Disassembly:

Take pos. 8 out of pos. A71.

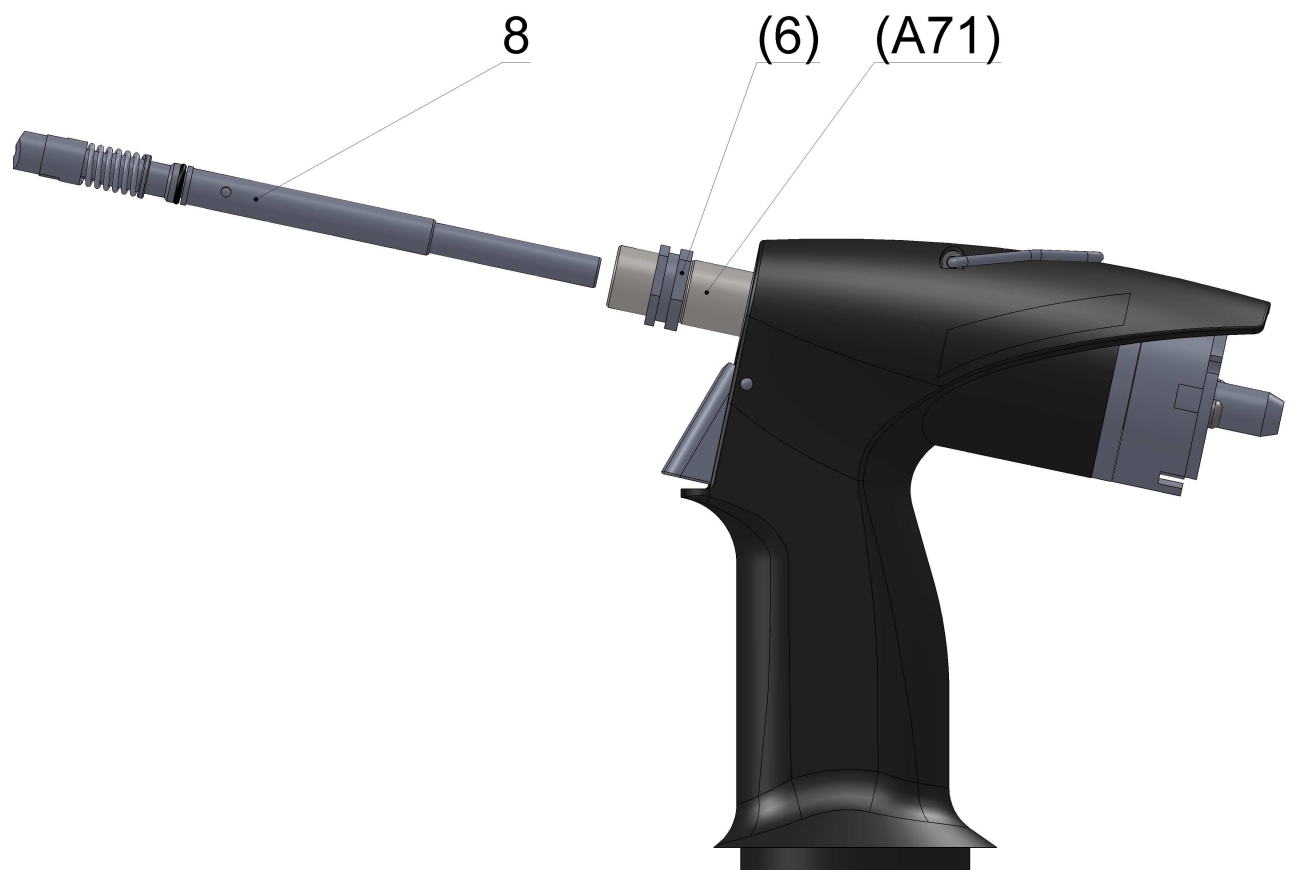

Assembly:

Insert pos. 8 into pos. A71.

Step 12

Disassembly:

Screw pos. 6 out of pos. A71.

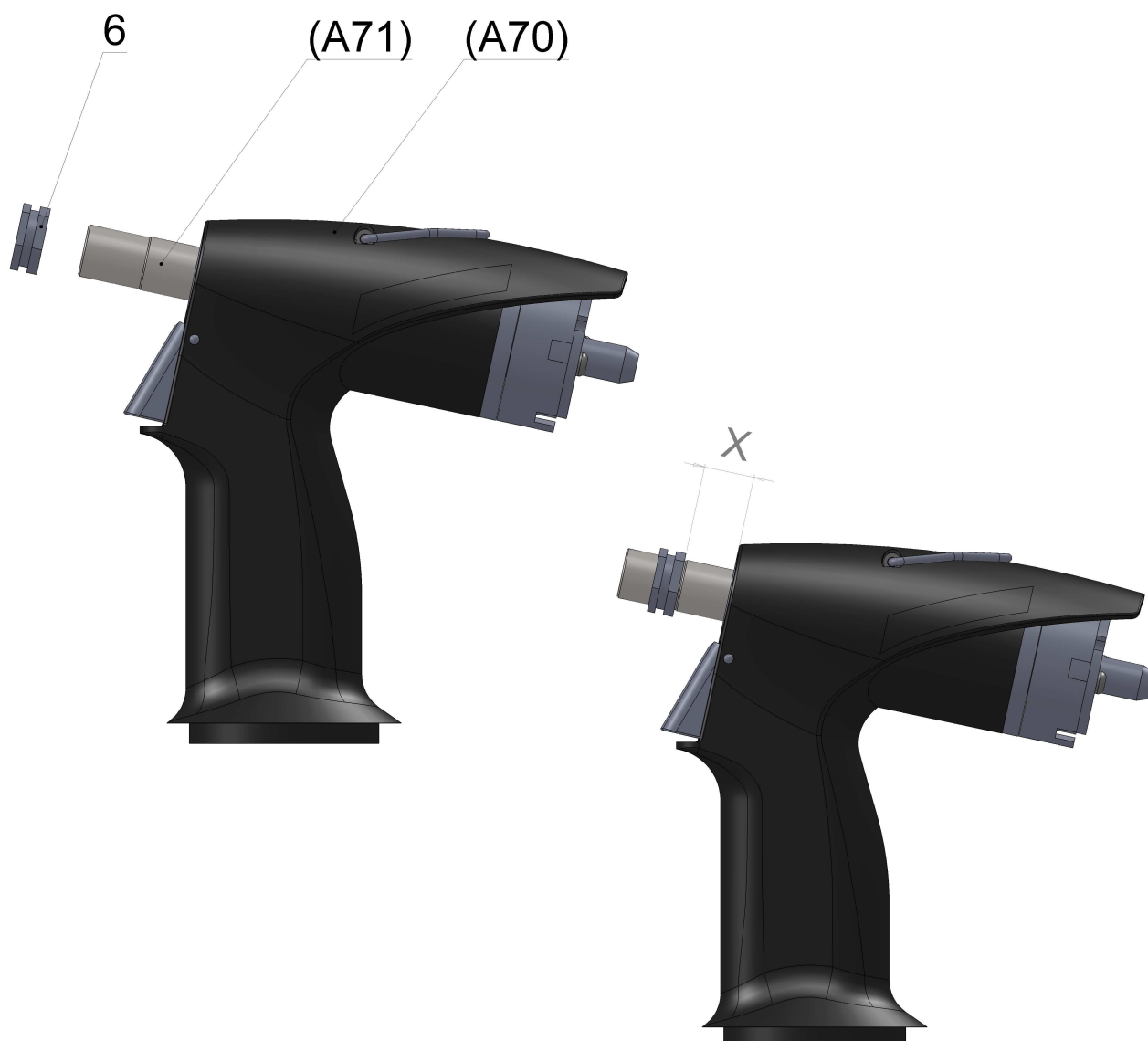

	<i>SERIE 1</i>	<i>SERIE 2</i>	<i>SERIE 3</i>
x (mm)	15,5±0,2	15,5±0,2	19,5±0,2

Assembly:

Screw pos. 6 on and set the distance according to the table.

Step 13

Disassembly:

Hold pos. 31 and screw pos. 30 (2x) out with imbus key 2,5, move slightly with pos. 31 off the pos. 26 so that s. 34 are not sprung pos. 35. Take out pos. 28, pos. 34 and pos. 35. Put out pos. 26 together with pos. 81. Put pos. 81 out of pos. 26 with the help of MP32. Put pos. A72 out of pos. 25 with the help of MP32.

! Beware of possible shooting up of pos. 34 !

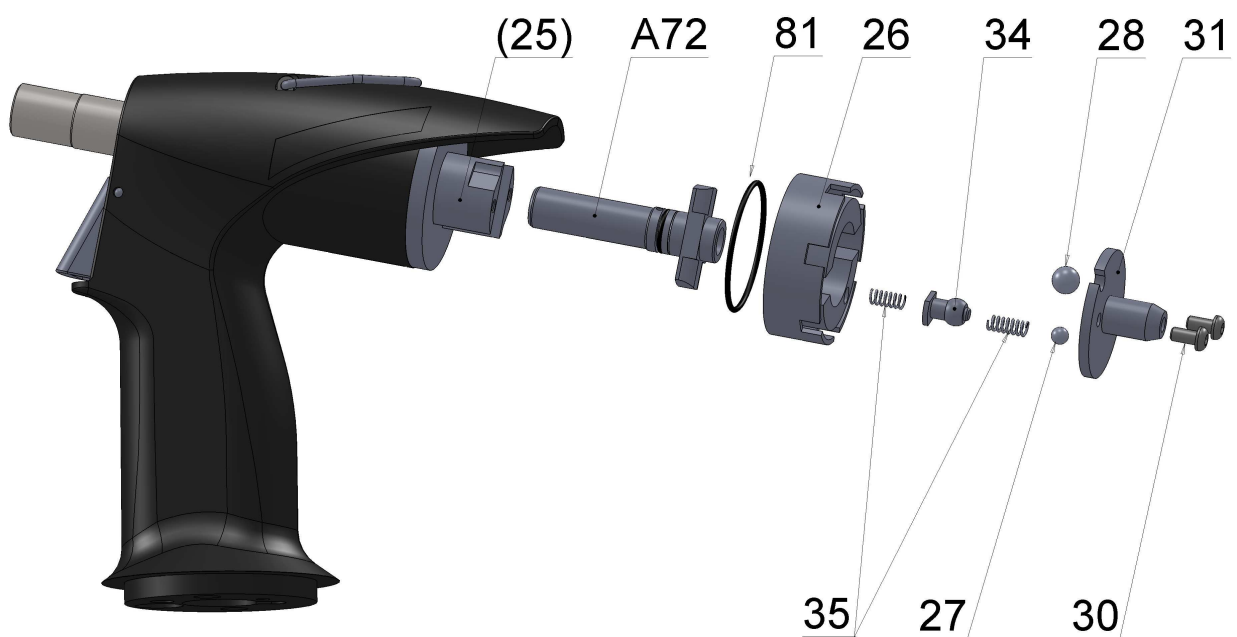

Assembly:

Insert pos. A72 into pos. 25 to the stop. Put pos. 81 on the slot of pos. 26, put pos. 26 together with pos. 81 on pos. 25. Insert pos. 35 and pos. 34, pos. 28 into the recesses in pos. 26 (see the picture). Apply pos. 31 to spring-loaded pos. 34. Push pos. 31 to pos. 26, position and screw on pos. 30 (2x). Check accuracy of the assembly in the chapter 3.

! Do not lubricate pos. 81 !

Step 14

Disassembly:

Screw pos. 25 out of pos. A70 with the help of MP12, take pos. 24 out of pos. 25 with the help of MP32.

Tool SERIE 3 only - Take pos. 82 and pos. 24 out of pos. A70.

SERIE 1, SERIE 2

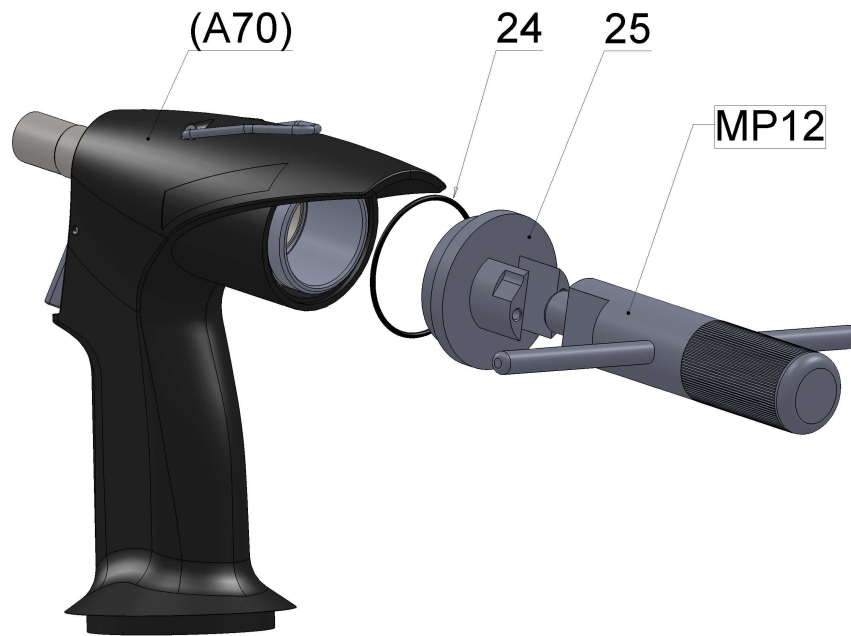

SERIE 3

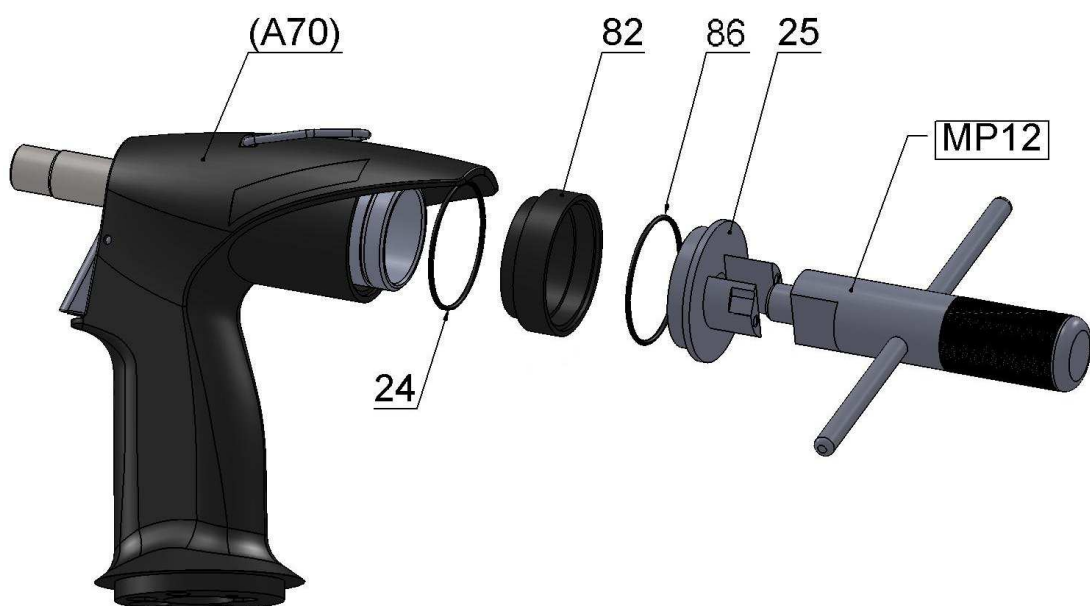

Assembly:

Tool SERIE 3 only - Put pos. 24 on pos. 82 and put into pos. A70.

Put pos. 24 on pos. 25, screw pos. 25 to pos. A70 and tighten with MP12.

Step 15

Disassembly:

Take pos. A71 out of pos. A70 in the direction of the dart.

!Be careful and do not damage the sealing of pos. A70!

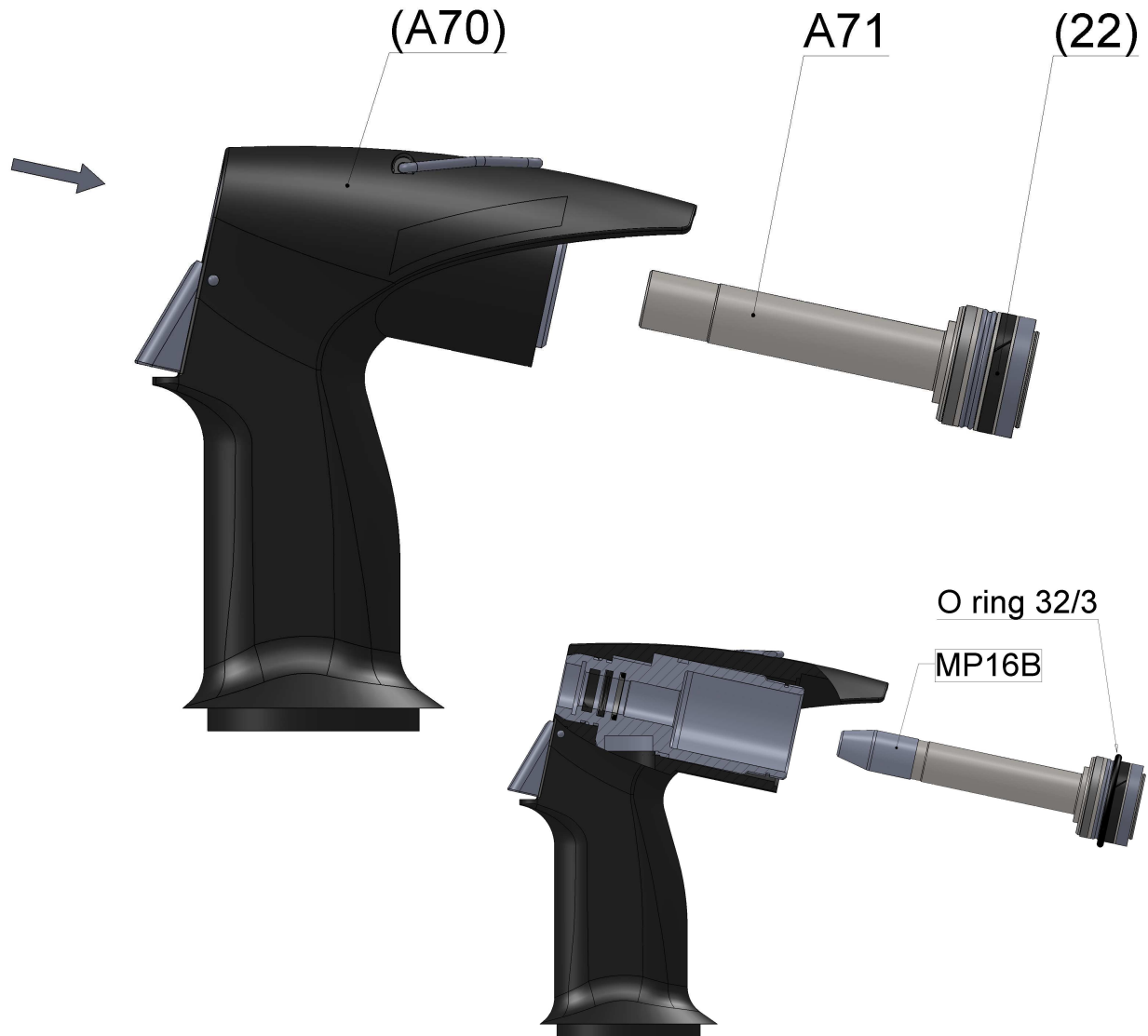

Assembly:

Put MP16B on the thread of pos. A71. Lubricate external surface of MP16B and pos. A71, inner surface of pos. A70 and related sealings of pos. A71 and pos. A70 with silicon paste LUKOSAN. Secure pos. 22 in pos. A71 with O-ring 32/3 (see the picture), then insert pos. A71 into pos. A70 to the stop, pos. A71 in pos. A70 has to slide.

!O ring 32/3 will loosen while inserting pos. A71 to pos. A70, it is not a part of the riveting tool!

Step 16

Disassembly:

Place a pin cca 2,8 mm in diametre to the pos. 76 and knock out with a hammer from pos. A70, put out pos. 74 together with pos. 77 (2x) and pos. 78. Take pos. 77 (2x) together with pos. 78 out of pos. 74.



Assembly:

Put pos. 76 partly on pos. 74. From the inner side of pos. 74 put on to pos. 76, pos. 77 and pos. 78. Move pos. 76 towards the opposed side of pos. 74 - cca 3 mm in distance. Push pos. 78 and insert pos. 77. Push pos. 76 through opposed side of pos. 74 and then take it out of pos. 74. Put set (pos. 74 with pos. 77 (2x) and pos. 78) into the recess in pos. A70, beat pos. 76 into A70 with a hammer and pin cca 2,8 mm in diametre, so that it is placed symmetrically in pos. A70. Put coloured warranty plug on pos. 76.

Step 17

Disassembly:

Put MP10 to the locks of pos. A46 and screw out together with pos. 73 of pos. A70, take pos. 73 out of pos. A46.

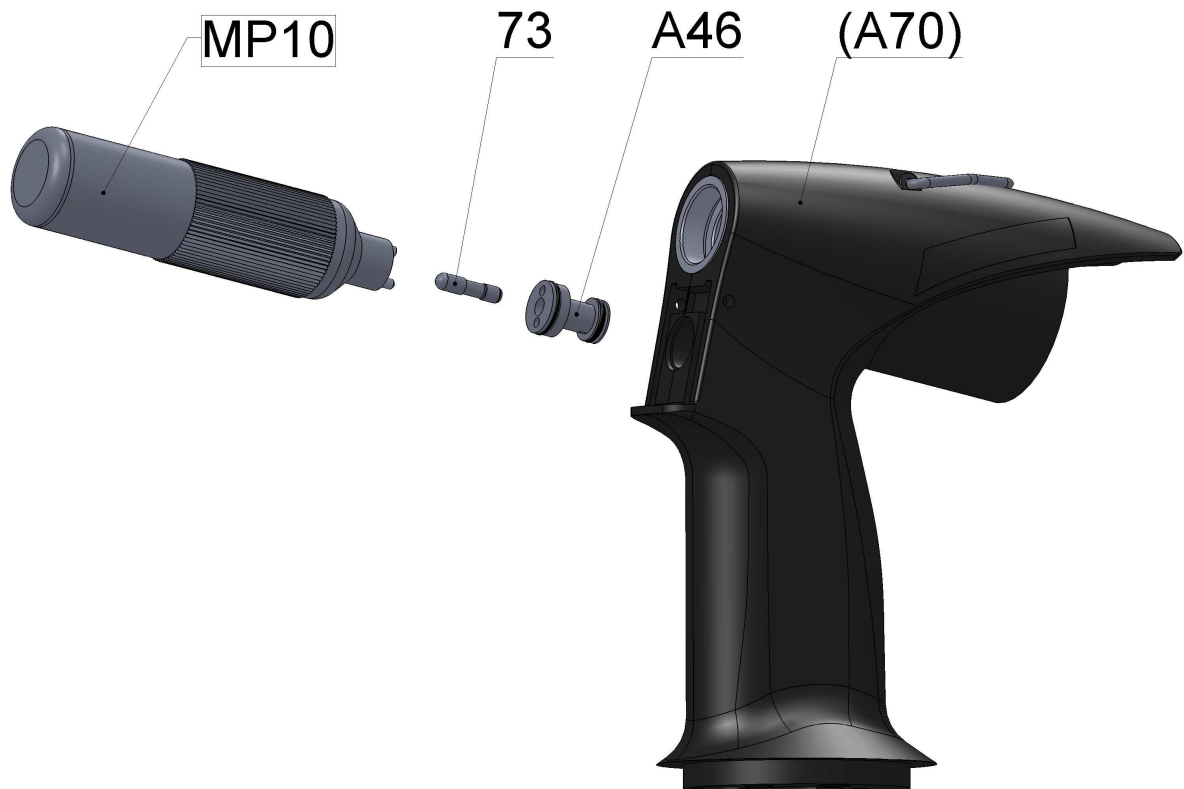

Assembly:

Screw pos. A46 on pos. 70 with the help of MP10, so that the front sides of both positions were neck and neck, then insert pos. 73 to pos. A46

Step 18

Disassembly:

Take pos. 16 out of pos. A70.

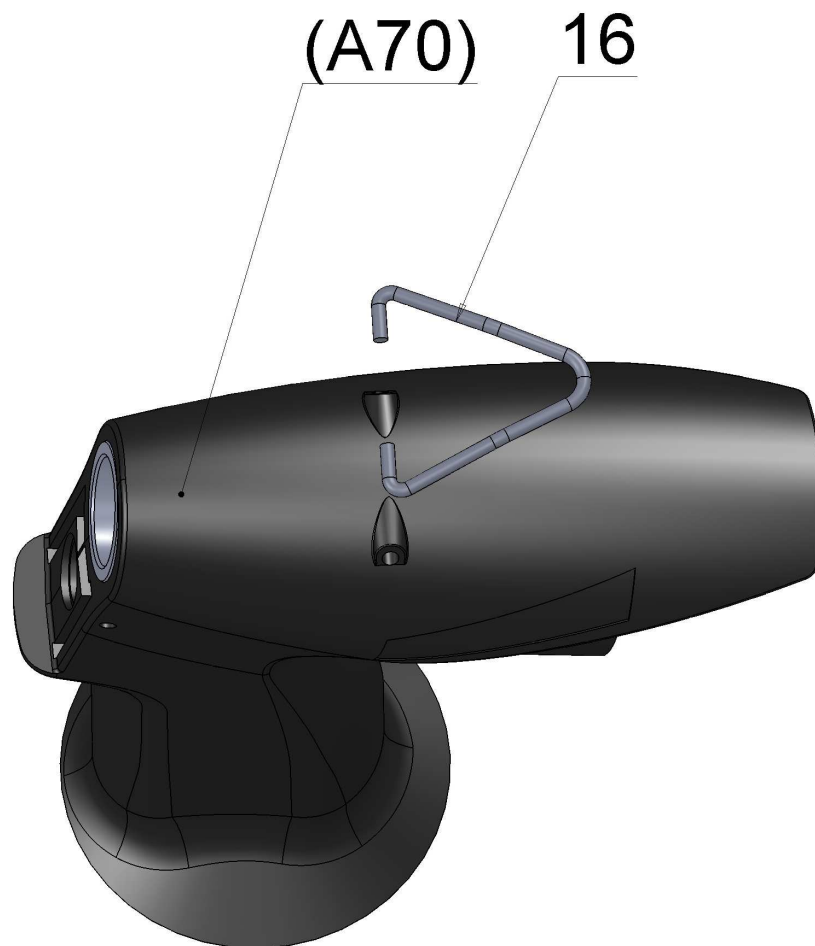

Assembly:

Put pos. 16 on pos. A70.

7. Instructions for assembling and disassembling of sub-assemblies

– steps 19-26

Step 19 – pos. A74

Disassembly:

Tool SERIE 1 and SERIE 2 - Take pos. 64 out of pos. 62, take pos. 63 out of pos. 62 with the help of MP32.

Tool serie only - Take pos. 64 out of pos. 62, take pos. 63 and pos. 58 out of pos. 62 with the help of MP32.

Be careful and do not damage recess in pos. 62!

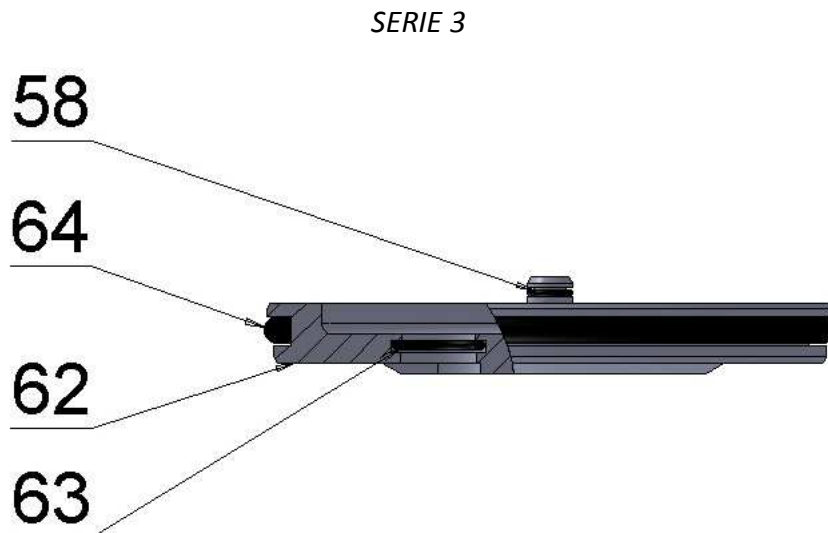
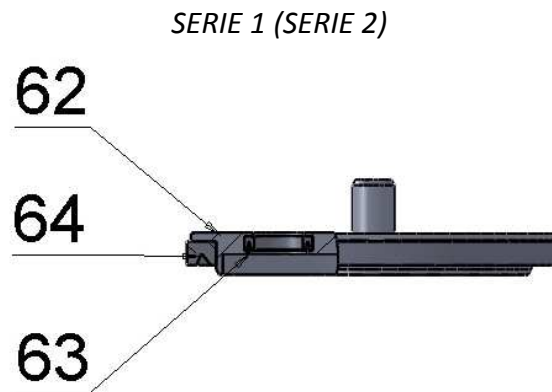

Assembly:

Tool SERIE 1 and SERIE 2 - Insert by hand pos. 63 to pos. 62 so that the pos. 63 does not twist off. Put pos. 64 to pos. 62.

Tool SERIE 3 only - Insert by hand pos. 63 to pos. 62 so that the pos. 63 does not twist off. Put pos. 58 on pos. 62. Put pos. 64 to pos. 62.

Step 20 – pos. A73, tool SERIE 1 only

Disassembly:

Take pos. 39 and pos. 41 out of pos. 4001 with the help of MP32. Take pos. 4008, pos. 4007, pos. 4005 and pos. 4006 out of pos. 4001 with the help of MP29. Releasing pos. 4008, pos. 4007, pos. 4005 and pos. 4006 with the help of MP29 leads to their damage or destruction and it is necessary to replace them!

Be careful and do not damage recesses in pos. 4001!

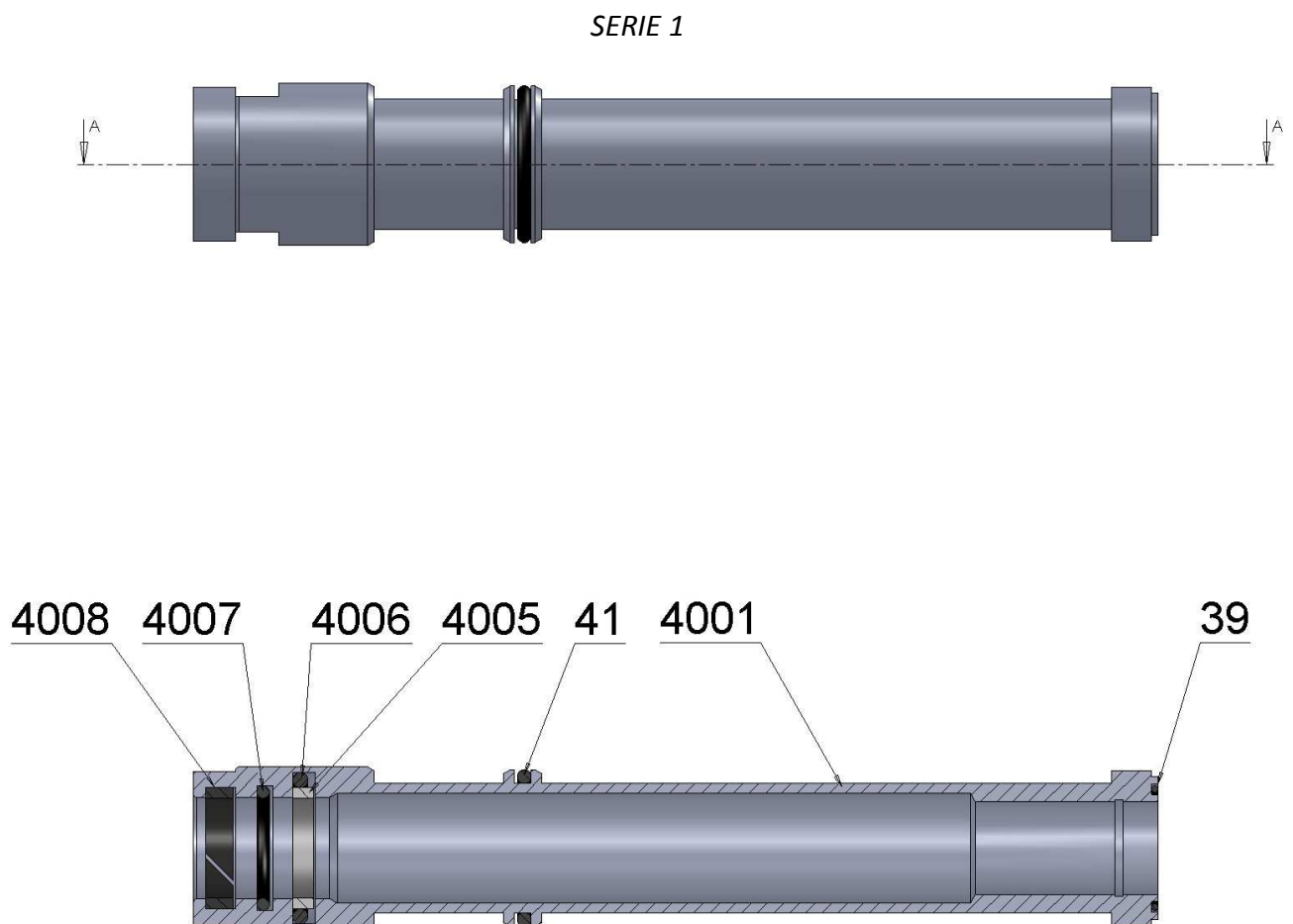

Assembly:

Put pos. 4008, pos. 4007, pos. 4006 and pos. 4005 into pos. 4001 with the help of MP04ABC. Put pos. 41 on pos. 4001, be careful while putting it on and do not damage pos. 41 with a thread on pos. 4001. Lubricate the recess in pos. 4001 and put it on pos. 39.

Step 20 – pos. A73, tool SERIE 2 and SERIE 3

Disassembly:

Take pos. 4010 with pos. 39 and pos. 4011, pos. 4012 and pos. 4009 out of pos. 4001 with the help of a rod. Take pos. 39 and pos. 4011 out of pos. 4010 with the help of MP32. Take pos. 41 out of pos. 4001 with the help of MP32. Take pos. 4008, pos. 4007, pos. 4005 and pos. 4006 out of pos. 4001 with the help of MP29. Releasing pos. 4008, pos. 4007, pos. 4005 and pos. 4006 with the help of MP29 leads to their damage or destruction and it is necessary to replace them! Be careful and do not damage recesses in pos. 4001 and pos. 4010!

SERIE 2, SERIE 3

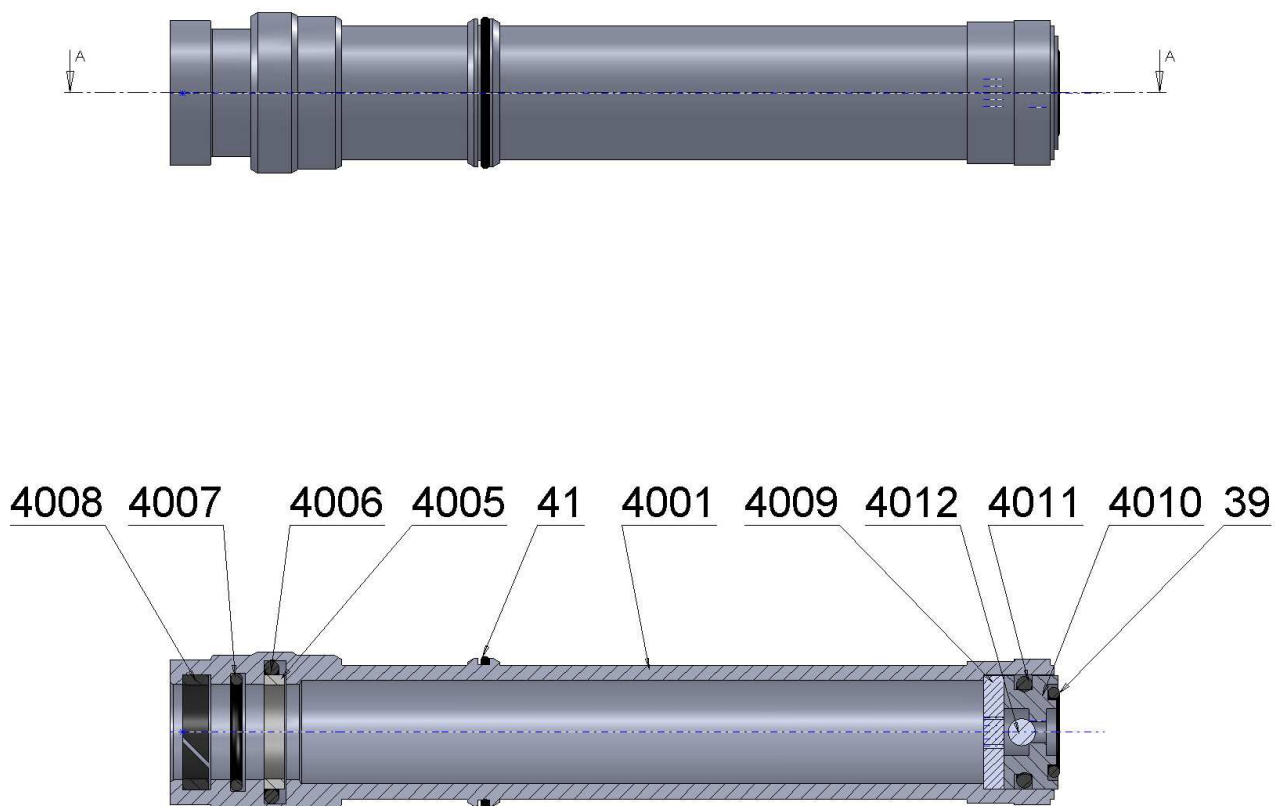

Assembly:

Put pos. 4008, pos. 4007, pos. 4006 and pos. 4005 into pos. 4001 with the help of MP04ABC. Put pos. 41 on pos. 4001, be careful while putting it on and do not damage pos. 41 with a thread on pos. 4001. Put pos. 4011 on pos. 4010. Lubricate the front recess in pos. 4010 and put pos. 39 on pos. 4010. Put pos. 4009, pos. 4012, pos. 4010 with pos. 39 and pos. 4011 into pos. 4001 according the picture.

Step 21 – pos. A75 and pos. 67

Disassembly:

Put pos. 51 and pos. 52 out of pos. 53 with MP32. Screw pos. A43 with pos. A44 and pos. 6705 out of pos. 53 with imbus key nr. 5. Disassembly pos. 6705 with circlip pliers, put pos. A44 out of pos. A43.

Be careful and do not damage recesses in pos. 53!

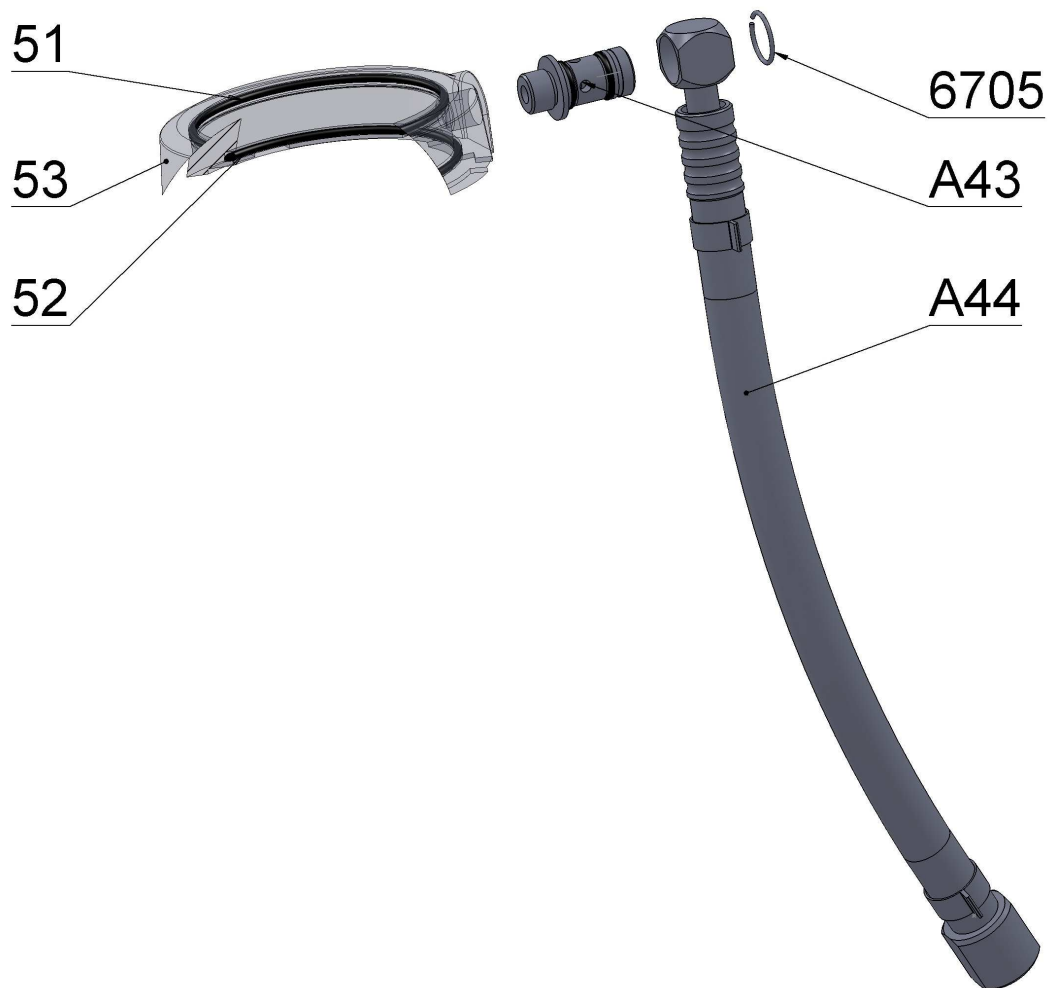

Assembly:

Put pos. A44 on pos. A43 and secure pos. 6705 with circlip pliers. Screw pos. A43 with pos. A44 and pos. 6705 on pos. 53 with imbus key nr. 5. Insert pos. 51 and pos. 52 to recesses pos. 53.

Step 22 – pos. A71

Disassembly:

Take pos. 18, pos. 19, pos. 20, pos. 22 and pos. 23 out of pos. 17 with the help of MP32, do not damage recesses in pos. 17. Take pos. 21 out of pos. 17 with the help of MP32.

Be careful and do not damage recesses in pos. 17!

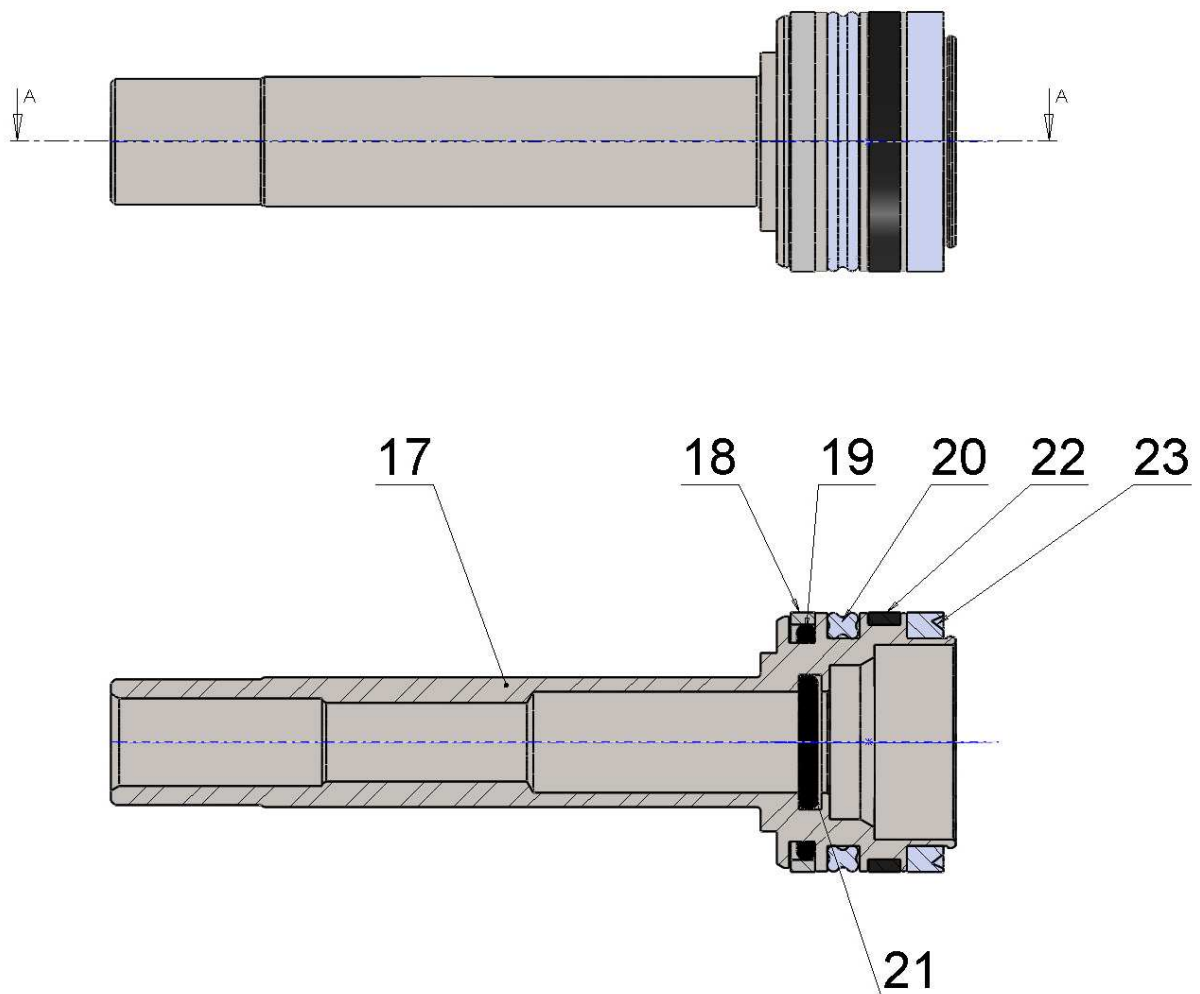

Assembly:

Insert pos. 21 into pos. 17. Put pos. 20 on pos. 17 with the help of MP02. Put pos. 19, pos. 22 and pos. 23 on pos. 17. Put pos. 18 on pos. 17 with the help of MP31.

Step 23 – pos. 8

Disassembly:

Take pos. 802 out of pos. 801 with the help of MP32, do not damage the recess in pos. 801. Put a wrench 7 on pos. 801 (necessary press pos. 803), put a wrench 10 on pos. 804 and loosen. Take both wrenches out, screw pos. 804 out and take pos. 803 and pos. 805 out.

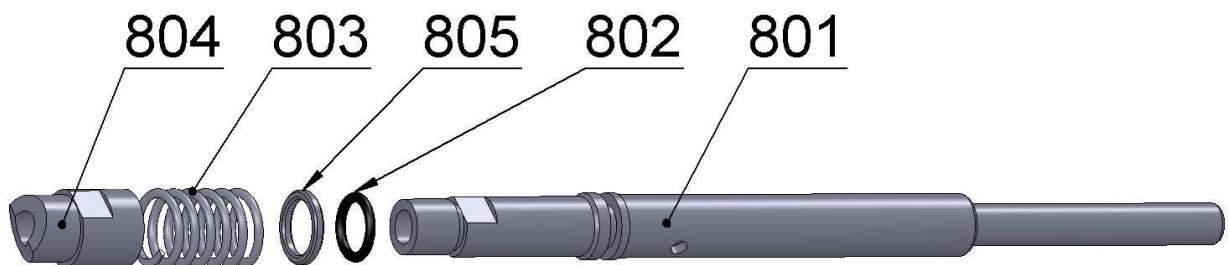

Assembly:

Put pos. 802 on pos. 801. Put pos. 805 and pos. 803, put several drops of glue Loctite 246 on the thread of pos. 801 and screw pos. 804 on. Put a wrench 7 on pos. 801 (necessary press pos. 803), put a wrench 10 on pos. 804 and tighten them. Take both wrenches out.

Step 24 – pos. A72

Disassembly:

Take pos. 36 out of pos. 37 with the help of MP32. Take pos. 38 and pos. 33 out of pos. 37 with the help of MP29. Releasing pos. 38 and pos. 33 with the help of MP29 leads to its damage or destruction and it is necessary to replace it!

Be careful and do not damage recesses in pos. 37!

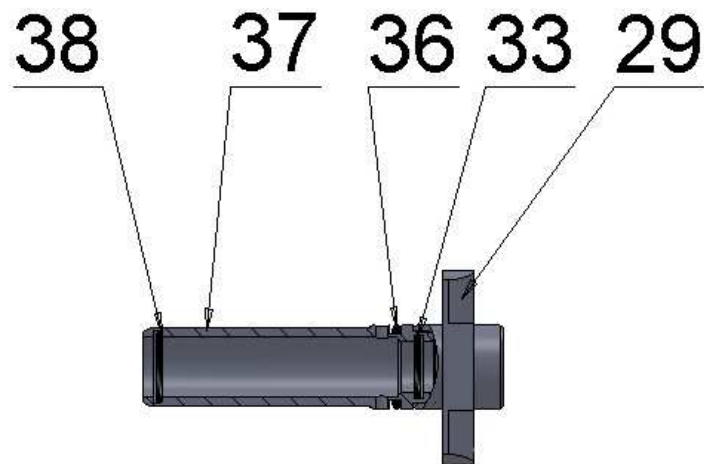

Assembly:

Put pos. 33 and pos. 38 into pos. 37 with the help of MP32. Put pos. 36 on pos. 37.

Step 25 – pos. A39, pos. A40, pos. A41 and pos. 46

Disassembly:

Take pos. 46 and pos. A39 out of pos. A40. Take pos. 43 out of pos. 42 with the help of MP32. 42. Take pos. 44 (2x) out of pos. 45 with the help of MP32. Take pos. 44 and pos. 48 out of pos. 47 with the help of MP32.

Be careful and do not damage recesses in pos. 42 and pos. 45!

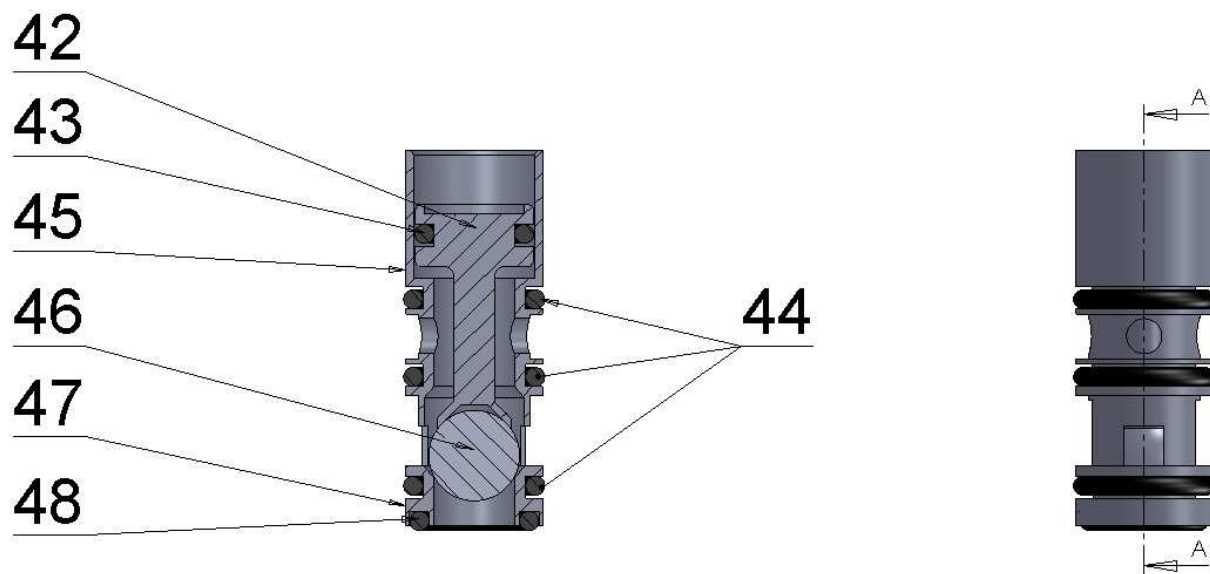

Assembly:

Put pos. 43 on pos. 42. Put pos. 44 (2x) on pos. 45 with the help of MP05. Put pos. 44 and pos. 48 on pos. 47. Put pos. 46 and pos. A39 into pos. A40.

Step 26 – pos. A46

Disassembly:

Take pos. 70 and pos. 75 out of pos. 71 with the help of MP32. Take pos. 72 (2x) out of pos. 71 with the help of MP29. Releasing pos. 72 (2x) with the help of MP29 leads to its damage or destruction and it is necessary to replace it!

Be careful and do not damage recesses in pos. 71!

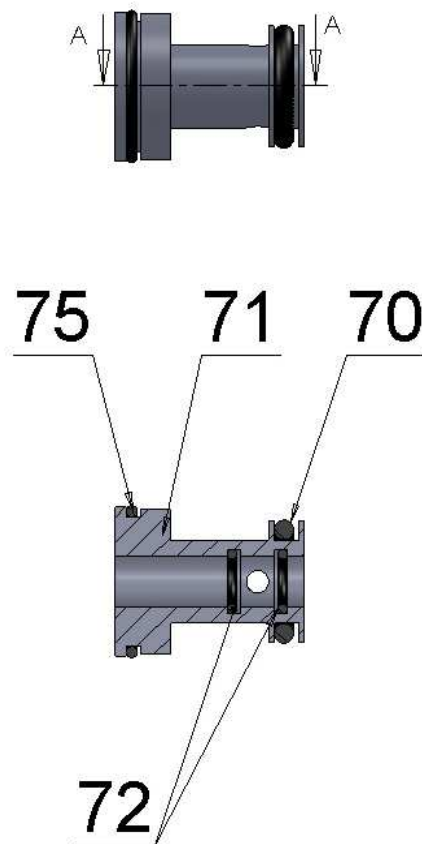

Assembly:

Put pos. 72 (2x) into pos. 71. Put pos. 75 and pos. 70 on pos. 71.

Step 27 – pos. A70

Disassembly:

Take pos. 12, pos. 13, pos. 14 and pos. 15 out of pos. 11 with the help of MP29. Releasing pos. 12, pos. 13, pos. 14 and pos. 15 with the help of MP29 leads to their damage or destruction and it is necessary to replace them!

Be careful and do not damage recesses in pos. 11!



Assembly:

Put pos. 12 into pos. 11 with the help of MP09A and MP09D. Put pos. 13 into pos. 11 with the help of MP09B and MP09D. Put pos. 15 and pos. 14 into pos. 11 with the help of MP09C and MP09D (tool SERIE 1, SERIE 2 only).

Put pos. 12 into pos. 11 with the help of MP09A. Put pos. 13 into pos. 11 with the help of MP09B. Put pos. 15 and pos. 14 into pos. 11 with the help of MP09C (tool SERIE 3 only).

8. List of defects of riveting tool

- D1 it is impossible to insert BR into the riveting tool or the nail does not loosen after tearing
- D2 suction does not turn on with pos. 32
- D3 suction does not turn off with pos. 32
- D4 suction does not turn off with pos. 74 (refers only to riveting tools equipped with lock function)
- D5 does not suck (or does not suck enough) or shoots BR forwards
- D6 does not collect the nail of BR (but the tool works properly)
- D7 CA distribution
- D8 CA leaks in pos. 74 (pos. 74 is not pressed)
- D9 CA leaks in pos. 74 (pos. 74 is pressed)
- D10 CA leaks in pos. A75+67(pos. 74 is not pressed)
- D11 CA leaks in pos. A75+67 (pos. 74 is pressed)
- D12 CA leaks between pos. A70 and 25
- D13 does not tear BR in one working stroke (oil leaks)
- D14 skim in the oil

9. Description of defects and their remedies:

<i>Defect</i>	<i>Operation</i>	<i>Step</i>	<i>Change of pos.</i>
D1	check tightening of threads pos.1 and 9	9	
	disassembly pos. 1, check conic surface and patency of the outlet	9	1
	disassembly pos. 9	9	
	check "cleanness" of pos.. 2,3,5,9, pos. 9 has to slide on pos. 3,5		9
	disassembly pos.3,2,(4),5	10	
	check functional surfaces pos. 2,3,(4),5		2,3,(4),5
	disassembly pos. 8	11	
	check functional surface and patency of outlets (axial and 2x for CA)		8
	check position of pos. A71 from the front of pos. A70	12	
	YES		
	adjust position of pos.6 from the front of pos. A70	12	
	NO		
	further see D 14		
D2	everything as in D1		
	everything is OK		
	disassembly pos. 32 and check the wear	1	32
	disassembly pos. 30 (2x),31,27,28,34,35 (2x),26,A72	13	
	check the wear and "cleanness" pos. 26,31,34,A72 (pressing-on)		26,31,34,A72
D3	disassembly pos. 32	1	
	disassembly pos. 30 (2x),31,27,28,34,35 (2x),26,A72	13	
	check the wear pos. 26		26
	check external surface pos. A72, sealings and pressing-on		A72
	OK		
	disassembly pos.. 25	14	
	change pos. 21 in pos. A71 (without any further disassembly)	22	21
D4	disassembly pos. 76,74,77,78	16	
	check functional surfaces pos. 74		74
	check relative positions pos. A46 and A70	17	
	disassembly pos. A46,73	17	
	check functional surfaces pos. 73		73
	NO		
	further see D3		
D5	everything as in D1		
	everything is OK		
	check pos. 8 : pos. 802, patency of outlets (axial and 2x for CA)		
	external surfaces, pressing-on	(23)	8,(802)
	disassembly pos. 32	1	
	check patency of outlets for CA		32
	disassembly pos. 30 (2x),31,27,28,34,35 (2x),26,A72	13	
	check pos. A72 , sealing and pressing-on		A72
	check the wear and "cleanness" pos. 26		26

D6	disassembly pos. 1,9,3,2,8	9,10,11	
	check functional surfaces pos. 2,3,8 (804)		2,3,8 (804)
D7	proceed with the steps D8, D9, D10, D11 in this order		
D8	disassembly pos. 74	16	
	check the wear of pos. 74 and the surface between pos. A46 and A70	17	74
	disassembly pos. A46, 73	17	
	check the quality of external surface pos. 73 and sealings pos. A46		73,A46
D9	everething as in D8		
D10	CA leaks in pos. 67 Yes: disassembly pos. 67	21	67
	NO		
	disassembly pos. 65+80,A74,79,49 (2x),54,66,68,69,A75+67	2,3,5,6,21	A75,54,68,69
	NO		
	disassembly pos. A39,A40,A41,46	7	
	check sealings pos. A39,A40,A41		
	check surface pos. 46 and seading pos. A41		A39,A40,A41,46
	NO		
	disassembly pos. 59, A73	4,8,(20)	A73(41)
D11	disassembly pos. 65+80,A74	2,3	
	check inner surface pos. 65		65,80
	check sealings pos. A74	19	A74(63,64)
	disassembly pos. 79,49,54,66,68,69,A75+67	6	66
	check external surface pos. 66	5,6	
	check pos. 68	6	68
	NO		
	disassembly pos. A39,A40,A41,46	7	
	check sealings pos. A40		A40
	check surface pos. 46 and seating pos. A40		A40,46
D12	disassembly pos. 32	1	
	disassembly pos. 30 (2x),31,27,28,34,35 (2x),26,A72	13	
	check tightening pos. 25	14	
	disassembly pos. 25,24	14	25,24
	NO		
	disassembly all		A70
D13	check the lenght of BR and thickness of the join materials		
	NO		
	disassembly pos. 32	1	
	disassembly pos. 65+80,A74,61,60	2,3,4	
	fill in oil	4	
	if necessary disassembly all		
	check functional surfaces and sealings pos. A70,A71,A73,59		A70,A71,A73,59
D14	disassembly all		
	check functional surfaces and sealings pos. A70,A71,A73,59		A70,A71,A73,59

10. Service set:

Order Nr. of service set is S-1002002.

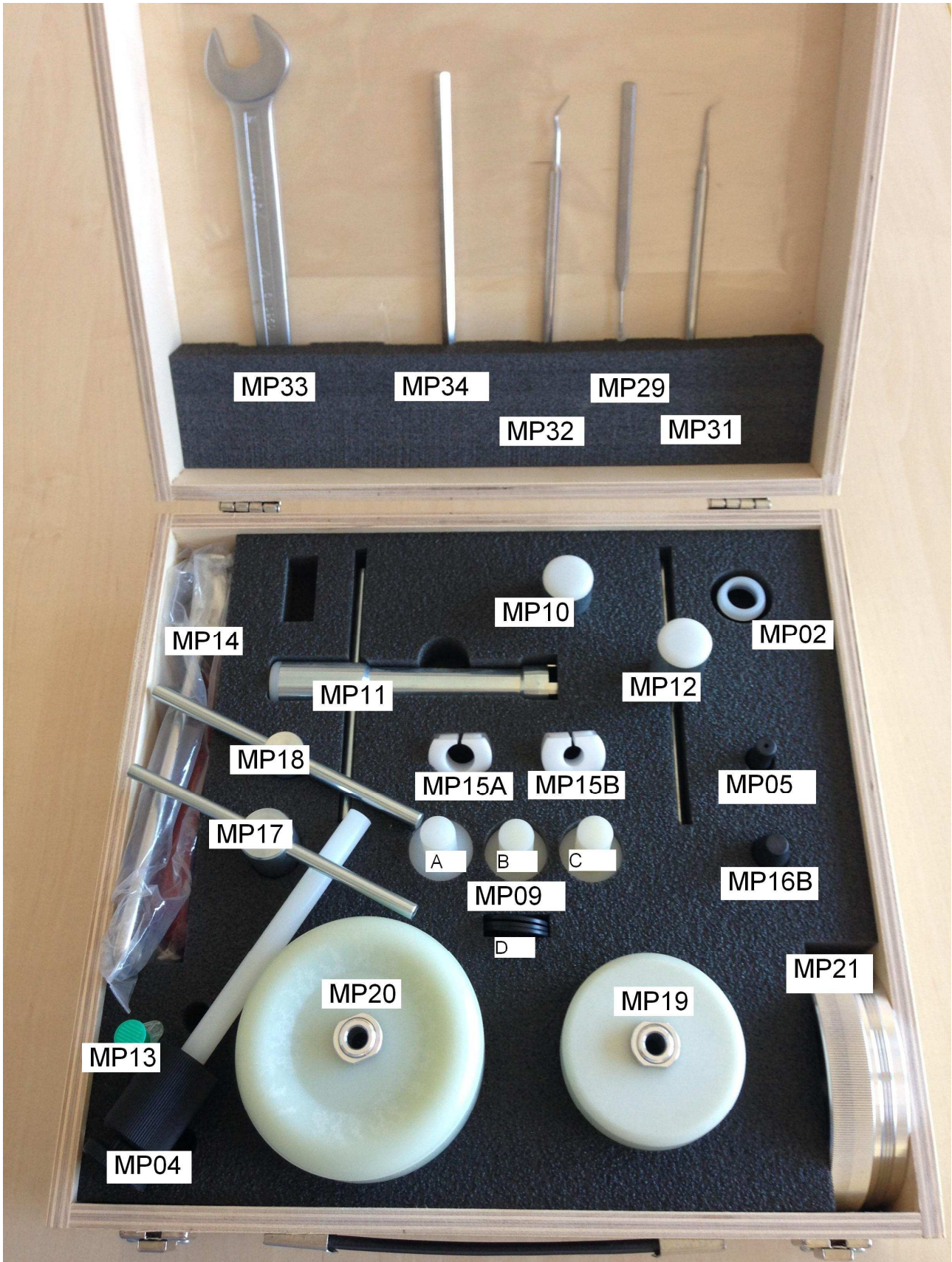

Service stand for assembling and disassembling of riveting tool is not piece of service set.
Order Nr. of service stand is S-1005000.



11. List of special tools in the service set:

<i>S-1002002 Service set for AP tool (version 2016)</i>				
<i>Marked</i>	<i>Article Nr.</i>	<i>Pcs/set</i>	<i>Name of special tool</i>	<i>Specified for riveting tool</i>
MP02	S-1002020	1	Threader MP02	SERIE 1, SERIE 2, SERIE 3
MP04	D-1003040	1	Adjustable stop MP04ABC	SERIE 1, SERIE 2, SERIE 3
MP05	D-1002050	1	Threader MP05	SERIE 1, SERIE 2, SERIE 4
MP09A	D-1003090	1	Stop MP09A	SERIE 1, SERIE 2, SERIE 3, SERIE 4
MP09B	D-1003091	1	Stop MP09B	SERIE 1, SERIE 2, SERIE 3, SERIE 4
MP09C	D-1003092	1	Stop MP09C	SERIE 1, SERIE 2, SERIE 3, SERIE 4
MP09D	D-1003095	3	Stop washer MP09D	SERIE 1, SERIE 2, SERIE 3, SERIE 4
MP10	S-1002100	1	Wrench MP10	SERIE 1, SERIE 2, SERIE 3, SERIE 4
MP11	S-1002110	1	Wrench MP11	SERIE 1, SERIE 2, SERIE 3, SERIE 4
MP12	S-1002120	1	Wrench MP12	SERIE 1, SERIE 2, SERIE 3
MP13	S-1002130	1	Oil filling tool MP13	SERIE 1, SERIE 2, SERIE 3, SERIE 4
MP14	N-5200900002140	1	Belt wrench 23/600	SERIE 1, SERIE 2, SERIE 3, SERIE 4
MP15A	D-1002150	1	Sleeve MP15A	SERIE 1, SERIE 2, SERIE 3
MP15B	D-1002151	1	Sleeve MP15B	SERIE 4
MP16B	D-1002161	1	Threader MP16B	SERIE 1, SERIE 2, SERIE 3
MP17	S-1002170	1	Wrench MP17	SERIE 4
MP18	S-1002180	1	Wrench MP18	SERIE 4
MP19	S-1002190	1	Oil filling tool MP19	SERIE 1, SERIE 4
MP20	S-1003200	1	Oil filling tool MP20	SERIE 2, SERIE 3
MP21	D-1003205	1	Oil filling reduction MP21	SERIE 3
MP29	N-5200900002330	1	Dissecting needle	SERIE 1, SERIE 2, SERIE 3, SERIE 4
MP31	N-5200900002310	1	Twin ball- burnisher	SERIE 1, SERIE 2, SERIE 3, SERIE 4
MP32	N-5200900002320	1	Twin float	SERIE 1, SERIE 2, SERIE 3, SERIE 4
MP33	N-4900000000002	1	Nut wrench 19 spec.	SERIE 1, SERIE 2, SERIE 3, SERIE 4
MP34	N-4100000000007	1	Imbus key 7 ISO 2936	SERIE 3

