

ULTIMO/ ALTO STAINLESS STEEL SINK INSTALLATION



Plumbing connections must be installed to the requirements of AS/NZS 3500 by a qualified plumber. Modifying the product is not recommended and will not be covered under warranty.



BEFORE INSTALLATION:

Inspect thoroughly to ensure the product has not been damaged and is correct.

Installation is acceptance of goods. By installing the sink, the owner accepts that the product is free of blemishes or imperfections, including scratches, damages and discolouration.

NO CLAIMS FOR DAMAGES OR INCORRECT PRODUCTS WILL BE RECOGNISED AFTER INSTALLATION.

If wall mounted tapware is to be used, consideration should be made for the length of outlet and positioning of the sink on benchtop. If tapware is to be bench mounted, allow suitable top width for fitting tapware.

Templates are supplied only as a guide. Refer to the physical sink for accurate measurements of the countertop cut-out hole. For under mount installation, please refer to the sink directly.

INSTALLERS TO COMPLETE

Date Installed:	
Installer's Name:	
License #:	
Business Name:	
Phone #:	
Product Installed:	
Signature:	

* Please leave document to home occupier for future reference.

INCLUDED IN THE BOX:

Sink, cut-out template, basket waste and fixing clips.

TOP/INSET MOUNT INSTALLATION

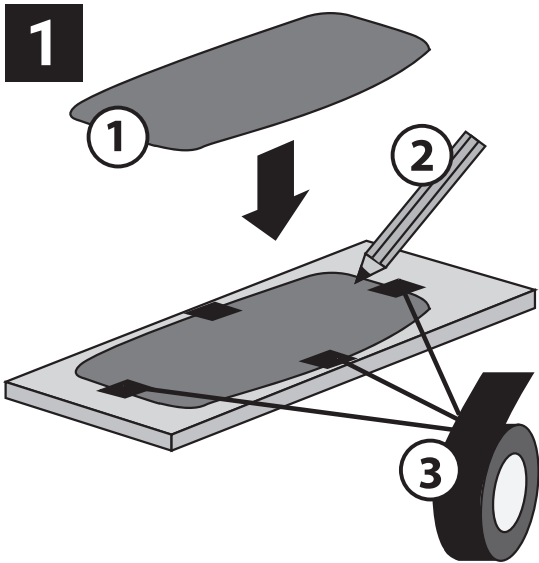

① Use inset mount template provided (check the template against the sink to be installed) then trace and cut out the benchtop.

② Position the inset template on the countertop surface and trace the cut line with a pencil. Make sure that the sink is perfectly centered and the outline is parallel to the counter.

③ Place masking tape along the centre of the cut line to avoid chipping or scratching caused by the cutting tool.

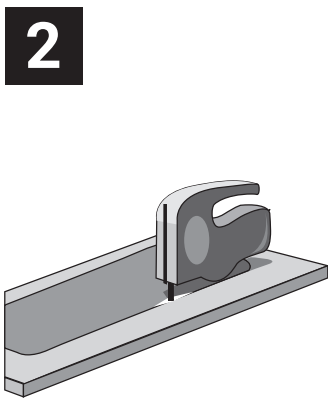

Use a proper device when cutting on the countertop. Cut according to marked cut-line.

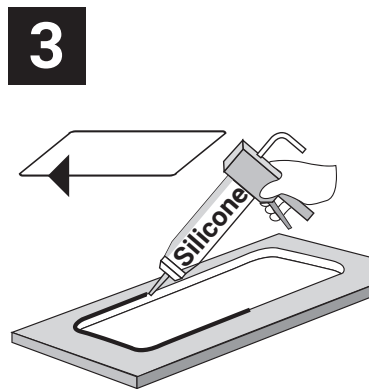

Apply a bead of silicone adhesive to the bottom of the sink rim and lower the sink into the cut-out hole.

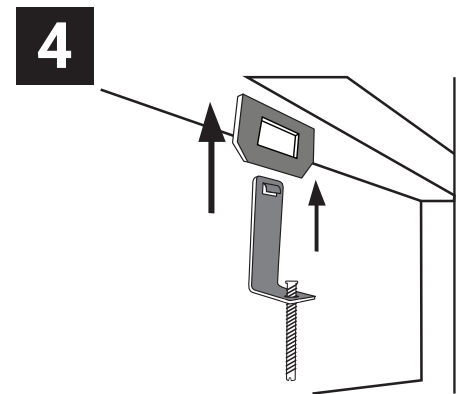

Attach mounting clips to the prongs protruding from the underside of the sink rim. Make sure the hooked side of the mounting clip is facing away from the sink.

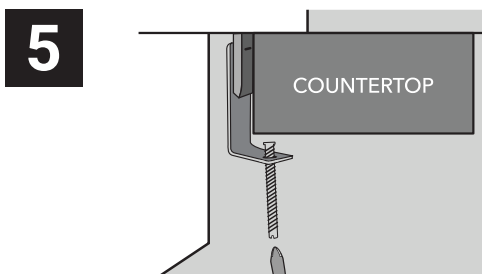

Position the bottom of the mounting clip so that it is gripping the countertop. Use a screwdriver to tighten the screws until the mounting clip is snug against the countertop.

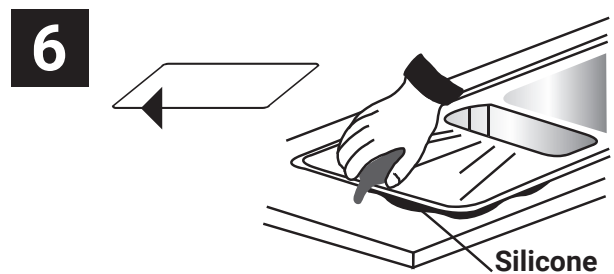

Apply weight to the top surface evenly to aid the drying of the applied silicone ensuring sink rim is evenly spaced around the cut-out. Wipe off any excess silicone.

7 Plumb up tapware and waste fittings.

***Note: Cover sink after installation to protect surface for the end user.**

UNDERMOUNT INSTALLATION

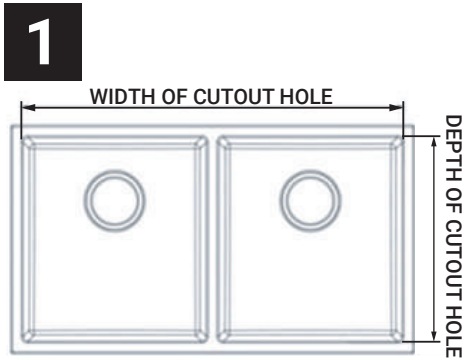

1 Measure the internal width and depth of the sink, cut out the bench top at desired location.

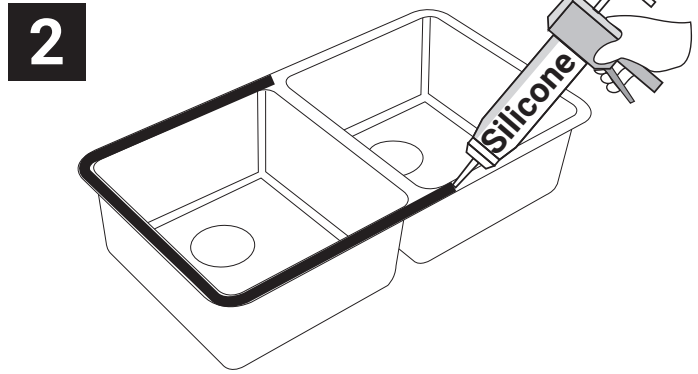

2 Apply silicone to the top of the sink rim. Do not let the silicone dry before the sink is fitted to the benchtop. Place sink into position.

3a

OR

3b

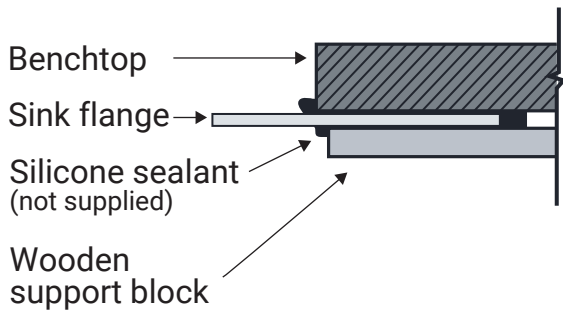

Sandwich Technique - Fix support board and ensure sink flange sits firmly and flat against the top benchtop surface.

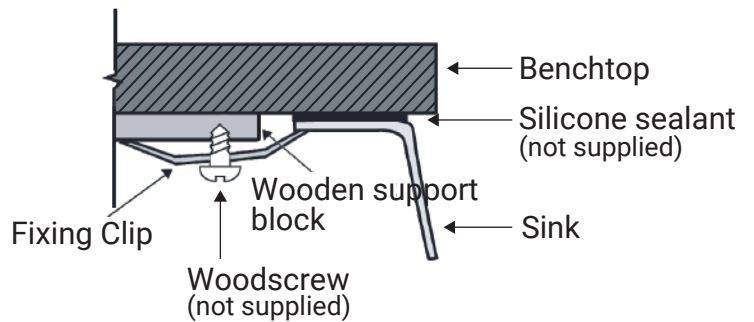

Fixing Clips - For solid benchtops, ensure to fix wooden blocks to the underside of the bench. One fixing clip end should rest on the wooden block and opposite end is to rest under the sink rim.

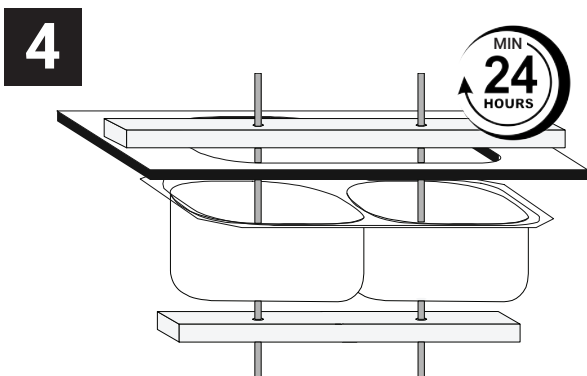

4 Lay a timber piece across the bench top and under the sink. Place a clamp through to hold the sink in place. Leave this for **a minimum of 24 hours** for the silicone sealant to cure.

CLEAN & CARE:

Arova Ultimo/Alto sinks are resistant and durable. This means looking after them is really simple.

Everyday Clean: Apply dishwashing liquid to a soft bristle brush and brush in circular motions. Rinse thoroughly with clean tap water.

Stubborn Stains: Use Bar Keepers Friend or white vinegar to clean limescale or other stains. Rinse thoroughly clean tap water.

Grey Marks: Apply some cooking oil to the area and rub with a soft cloth in circular motions to release the metal abrasion marks.

Things to Avoid

- Metallic scourer or steel wools
- Bleaches or cleaners containing chlorine
- Silver dip cleaners
- Strong alkaline agents or other solvent
- Drain unblocking chemicals
- Strong acids like denture cleaner
- Abrasive cleaners
- Hot pans or pots
- Prolonged contact with foods like salt, vinegar, fruit juice, reduce and etc.
- Ziptap boiling water drips to particular spot

AROVA OFFERS LIFETIME WARRANTY ON ULTIMO SINK RANGES AND 25 YEARS WARRANTY ON ALTO SINK RANGES

Warranty Conditions

- This warranty is not transferable, and limited to the original purchaser of the product, installed in accordance with the installation instructions and used in a domestic/residential setting.
- Lifetime warranty / 25 years warranty is for sink only. Waste fittings and other accessories are covered for (12) months.
- The sink must be installed by a qualified installer in accordance with the instructions and connected by a licensed plumber.
- Warranty starts from date of purchase and only applies when the proof of purchase is produced.
- Faults are caused by defective production.
- For approve warranty claims, Arova has the sole discretion to either repair faulty components or replace the whole product with the same or an equivalent model where the balance of the warranty period from the original date of purchase will take effect.

Not Covered By This Warranty

- Normal wear and tear including scratches, chips, stains or discolouration
- Unsuitable or improper use
- Inadequate or complete lack of maintenance
- Failure was caused by incorrect installation
- Outdoor use other than when placed in a fully covered Alfresco area with 2 walls
- Incidental costs, such as product removal or re-installation, visits and calls of tradesperson or specialised technicians, costs borne by the customer due to the unavailability and/or nonuse of the product.
- Any imperfections in the finishes materials used should not be considered as faults but a typical characteristic of these products crafted from natural materials.

For up to date warranty information please go to:
<https://www.arova.com.au/pages/warranty>

For any other further information please contact your nearest Arova showroom.