

COMO Compact Rain Shower - CS108

Please check over carefully the surface and accessories to avoid any damage and missing.

No.	Description	Qty.
1	Inlet Adaptor	x 1
2	Top Rail	x 1
3	Inlet Body	x 1
4	Hand Shower Holder	x 1
5	Hand Shower	x 1
6	Shower Head	x 1
7	Shower Hose	x 1
8	Allen Keys	x 2
9	Grub Screws	x 4

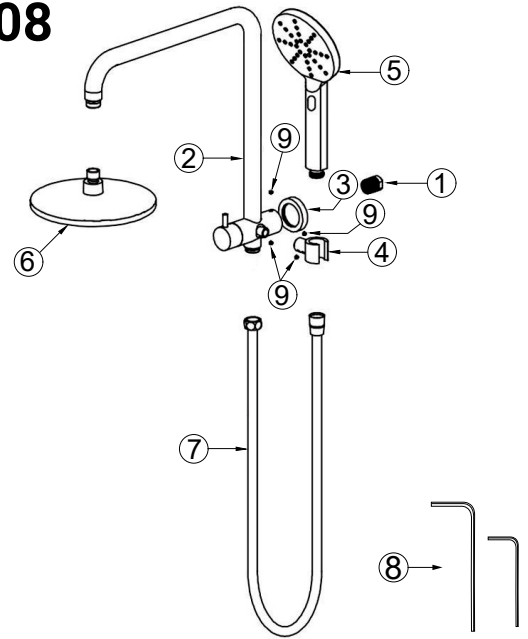

Instructions:



Working pressure: 0.05-1 Mpa.

Products are manufactured as per standard AS/NZS 3662:2005.as per Australian standard, and with WaterMark & WELS certificate as shown in the packing.



Working Temperature: 0-55 °C .



All surfaces should be cleaned with water or mild liquid detergent.

Do not use cream cleaner or citrus based or chemical cleaning products.

Installation:

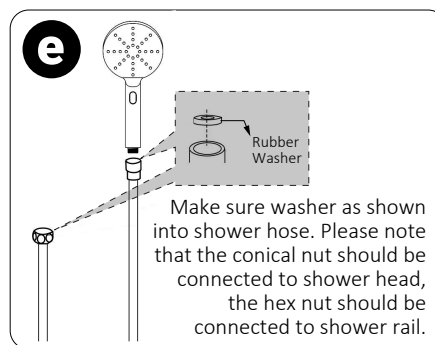
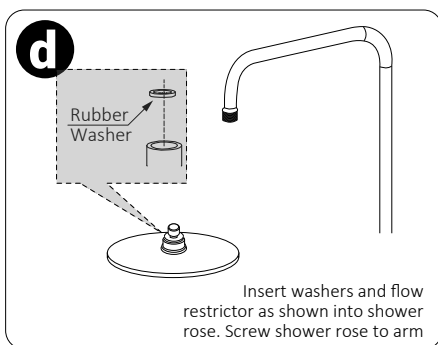
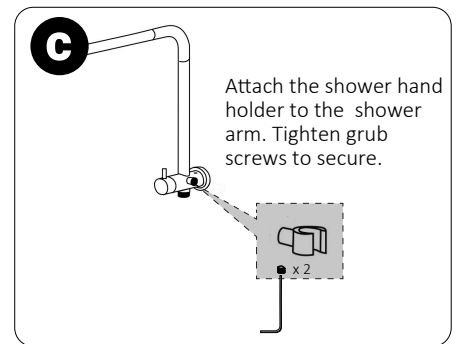
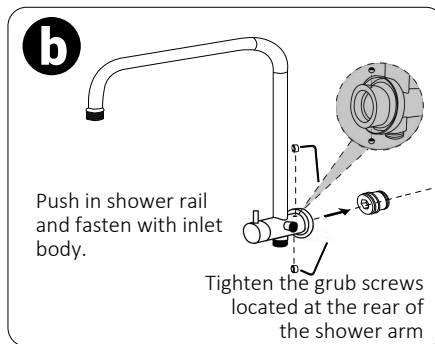
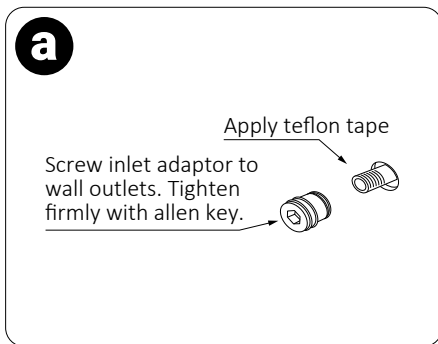

Warranty:

All products are guaranteed as below:

- 10 years - brass body, shower head, wall elbow, shower arm, shower rail
- 5 years – hose, hand piece, slide bracket, diverter and finish