

## Installation Instructions For The Lingenfelter High Flow LS9 Supercharger Front Cover (6.2L LS9 V8 engine)



PN: L250110309

# Parts List

## LPE LS9 SC cover, PN L250110309

#	Part number	Description
1	XX03529-0006	LPE LS9 SC front cover assembly
10	47503	Stainless socket head cap screw, M4x0.7x12
1	L960130709	Solid SC isolator coupling
2	SPIR-69427	Supercharger cover alignment dowel pin
1	ETN307901	LS9 pulley cap
1	82180	Permatex Ultra Black Gasket Maker, 3.35 oz.
1	ETN86063	Vacuum bypass positioning tool
1	L920030000	LPE premium fuel decal, 93 octane
1	L450110095	LPE diagnostic port cover kit
1	L920010000	LPE decal
1		Instructions

### Tools & Materials Required

- Fuel line disconnect tool
- Fork type pry tool
- Ratchet
- Torque wrench
- 6 mm socket
- 7 mm socket
- 10 mm socket
- 13 mm socket
- 19 mm socket (for wheel lug nuts)
- 21 mm socket
- 3 mm hex bit Allen socket
- 8 mm hex bit Allen socket
- 6" socket extension
- 1/2" breaker bar
- 5/16" nut driver or socket
- T-15 Torx head driver or socket
- 5 mm Allen wrench or socket
- Hose clamp pliers or standard pliers
- Loctite Blue, GM PN 12345382 or equivalent
- Loctite 567 thread sealant or equivalent
- Jack
- Jack stands (2x)
- Wheel ramps
- Vehicle hoist (optional)
- Mallet
- Razor blade or gasket scraper
- Drill (optional - only need if changing intake gaskets)
- 1/8" drill bit (optional - only need if changing intake gaskets)

### Additional Required Components

- 2.38" or 2.65" 11 rib 10 bolt supercharger pulley
- LPE ZR1 air intake kit PN L650150309
- 76 mm, 90 or 100 idler kit (size depends on pulley combination being used - see Table 1 on page 38)
- 11 rib belt (length depends on pulley combination being used - see Table 1 on page 38)

### Optional Items

- Fuel line disconnect tool MAG69-12-57-001
- EFILive programming and scan tool EFIFS2-T
- 160 degree thermostat L310065307
- High capacity intercooler radiator kit KAT-6044
- OD LS9 balancer kit 14% OD L220100309
- LPE GT9 LS9 camshaft L210150309 (valve springs required for GT9 camshaft)
- Comp cams 918 valve springs 26918-16
- Throttle body gasket 12576549
- Supercharger manifold gasket kit 19180613
- Supercharger manifold gasket rivets 12558759 (also part of manifold gasket kit)
- Supercharger cover seal 12613457
- Supercharger insulator seals (pair required) 12609472
- Supercharger actuator kit 19180860
- LPE air filter service kit SB-88-0005
- Replacement air filter L660070105
- 102 mm throttle body SD102MME (requires porting of front cover and adapter harness)
- 105 mm throttle body SD105MME (requires porting of front cover and adapter harness)
- LS2 TO LS1 adapter harness CE-108115

Lingenfelter High Flow LS9 Supercharger Front Cover, aka “snout”, specifications:

- The Lingenfelter front supercharger cover casting was designed to provide a more direct path for the airflow from the throttle body to the supercharger. This provides reduced inlet restriction (reduced pressure drop) resulting in increased boost and reduced supercharger work. This results in reduced supercharger parasitic losses, reduced supercharger outlet temperatures and increased horsepower - especially at higher supercharger speeds.
- The cover casting is based on the inlet design first used on the Lingenfelter modified 2009 ZR1 that has run 9.813 seconds at 145.74 mph in the quarter mile.
- Drag strip, chassis dynamometer and engine dynamometer proven design.
- The Lingenfelter cover is cast from 356T6 aluminum.
- The bearing support area is already machined to provide clearance for small diameter pulleys.
- All castings are 100% leak checked using an OEM decay type leak checking process
- Casting has also been designed with extra material in order to allow for the use of larger throttle bodies including 100 mm throttles. Inlet porting and/or machining are required for proper 100 mm throttle body fitment.
- Supercharger cover includes all new internal components – no core exchange required.
- For increased durability and reliability, especially under higher shaft speeds and increased supercharger loads, a stainless steel 10 bolt hub is pressed and then pinned onto the supercharger cover drive shaft.
- Pulleys are available from Lingenfelter Performance Engineering in 2.67” (19% overdrive) and 2.38” (32% overdrive) diameter versions. These measurements are as measured with a 2.5 mm check ball. If measuring the pulley diameter directly with a caliper the diameters will be closer to 2.60” and 2.35”.

The LPE front cover kit is not supplied with a pulley so you must order a supercharger pulley to go with this cover. Different belt and idlers are also required depending on the pulley size and damper size you have selected. See the Table 1 on page 35 for information on the supercharger speeds for different pulley combinations and for information on the required idler kits and belts needed for different pulley combinations.

For an otherwise stock engine on premium pump fuel LPE recommends the use of the 2.67” pulley. Both pulley sizes require recalibration of the production ECM.

For 2009-2013 ZR1 Corvette applications the LPE LS9 supercharger cover requires the use of a new air intake system, LPE part number L650150309. This air intake system features revised duct work to connect to the new throttle body location along with a large surface area filter with a sealed filter shroud designed to keep unwanted hot engine compartment air out of the inlet.

**Read the entire instruction manual before beginning installation. Many of the stock parts will be used in reassembly. Some steps may require two (2) people.**

**When referencing the side of the vehicle, the driver side of the vehicle is considered the left side and the passenger side of the vehicle is considered the right side of the vehicle.**

**Torque value warning - the torque values for the fasteners are provided in metric (Nm) and then imperial units. For the imperial units some are referenced in lb-ft and others in lb-in. Make sure you notice the difference and set your torque wrench correctly.**



1. Open the hood of the vehicle. If you have been driving the vehicle, allow the vehicle to cool down for a few hours before beginning this work.

Some of the pictures in these instructions show the hood removed. This was done to make it easier to take the pictures. Although you can remove the hood in order to provide easier access, it is not required that you do so.



2. Open the rear hatch and open the battery compartment cover. Using a 10 mm socket wrench, disconnect the negative (-) battery cable from the terminal on the battery. Cover the cable end with electrical tape so accidental connection to the battery does not occur.



3. Remove the engine sight shield (engine cover) by pulling up on the cover to remove it from the three (3) mounting posts.



4. Disconnect the mass air flow (MAF) sensor electrical connector located at the air inlet duct.



5. Remove the plastic loom holder from the factory intake duct but leave the MAF sensor harness loom in the holder. Be careful not to damage the factory plastic fastener.



6. Disconnect the throttle actuator electrical connector from the throttle body.



7. Disconnect the positive crankcase ventilation (PCV) fresh air tube from the passenger side of the air inlet duct. Remove the PCV inlet tube from the air filter bellows by pushing up on the release lever. Next pull the tube free from the air duct barb. This same removal method will be used with the other similar PCV connections.



8. Disconnect the PCV lines from the dry sump oil tank.



9. Remove the rear hood seal from the cowl.



10. Using a 5/16" nut driver or socket, loosen the clamp on the throttle body



11. Remove the air inlet duct and air filter housing by pulling straight up on the air inlet duct assembly to detach the rubber grommets from the mounting pegs.



12. Remove the supercharger drive belt by using a 1/2" breaker bar to rotate the supercharger belt tensioner and then remove the supercharger belt from the pulleys and tensioner.

Depending on your pulley combination, you may or may not be using this belt over again. (See Table 1 on page 35)



13. Disconnect the electrical connector from the supercharger actuator solenoid at the left front of the supercharger.



14. Disconnect the active exhaust vacuum hose that routes from the left side of the engine compartment to the front of the supercharger.



15. Disconnect the brake boost vacuum hose that routes from the left side of the engine compartment to the front of the supercharger.



16. Disconnect the fuel injector and ignition coil harness connector from the driver side of the engine.



17. Disconnect the air outlet pressure sensor (boost pressure) harness connector from the sensor on the driver side of the vehicle.



18. Disconnect the PCV fresh air hose line from the left side valve cover (at the rear of the engine).



19. Disconnect the fuel injector and ignition coil harness connector from the passenger side of the engine.



20. Disconnect the supercharger outlet air temperature sensor (IAT2) electrical connector from the sensor on the right side of the intercooler.





21. Disconnect the barometric pressure sensor electrical connector on the right side (passenger side) of the intercooler.



22. Disconnect the PCV fresh air hose line from the right valve cover (at the front of the engine).



23. Move the PCV air house assembly out of the way by rotating it up and over.



24. Using a fork type pry tool, carefully pry the wiring harness fastener clip below supercharger boost control solenoid.



25. Using a fork type pry tool, carefully pry the wiring harness fastener clip on the front of the driver's side fuel rail.



26. Using a fork type pry tool, carefully pry the wiring harness fastener clip located on the rear of the driver's side fuel rail.



27. Using a fork type pry tool, carefully pry the wiring harness fastener clip located on the front of the passenger side fuel rail.



28. Using a fork type pry tool, carefully pry the wiring harness fastener clip located on the rear of the passenger side fuel rail.



29. Disconnect the ignition coil electrical connectors from the ignition coils on the right side of the engine.



30. Disconnect the ignition coil electrical connectors from the ignition coils on the left side of the engine.



31. Disconnect the purge line from the purge solenoid on the left side of the supercharger front cover.

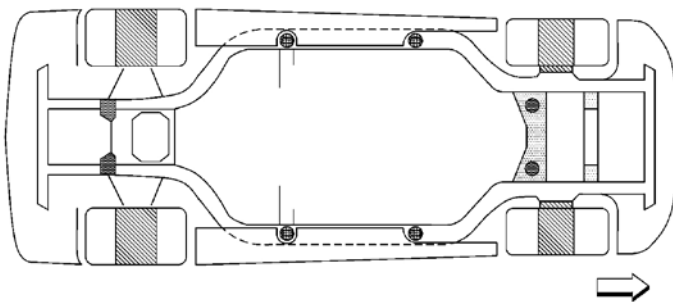

32. Raise the vehicle with a vehicle hoist or a jack and jackstands. Be careful to follow the GM lifting procedures on the ZR1 Corvette due to the carbon fiber aerodynamic components being easily damaged and the low ride height of the vehicle.

Do not place the jackstands under the suspension or the engine cradle since you will need to be able to lower the engine in relation to the body of the vehicle.



33. Using a 13 mm socket and the 6" extension, remove the sway-bar bushing to cradle bracket bolts (2 per side) and then remove the brackets from both sides. Allow the sway bar to swivel down but do not remove the sway-bar.



34. Using a 21 mm socket, loosen the four engine cradle retaining nuts on both sides.



35. Loosen the engine cradle nuts such that you have roughly a 1 inch (25 mm) gap between the nut and the subframe. You should still have several turns of engagement on the threads on each nut. Do not remove the nuts from the studs.

**NOTE:** If you are using a vehicle hoist, lower the vehicle back down so you can now work in the engine compartment area.



36. Starting with the back 6 bolts, remove the 10 mm bolts on the supercharger cover with a socket and extension.

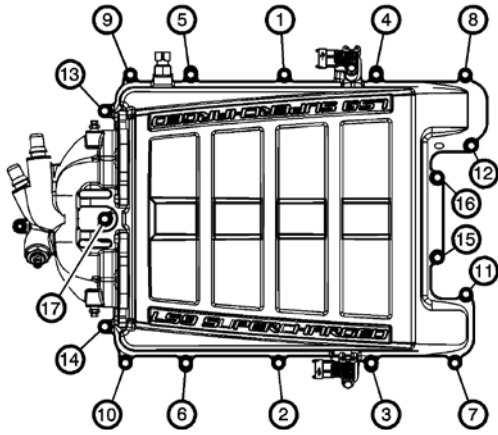

37. Seventeen (17) 10 mm head bolts secure the supercharger cover to the supercharger assembly.



38. Remove the supercharger cover from the engine.



39. With the intercooler fluid lines still connected to the cover, put the cover off to one side of the engine compartment and cover with a plastic bag or rags to prevent dust and debris from getting into the cover.



40. Inspect the supercharger cover seal. Replace if damaged. [GM PART #12613457].



41. Inspect the supercharger insulator seals. Replace if damaged [GM part # 12609472].



42. Remove the PCV dirty air hose line from the passenger side of the supercharger.



43. Remove gas cap from gas tank.



44. Bleed the fuel system pressure to 0 psi at the service test port on the driver side fuel rail.



45. On the driver side of the engine, remove the lock and disconnect the fuel feed-to-rail hose from the fuel rail using the J-37088-A fuel line disconnect tool or similar tool (available from LPE, part # MAG69-12-57-001). Use a rag to catch any excess fuel that may spill from the lines.



46. Using a 8 mm socket and extension, remove the supercharger bolts.

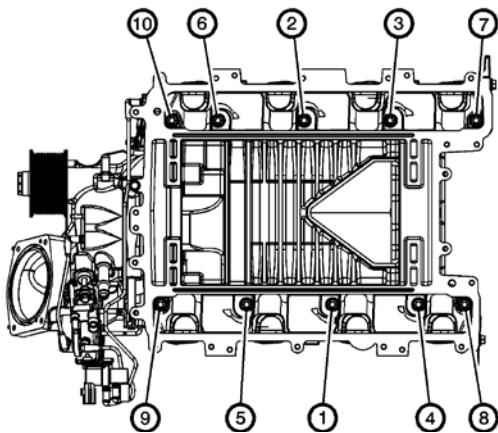

47. Ten (10) 8 mm socket head bolts retain the supercharger assembly.



48. With the help of an assistant, remove the supercharger assembly. The supercharger, throttle body, fuel injection rail and fuel injectors may be removed as an assembly. Use care not to reposition or bend the intercooler cover dowel pins. Do not lift the supercharger assembly from the black plastic vacuum actuator as you risk damaging the actuator.

NOTE - Do not allow dirt or debris to enter the passages of the supercharger or the engine.

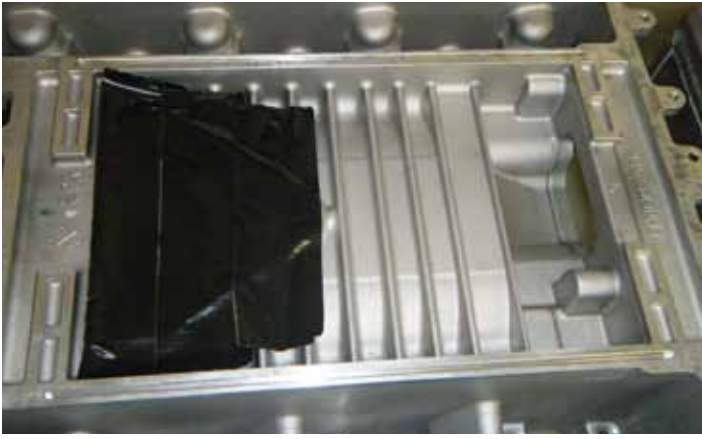

49. Cover the inlet area of the supercharger to prevent dirt or debris contamination onto the rotors.



50. Wipe the heads clean of oil using a solvent dampened rag and then vacuum the area of dust and debris. It is very important to maintain a clean work environment.



51. Cover the intake ports on the engine with tape or rags to make sure nothing enters the engine.



52. Inspect the intake manifold gaskets on the supercharger assembly. If they are damaged you will need to drill out the gasket rivets and install new gaskets and gasket rivets [GM PART # 19180613].





53. Using a 10 mm socket, remove the four (4) bolts that secure the throttle body to the supercharger assembly. Remove the throttle body.



54. Disconnect the engine inlet air pressure sensor electrical harness.



55. Using a 10 mm socket, remove the bolt to the inlet air pressure sensor from the supercharger front cover.



56. Using a 10 mm socket, remove the bolt to the purge solenoid from the supercharger front cover.



57. Remove all vacuum hoses from the bypass valve actuator and boost control solenoid. Using a 10 mm wrench, remove the two (2) bolts securing the bracket as shown.



58. Carefully remove the throttle body gasket from the front cover assembly. Inspect the gasket. If it is in good condition it will be re-used later on. If it is damaged you will need to obtain a replacement gasket [GM PART #12576549].



59. Using a 10 mm socket and extension, remove the six (6) bolts that secure the front cover to the supercharger assembly.



60. Using a mallet (or prybar) gently knock the front cover loose from the supercharger assembly. It is located in place by two dowels and the pins in the supercharger shaft coupler so you are just using the mallet to loosen the adhesive between the cover flange and the supercharger housing.



61. Remove the front cover from the supercharger assembly.



62. Remove the spring loaded isolator coupling from the supercharger assembly (or it may be on the front cover assembly).



63. Inspect the cover mounting surface on the supercharger assembly. Clean off any remaining adhesive with a razor blade.

If you have powdered rust in the supercharger shaft housing bore, this is from the spring on the isolator contacting the shaft on the front housing and is fairly common. Wipe off the dust.



64. Install the supplied plastic isolator coupling on the pins on the shaft in the supercharger assembly. The holes are evenly spaced so it doesn't matter what set of holes you use. The new isolator coupling will be a tight fit on the pins.

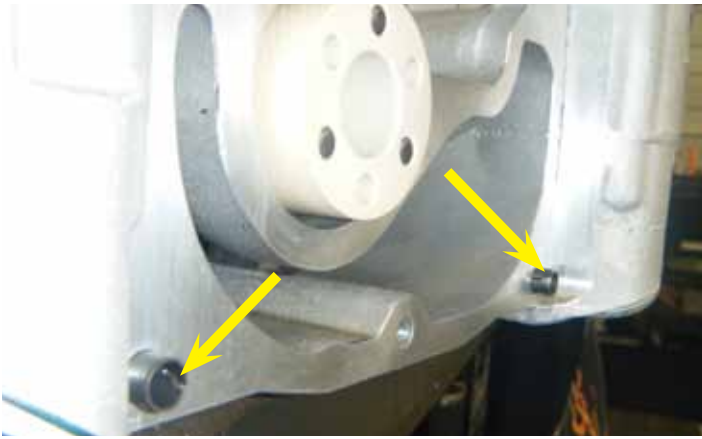

65. Remove the old dowel sleeves from the front cover/housing. Install the supplied dowel sleeves into the LS9 supercharger housing. Install the sleeves in the bottom left and bottom right hand corner of the supercharger housing. DO NOT install sleeves on the front cover.

**NOTE:** Some early engines may not have dowel sleeves in the cover. Dowel sleeves should be used on these early engines as well. See example image for correct location.



66. Apply a thin film of the supplied Permatex Ultra Black Gasket Maker to the Lingenfelter LS9 cover flange surface.



67. Install the new cover onto the supercharger assembly. The three pins sticking out of the supercharger drive shaft in the front cover go into the three holes in the plastic coupler that are not occupied by the pins from the supercharger assembly.



68. Install the six (6) cover bolts with a 10 mm socket and extension. Torque to 27 Nm (20 lb ft). The torque sequence is not critical on this component. With the plastic cover removed from the end of the shaft, tap the end of the shaft with a rubber mallet to seat the plastic shaft coupler. Check to make sure the supercharger assembly turns smoothly. If it doesn't turn freely, tap the end of the shaft again to fully seat the plastic coupler.



69. Install the throttle body gasket that you removed from the stock front cover onto the new supercharger front cover.

If you are using a throttle body larger than 90 mm (stock is 87 mm) and have modified the front cover for the larger throttle body you will not be able to use the factory rubber gasket and you will have to use a paper gasket or liquid gasket material.



70. Install the supercharger pulley onto the hub on the supercharger shaft.

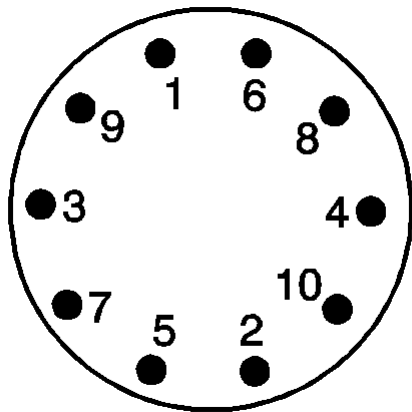

71. Apply a small amount of Loctite Blue to the supplied M4x0.7x12 socket head cap screws and, using a 3 mm Allen wrench or socket, secure the pulley to the hub with these screws. Use the pattern to the left to tighten the screws. Torque to 2.3 Nm (20.7 lb-in). For instructions on supercharger pulley removal, refer to page 34.



72. Using a 10 mm socket, torque the two (2) bypass actuator bolts to 18 lb-ft (25 Nm). In the new casting the bottom bolt hole is machined all the way through to the inside of the front cover so the bolt going into this hole needs thread sealant applied to the threads [Loctite 567 thread sealant or equivalent].



73. Use the set tool to set the actuator position [tool part # ETN86063]. Place the actuator set tool so that the actuator arm teeth are located in the position shown. Note the bypass set screw position.

NOTE: The front cover and bypass actuator are shown off of the vehicle for illustrative purposes only.

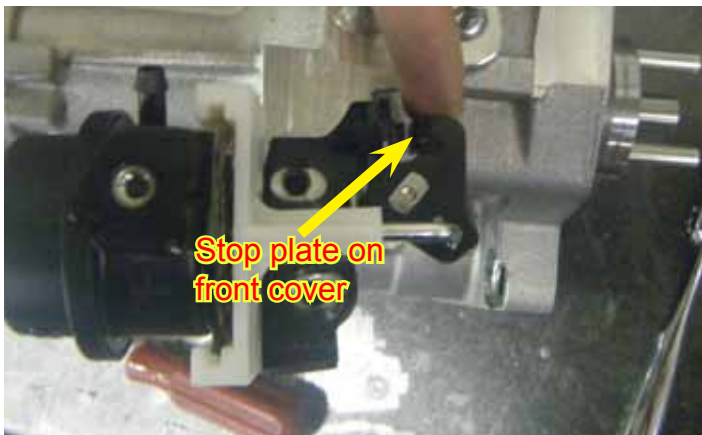

74. Hold the bypass stop plate back so that the bypass valve blade is in the closed position. The stop plate should not be touching the set screw on the bypass actuator. The set screw can be adjusted using a 3/32" Allen wrench.



75. Install the two (2) 10 mm bolts and torque them to 21 lb-ft (28.5 Nm).



76. Tighten the set screw so that it barely touches the stop plate on the front cover. After the initial contact, tighten the set screw 1/8 to 1/4 turn **more** to set the bypass valve blade into position. The set screw should now be touching the stop plate on the front cover. This will prevent the bypass valve blade from getting stuck on the front cover casting. Remove the bypass actuator set tool.



77. Install the boost control solenoid bracket assembly onto the front cover. Using a 10 mm socket, torque the fastener to 10 Nm (89 lb-in). Replace all vacuum hoses.

**NOTE:** Refer to the diagram on page 35 for the vacuum routing diagram.



78. Install the purge solenoid onto the front cover. Using a 10 mm socket, torque the fastener to 10 Nm (89 lb-in).



79. Install the inlet air pressure sensor onto the front cover. Using a 10 mm socket, torque the fastener to 10 Nm (89 lb-in). Plug connector back into inlet air pressure sensor.



80. Install the throttle body on the supercharger front cover. Using a 10 mm socket, torque the four (4) bolts to 10 Nm (89 lb-in).

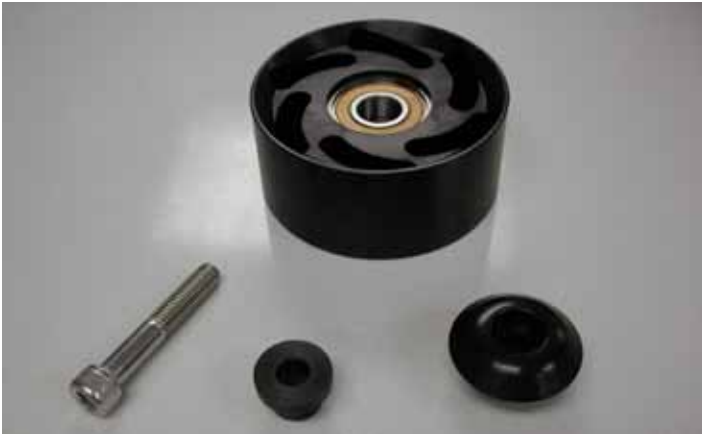

81. If you are using a pulley combination that requires a different idler, replace the factory idler at this time. Follow steps 79 to 81 for installing the new idler. See table 1 on page 37 for information on what size idler is needed for different pulley combinations.

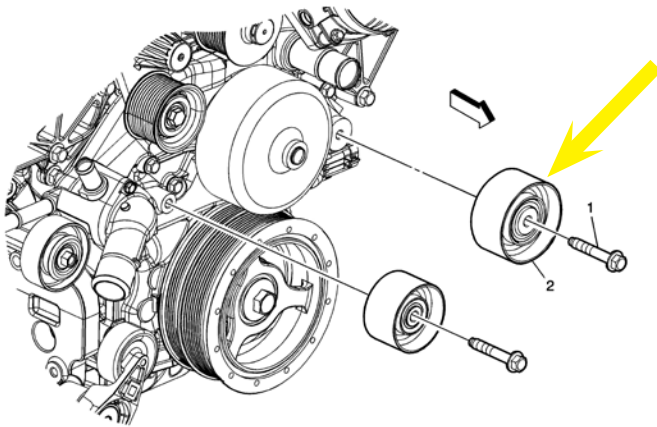

82. The idler to be replaced is the factory 90 mm idler found on the driver side of the vehicle (not the 76 mm idler found near the water pump and tensioner).

LPE also offers an aluminum double bearing 76 mm idler and the parts needed to replace the 76 mm idler found on the passenger side of the engine (LPE part # L250120309). Contact LPE or your LPE distributor for more information.



83. Using a 15 mm socket, remove the bolt that secures the factory 90 mm idler.



84. Place the supplied idler locating spacer on the back side of the idler. Place the supplied dust shield/cover on the front of the idler pulley. Put the supplied bolt through the idler and install the assembly on the engine.

Using an 8 mm hex bit Allen socket, torque the idler bolt to 50 Nm (37 lb-ft).



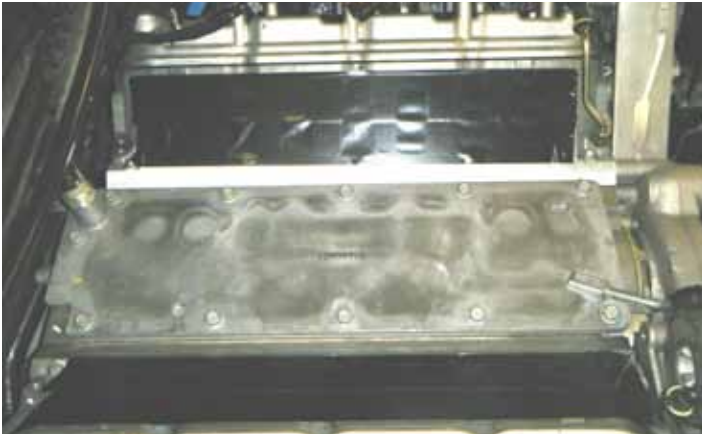

85. Make sure the cylinder head and engine area are free of loose debris. Remove the tape from the cylinder head intake ports.

**NOTE:** If you removed the fuel rail and injectors as part of this process, the fuel rail and injectors must be installed prior to the intercooler cover installation.



86. Apply a 5 mm (0.2 inch) band of threadlocker (Loctite Blue, GM PN 12345382 or equivalent) to the threads of the 10 supercharger bolts. Place the ten bolts into the supercharger.



87. With the help of an assistant, place the supercharger assembly back in place on the engine. Align the dowel pin at the right front of the supercharger to the cylinder head.

**WARNING:** Do not lift from by-pass actuator.



88. Torque down the ten (10) supercharger bolts, refer to the next step for the torque pattern and specifications.

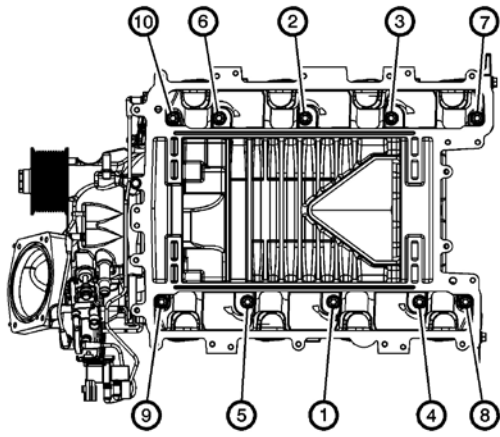

89. Tighten the bolts a first pass in sequence to 5 Nm (44 lb-in).

Tighten the bolts a final pass in sequence to 10 Nm (89 lb-in).

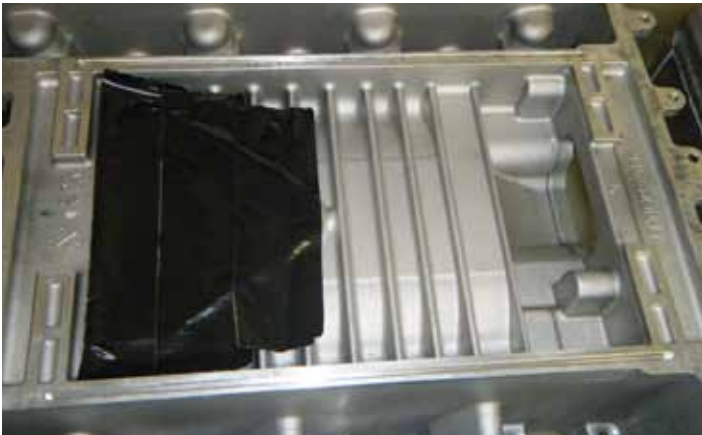

90. Remove the tape or other covering material from the supercharger housing.



91. Connect the PCV dirty air hose line to the passenger side of the supercharger front cover.



92. Connect the engine inlet air pressure sensor electrical harness.

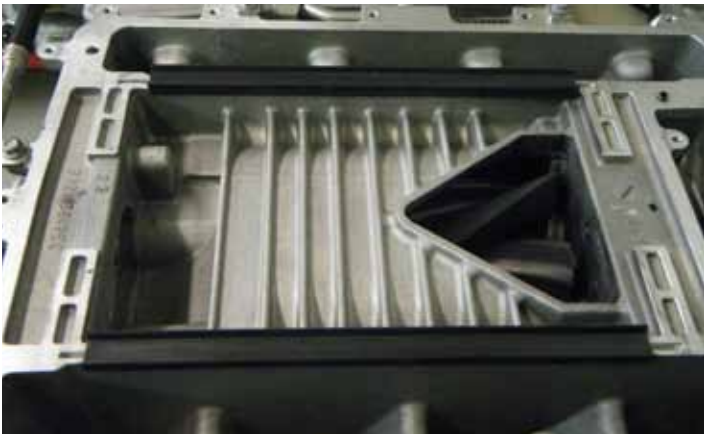

93. Install insulator seals on the supercharger assembly.



94. If you removed or are replacing the supercharger cover seal, install the supercharger cover seal.



95. Install the seventeen (17) supercharger cover bolts and the supercharger cover.

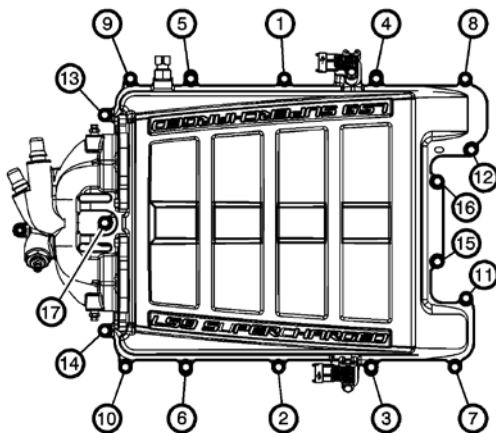

96. Tighten the bolts a first pass in sequence to 5 Nm (44 lb-in).

Tighten the bolts a final pass in sequence to 10 Nm (89 lb-in).



97. Reconnect the fuel line and safety clip on the passenger side of the vehicle.

98. Raise the vehicle back up in the air.



99. Using the jack raise the engine back up into position.



100. Using a 21 mm socket, tighten the four engine cradle stud nuts (two on each side) and torque to 110 Nm (81 lb-ft). You can now remove the jack from under the engine.



101. Using a 13 mm socket and the 6" extension, install the sway-bar bushing to cradle brackets and bolts on both the left and right side. Torque to 58 Nm (43 lb-ft).



102. Lower the vehicle back down on the ground and re-install gas cap



103. Connect the ignition coil electrical connectors to the ignition coils on both sides (8 coils).



104. Re-install the hood seal on the cowl.



105. Connect the PCV fresh air hose assembly to the left and right valve covers and the dry sump tank.

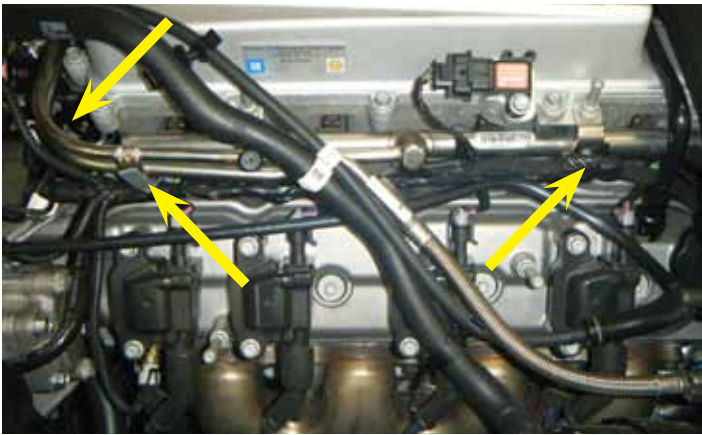

106. Re-attach the three (3) wiring harness fastener clips on the driver side of the vehicle.



107. Re-attach the two (2) wiring harness fastener clips on the passenger side of the vehicle.



108. Connect the IAT2 sensor electrical connector.



109. Connect the barometric pressure sensor electrical connector.



110. Connect the boost pressure sensor connector.



111. Connect the fuel injector and ignition coil harness connector on the driver side.



112. Connect the fuel injector and ignition coil harness connector on the passenger side.



113. Connect the brake boost vacuum line to the supercharger front cover.



114. Connect the active exhaust vacuum hose to the supercharger front cover.



115. Connect the electrical connector to the supercharger boost control solenoid and connect evap hose to solenoid.



116. Connect the electrical connector to the EVAP purge solenoid.





117. Connect the EVAP purge line to the purge solenoid.

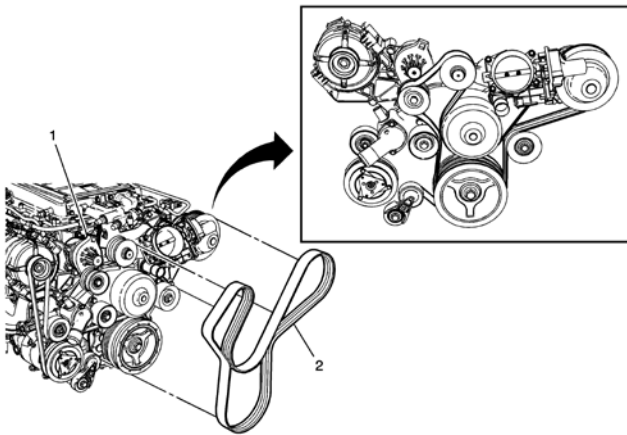

118. Install the supercharger drive belt. Depending on your pulley combination this may be the stock belt or a different length belt. See Table 1 on page 35 for recommended belt and idler sizes for the different supercharger pulley and damper diameter combinations.



119. Install the air intake system.

NOTE - the LPE LS9 front cover does not work with the stock ZR1 air intake. The LPE ZR1 air intake or a custom fabricated air intake must be used. Refer to the LPE ZR1 air intake instructions for installation method.



120. Connect the throttle actuator electrical connector.



121. Connect the mass air flow sensor connector.



122. Re-install the engine sight shield (engine cover) by pushing down on the cover to secure it to the mounting posts.



123. Program the vehicle's engine control module (ECM) as required for the combination of parts on your vehicle.

The different pulley ratio combinations will require different levels of calibration changes but all combinations require some level of calibration changes.



124. You can purchase vehicle programming hardware and software from LPE, you can send in your ECM for us to calibrate or you can have a local tuning shop calibration your vehicle.

**NOTE** - some pulley combinations require ignition timing changes in order to operate with pump gas. The increased boost levels risk damaging your engine if the correct calibration changes are not made.



125. DLC port cover kit installation.



126. Install the supplied diagnostic port (DLC port) cover onto the DLC port in the driver foot well. Secure the strap that retains the DLC cover to the vehicle.

This cover is meant to notify dealerships and other service facilities that this vehicle has custom programming installed for new supercharger pulley ratio and it should not be programmed with the stock GM calibration files when being serviced.



127. Start the engine and check for proper belt alignment and listen to make sure you do not have any vacuum leaks.



#### 128. LPE LS9 two piece pulley removal:

The Lingenfelter two-piece LS9 pulleys have twelve (12) holes on the face. Ten (10) of the holes are not threaded and these are used to secure the pulley to the hub. The two (2) holes are threaded to accept M4 x 0.7 fasteners. These two holes allow you to use two M4 x 0.7 screws to remove the pulley from the hub. To do so, remove the ten (10) M4x0.7x12 mm fasteners from the pulley and then thread two M4x0.7x14 or longer screws into the two additional holes. Tighten one screw and then the other to evenly work the pulley off of the hub.

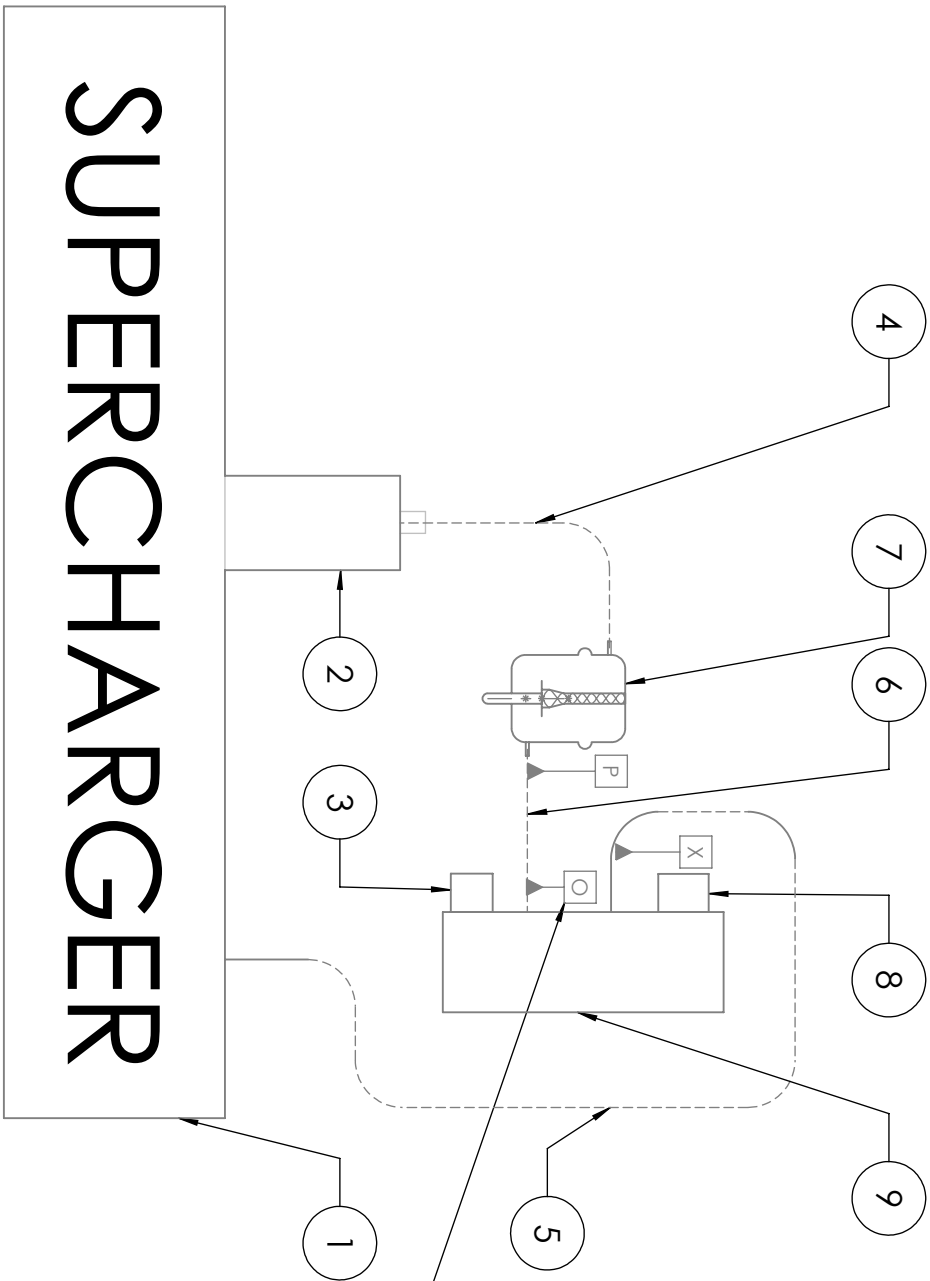

# SUPERCHARGER

<u>Part</u>	<u>Description</u>
1	Supercharger
2	Front cover
3	Electrical connector
4	Inlet vacuum signal
5	Boost vacuum source
6	Boost signal
7	By-pass valve actuator
8	Vent
9	Boost control solenoid

THE LABELED P, O AND X DATUMS ARE THE LABELS ON THE VACUUM LINES AND THEIR RESPECTIVE LOCATIONS.

## **ADDITIONAL NOTES**

The 2.38" pulley when combined with our 14% overdrive damper will result in a supercharger speed 23,000 RPM at 6,500 RPM engine speed. Based on LPE testing we do not recommend exceeding 23,000 RPM on the LS9 supercharger.

The production GM LS9 fuel injectors and production fuel pump are able to supply the correct amount of fuel for either pulley size so no changes to the injectors or the fuel system are needed if you are only installing the Lingenfelter LS9 cover and supercharger pulley.

If you are using this pulley kit in combination with an overdrive damper and/or other engine modifications you may need larger injectors.

The production 2009-2013 ZR1 Corvette spark plugs are the same spark plugs used in the 2006-2013 Z06 Corvettes and the 2009-2013 CTS-V. In engine dynamometer, chassis dynamometer and track testing performed by LPE, we have found these spark plugs to be well suited to stock to highly modified LS9, LS7 and LSA engines. Unless you are running top speed testing or endurance type road racing applications or this is a marine engine application, LPE recommends retaining the stock LSA spark plugs at the production gap of 0.040" (1 mm). If you do find you need to go to a colder range spark plug, the production 12571165 (AC Delco 41-104) iridium spark plugs are roughly the same heat range as the Denso IT20 spark plugs and the NGK TR7ix spark plugs. The next stage in colder plugs would be a Denso IT22 or an NGK TR8ix.

# LINGENFELTER

## PERFORMANCE ENGINEERING

2009-2013 Chevrolet ZR1 Corvette and GMPP LS9 Crate Engine Pulley Chart												
Damper Size (OD%)	Damper Part # (1)	Supercharger Pulley Size (2)	Supercharger Pulley Part #	Belt Size	Belt PN	Passenger Side Idler	PS Idler Kit Part #	Driver Side Idler	DS Idler Kit Part #	Pulley ratio	Total OD%	SC speed @ 6600 RPM (3)
7.33" stock	OEM GM or L220550309	stock 3.1"	NA	stock 2137 mm (84.1")	12637321 (old # 12627521)	stock 76 mm	NA	stock 90 mm	NA	2.4	NA	15800
		2.6" (press on)	L220040309	stock 2137 mm (84.1")	12637321 (old # 12627521)	stock 76 mm	NA	100 mm	L250130309	2.8	19%	18500
		2.6" (10 bolt)	L220146109	stock 76 mm	stock 76 mm	NA	NA	76 mm	L250120309	3.1	32%	20500
8.34" 14% OD	L220100309	2.35" (10 bolt)	L220136109	82.5 inch	K110825	stock 76 mm	NA	stock 90 mm	NA	2.7	14%	17800
		stock 3.1"	NA	2185 mm (86.0")	11PK2185	stock 76 mm	NA	stock 90 mm	NA	3.2	36%	21100
		2.6" (press on)	L220040309	2160 mm (85.0")	11PK2160	stock 76 mm	NA	stock 90 mm	NA	3.6	50%	23800
		2.6" (10 bolt)	L220146109			stock 76 mm						
		2.35" (10 bolt)	L220136109	stock 2137 mm (84.1")	12637321 (old # 12627521)	stock 76 mm	NA	76 mm	L250120309			

LPE does not recommend supercharger speeds significantly past 23,000 RPM, especially in road racing and other high RPM durability type applications. To calculate supercharger speed, multiply your maximum engine speed by the pulley ratio value listed above.
2.35" pulley requires the stock GM supercharger front cover to be modified for pulley clearance. The high flow LPE LS9 front cover (L250110309) is already designed with clearance for the 2.35" pulley.
An LPE idler pulley kit is required for these pulley/belt combinations.

### NOTES:

1. Wet sump OEM diameter (L220396197) and overdrive (L220406197) versions of the LS9 torsional dampers are also available for applications running the LS9 supercharger and accessory drive on a wet sump engine.
2. 10 bolt (two piece) supercharger pulleys require a 10 bolt hub kit (L250150309) be installed on the supercharger. The LPE LS9 supercharger front cover (L250110309) already has a 10 bolt pulley hub installed.
3. OEM RPM limiter is set at 6600 RPM on the ZR1 Corvette.

Many other items are available from LPE for your ZR1 Corvette including low temperature thermostats, camshafts, ported throttle bodies and much more. Contact LPE, visit our web site, or contact your LPE distributor for information about our other products.

**For additional product installation information and technical support, contact LPE or your LPE products distributor. You can also find technical support and usage discussions regarding this product and many other LPE products in our Internet forums:**

**<http://www.lingenfelter.com/LPEforumfiles>**



Lingenfelter Performance Engineering  
1557 Winchester Road  
Decatur, IN 46733  
(260) 724-2552  
(260) 724-0422 fax  
[www.lingenfelter.com](http://www.lingenfelter.com)

L250110309 2009-2013 ZR1 Lingenfelter LS9 Supercharger Front Cover v2.3.indd