

## E90 MEGA MANTIS ANGLE KIT

\*Always use certified licensed technician/s for installation

### Introduction:

- This kit will fit BMW E90/E91/E92.
- Drift car angle kit is designed to increase the steering angle of the front wheels, allowing for greater maneuverability during drifting. It helps the car achieve higher steering angles and smoother transitions, essential for drifting techniques.
- Tools and equipment required for installation:  
Floor Jack, Jack Stands, Wrenches, Sockets, Plier, Torque Wrench, Thread Locker

### Step 1: Preparation

- Ensure the car is parked on a level surface and the wheels are chocked to prevent accidental movement during installation.
- Safety First - Disconnect the negative terminal of the battery to avoid any electrical accidents while working on the car. In addition to chocking the wheels and disconnecting the battery, it is essential to wear appropriate safety gear and clothing, including closed-toe shoes, long sleeves and safety glasses.
- Lift the car using a jack or Hoist making sure to position it securely under the recommended lifting points. Then, place the jack stands for additional support before beginning any work. Double-check that the car is stable and won't shift while you work.

### Step 2: Front Suspension removal

- Remove the wheels, brakes, and any components obstructing access to the front suspension.
- Unbolt the factory suspension components, such as tie rods and control arms. Be cautious not to damage any surrounding parts during this process.

### Step 3: Angle Kit Installation

Fully assembled view of FDF Mega Mantis Angle Kit for BMW E90/E91/E92 is shown for the right-hand side of the car.

1. RH Side Caster Plate Sub-assy.
2. RH Side Lower Control Arm Sub-assy.
3. RH Side Knuckle Sub-assy.

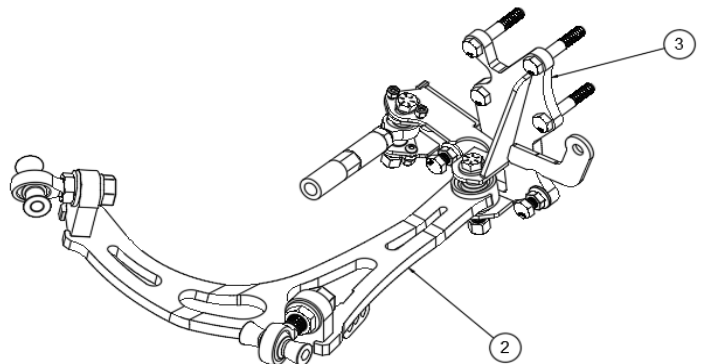
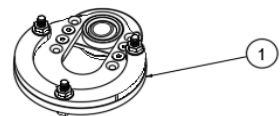

## Installing the Caster Plates

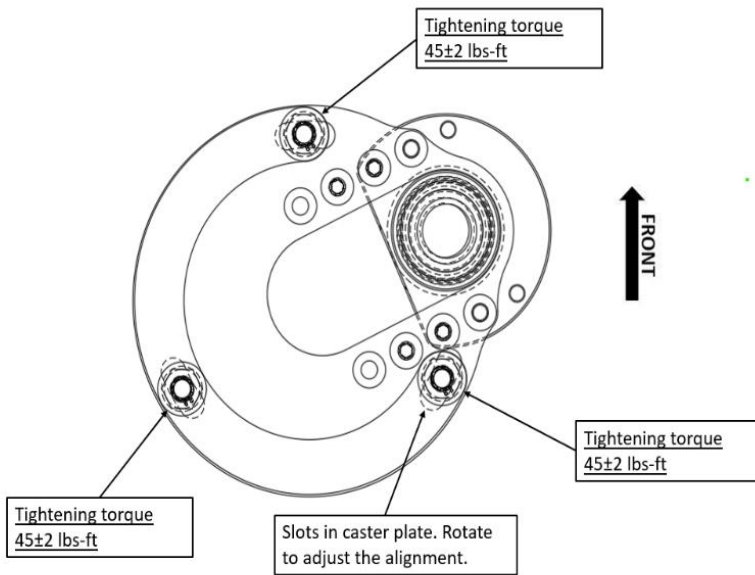

FDF Mega Mantis Caster plates for BMW E90/E91/E92 are different for Left-hand and Right-hand side of the car. The caster plate shown in the image is for Right-hand side of the car.

- The Caster plate comes with 3/8" spacer. This helps in easy installation preventing the interference between caster plate and chassis.
- The Caster plate bearing will come pre-assembled. Make sure that the bearing is mounted from the bottom during fitment.
- Make sure all the bolts are torqued properly.

## Installing the Lower Control Arm

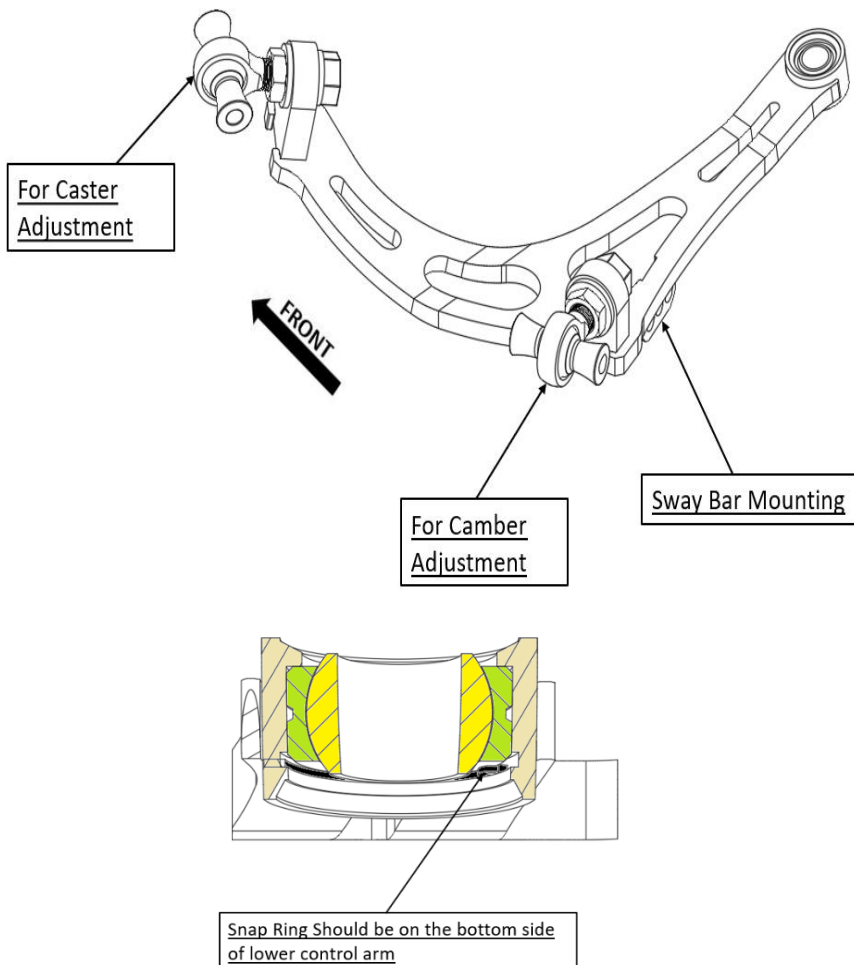

FDF Mega Mantis Lower Control Arm for BMW E90/E91/E92 is different for Left-hand and Right-hand side of the car. The Lower Control Arm shown in the image is for Right-hand side of the car.

- The Spacers will be zip-tied to the Heim Joints before shipping. Make sure to assemble the spacers in the car in the correct orientation.
- The Snap ring will go from the bottom side of the lower control arm.
- Make sure all the bolts are torqued properly.



## Installing the Knuckle

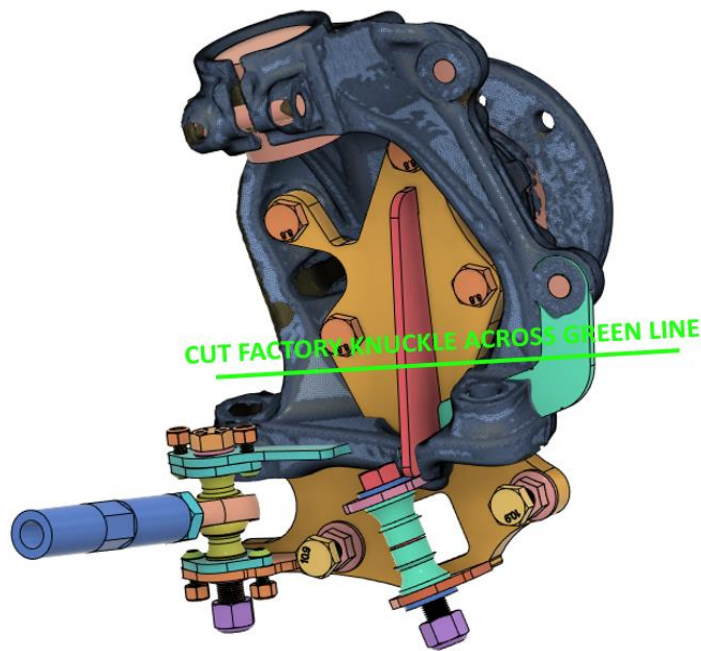

Cutting and Grinding the Factory Knuckle: The factory knuckle needs to be cut along the green line, just below the bearing bolt holes. The knuckle will also need some radiused corners on the casting flattened with a grinder, to make sure the adaptor sits flat to the knuckle before fastening.

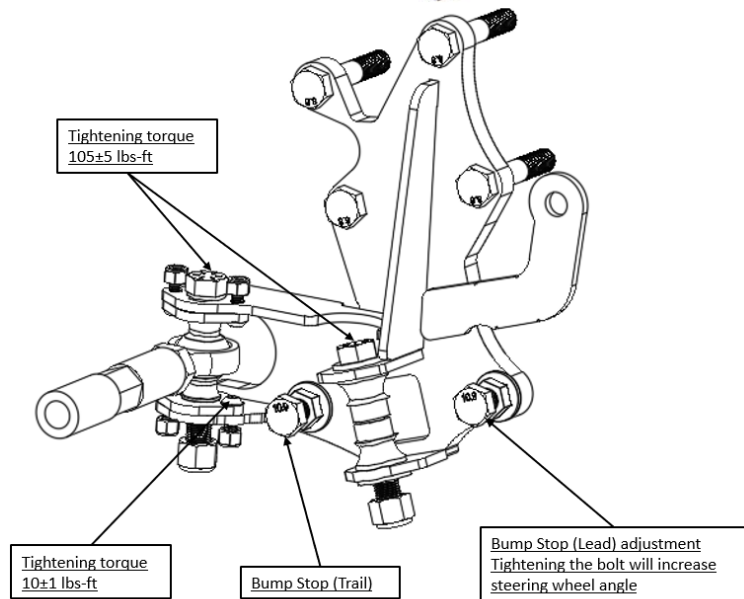

FDF Mega Mantis Knuckle for BMW E90/E91/E92 is different for Left-hand and Right-hand side of the car. The Knuckle shown in the image is for Right-hand side of the car.

- Make sure all the bolts are torqued properly.
- While adjusting bump stop, make sure tie rod is not binding. Also, check for wheel clearance between car body and suspension components through the extent of suspension travel and limit the steering wheel angle to avoid any interference.

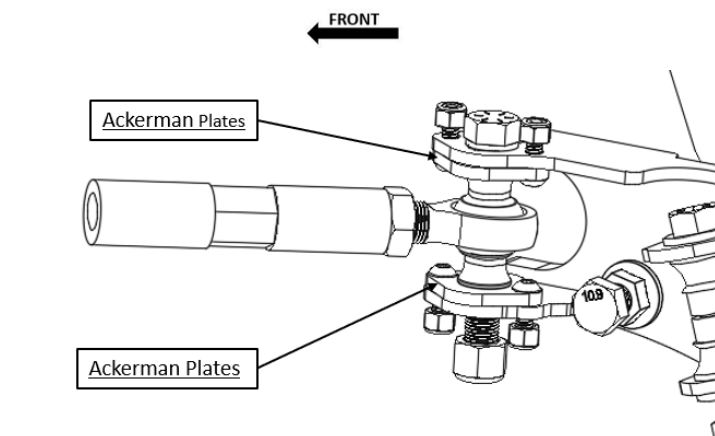

Adjusting the Ackermann: FDF Mega Mantis Angle kit comes with adjustable Ackermann Plates. The kit will come with zero Ackerman plates installed and include +2/-2 options that can be changed. Ackermann is the difference in angle measured at full lock.

Example: with 0 Ackermann plates installed, the angle of the car will be 60° on the lead wheel and 60° on the trailing wheel.

\*Please note that alignment settings, rack position and other variables can affect the Ackermann curve resulting in differences from chassis to chassis, make adjustments according to your individual setup.



#### **Step 4: Reassembly**

- Double-check all connections and fastenings for any loose or improperly secured components.
- Pay attention to every bolt and nut to prevent any potential issues during drifting.
- Reinstall the wheels and brakes. Ensure brake lines are of sufficient length while turning wheels both sides lock to lock (no tension or potential breaking).
- Lower the car back to the ground.

#### **Step 5: Alignment and Adjustment**

Recommended Alignment Specifications: -

- Caster +6.5° to +7.5°
- Camber -3.5° to -4°
- Toe 0 to 1/8<sup>th</sup> out
- Wheel size recommendation 18 x 9 +15 offset

These are only the recommended alignment specs. You can set up based upon individual preference.

- Do not exceed the Heim joint adjustments. Each Heim joint should have a minimum of 1 to 1.5 times the diameter of the Heim joint. (For Example: a 3/4" Heim joint needs to have approx. 3/4" to 1 1/8" thread engagement inside the arm, this is 12-18 threads)
- After installing the angle kit, it is crucial to get a professional alignment at a specialized shop that understands drifting setups. They will align the car to optimal angles for drifting and ensure the best possible handling and response.
- Additionally, adjustments to the angle kit components might be necessary to fine-tune the car's steering and suspension to your preferred drifting style. Make these adjustments as needed while considering safety and performance.

#### **Step 6: Test Drive**

- Before fully utilizing the drift car, take it for a test drive in a safe area to assess how it responds to the angle kit installation. Pay attention to any issues, unusual noises, or handling quirks that may require further adjustments.
- Take notes of any issues and adjustments needed during the test drive. Address these concerns before engaging in more aggressive drifting maneuvers.

#### **Conclusion:**

Recap the installation process and emphasize the importance of professional alignment after installing an angle kit. Always remember to prioritize safety during any car modifications and always use certified licensed technician for your installations. Bolt check regularly, recommendation is before each racing event.

Thank you for choosing FDF angle kit to enhance your drifting experience.

Stay connected with FDF Raceshop for new product releases.

Follow us on Facebook, Instagram and YouTube

 <https://www.facebook.com/fdfaceshop/>

 <https://www.instagram.com/fdfaceshop/>

 <https://www.youtube.com/@FDFaceshop>

