

Installation Guide

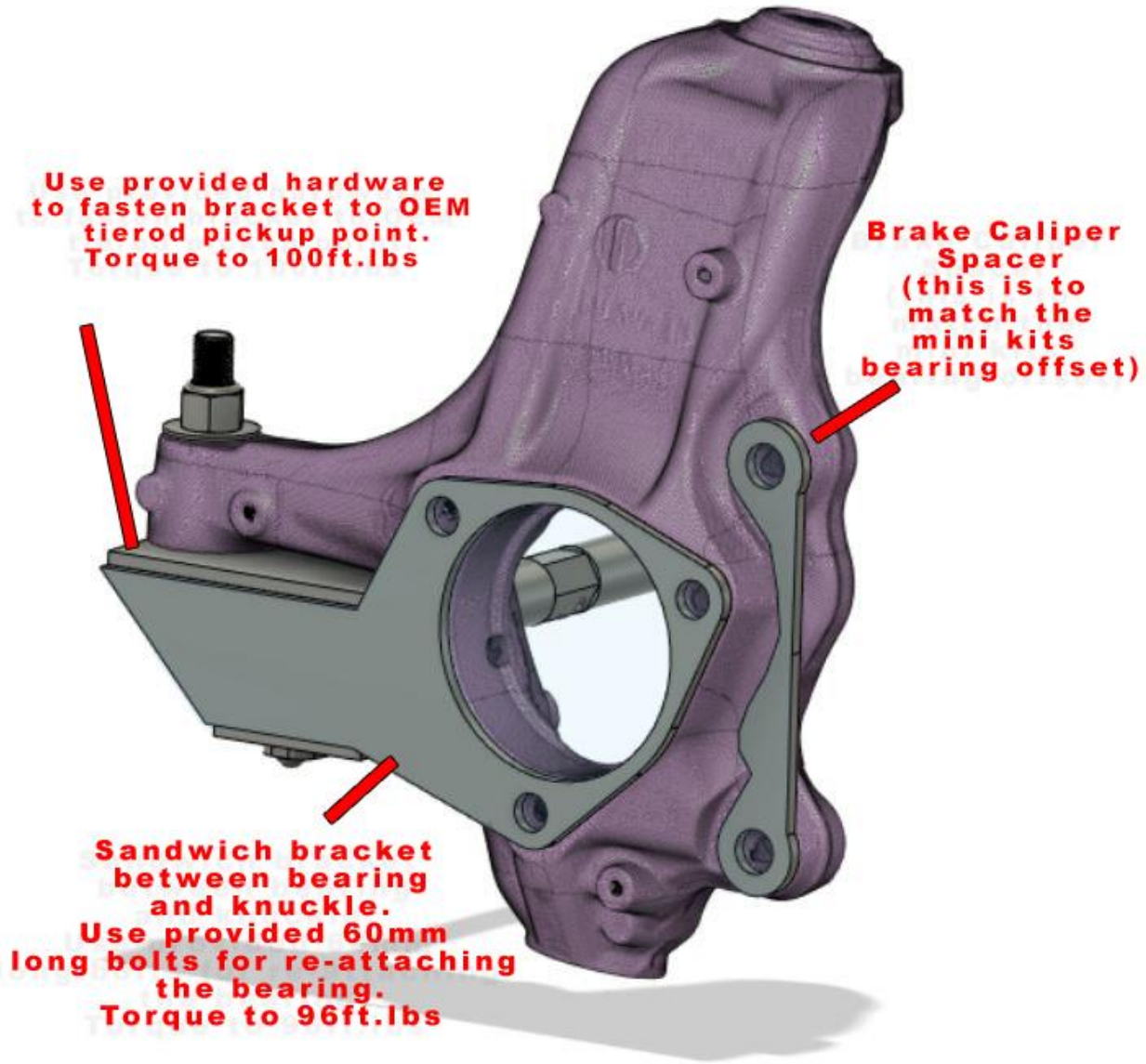

For Racing Use only



Not For Road Use

Must be installed by a licensed professional



fdfraceshopcustomerservice@gmail.com
+1(613)243-8859

Installation Guide

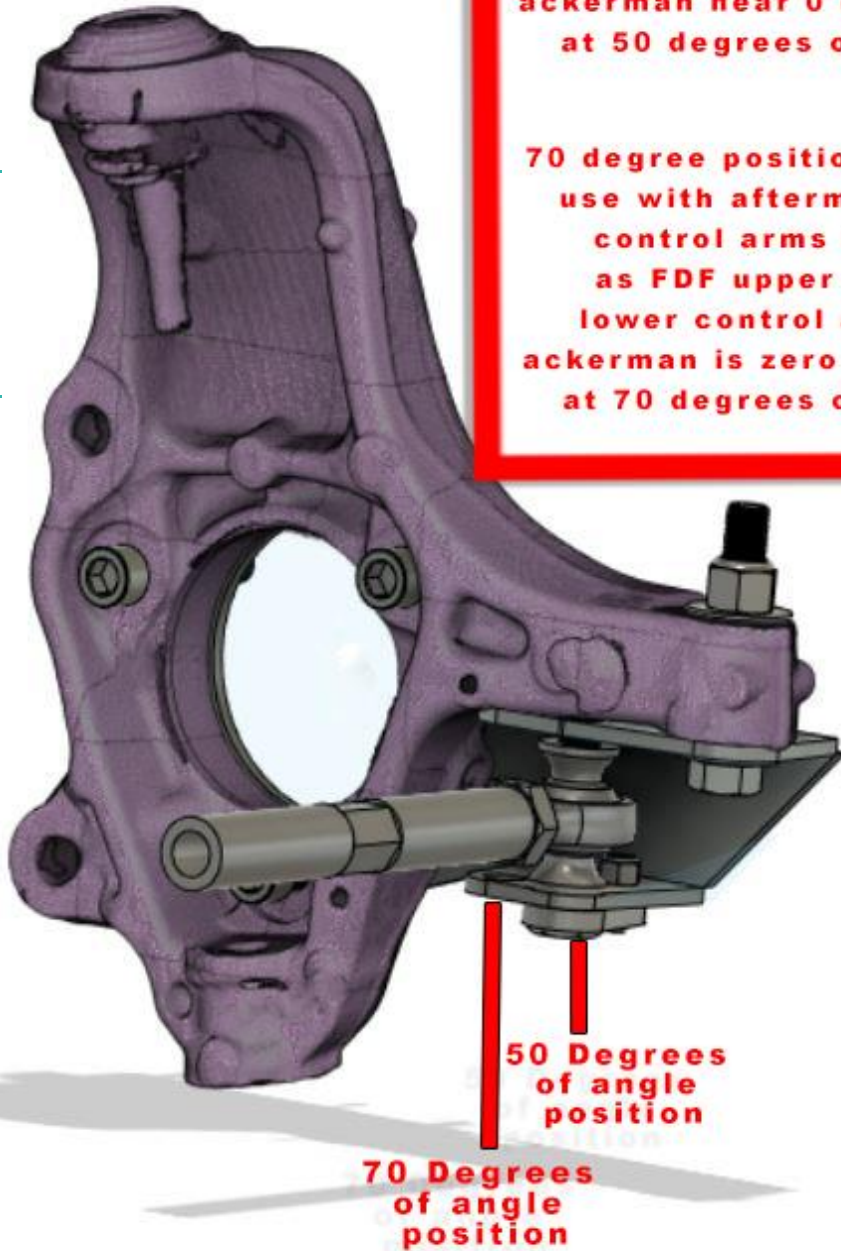

50 Degree position recommended
use with oem components,
ackerman near 0 degrees,
at 50 degrees of lock

70 degree position is for use with aftermarket control arms such as FDF upper and lower control arms, ackerman is zero degrees at 70 degrees of lock

C7 Corvette

Alignment Recommendations

Aftermarket Control Arms
-4 camber,
7 degrees of caster
.2 degrees toe out
or 1/8"

OEM arms
7 degrees of caster
lower camber possible
.2 degrees toe out
or 1/8"

For Racing Use only



Not For Road Use

Must be installed by a licensed professional



fdfraceshopcustomerservice@gmail.com
+1(613)243-8859

PARTS LIST		
ITEM	QTY	PART NAME
1	1	1/2-20X3 BOLT
2	2	1/2 WASHER
3	1	1/2-20 NYLOCKNUT
4	1	5/8-18LH HEIM JOINT
5	2	5/8 HEIM SPACER
6	1	6.5 TIEROD
7	1	5/8-18 JAMNUT
8	1	1/2-20 X2.5 BOLT
9	1	LOCKING PLATE
10	1	1/4-20 SS BUTTON BOLT
11	1	1/4-20 NYLOCK NUT
12	3	M12X1.75 - 60MM BOLT
13	1	CALIPER SPACER
14	1	TIEROD ADAPTOR BRACKET

