

Model #	CL-2880-MB
SKU	18608
Description	Medium Coach Light
Finish	Matte Black
Glass	Clear
Dimensions- HxW (Dimensions shown in inches)	17.625" x 9"
Lamp Info	1X60W (M)

Finish/Glass Shown: Textured Black/Clear

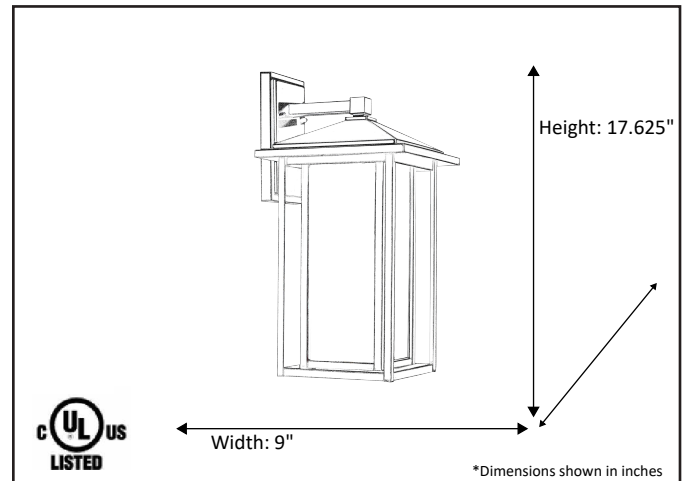

*Lamps not included



ELECTRICAL REQUIREMENTS: Fixture requires a grounded electrical supply line of 120 volts AC.

INSTALLATION REQUIREMENTS: Fixture attaches to electrical junction box securely anchored in wall or ceiling.
All mounting hardware included.

Vivio Lighting/ 1503 Kelly Blvd., Carrollton, TX. 75006

Product specifications subject to change without notice.

REFERENCE	QTY.	REMARKS	Project
			Location/Type
			Architect
			Engineer
			Contractor
			Submitted By: Date: