

# MOBEL MAXIM CONFERENCE TABLE

## Assembly Instructions









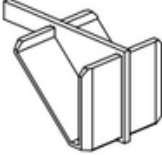
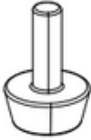

Thank you for your purchase

Please follow the instructions for correct assembly



## Hardware Supplied

Below parts may vary on size of table:

 A 120° Bracket * 8Pcs	 B 90° Bracket * 12pcs	 C 180° Bracket * 2pcs	 D Adjustable Glide M6*22 * 12pcs
 E 120° Trim Strip * 4pcs	 F Cam Lock * 8 Pcs	 G Klix Cam * 8 Pcs	 H Dowel Ø8x40 *24 Pcs
 I Sticker * 8 Pcs	 J Screw ST5x16 * 36Pcs	 K Screw ST4x25 * 6Pcs	 L Screw ST5x20 * 32Pcs

You will need a phillips screwdriver to assemble this unit

Below parts and instructions will vary slightly depending on size of table

mobel

1

# Step 1

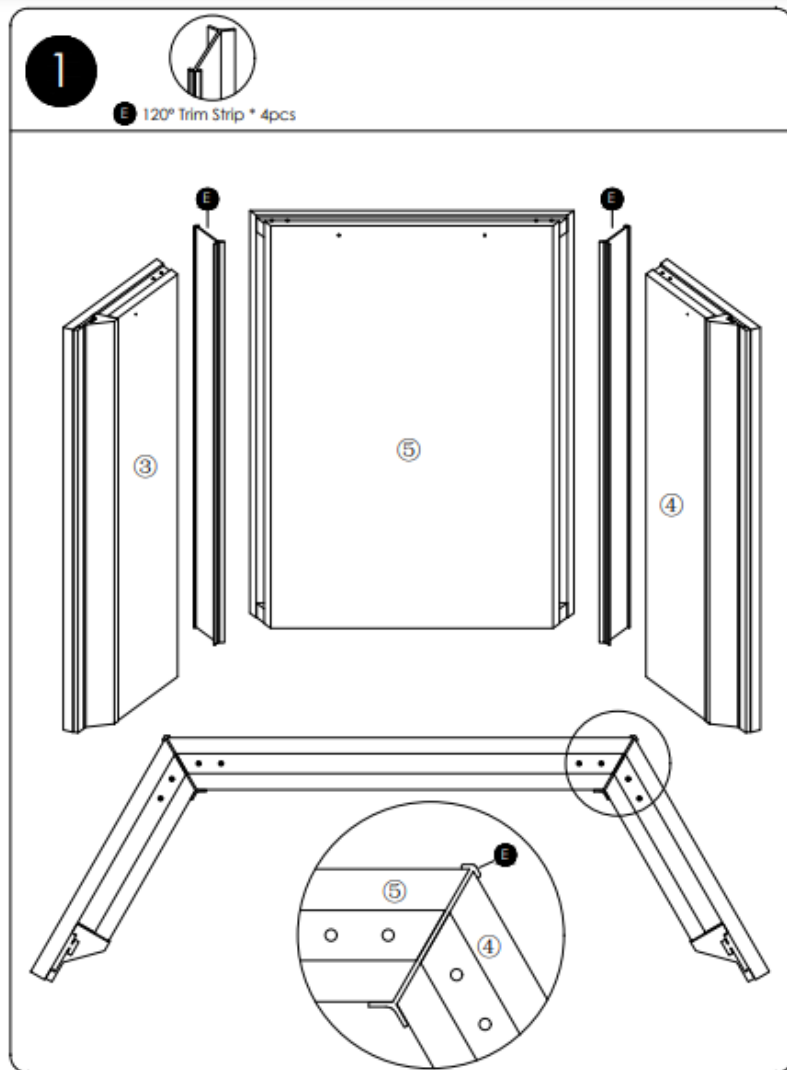

# Step 2

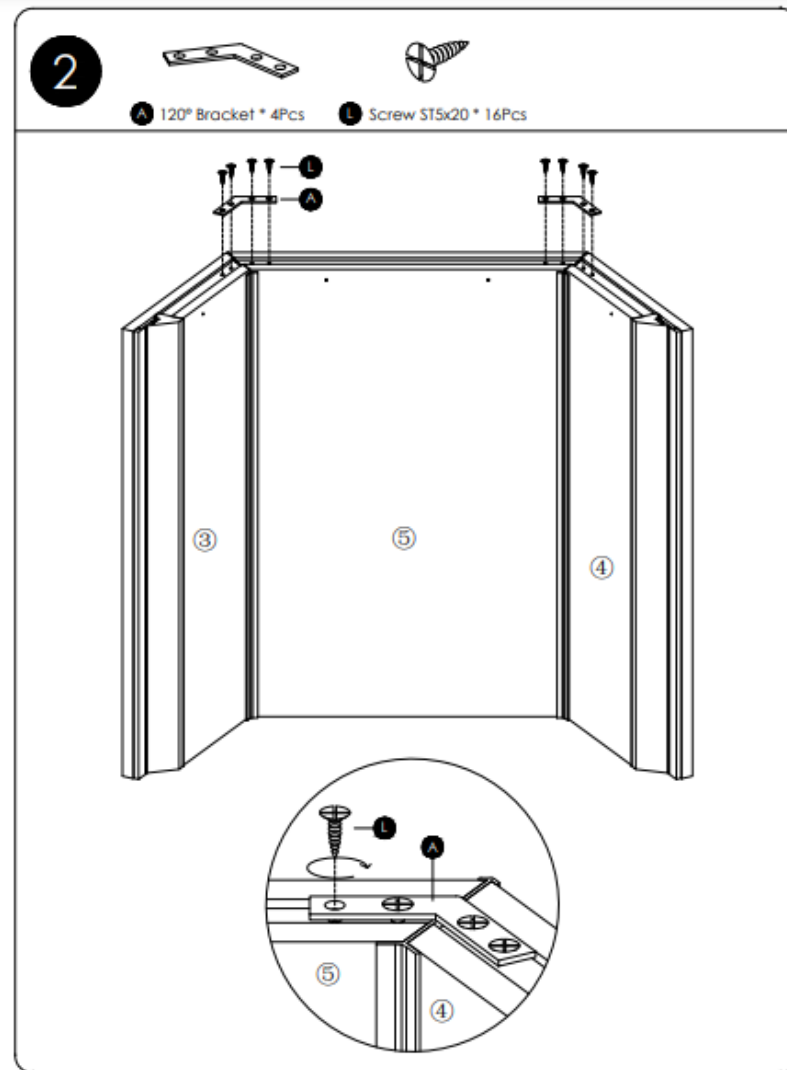

### Step 3

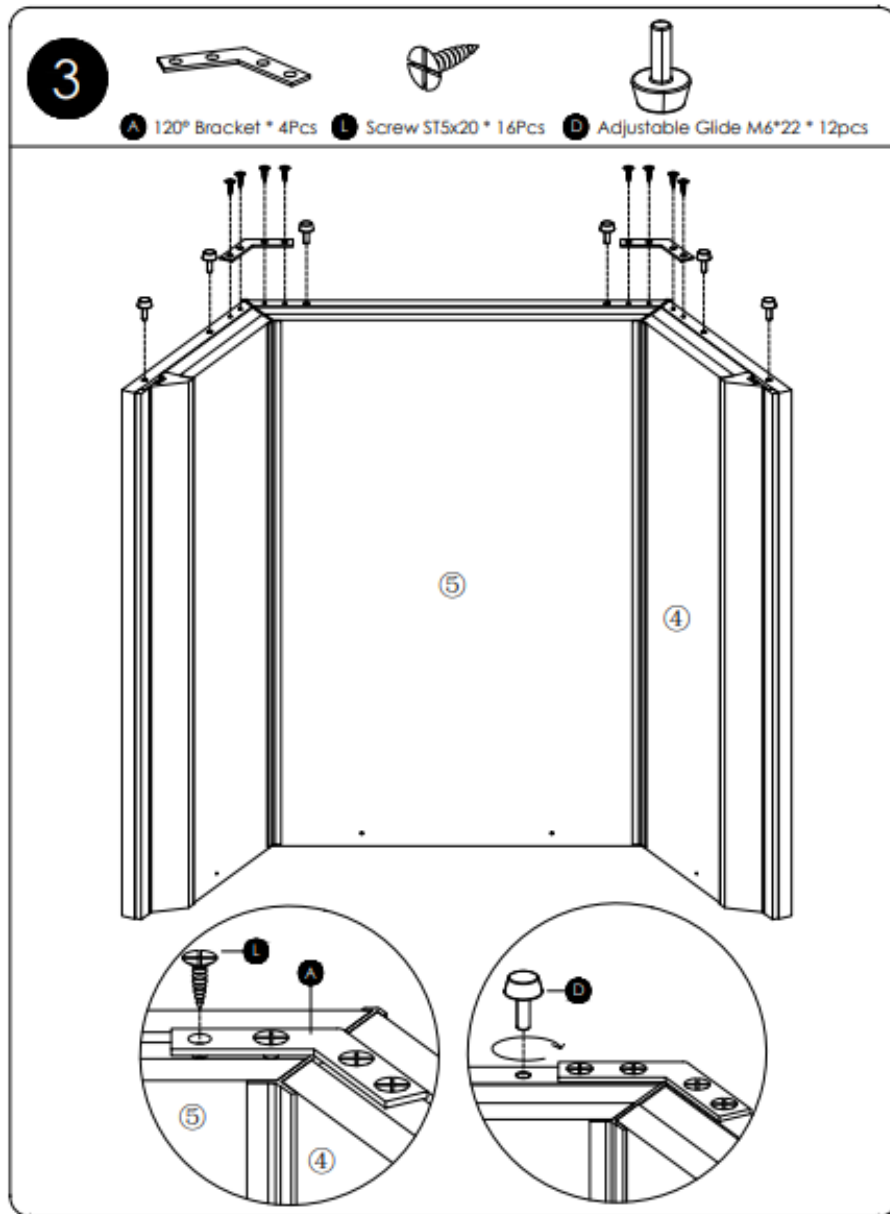

### Step 4

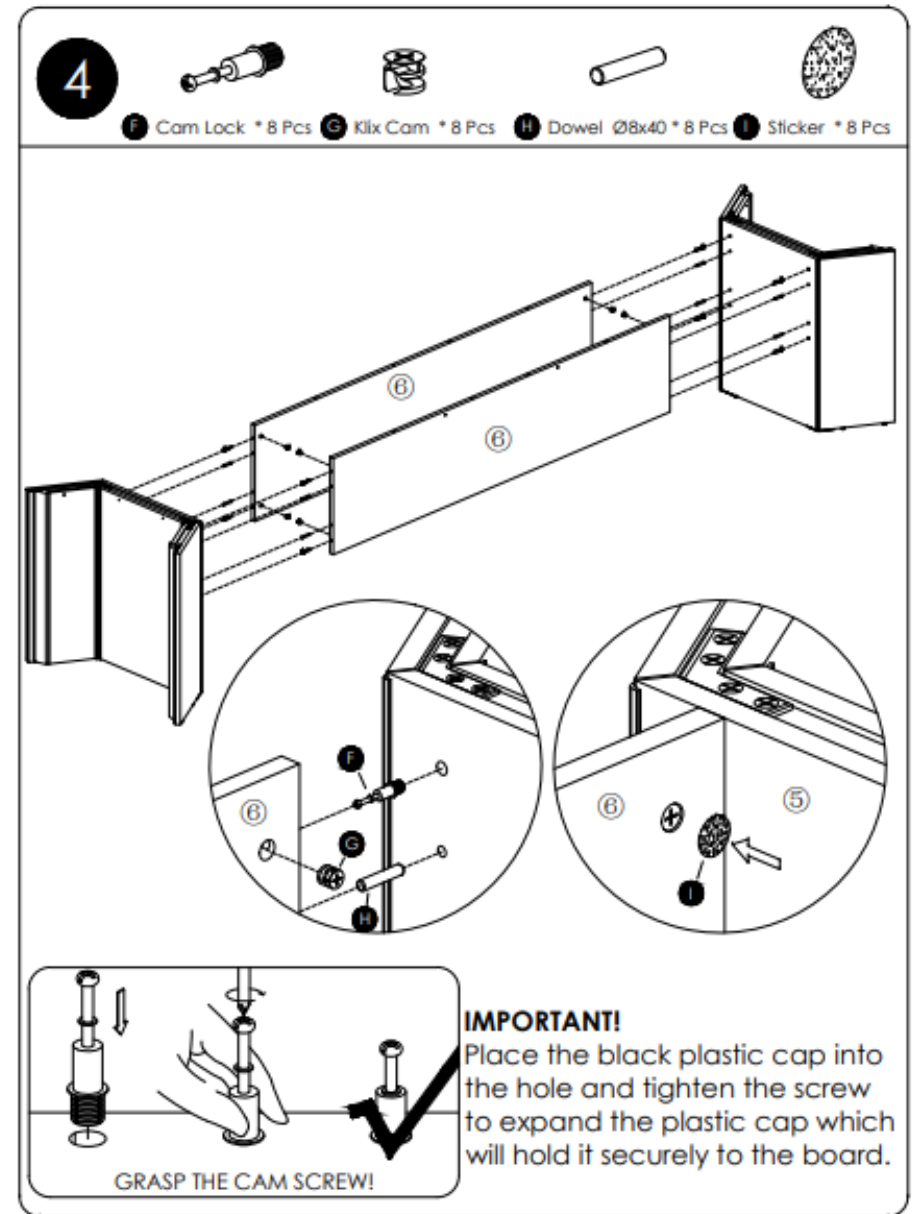

## Step 5

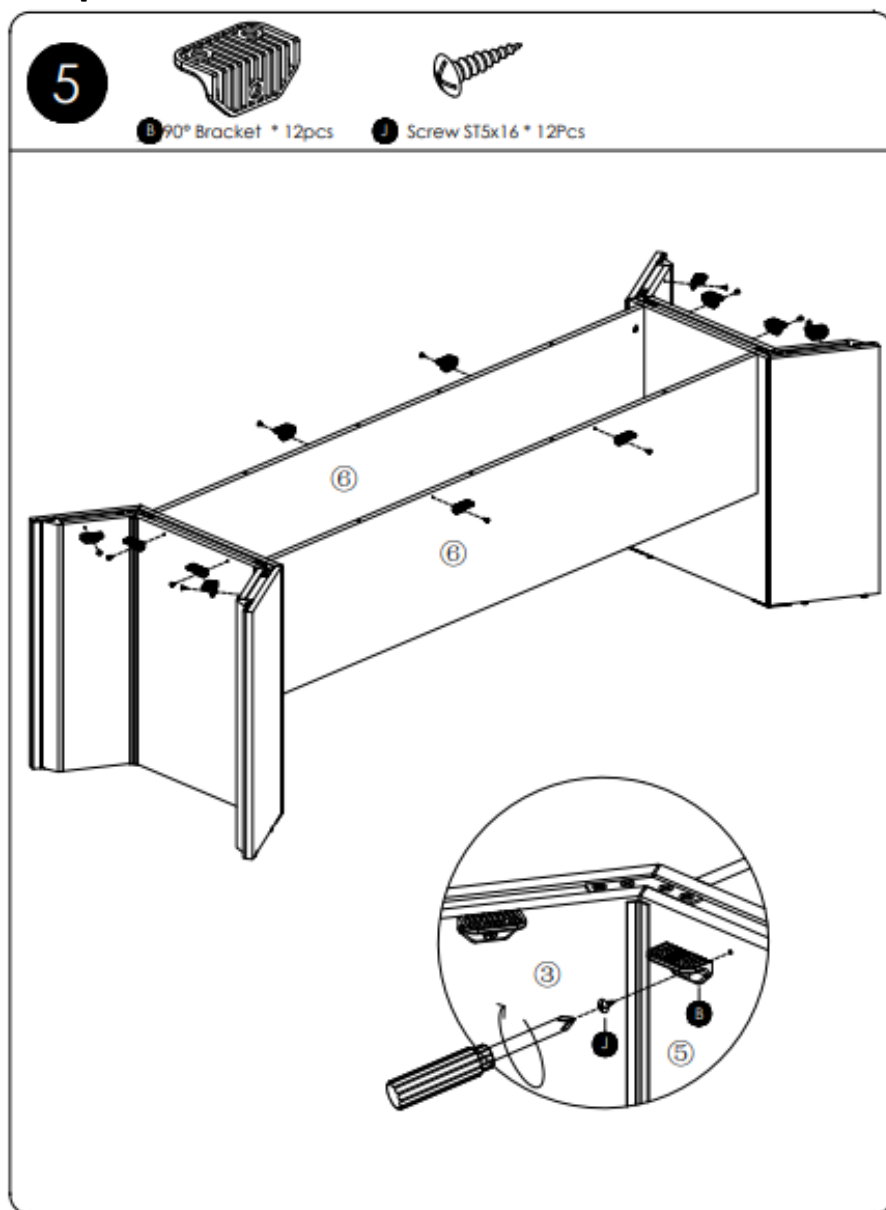

## Step 6

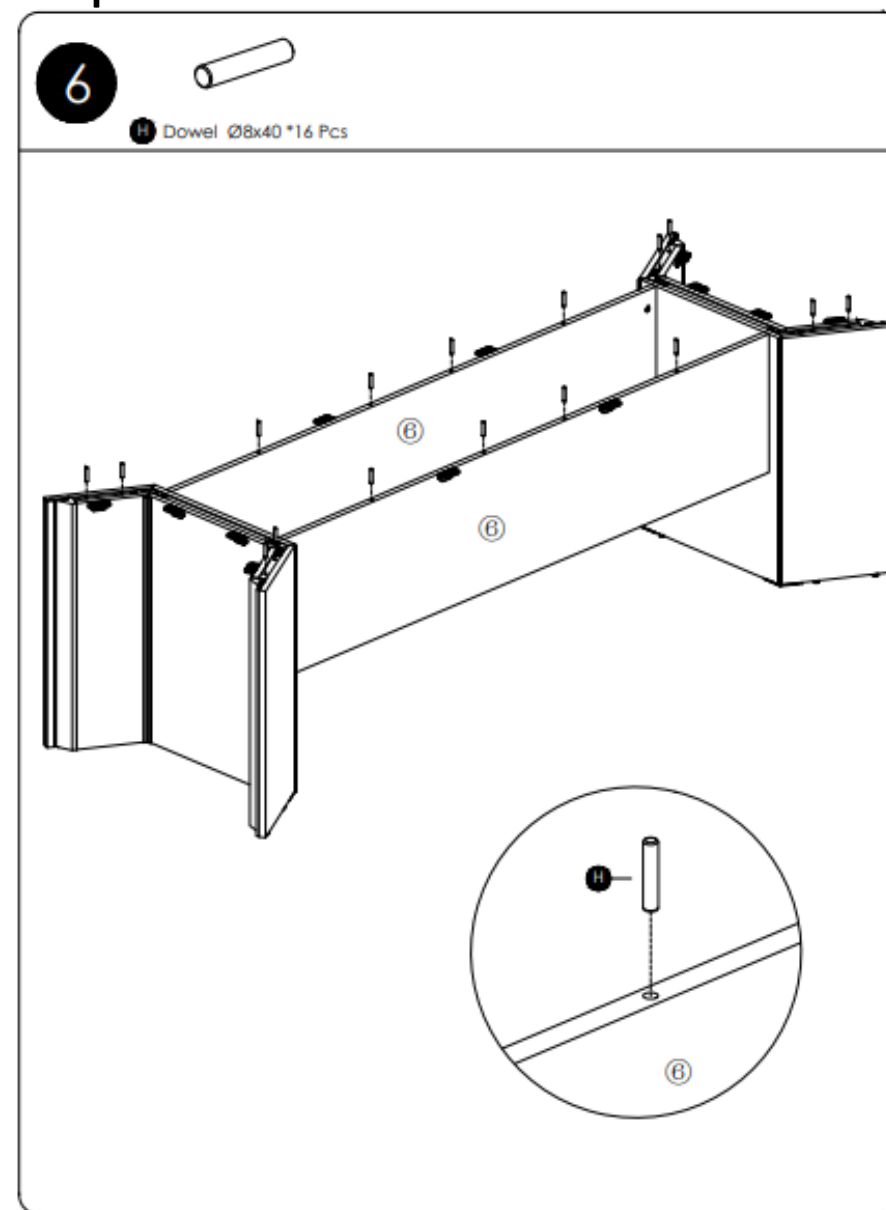

### Step 7

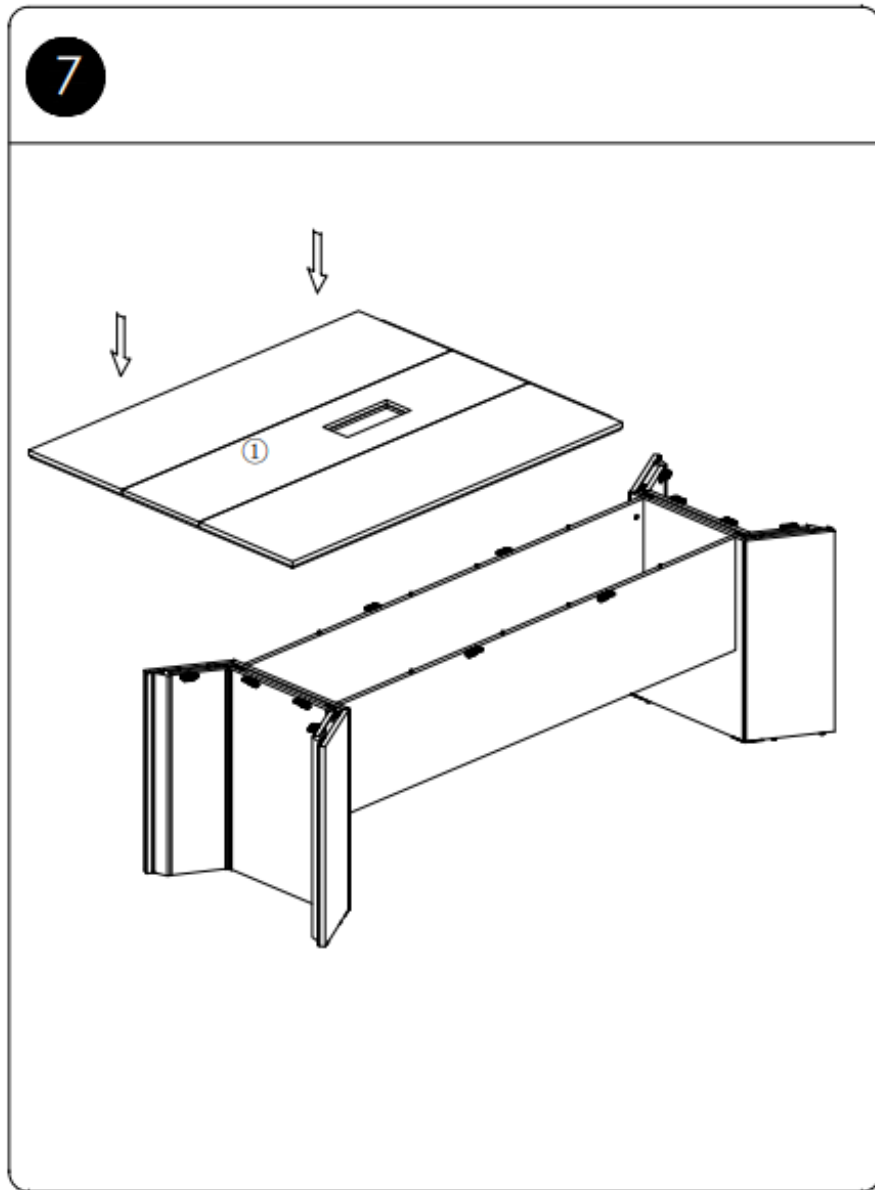

### Step 8

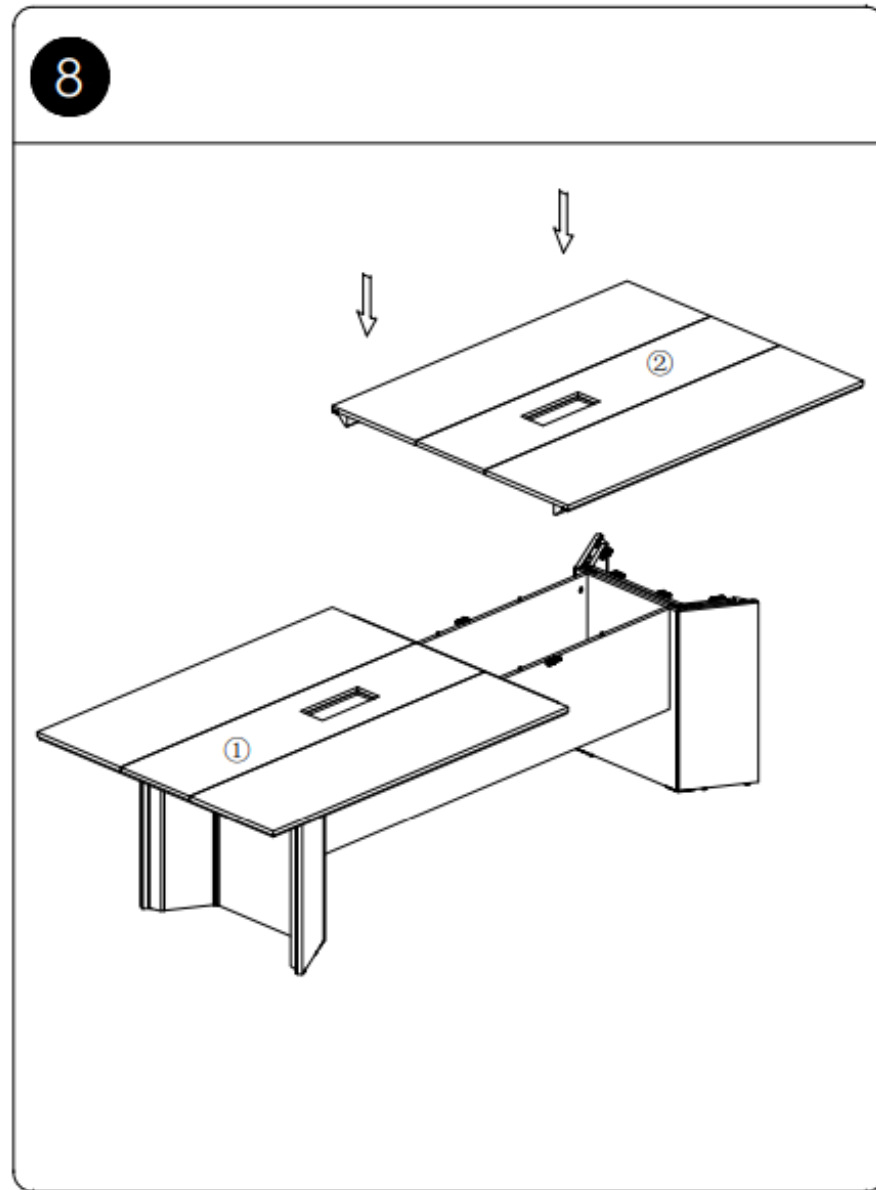

## Step 9

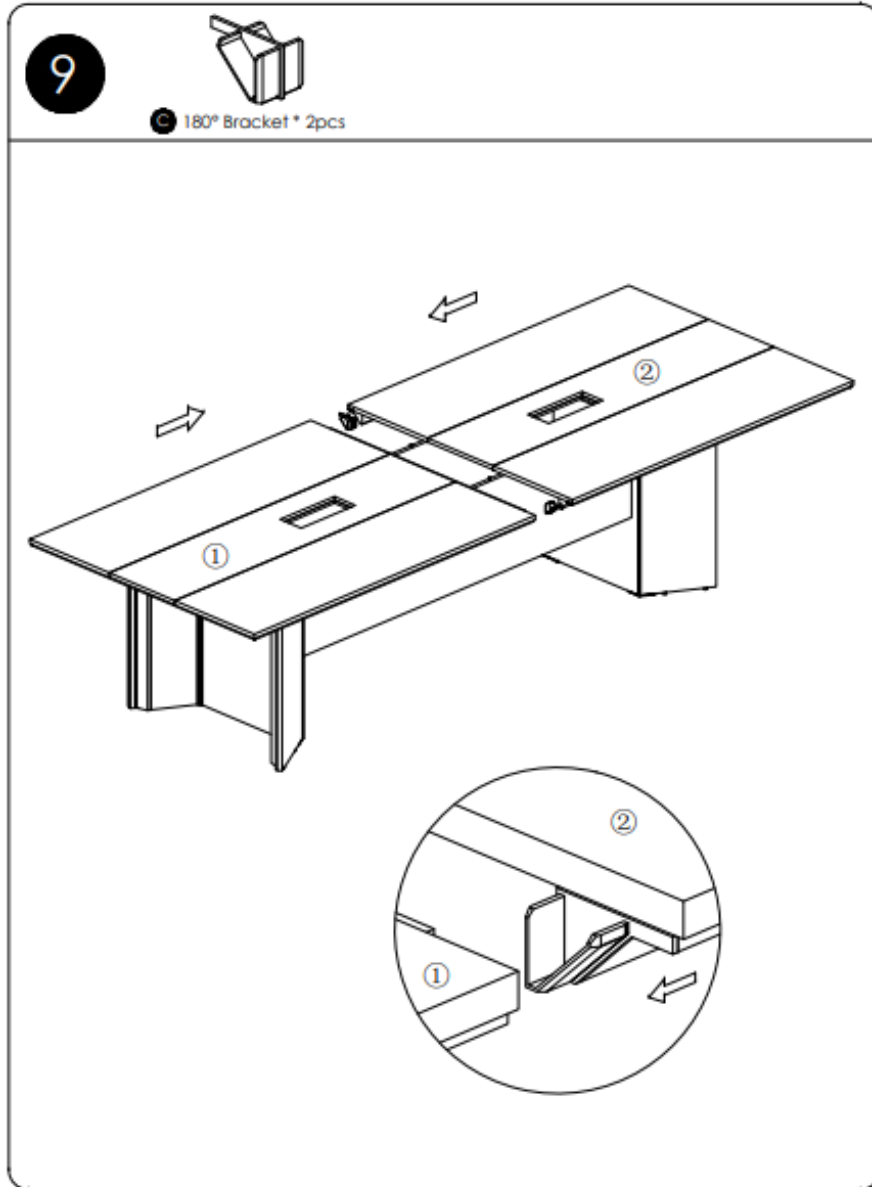

## Step 10

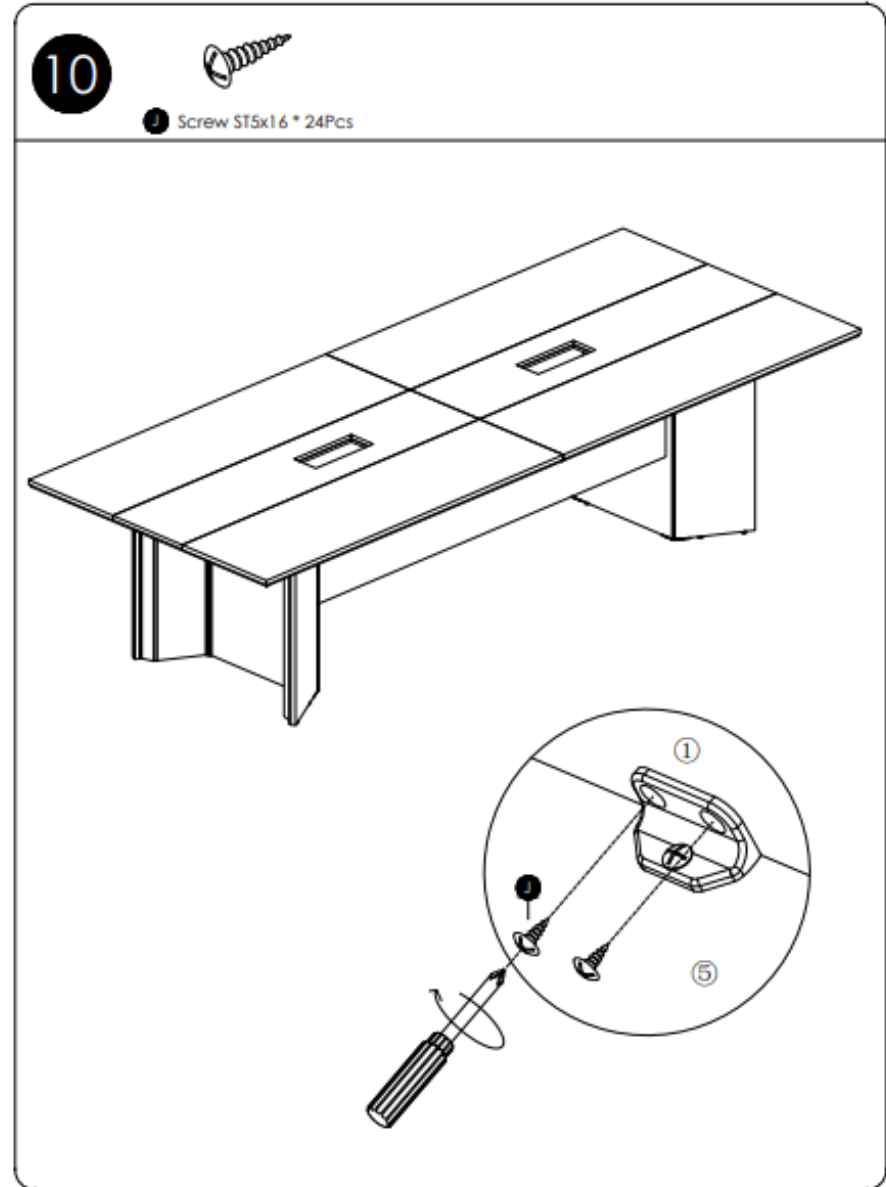

## Step 11

11



• Screw ST4x25 \* 6Pcs

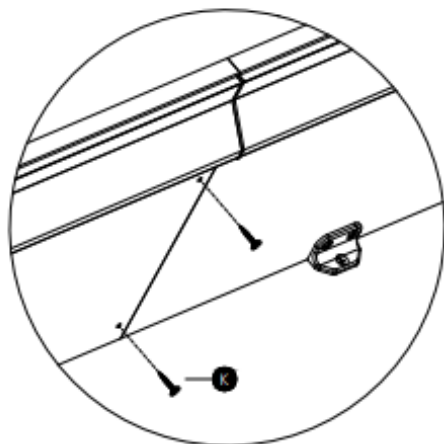
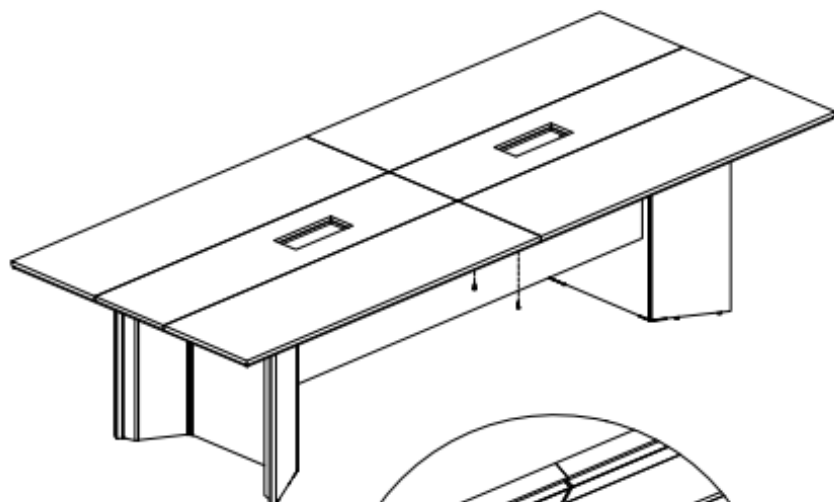

## Step 12

12

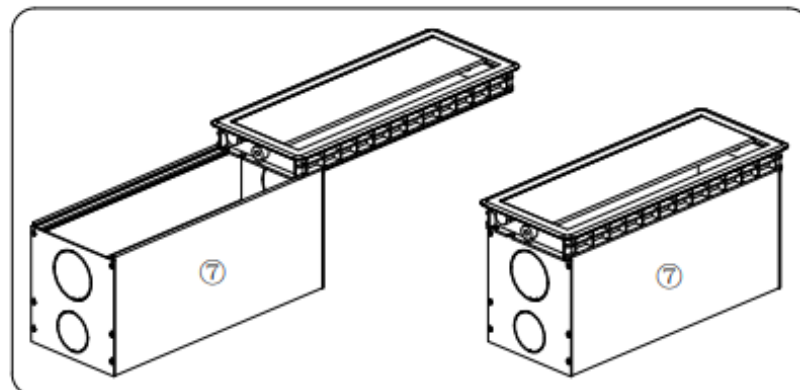
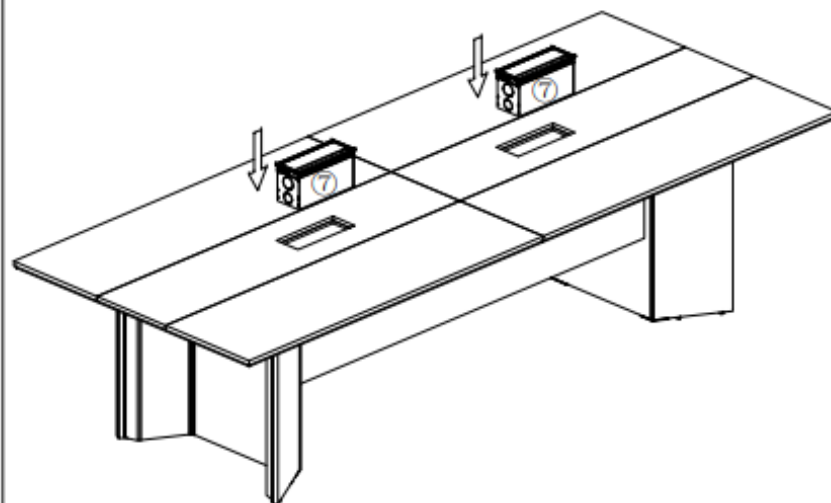

Step 13

13

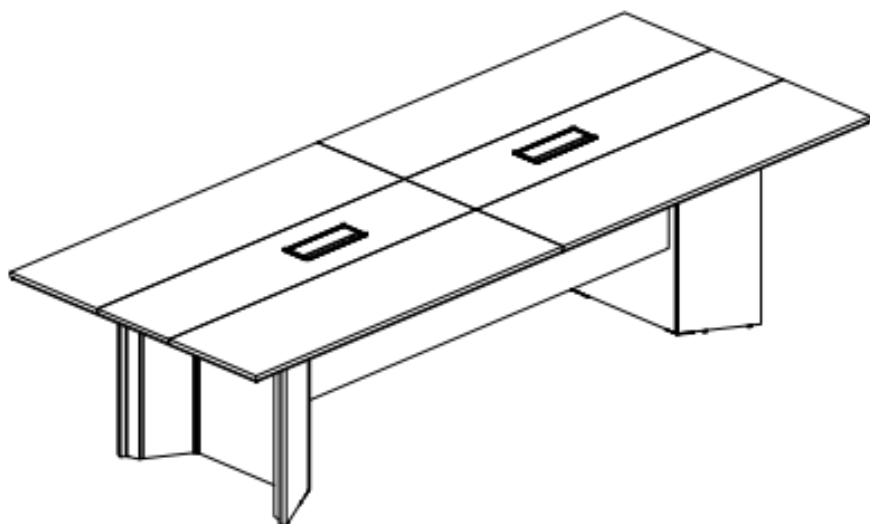

COMPLETED ASSEMBLY