

Measurement & Spectroscopy



All-in-One laser

Raman Spectroscopy
Brillouin Scattering
Interferometry
Photoluminescence
Holography
Laser Doppler Velocimetry
Laser Ultrasonic
Dynamic Light Scattering

LaserBoxx

One platform for all colors

SLM CW Monolithic DPSS benefits

- Up to 500 mW
- Exceptional wavelength stability - 1pm
- Lowest power consumption
 - ▶ ≤ 12 W for LCX's & LPX's, any wavelength, less than 200 mW
 - ▶ ≤ 15 W for LCX-532 & LCX-1064, 500 mW
 - ▶ ≤ 15 W for LCX-561 300 mW
 - ▶ ≤ 15 W LPX-640, 250 mW
- Low profile laser head (32 mm)
- Tailored beam diameter capability (0.6 up to 1.4 mm)

VBG stabilized Laser Diode modules benefits

- Proprietary SLM locking routine
- Enhanced beam quality versions

Common key features

- Single Longitudinal mode
- TEM₀₀ Beam
- Beam pointing ≤ 5 μm/°C
- SM/PM/MM fiber coupling options
- USB and RS232 computer interface
- Graphic User Interface with remote diagnostics
- Remote *ControlBoxx* with power display (Plug&Play versions - CDRH)
- Controllers integrated into laser head
- LBX and LCX - Industry standard footprint (100 x 40 mm²)

532

553

561

633

640

785

830

1064

Specifications

Single Frequency Lasers

	LCX-532S	LCX-553S	LCX-561S	LPX-640S	LCX-1064S	LBX-633S	LSX-785S-ISO	LBX-830S
Technology	DPSS					Stabilized laser diode		
Optical characteristics								
Emission wavelengths	532.3 nm ± 0.3 nm ⁽¹⁾	553.0 nm ± 0.4 nm	561.4 nm ± 0.4 nm ⁽¹⁾	639.6 nm ± 0.4 nm	1064.6 nm ± 0.5 nm	632.5 nm ± 0.5 nm	785 nm ± 0.5 nm	830 nm
Wavelength Stability over 8 hours and ±3°K	≤ 1 pm					≤ 10 pm ± 0.5 nm		
Linewidth	≤ 1 MHz					≤ 100 MHz typ.		
Coherence Length	≥ 100 m					≥ 1 m typ.		
Nominal output power, continuous wave	50 mW to 500 mW	50 mW to 200 mW	100 mW to 300 mW	50,100, 250 mW	100 mW to 500 mW	40 mW	150 mW with isolator	100 mW
Control mode	Automatic power control (APC)					Automatic current control (ACC)		
Power stability over 8 hours and ±3°K	± 1%							
Option Power Adjustment	30-100%	50-100%	30-100%	30-100%	30-100%	Optional L1C MPA		
Optical noise % RMS, 10Hz - 20MHz bandwidth	≤ 0.2%							
Transverse singlemode free-space beam (*)								
Beam waist diameter (typ.) at 1/e ² , 50mm from output aperture	0.7 ± 0.1 mm					0.5 to 1.0 mm	0.5 ± 0.1 mm	0.5 to 1.0 mm
Beam divergence at 1/e ² , full angle, in far field	1.0 ± 0.2 mrad				2.0 ± 0.4 mrad	2 to 4 mrad	≤ 1.7 mrad	2 to 4 mrad
Beam quality factor (M ²)	≤ 1.1					≤ 1.9	≤ 1.25	≤ 1.9
Beam circularity in far field	≥ 90%					≥ 65%	≥ 90%	≥ 65%
Beam pointing stability	≤ 5 μrad/°K							
Polarization state	linear, vertical							
Polarization extinction ratio (typ.)	1000:1					100:1		
PM fiber coupling option (*)								
Nominal output power	35 mW to 350 mW	35 mW to 140 mW	35 mW to 210 mW	70 mW to 175 mW	35 mW to 350 mW	20 mW	105 mW	40 mW

(1) ± 0.5 nm at 500 mW
* Specifications at nominal power
Other available wavelengths: 405 nm, 946 nm

System Specifications			
Version	LCX, LPX, LSX, LBX-S	LCX and LPX	LSX and LBX-S
CDRH compliance	Yes	No	
Device qualification	Plug and play	OEM	OEM
Operating temperature	10 - 30 °C (ambient)	10 - 50 °C (baseplate)	20 - 35 °C (baseplate)
Power Consumption	≤ 25 W	≤ 20 W	≤ 10 W
Storage temperature	0 - 60 °C		
Supply voltage	100 - 240V AC external power supply	5 - 12V DC	
Warm-up time	≤ 10 minutes (LCX, LPX) / ≤ 2 minutes (LSX, LBX)		
Communication interfaces	USB, RS-232, dedicated I/O interface		
Laser head dimensions	see drawings	100 x 40 x 32 mm ³ (LCX) 120 x 40 x 32 mm ³ (LPX)	100 x 40 x 40 mm ³ (LBX-S) 120 x 40 x 40 mm ³ (LSX)
Laser head weight	≤ 600 g including heatsink	≤ 250 g	≤ 330 g
Electronic	integrated into laser head		
Controller Plug&Play			
Controller with Power adjustment	ControlBoxx	optional	
Controller fixed power	RemoteBoxx		

- ### Custom Capabilities
- Wavelength tunability up to 10 pm
 - Tighter wavelength selection
 - Custom wavelengths
 - Opto-mechanical Subassemblies including:
 - Wavelengths combiner (L2C, L4C, L6C)
 - AO modulator (see L1C datasheet)
 - Specific beam diameter or beam shaping
 - Custom control interface
 - Extended operational temperature range

Advanced features with L1C platform



The L1C platform offers an efficient, compact and cost effective solution to add advanced features to the LCX, LPX, LSX or LBX-S lasers:

- L1C-MPA – Motorized Power Attenuator
- L1C-AOM – Acousto-Optic Modulator – DC 3MHz
- L1C-ISO – ≥ 25dB Isolation and transmission ≥ 85%. It comes in standard with the electromechanical shutter.

Electro-Mechanical shutter option

The ACX-SHTE is a compact and affordable electro-mechanical shutter. It is mounted directly on the LCX or LPX in place of the standard manual shutter.



The fiber coupling and other options are fully compatible with the electro mechanical shutter. The ACX-SHTE is actuated via the LCX or LPX embedded software or via a standard TTL signal.

LCX & LPX - DPSS Monolithic Resonator

Technology
The unique feature of the LaserBoxx DPSS is a proprietary, Alignment-free Monolithic Resonator (AMR). The elements of resonator are assembled into a single ultra-low-loss optical subsystem, using a proprietary crystal bonding technique.

A highly transparent compound, deposited on chemically activated end-faces of two crystals, creates a bond that is extremely robust over time, temperature variations, and insensitive to mechanical vibrations. Dielectric mirrors coated at the end-faces of the crystals complete the monolithic assembly with no moving parts.



Benefits of the AMR
The OXXIUS AMR technology offer the highest spectral quality of the market and a high robustness over the time. The LCX & LPX lasers are insensitive to temperature variations and mechanical vibrations. High stability and reliability.

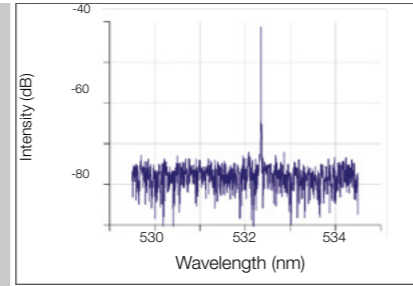

Single Longitudinal Mode LCX-532S spectrum

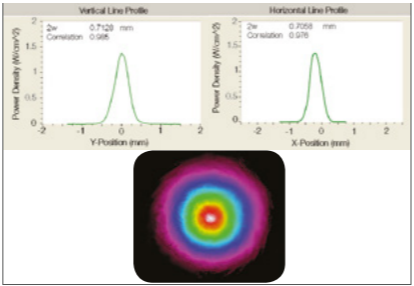

Beam Profile LCX-553S-200

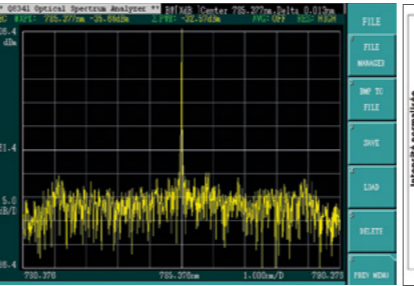

Single Longitudinal Mode LSX-785S spectrum

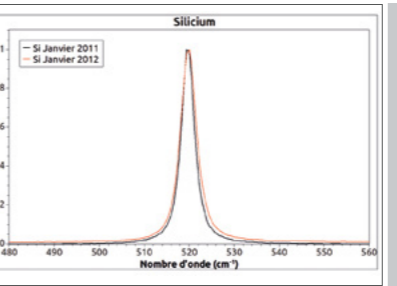

Si Raman Spectrum obtained with LSX-785S

Wavelength Stability LCX-561S wavelength vs time

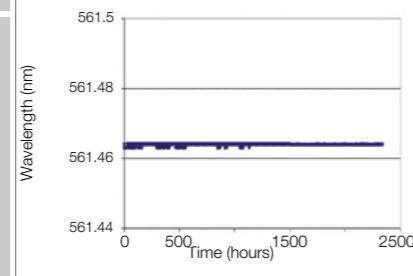

Power Stability LCX-561S power vs temperature

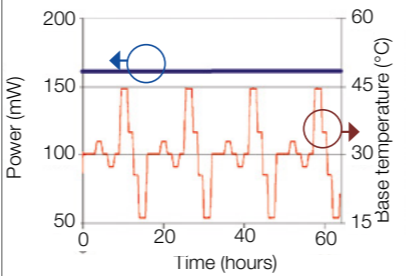

Beam Profile LBX-633S

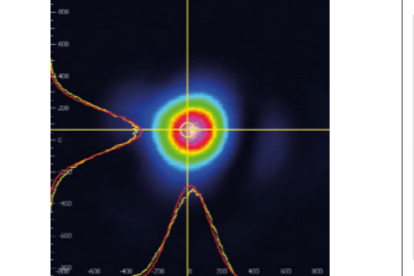

LiNb Raman Spectrum obtained with LSX-785S

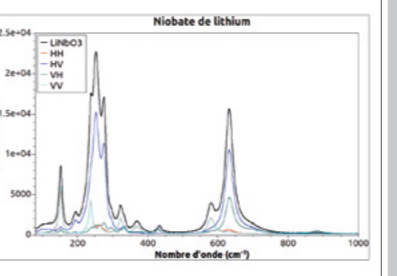

LBX & LSX Platform

Technology
LBX & LSX lines are performing driver integrated platforms for stabilized laser diode.

Benefits
LBX-S and LSX-S deliver ultra narrow linewidth thanks to its excellent temperature stability and low noise current. The Oxxius proprietary embedded firmware locks the laser on same mode at each start up.

Fiber coupling options

Fiber coupling options offer rugged and compact solutions to couple LaserBoxx into polarization maintaining fiber, standard single mode fiber or multimode fiber.

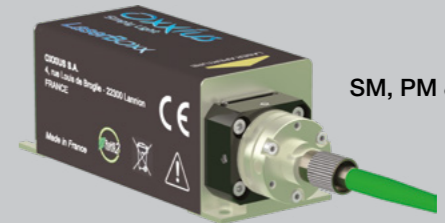

SM, PM & MM Fiber coupling

Specifications		
SM and PM Fiber		MM Fiber (50 μm, 0.22 NA)
≥ 70 % (except LBX-S)	Coupling Efficiency	≥ 80 %
100 :1	Polarization Ratio (PMF only)	n/a
FC-APC FC/PC, FCP8 on demand	Fiber Output Connector	SMA
± 2 %	Power Stability over 8 hours, ± 1.5 °C	± 2 %
2.0 m	Fiber length	2.0 m

Mechanical Drawings

LCX series, Plug & Play DPSS Laser

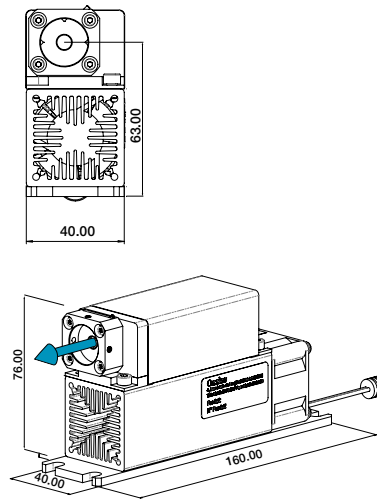

LPX series, Plug & Play DPSS Laser

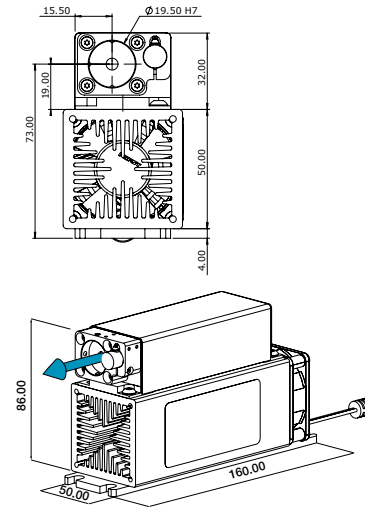

LBX series, Plug & Play Stabilised laser diode

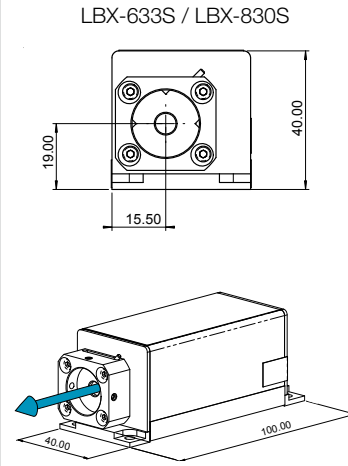

LSX series, Plug & Play Stabilized laser diode Integrated isolator

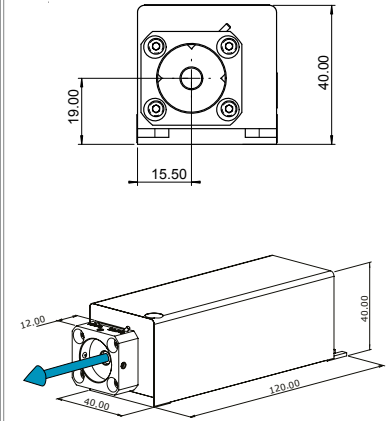

PPA - ControlBoxx

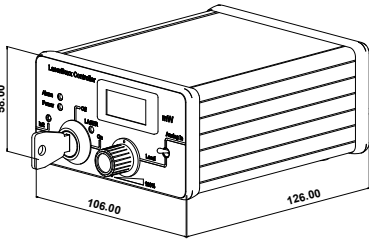

With power adjustable

PPF - RemoteBoxx

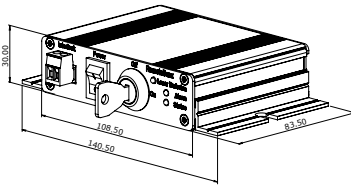

Standard fixed output power

Optional heatsink for LCX and LBX series

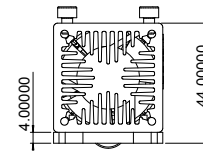

Optional air-forced heat sink for maximum ambient temperature of 38°C.

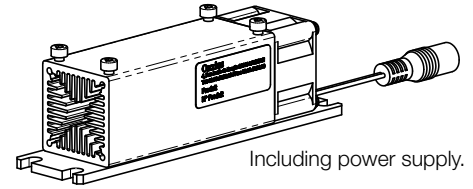

Including power supply.

LCX series, OEM DPSS Laser

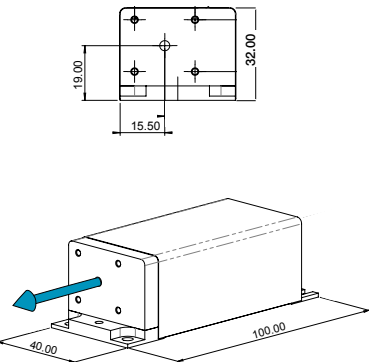

LPX series, OEM DPSS Laser

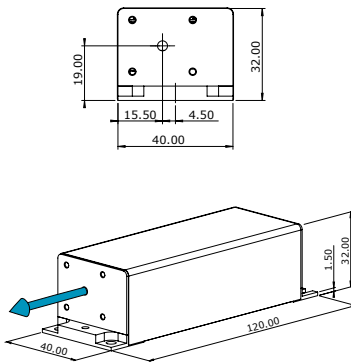

LBX series, OEM Stabilized laser diode

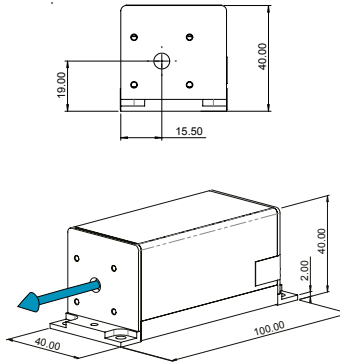

LSX series, OEM Stabilized laser diode Integrated isolator

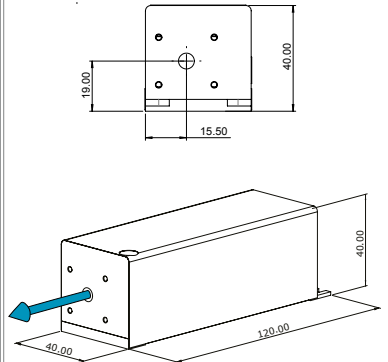

All-In-One laser head with built-in controllers. Input voltage range: 5-12 V DC



Photonic Solutions Ltd Unit 2.2, Quantum Court, Research Avenue South, HWU Research Park, Edinburgh, EH14 4AP, UK, Tel: +44 (0)131 664 8122 Email sales@photonicsolutions.co.uk Web www.photonicsolutions.co.uk



VISIBLE AND INVISIBLE LASER RADIATION
AVOID EXPOSURE TO BEAM
CLASS 3B LASER PRODUCT
Power up to 500 mW

VISIBLE AND INVISIBLE LASER RADIATION
AVOID EYE OR SKIN EXPOSURE TO DIRECT OR SCATTERED RADIATION
CLASS 4 LASER PRODUCT