

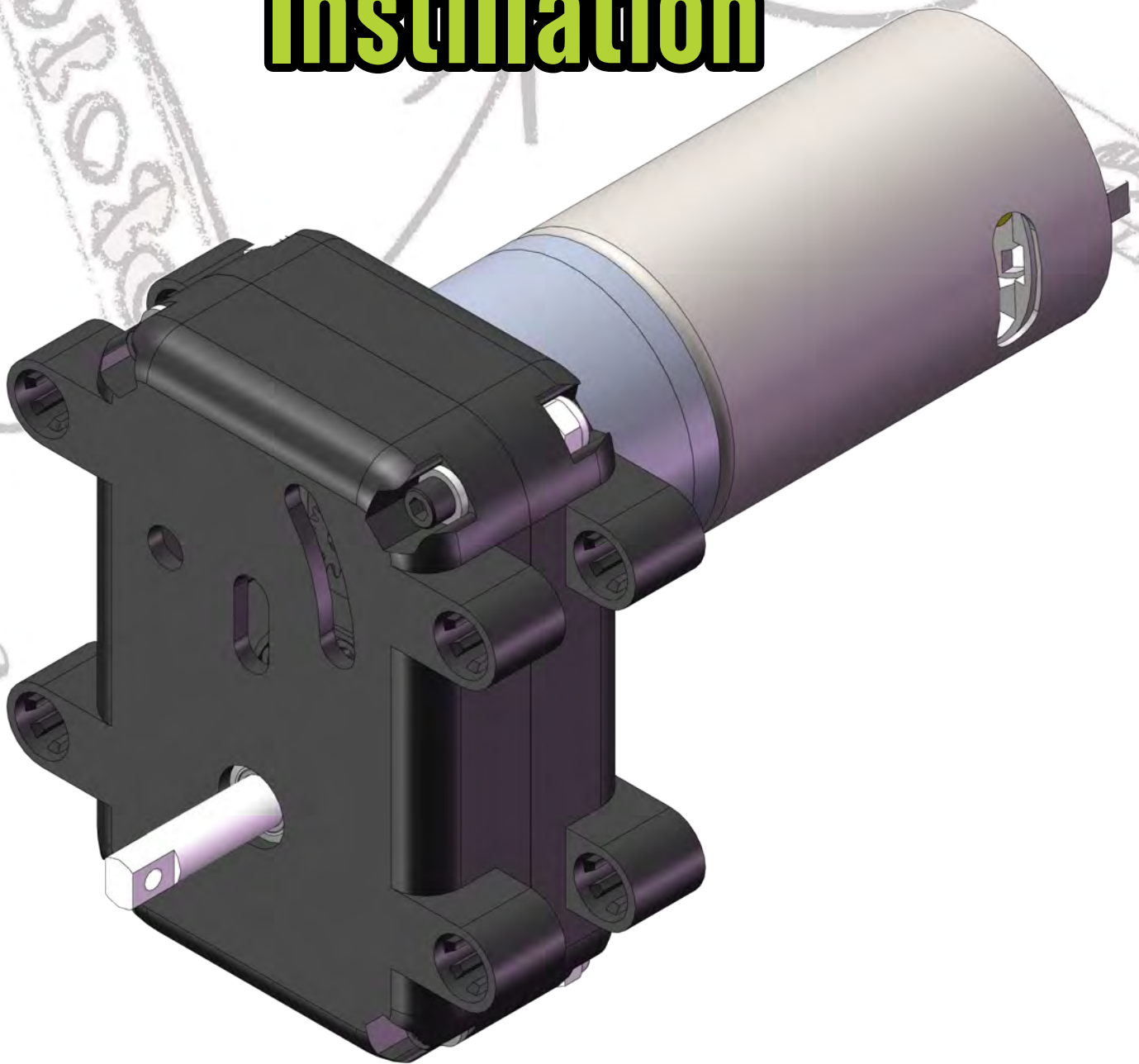

MINDS-i

000-0000-000

6x6 Gear Reducer Instillation



Helpful instructional videos available at: mindsirobotics.com

01

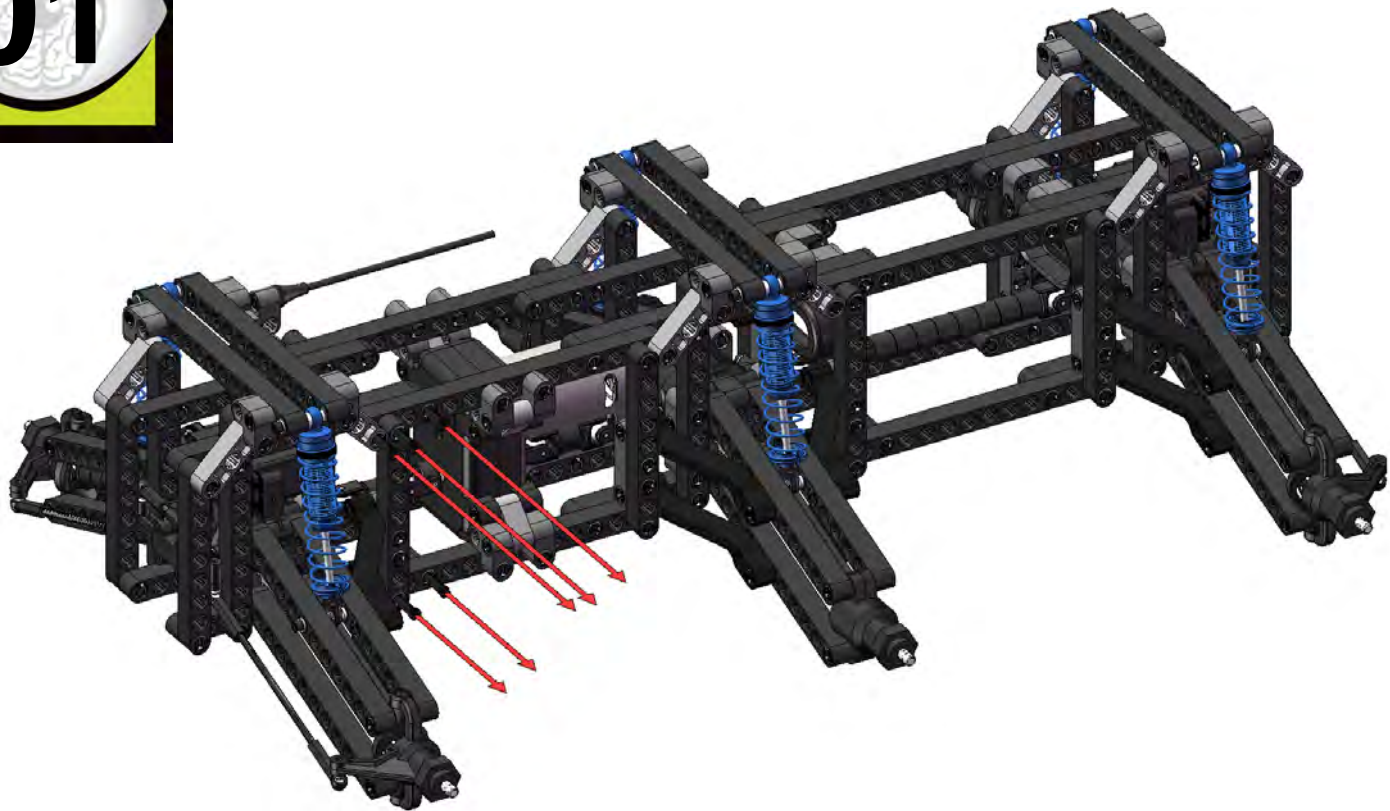

02

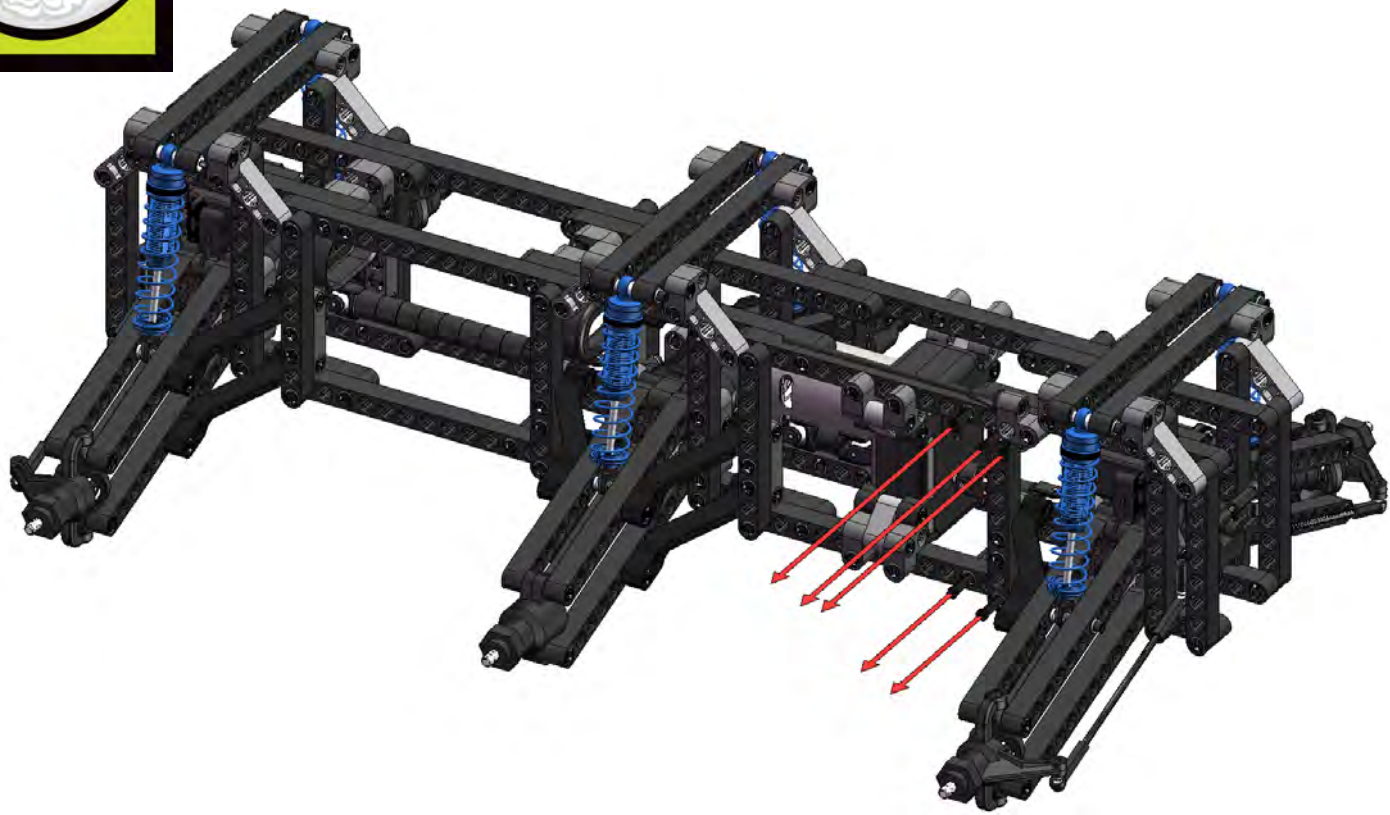

03

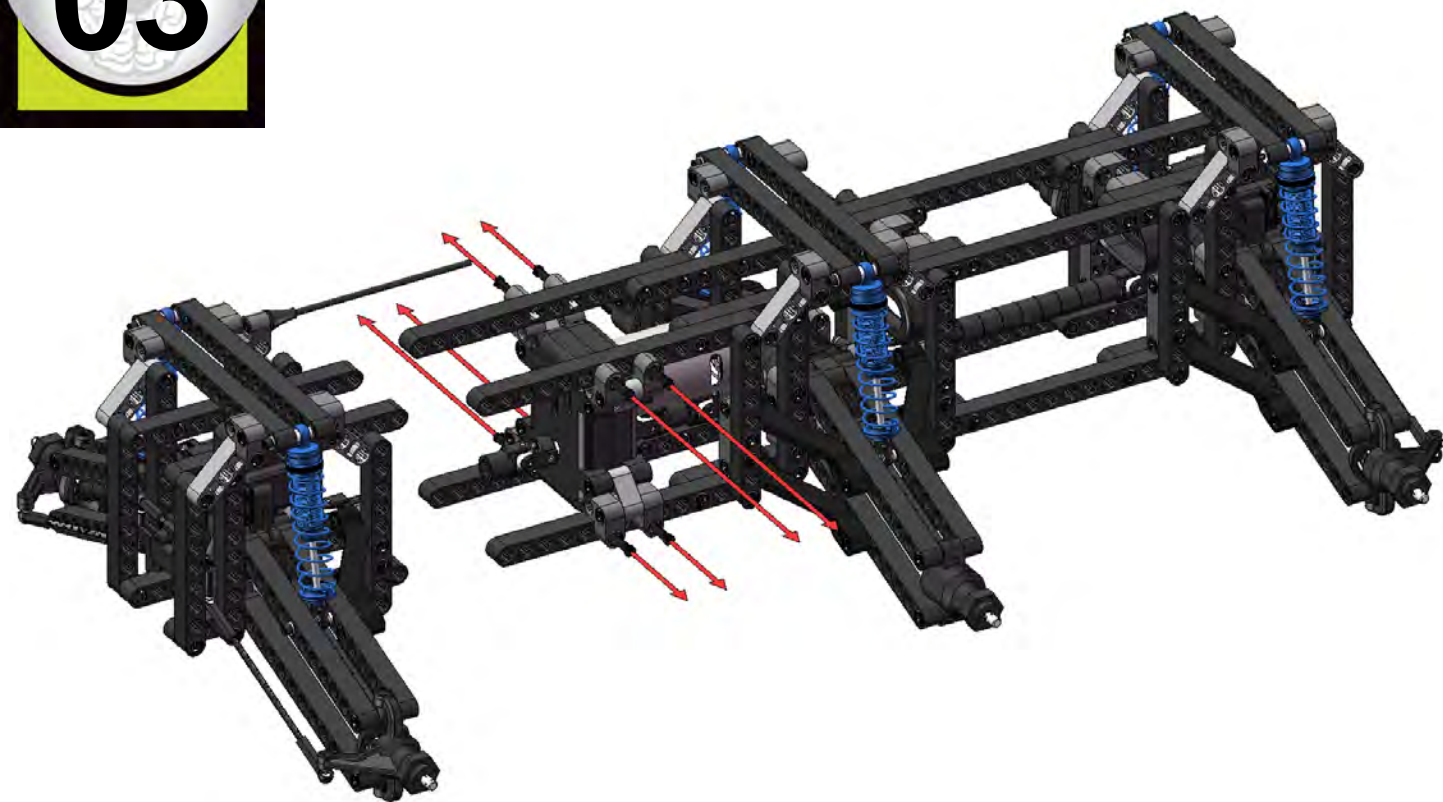

04

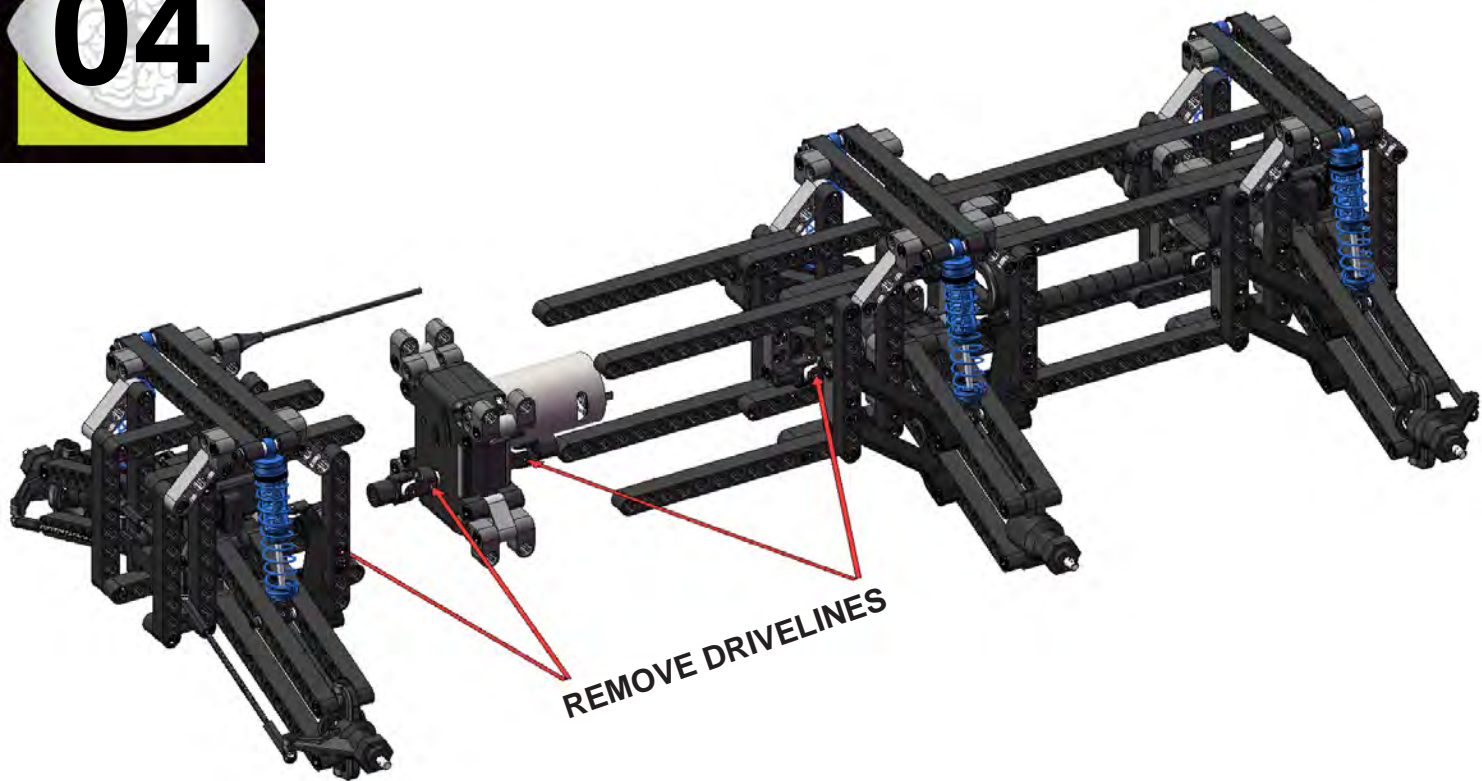

05

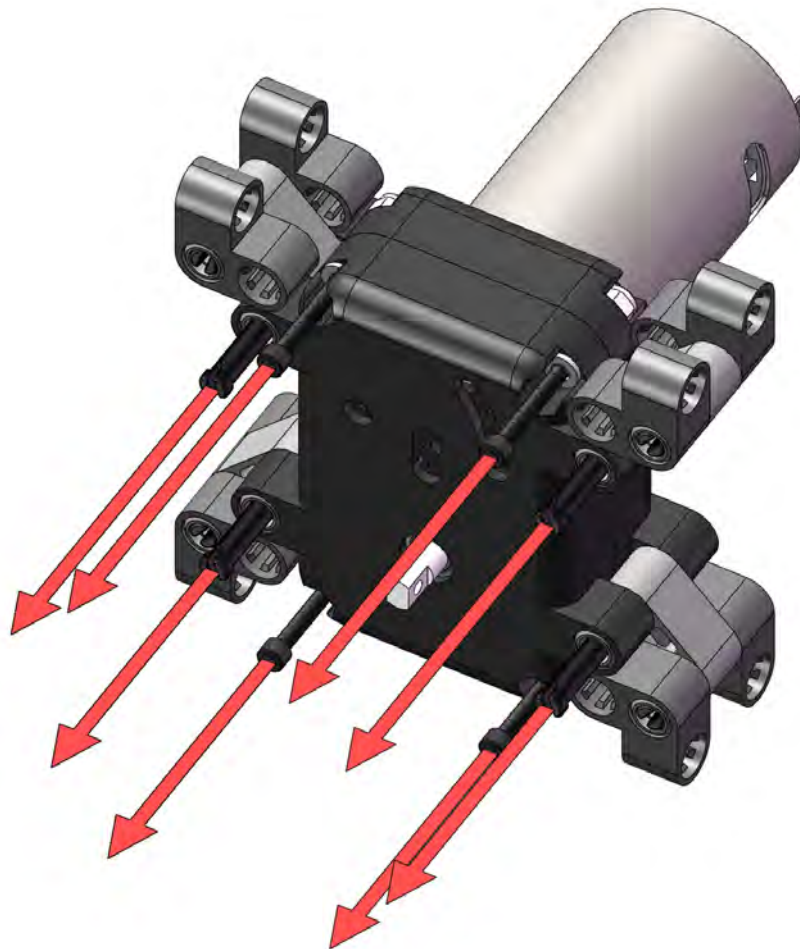

06

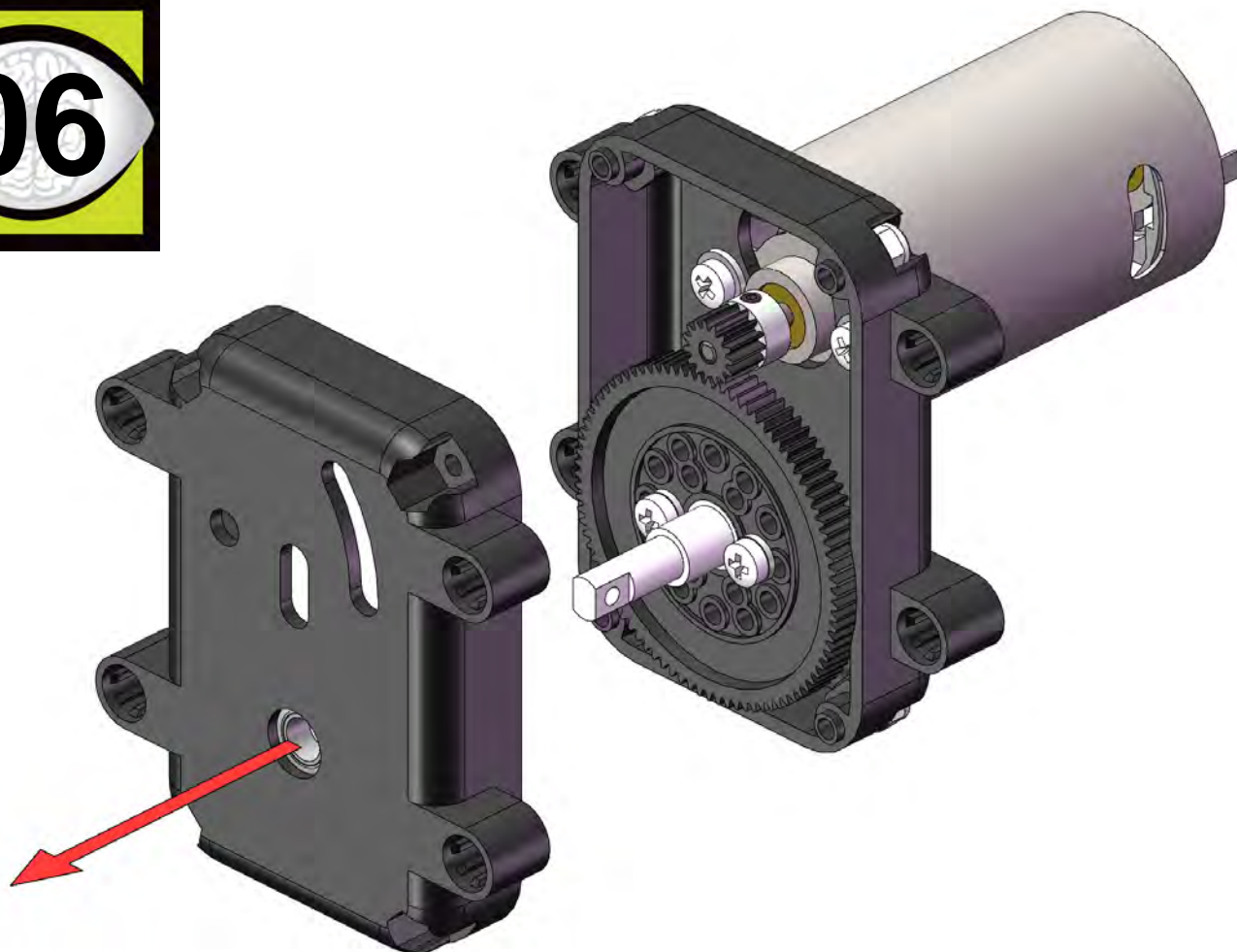

07

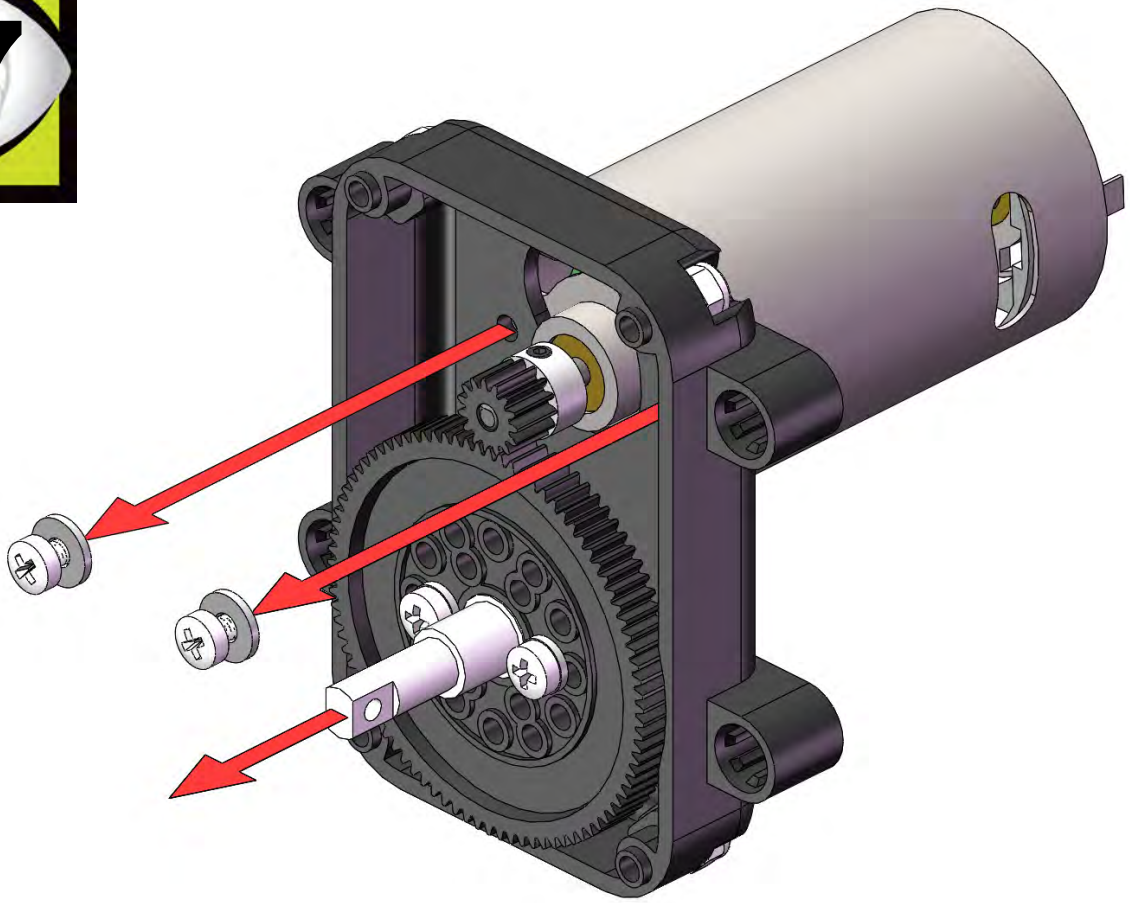

08

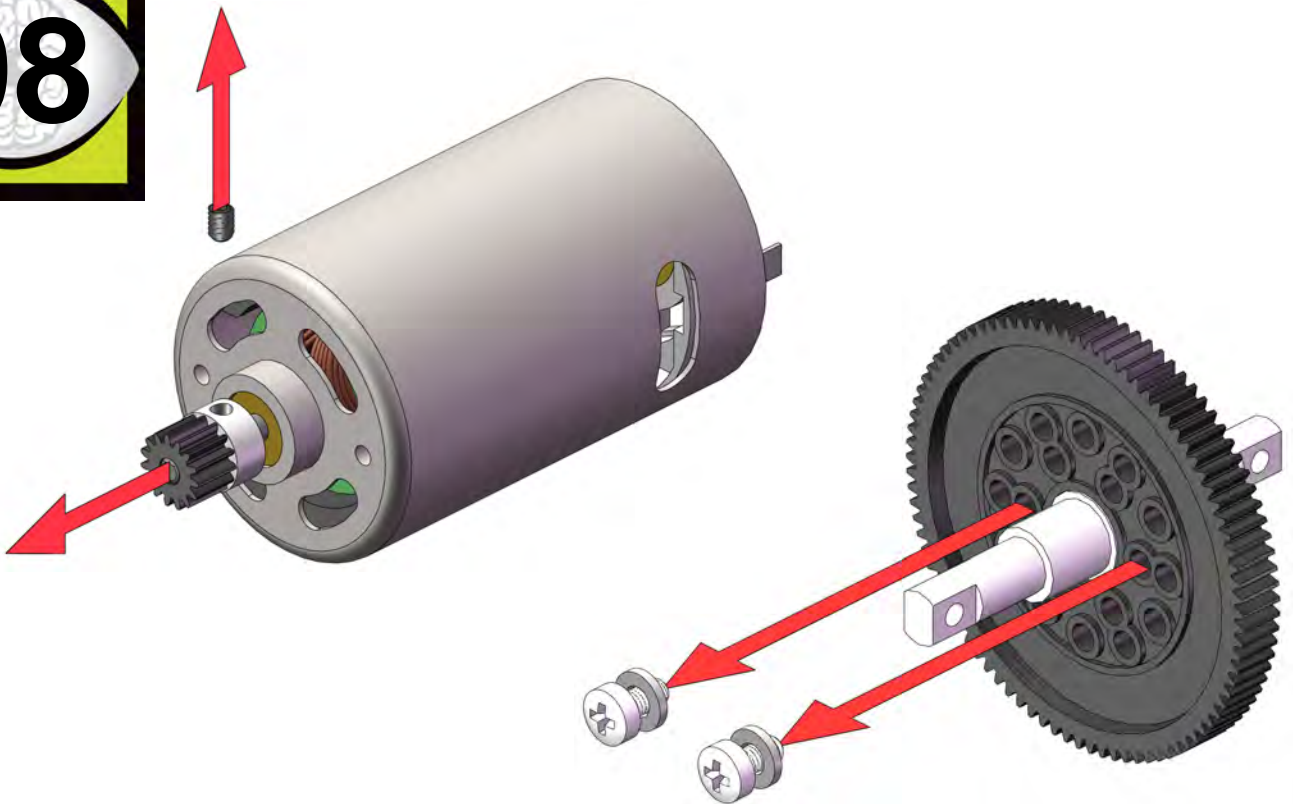

09

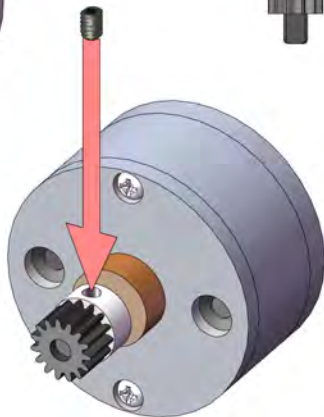
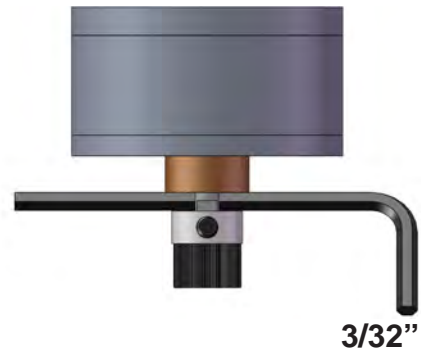
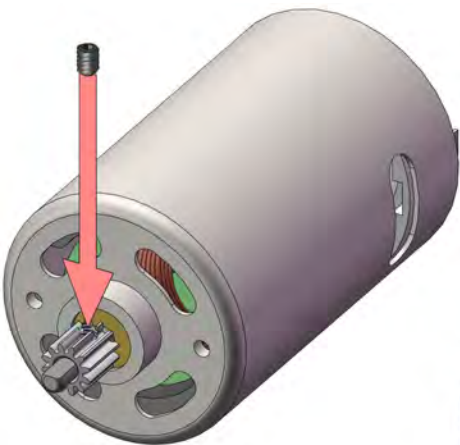

USE THE ALLEN WRENCHES TO SPACE THE PINION GEARS AS SHOWN ABOVE.

10

x2
ENCODER SHAFT



x2
M3x25mm SCREW

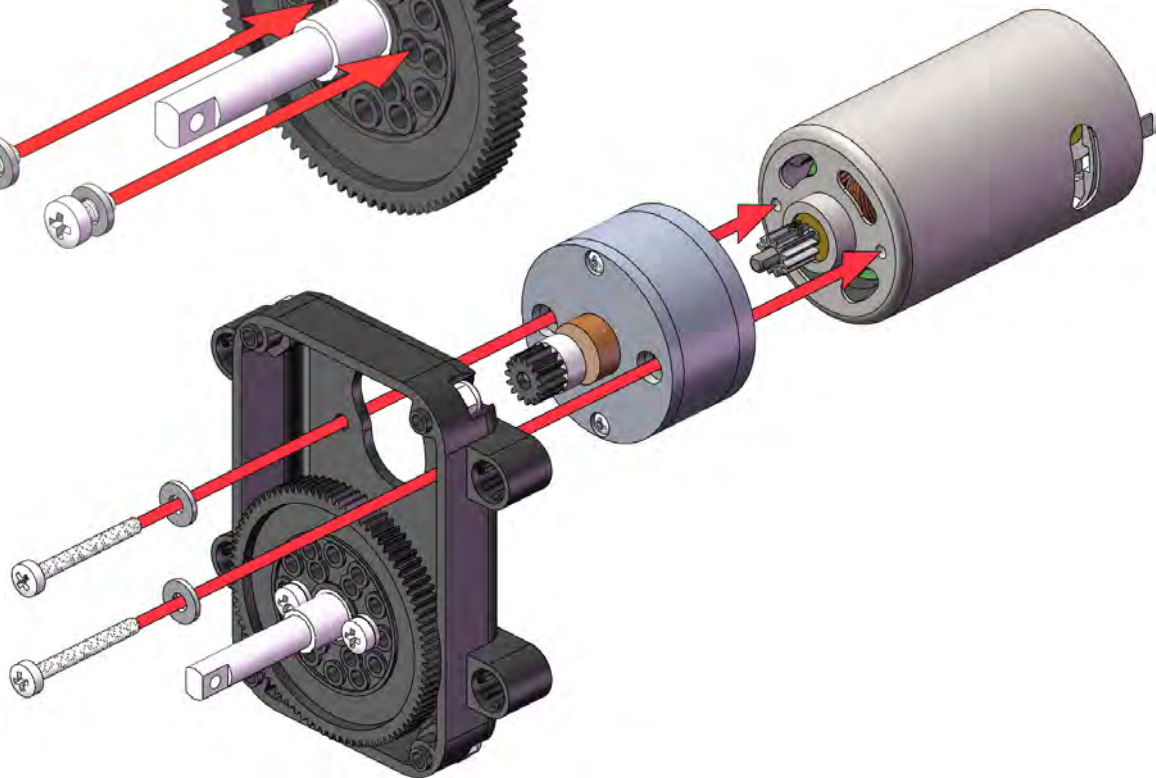
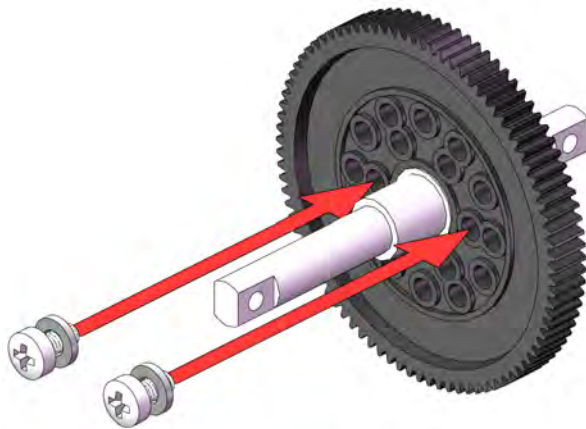



x4
#4-40 x 3/4" SCREW

x4
#4 WASHER

x4
#4-40 NUT

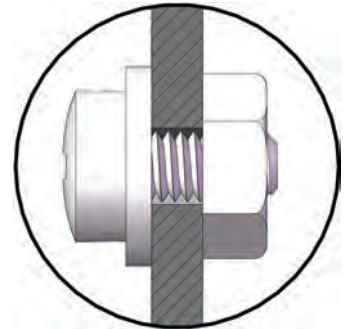
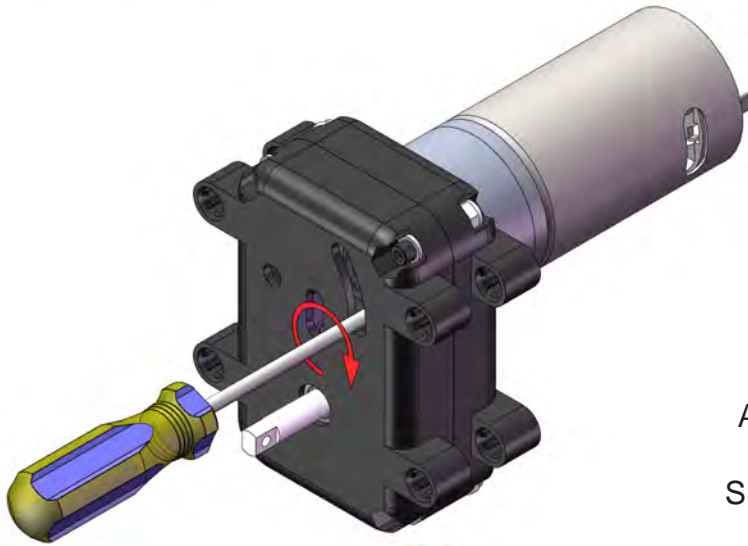
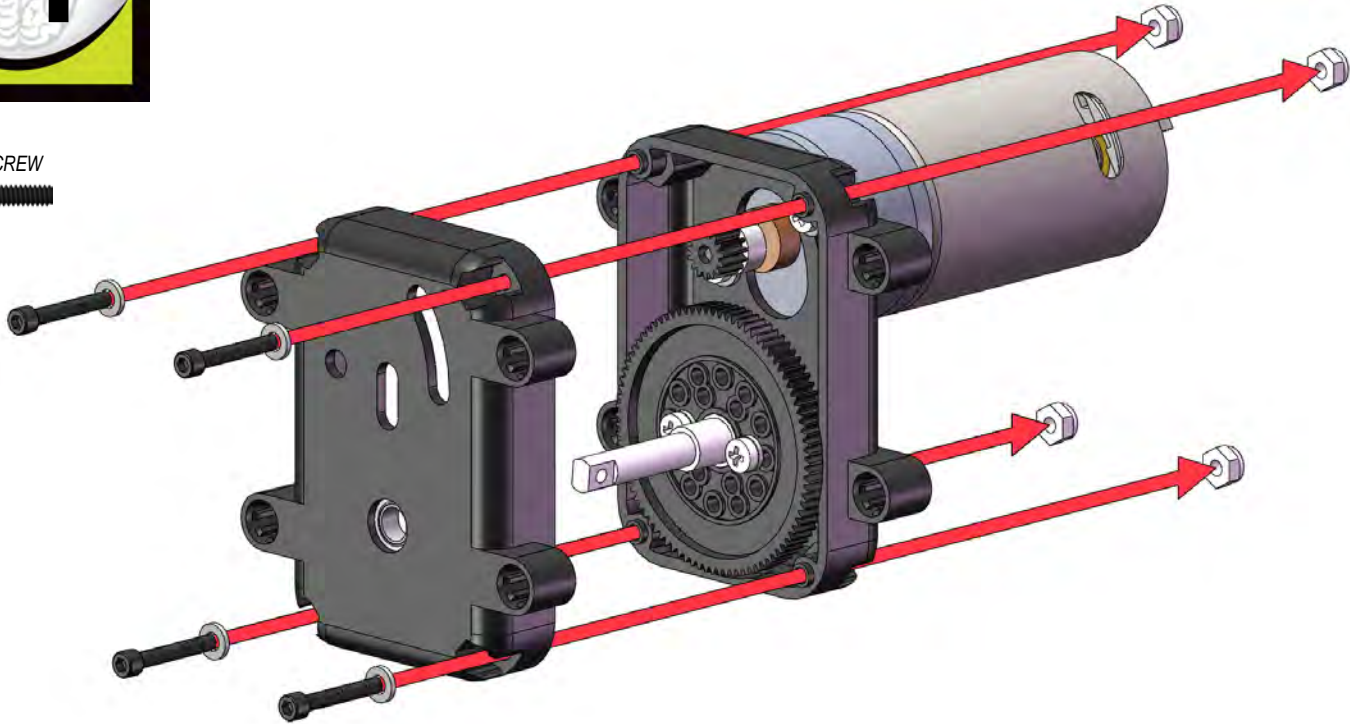

ADJUST MOTOR SCREWS
UNTIL GEARS MESH
SMOOTHLY, THEN TIGHTEN



WHEN ALIGNING THE GEARS TOGETHER MAKE SURE THEY ARE ABOUT A PAPER'S THICKNESS APART SO THEY MESH SMOOTHLY. DO NOT LEAVE THEM LOOSE OR PRESS THEM TOO TIGHT TOGETHER OR IT MAY DAMAGE THE GEARS OR PUT TOO MUCH STRESS ON THE MOTOR.

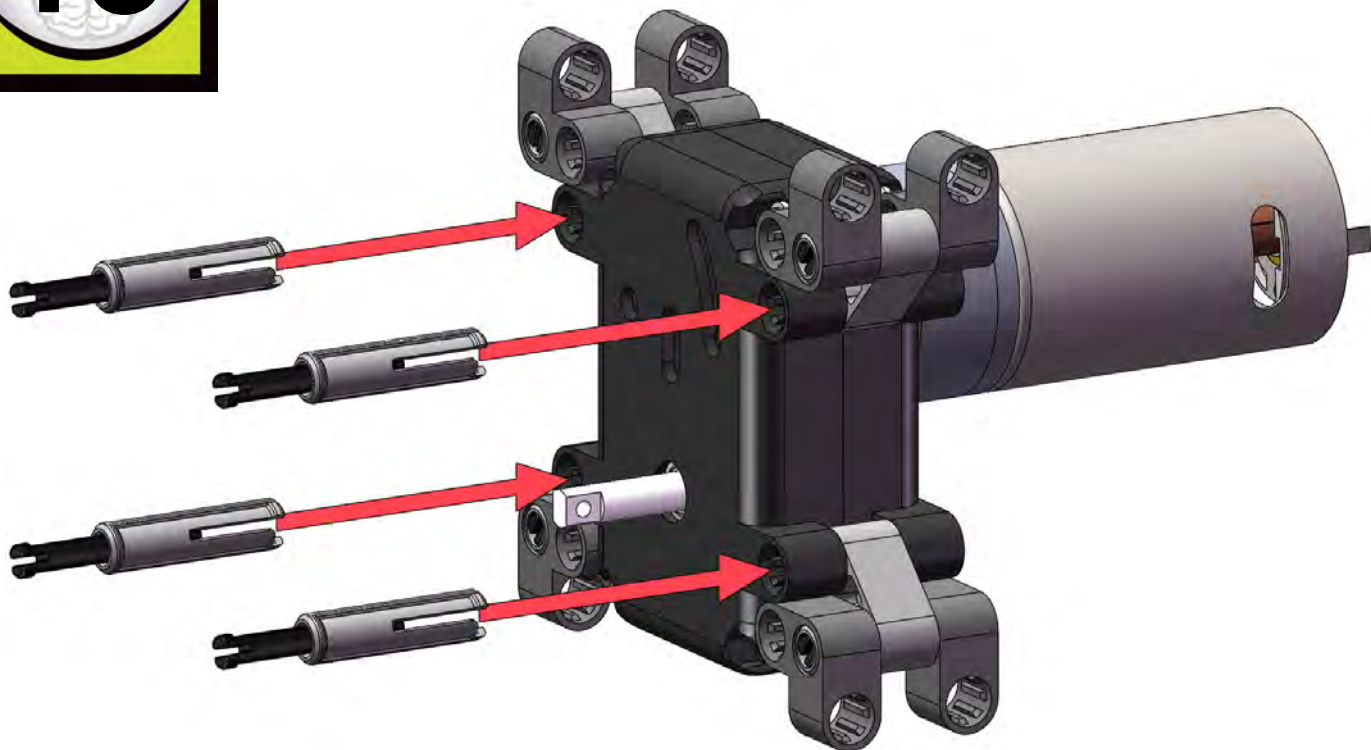

x1
3-DRIVELINE



x1
0-DRIVELINE

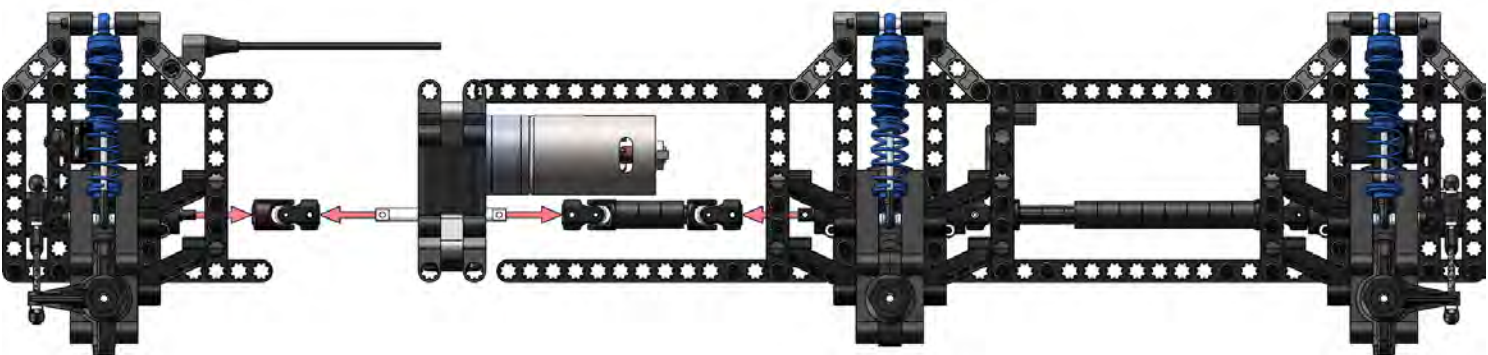

15

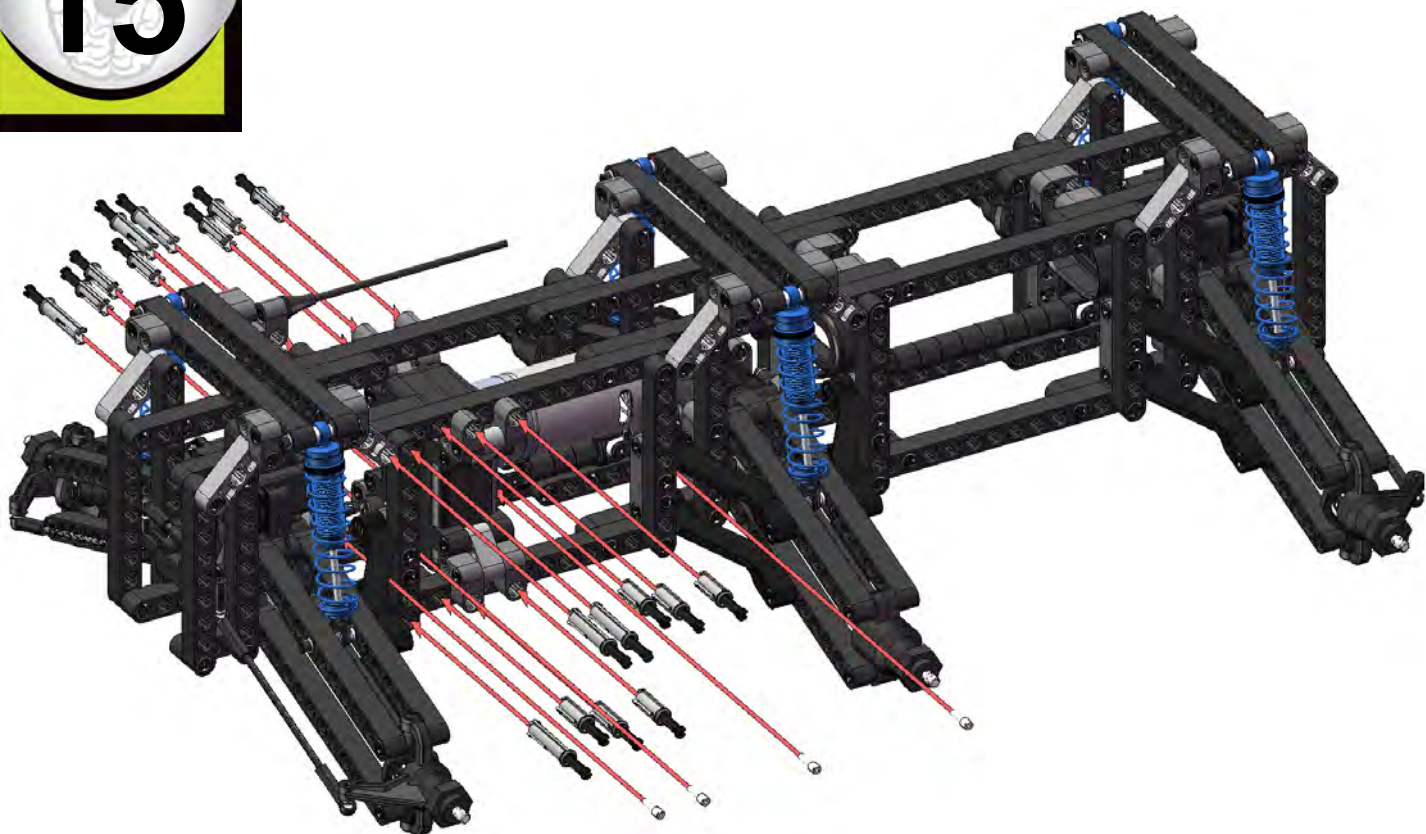

16

