



MINDS-i

CKE-TR04-001

4x4 Robot Kit

3-in-1

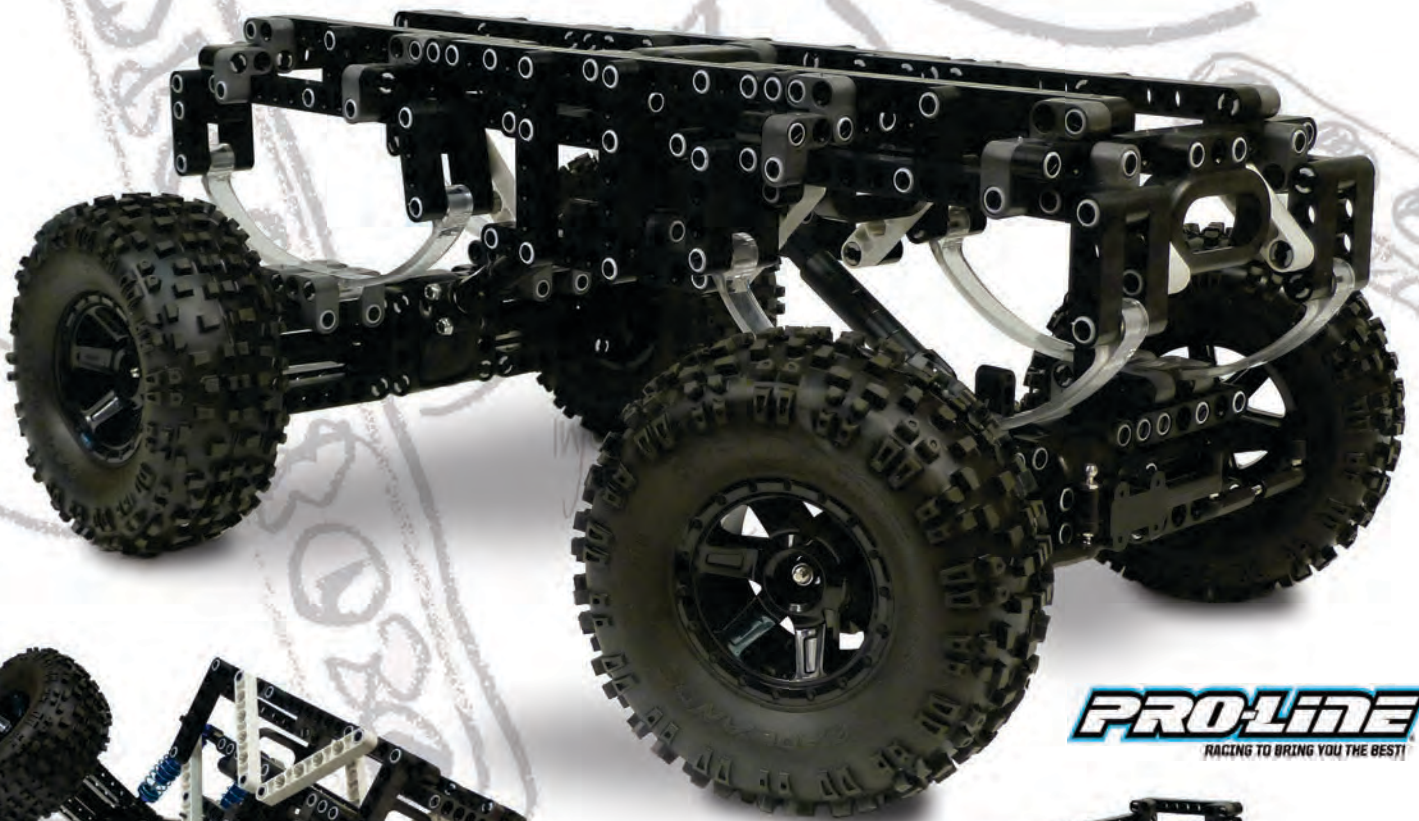

PRO-LINE
RACING TO BRING YOU THE BEST!



Helpful instructional videos available at: mindsieducation.com

MINDS-i® PRODUCT SAFETY INFORMATION

When safety precautions are followed, your MINDS-i® system will provide years of enjoyment. Use care and good sense at all times when operating this product. Failure to use your system in a safe, sensible manner can result in injury or damage to property. You and you alone must insure that the instructions are carefully followed and all safety precautions are obeyed.

- Water can cause the electronics to short out and can cause permanent damage.
- Always turn on the transmitter before turning on the receiver.
- Fully extend the transmitter antenna before operating your vehicle.
- Before turning on your radio system, check to make sure that no one else is running on the same frequency.



CHOKING HAZARD: Do not allow children under age 3 or any individuals who have a tendency to place objects in their mouths to play with any part of the MINDS-i system, including, but not limited to: connectors, pieces, electronics, radio transmitters, wheels, tires. The system contains small parts which could accidentally be swallowed and cause suffocation.

- When the system is powered and/or in motion, keep fingers, face, tools, loose clothing, hair, and all other body parts away from gears, wheels, etc. Do not wear gloves while operating machinery. Even plastic parts can pinch, cut, or crush.
- The transmitter's antenna could also cause injury if played with violently or pointed towards someone's face.
- Never operate your MINDS-i® system on streets or in any areas where full-size vehicles are.
- Do not pick up your MINDS-i® system when it is in motion.
- Never charge, run or store your MINDS-i® system in a location subject to high temperatures, low temperatures or high humidity. Do not store in direct sunlight.
- To avoid electronic malfunction, do not allow the vehicle to become wet. Short circuits will produce a very strong electrical current. Should your MINDS-i® system become wet, stop using it immediately.



WARNING! Electrocutation Hazard. Do not use the materials provided for other than its intended purpose.

- Do not put it into fire.
- Always use recommended batteries. If improper batteries are used, they may become hot, leak and may rupture.
- Do not attempt to recharge non-rechargeable batteries.
- Only batteries of the same equivalent type as recommended are to be used. Do not mix old and new batteries.
- Exhausted batteries are to be removed from the system and replaced with new ones. Recycle all used batteries.
- Do not lick batteries. If battery appears to be leaking or has a crystalline deposit on the outside, dispose of it immediately (wear gloves when handling, preferably nitrile or other non-reactive material).
- Do not run a wire between battery terminals, as wire will get very hot, can be irreparably damaged or explode.
- Make sure the batteries are installed with the correct polarity as shown. Do not disassemble your batteries. Never allow them to become hot or to burn. To avoid short-circuits, avoid getting them wet. Do not short circuit batteries.
- If liquid from inside the batteries contacts your skin or clothes, wash them with water. If leaked battery fluid gets into your eyes, flush them immediately with cool water and seek medical attention. Do not rub eyes.
- Always wear safety glasses to protect your eyes. Note that normal glasses, while usually made of impact-resistant plastic, will not afford sufficient protection from shrapnel or flying debris.
- Always wear close-toed shoes to protect your feet from heavy or sharp objects, which might be dropped.
- If you have long hair, keep it tied back or under a hat to avoid it becoming caught in moving parts.
- The MINDS-i® system contains small parts. Do not ingest. Do not insert into any orifice (e.g. nostrils, ears, etc).
- The system contains metal parts. Cutting or bending can cause parts to break; resulting in sharp edges which can cut skin.
- Battery disposal. Do not throw batteries into the trash, especially rechargeable batteries. Contact your local waste disposal office for information on battery disposal. Batteries should be stored as directed by your local hazardous materials disposal office until pickup (usually in a hard sided waterproof, non-conductive container, e.g. a plastic bucket).



WARNING! IMPORTANT! RESPONSIBLE ADULT SUPERVISION IS REQUIRED FOR CHILDREN UNDER THE AGE OF 14. THIS PRODUCT IS NOT DESIGNED FOR UNSUPERVISED USE BY CHILDREN YOUNGER THAN 14 YEARS OLD.

All pictures descriptions and specifications found in this instruction manual are subject to change without notice.

MINDS-i® maintains no responsibility for inadvertent errors in this manual. Visit www.mymindsi.com for the latest updates and information.

MINDS-i® is a high-performance Construction/RC/Robotics System, which is NOT intended for use on the public roads or congested areas where its operation may conflict with or disrupt pedestrian or vehicular traffic. Read all enclosed information before operating. Fully illustrated, step-by-step instructions describe adjustment, operation, and required maintenance procedures. MINDS-i® should not be operated in a crowd, or without adequate space. In an effort to continually upgrade our products, MINDS-i® reserves the right to make improvements and modifications to this system, which may not be reflected in the photographs and specifications printed on this box. **PROPOSITION 65 WARNING:** This product contains chemicals known to the State of California to cause cancer and/or birth defects or other reproductive harm.

Terms & Conditions: All orders placed with MINDS-i, Inc (phone, fax, mail, internet/web & email) constitute the acknowledgment and acceptance of all conditions listed below. All purchases remain the property of MINDS-i®, Inc until paid for in full. All orders shipped to a Washington State address must pay sales tax as required by the Washington State Department of Revenue. In the event that an order placed on our web-site does not calculate sales tax and the order is being shipped to a Washington State address, MINDS-i® will calculate the sales tax when the order is processed and call or email the customer with the new amount. All prices, materials, design, color, contents included with a product and product specifications are subject to change without notice. Some product images may be shown with optional items that are sold separately. Depending on the products ordered and the destination of the order, certain shipping services may not be available. MINDS-i® will not be responsible for pricing errors and may cancel the order. Orders will not be shipped until all Credit Card information is verified and matched. All other orders (check or money order) will not be shipped until payment has been received in full. All unpaid orders will be canceled after 30 calendar days. All weights shown for products are used for shipping calculation only and may not reflect actual weight of the product.

Product Warranty: MINDS-i® warrants to the original buyer that our products are free from defects in materials and workmanship for a period of 120 days from the original date of purchase (original purchase receipt required). This warranty does not cover abuse, misuse, incorrect wiring, modifications, alterations, connector damage, wear and tear or robot competition damage. If the Product is determined to be defective within the warranty period, MINDS-i® or its authorized service provider will, at our sole option, repair or replace any defective parts free of charge, or refund the purchase price. What you must do: Return the Product in its original packaging or packaging affording equal protection, freight prepaid, with proof of purchase, to an authorized MINDS-i® service provider. You are responsible for all shipping charges. For more information, contact MINDS-i® at (509) 252-5767 or info@mymindsi.com.

Shipping Errors and Defective Products: Claims for shipping shortages, errors, or defective materials must be in writing and received by MINDS-i® within ten (10) days after receipt of shipment by buyer. Failure to make such claim within the stated period shall constitute an irrevocable acceptance of the goods and an admission that the goods fully comply with all the terms and conditions of the buyer's order.

MINDS-i® is Designed and Manufactured in the United States
Some components are manufactured in China and the Philippines.

Patents US 7,517,270; US 7,410,225; US 7,736,211; US 7,841,923; MX 288350; CN ZL 200680044576.1; Additional Patents Pending.
Trademarks 3,420,137 and 3,487,694
Copyright © 2014 MINDS-i Inc. All rights reserved.

MINDS-i, Inc
22819 East Appleway Avenue
Liberty Lake, WA 99019
USA



PARTS INVENTORY PAGE 1

1:3 SCALE

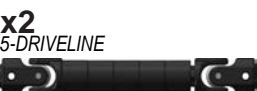
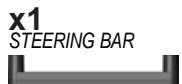
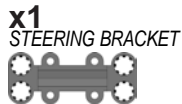
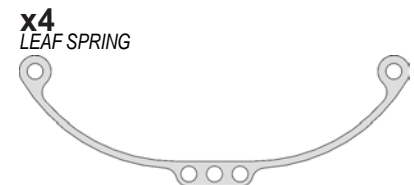
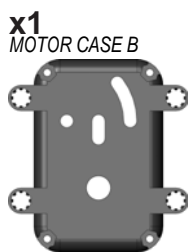
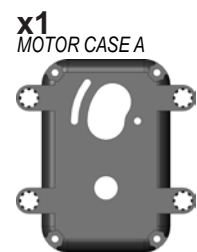

PARTS INVENTORY PAGE 2

1:3 SCALE

x0
4.8" FOUR LINK ARM

x4
3.6" FOUR LINK ARM

x4
2.4" FOUR LINK ARM

x2
2.0" THREAD COLLAR

x6
1.2" THREAD COLLAR

x2
0.4" THREAD COLLAR

x1
7.2v 3000 mAh BATTERY



x1
MOTOR WIRE - BLACK

x1
MOTOR WIRE - RED

x0
23,500 RPM MOTOR



x1
5,000 RPM MOTOR

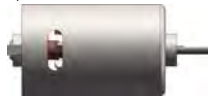

x1
3/32" ALLEN WRENCH



x1
1/16" ALLEN WRENCH



x1
1/4" FLAT WRENCH



x1
CROSS WRENCH



x1
#1 PHILLIPS SCREWDRIVER



x1
MINDS-i TOOL



x2
DIFFERENTIAL CARRIER



x2
OUTPUT GEAR SHAFT



x4
SPIDER GEAR



x2
CARRIER SHAFT



x8
CARRIER SCREW



x1
BATTERY CHARGER



x1
SPEED CONTROLLER



x0
DUAL MOTOR BATTERY CABLE



x1
0.050" ALLEN WRENCH



x2
DIFFERENTIAL SPOOL

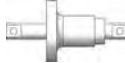

x1
MOTOR SHAFT



x0
M5 WHEEL END SHAFT



x4
M4 WHEEL END SHAFT



x0
COTTER PIN



x0
78-T SPUR



x1
87-T SPUR



x1
15-T PINION



x0
23-T PINION



x4
90mm SHOCK



x0
HS-755MG SERVO

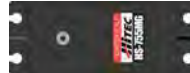

x0
HS-311 SERVO



x0
HSR-1425CR SERVO



x1
HS-485HB SERVO



x0
HS-645MG SERVO

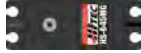

x0
TURNABLE PLATE

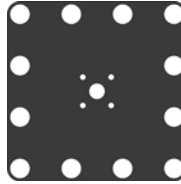

x0
LARGE SERVO PLATE

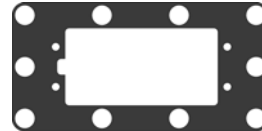

x0
SERVO PLATE



x0
BADLANDS 3.8" TIRE & DESPERADO WHEEL
PROLINE



x0
SERVO Y-HARNESS w/REVERSER



x0
SERVO Y-HARNESS



x0
3" SERVO WHEEL

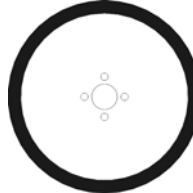

x0
RACECAR WHEEL



x4
BADLANDS 2.2" TIRE & DESPERADO WHEEL
PROLINE



PARTS INVENTORY PAGE 3

1:1 SCALE

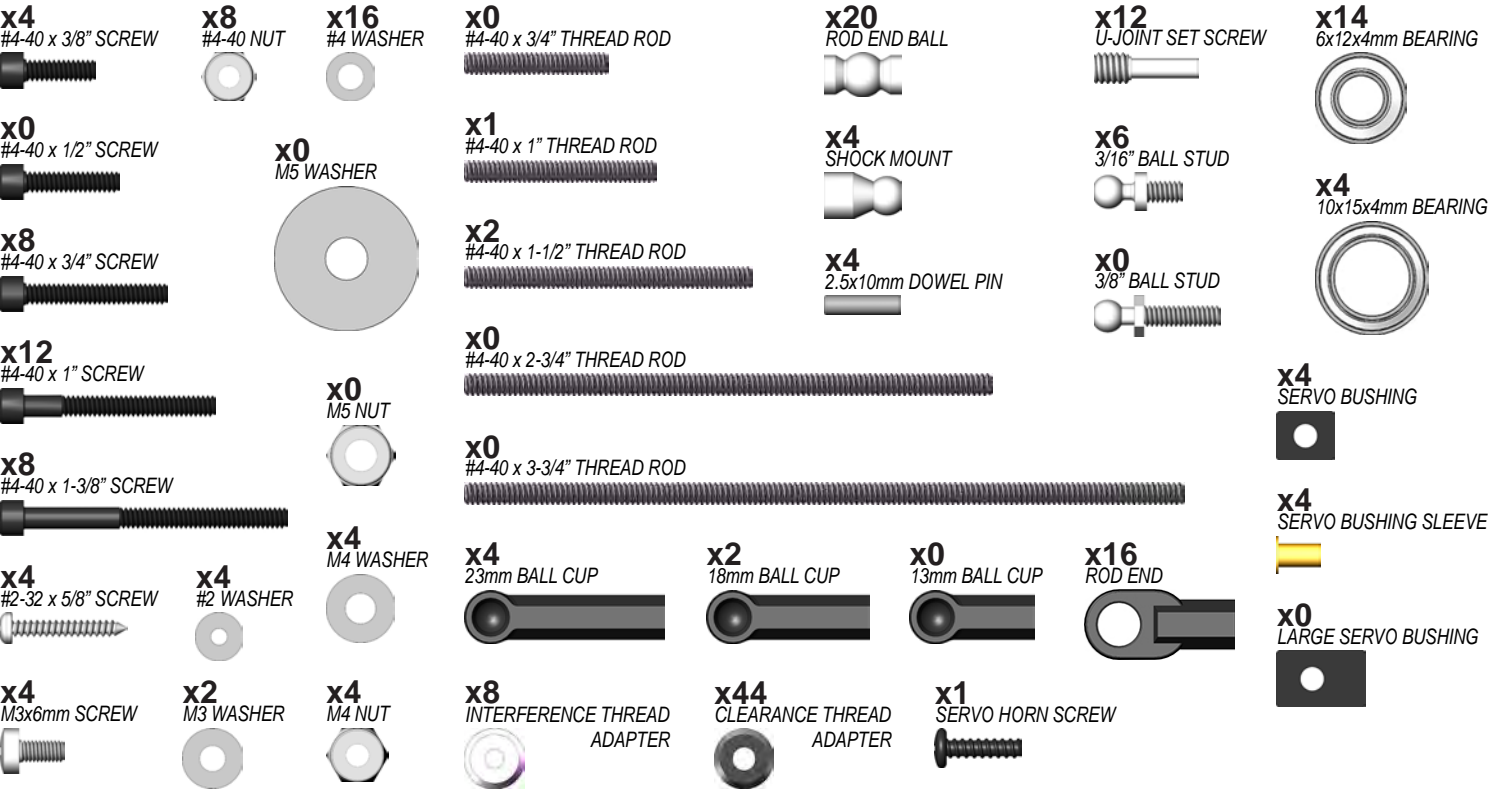

PARTS INVENTORY PAGE 4

1:3 SCALE

x0
ARDUINO BASE PLATE

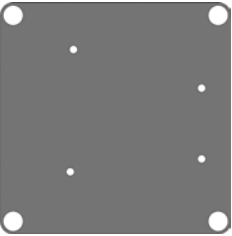

x0
ARDUINO UNO

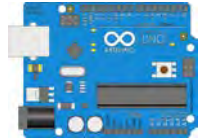

x0
IR DISTANCE SENSOR



x0
PING))) SENSOR



x0
SENSOR SHIELD

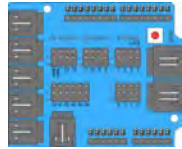

x0
3-PIN CABLE FLAT TO LATCH



x0
PUSH BUTTON



x0
3-PIN CABLE FLAT TO SEPARATE



x0
QTI SENSOR



x0
ARDUINO COVER

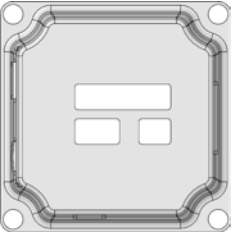

x0
USB CABLE



x0
ARDUINO BATTERY HARNESS



x0
SERVO CABLE MALE TO MALE

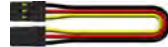

x0
SERVO CABLE MALE TO FEMALE



x0
5x5 IR PANEL



x0
USB THUMB DRIVE



x0
VOLTAGE REGULATOR



CONNECTOR ASSEMBLY AND USAGE

HELPFUL INSTRUCTIONAL VIDEOS AVAILABLE AT: www.mymindsi.com



1.5-LOCK



2-LOCK



3-LOCK



PANEL LOCK



2-ROTATE



3-ROTATE

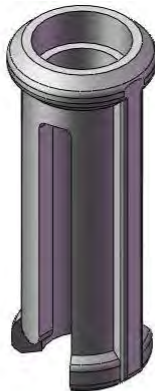

02

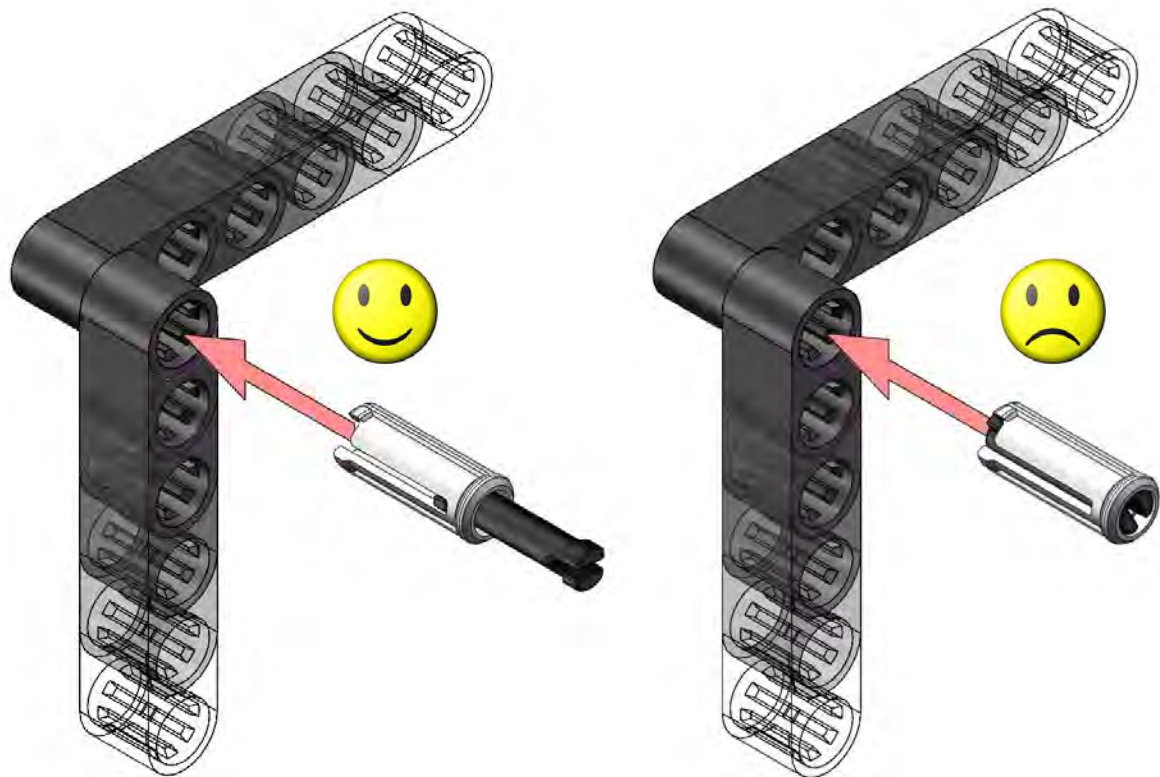

03

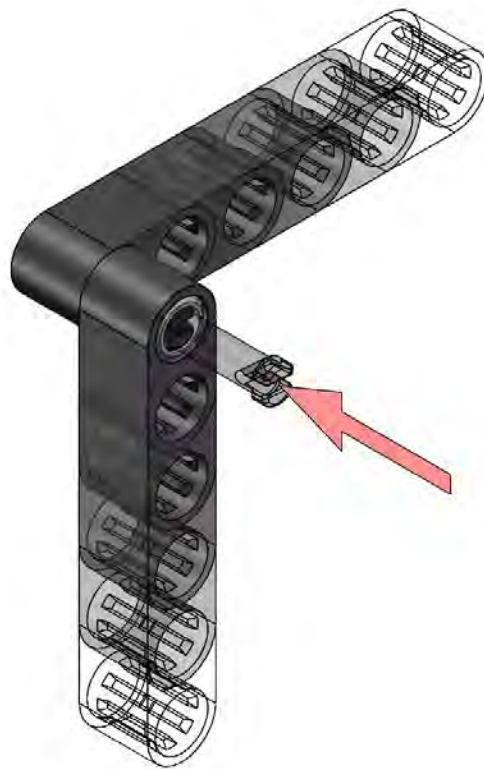

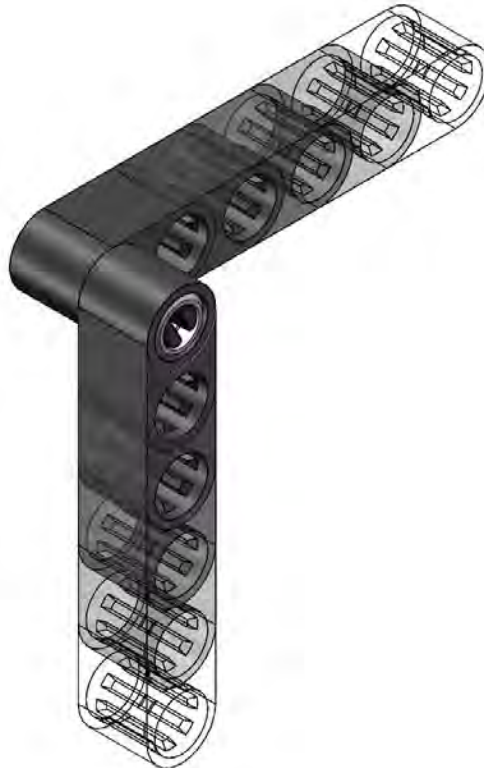
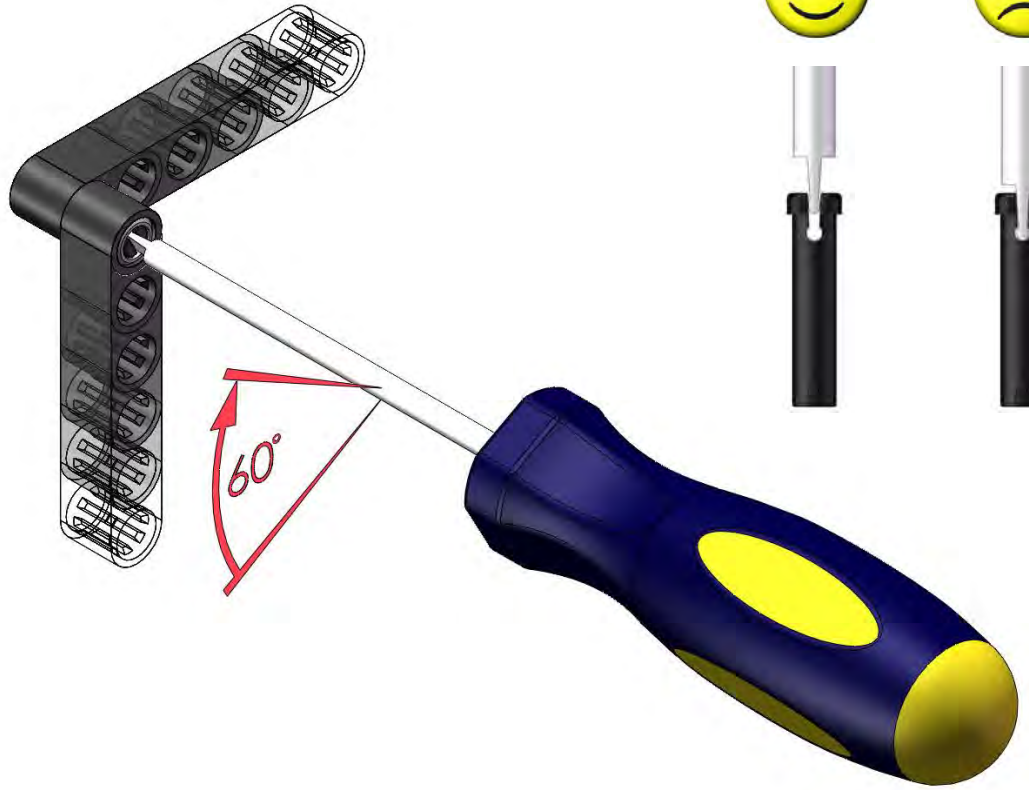

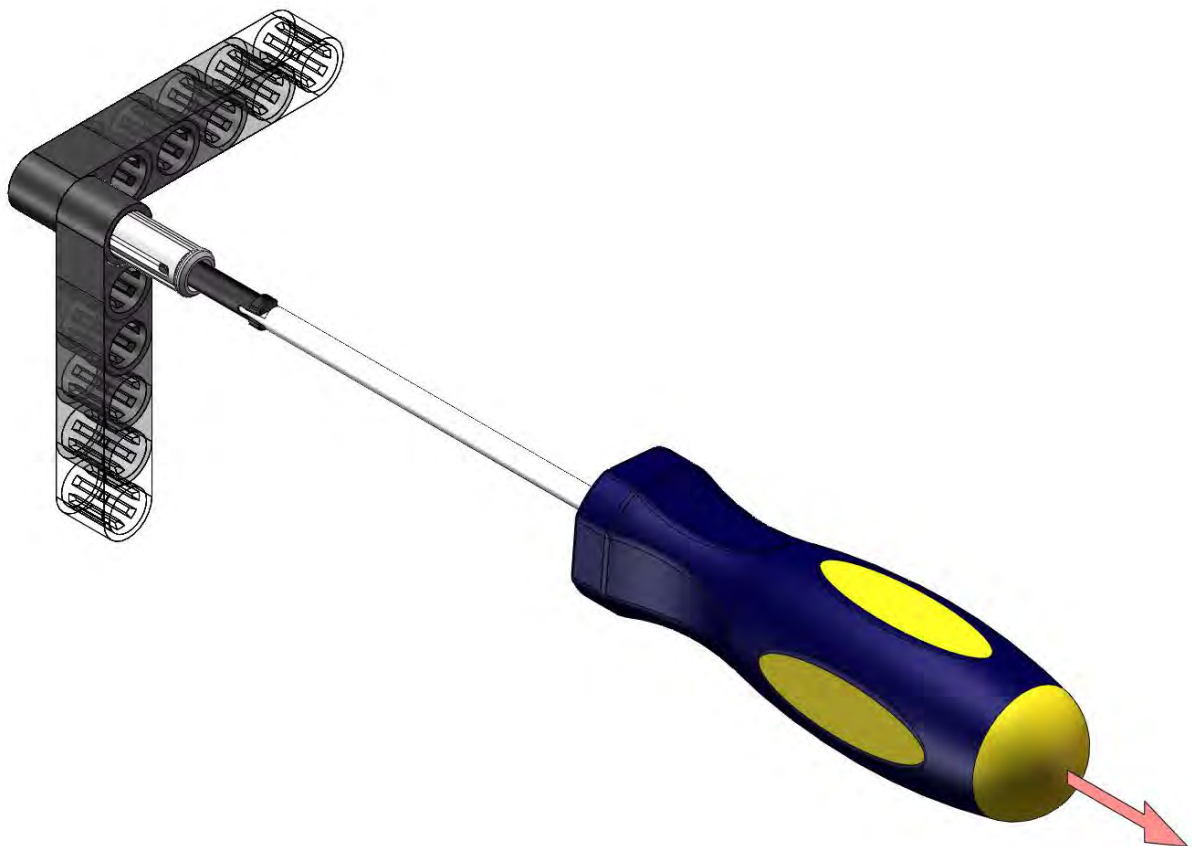
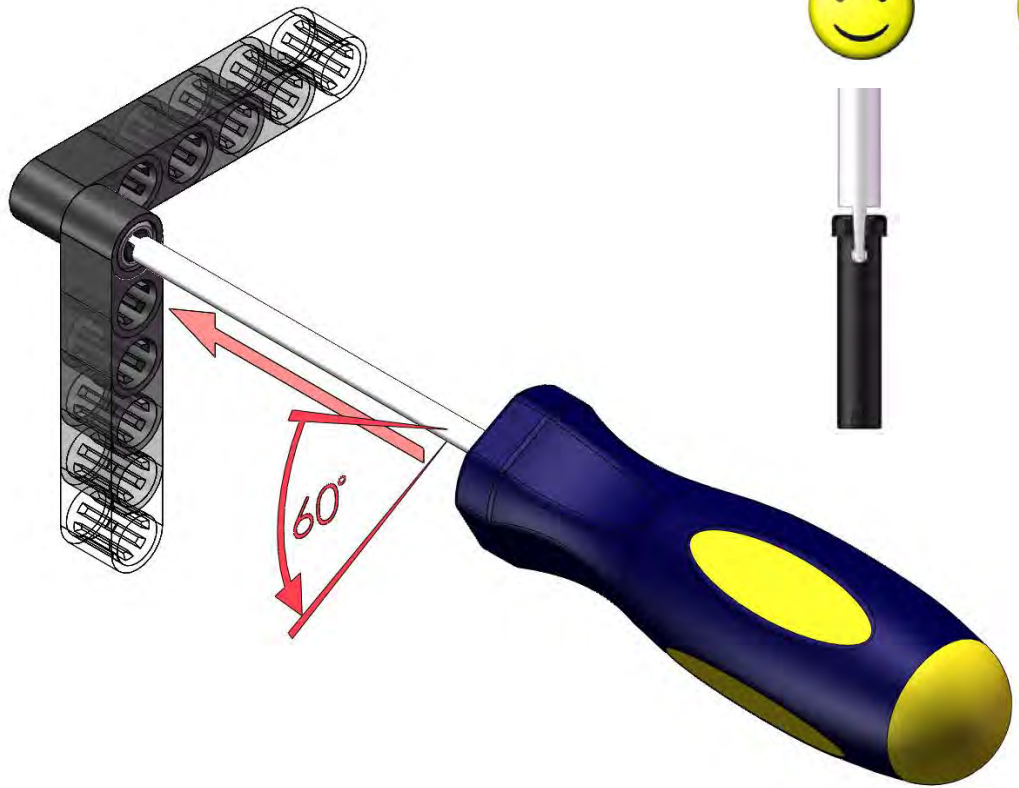

MOTOR CASE ASSEMBLY

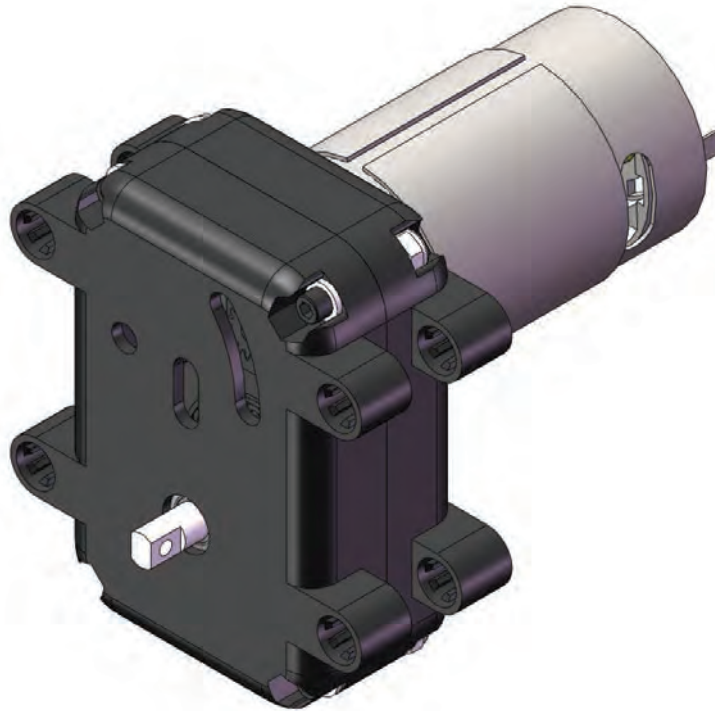

x1
MOTOR CASE A

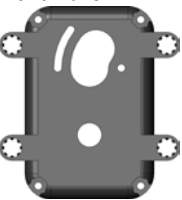

x1
MOTOR CASE B

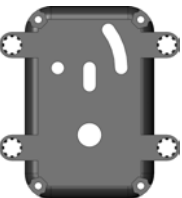

x2
6x12x4mm BEARING

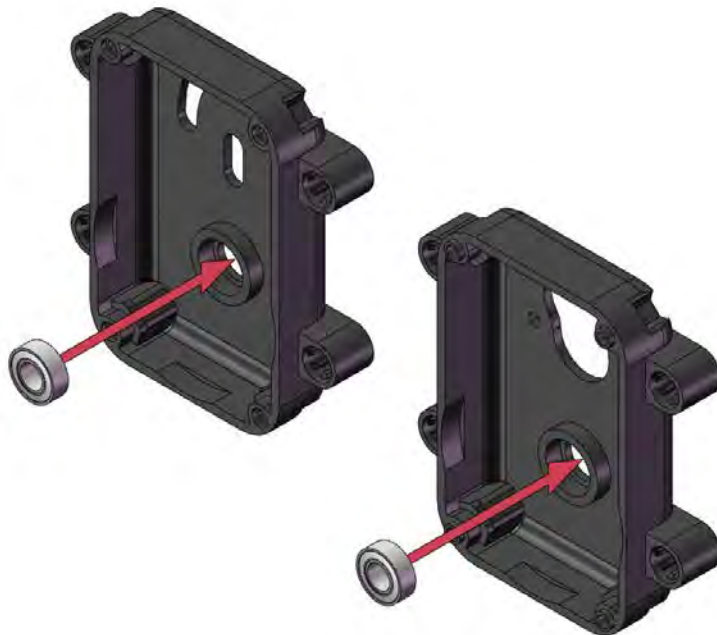

02

x1
MOTOR SHAFT



x1
87-T SPUR



x2
M3x6mm SCREW



x2
#4 WASHER

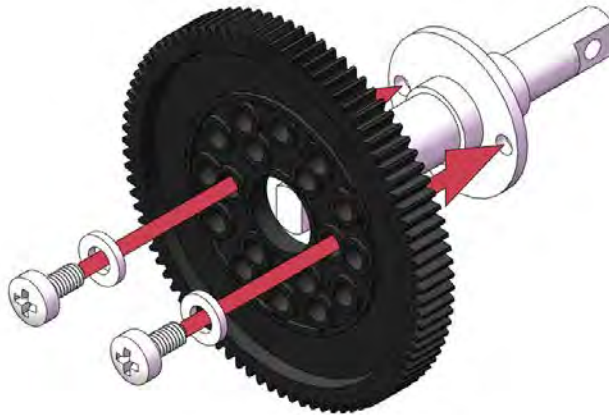

03

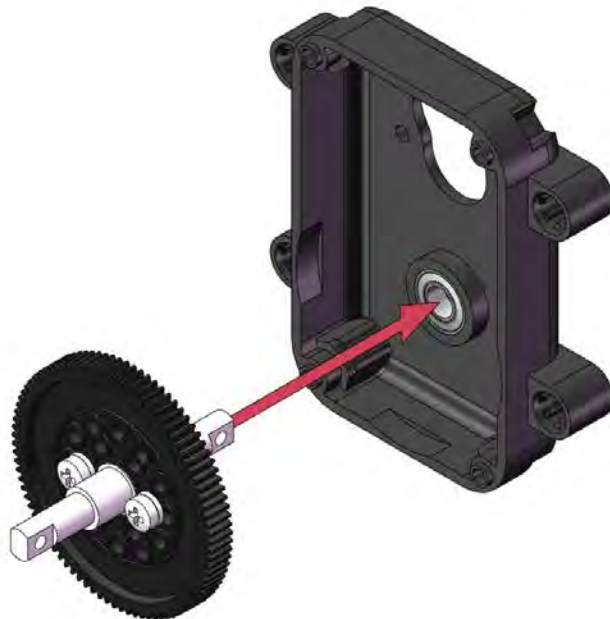

04

BE SURE TO ALIGN THE SET SCREW WITH THE FLAT SPOT ON THE MOTOR SHAFT THEN TIGHTEN PINION SET SCREW.

x1
5,000 RPM MOTOR



x1
15-T PINION

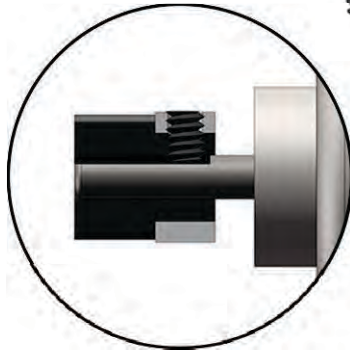
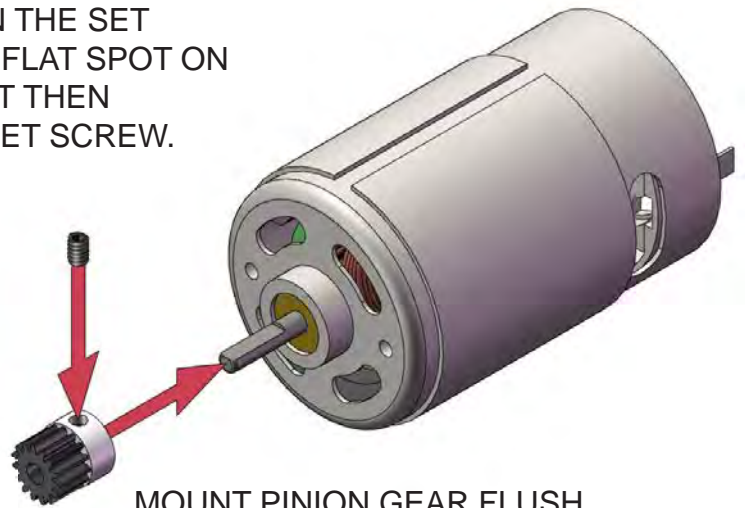

MOUNT PINION GEAR FLUSH WITH END OF MOTOR SHAFT

05

x2
M3x6mm SCREW



x2
M3 WASHER

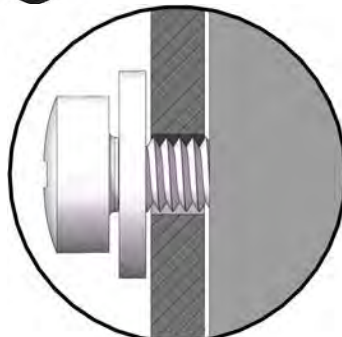
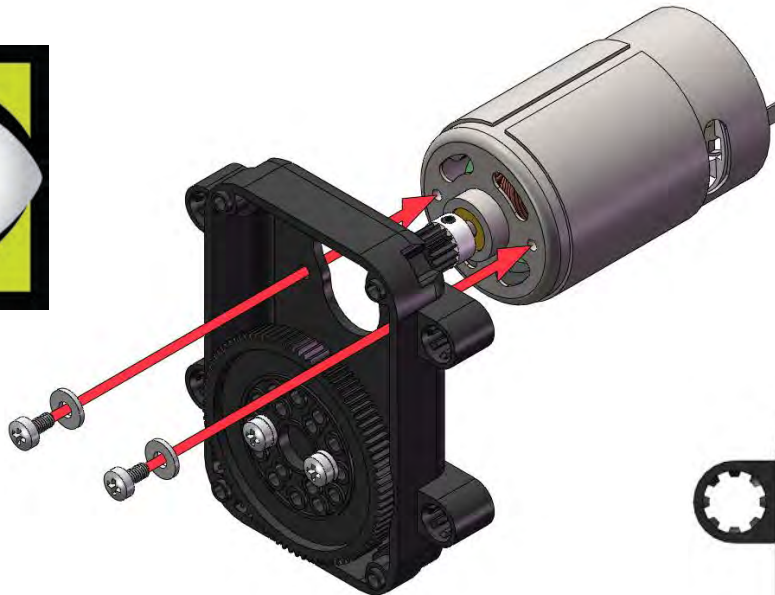

DO NOT TIGHTEN

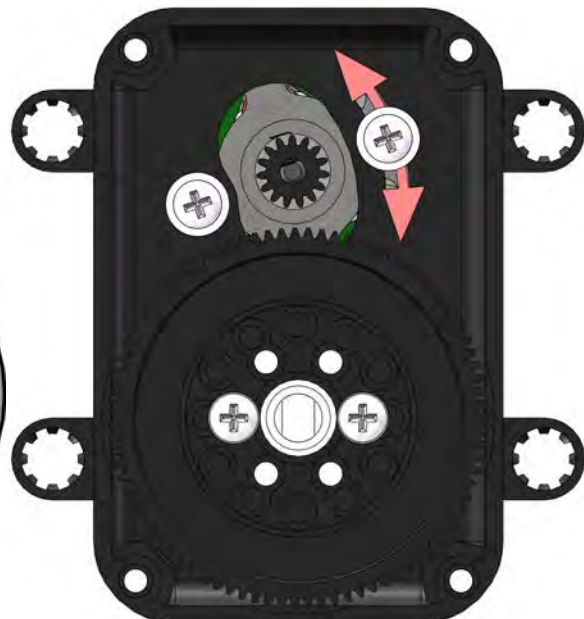

06

x4
#4-40 x 3/4" SCREW

x4
#4 WASHER

x4
#4-40 NUT

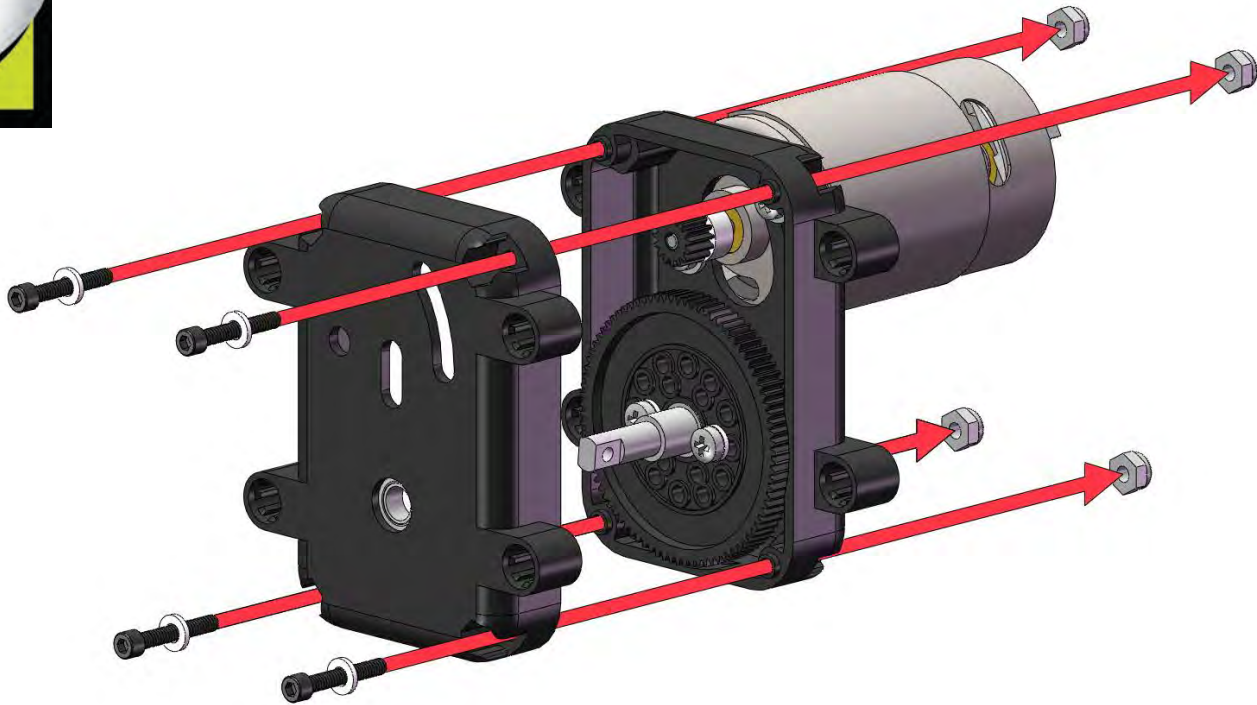

07

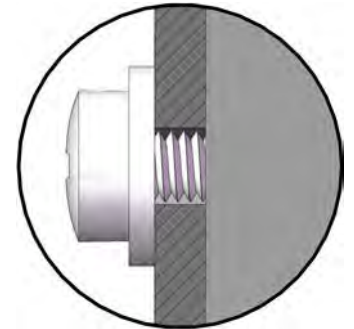
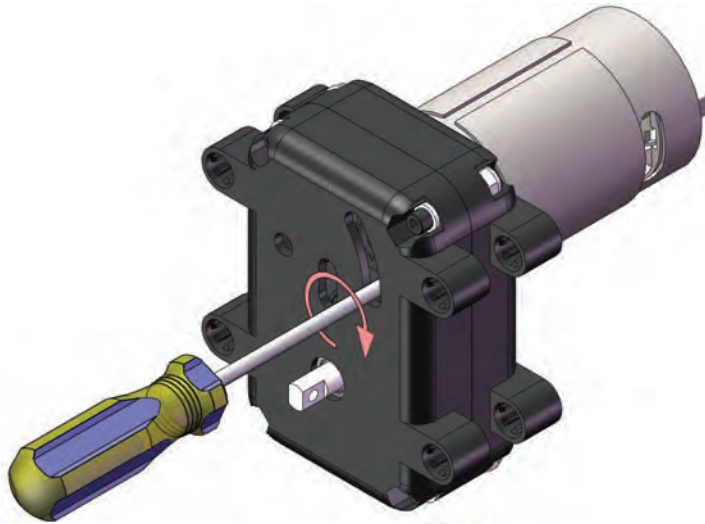

ADJUST MOTOR SCREWS
UNTIL GEARS MESH
SMOOTHLY, THEN TIGHTEN



WHEN ALIGNING THE GEARS TOGETHER MAKE SURE THEY ARE ABOUT A PAPER'S THICKNESS APART SO THEY MESH SMOOTHLY. DO NOT LEAVE THEM LOOSE OR PRESS THEM TOO TIGHT TOGETHER OR IT MAY DAMAGE THE GEARS OR PUT TOO MUCH STRESS ON THE MOTOR.

DIFFERENTIAL ASSEMBLY

HELPFUL INSTRUCTIONAL VIDEOS AVAILABLE AT: www.mymindsi.com

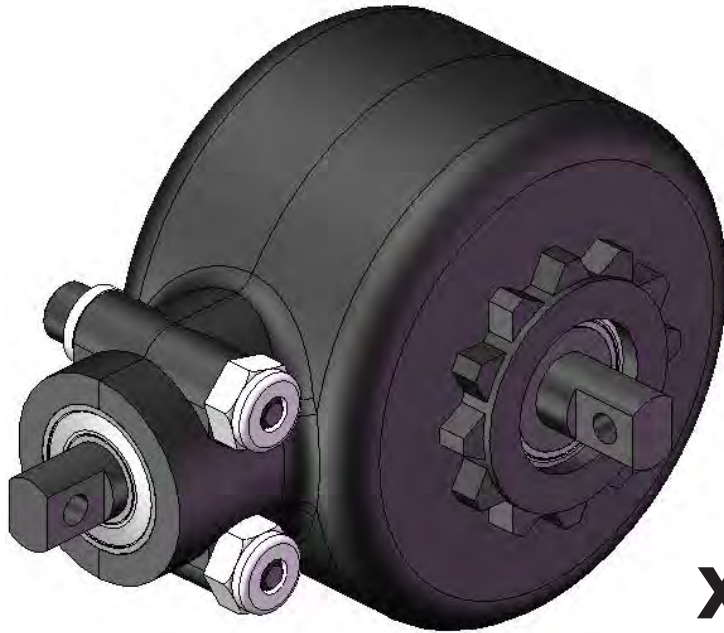

x2



KIT INCLUDES DIFFERENTIAL SHIMS -NOT USED



x1
RING GEAR



x1
DIFFERENTIAL SPOOL



x1
DIFFERENTIAL CARRIER



x1
CARRIER SHAFT



x4
CARRIER SCREW



x2
OUTPUT GEAR SHAFT



x2
SPIDER GEAR



OR

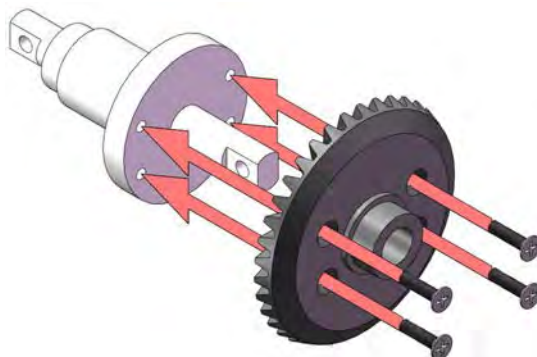

**BEST FOR:
HANDLING**

**BEST FOR:
TRACTION**

02

x1
PINION GEAR



x2
6x12x4mm BEARING



03

x2
DIFFERENTIAL CASE

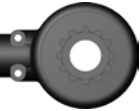

x2
10x15x4mm BEARING

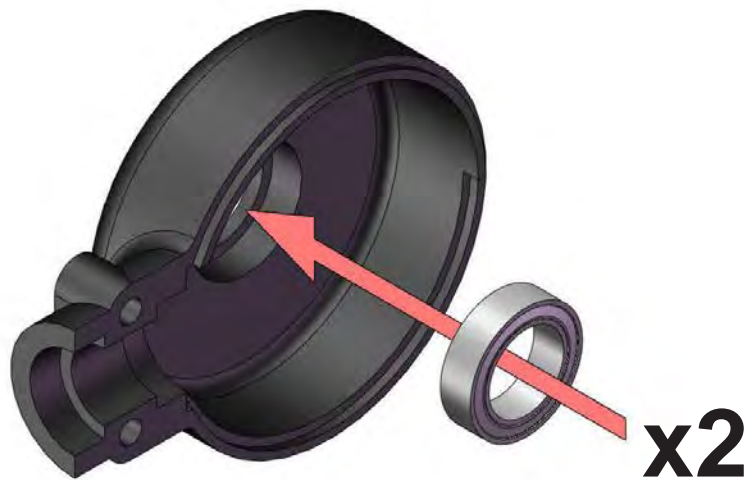

04



NOTE: MAKE SURE TO MARK WHICH SIDE THE RING GEAR IS ON FOR FUTURE REFERENCE.

05

x2
#4-40 x 3/4" SCREW



x2
#4 WASHER



x2
#4-40 NUT

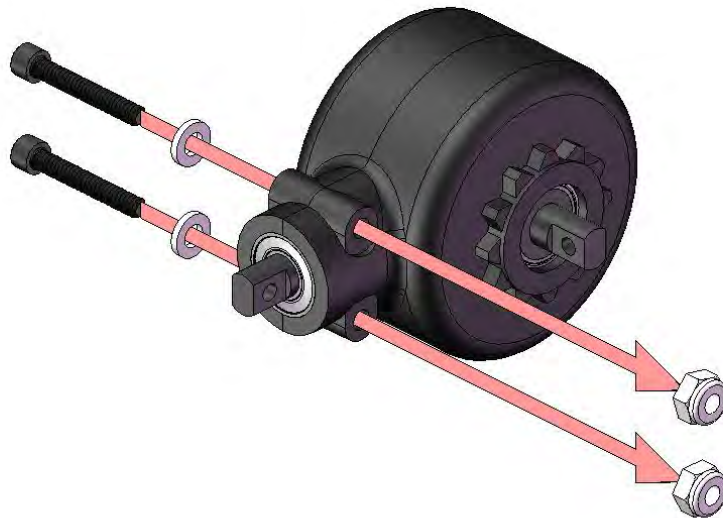

NOTE: MAKING SURE THE SCREW HEADS ARE ON THE SAME SIDE AS THE RING GEAR IS AN EASY WAY TO REMEMBER WHICH SIDE IT'S ON.

NOTICE:

THE ORIENTATION OF THE DIFFERENTIALS IS VERY IMPORTANT. MAKE SURE TO PAY CLOSE ATTENTION TO THE ASSEMBLY OF THE DIFFERENTIALS, ESPECIALLY WHICH SIDE THE RING GEAR IS ON, AS IT DETERMINES THE WHEELS DIRECTION OF ROTATION.

REFER TO THIS DIAGRAM WHEN ATTACHING THE AXLES TO THE FRAME, INSURING THE RING GEARS ARE IN THE APPROPRIATE LOCATIONS. HAVING THE DIFFERENTIALS IN BACKWARD WILL RESULT IN THE WHEELS ROTATING THE WRONG DIRECTION.

IT IS RECOMMENDED THAT YOU MANUALLY CHECK THE ROTATION OF THE DRIVETRAIN BEFORE INSTALLING THE ELECTRONICS. IF THEY ARE NOT ROTATING IN THE PROPER DIRECTION, THE AXLE MUST BE REMOVED AND THE DIFFERENTIAL TURNED UPSIDE-DOWN.

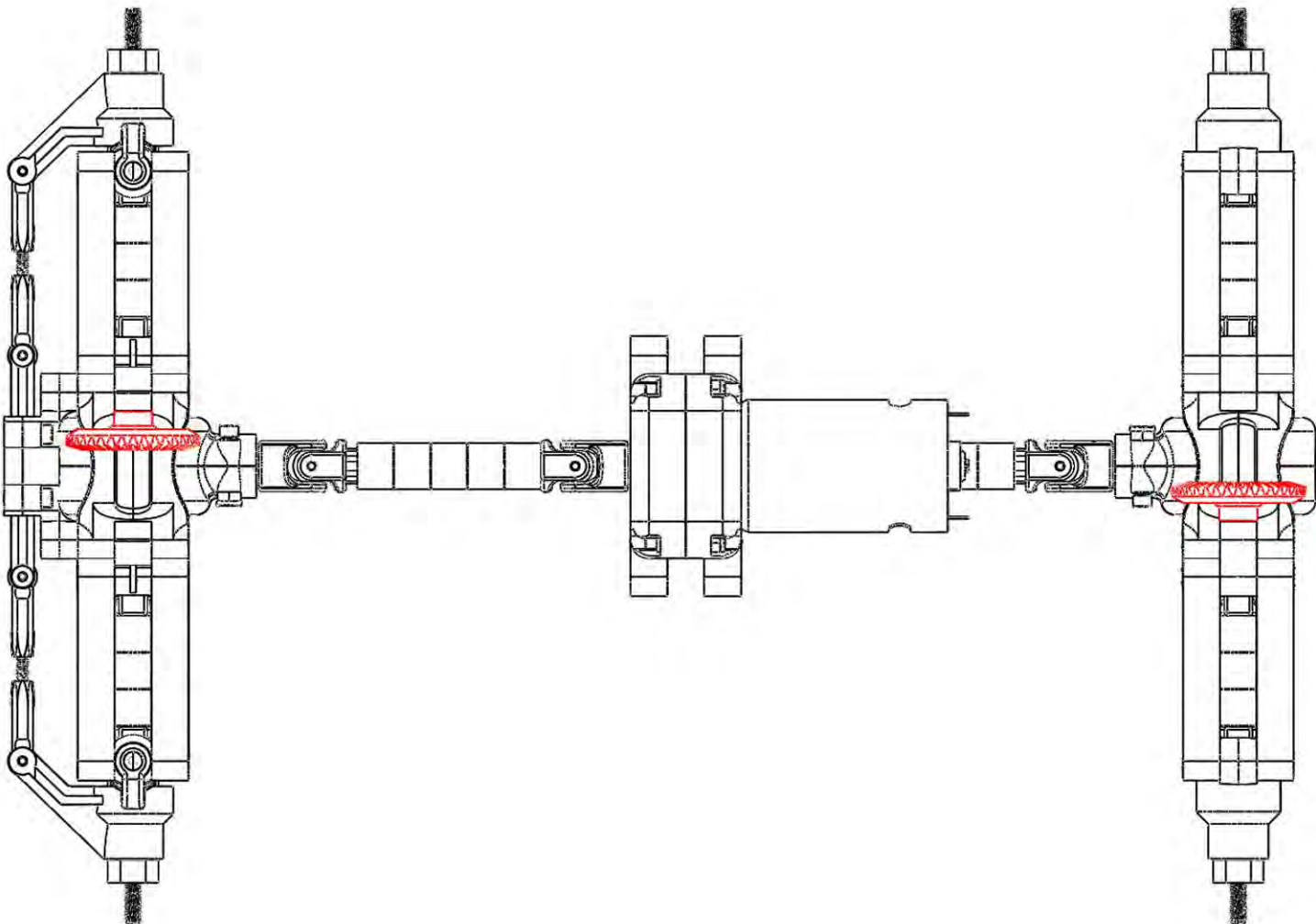

WHEEL & TIRE ASSEMBLY

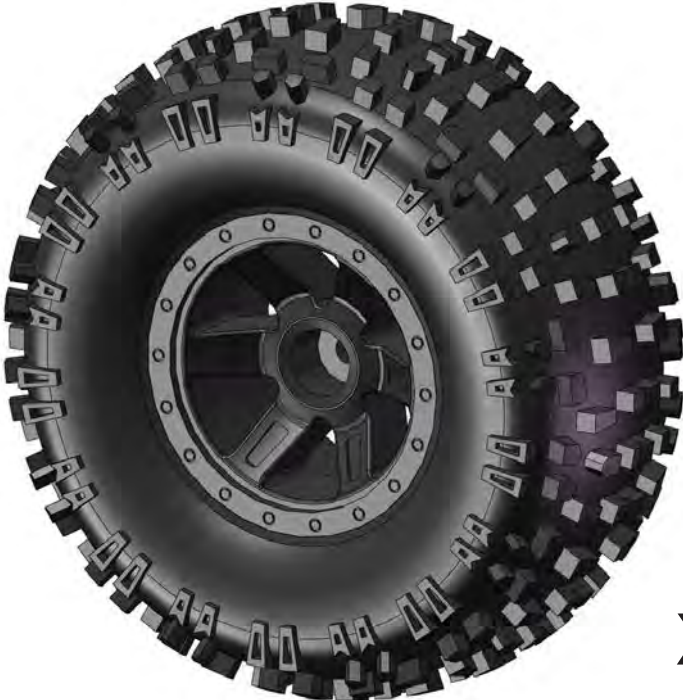

x4



x1
BADLANDS 2.2" TIRE



x1
DESPERADO WHEEL





NOTE: MAKE SURE BOTH SIDES OF THE TIRE ARE PROPERLY SEATED ON THE RIM.

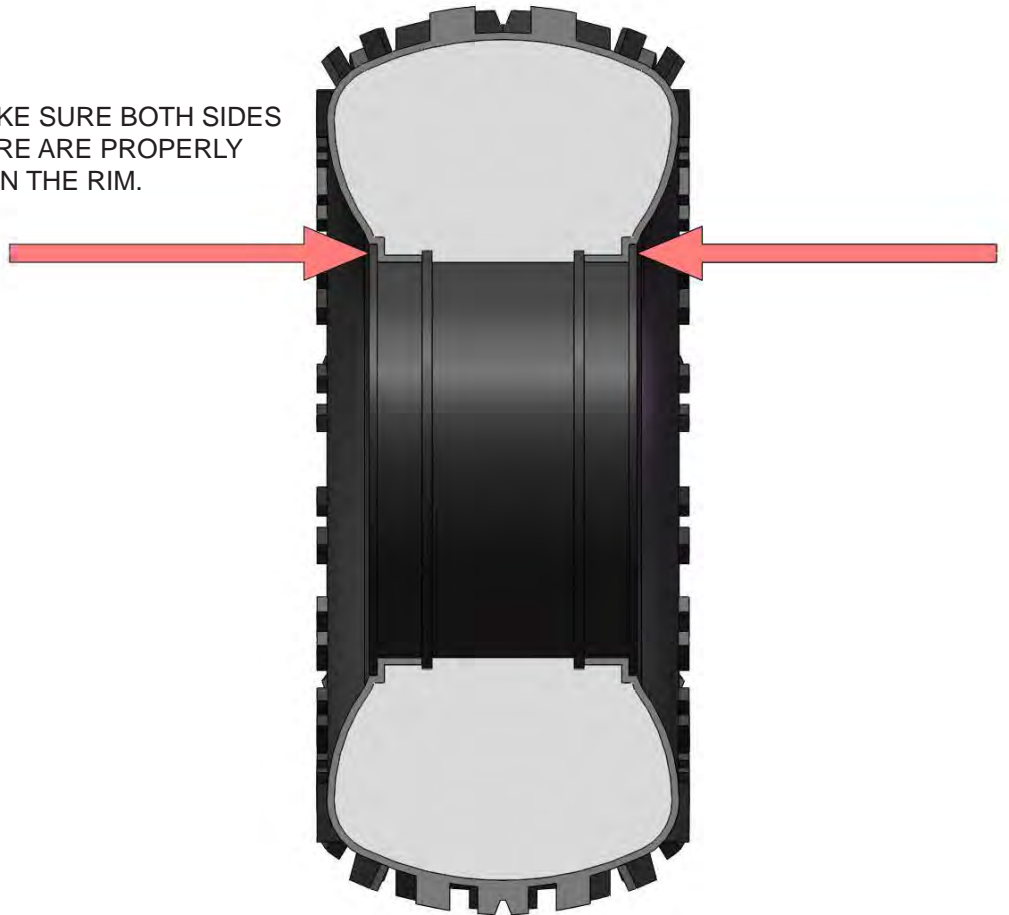

OPTIONAL: IF YOU WOULD LIKE TO GLUE YOUR TIRES DOWN, PLACE A SMALL BEAD OF CA GLUE BETWEEN THE WHEEL AND TIRE. BE SURE TO PLACE TIRE BEAD BACK ONTO THE RIM PROPERLY.



LEAF SPRING SUSPENSION





x2
13-BEAM



x1
9-BEAM



x2
7-BEAM



x2
3-LOCK



x2
2-LOCK



x3
15-BEAM



x4
2-LOCK





x2
2-LOCK

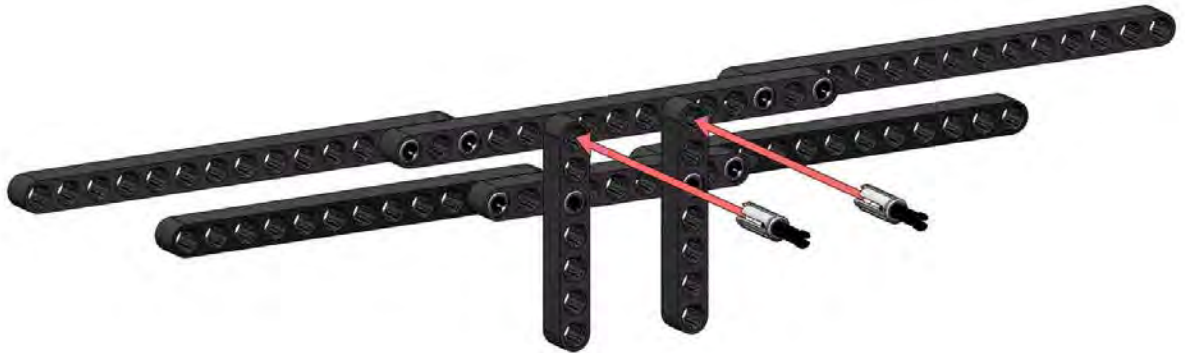

x1
11-BEAM



x2
4-BEAM



x2
4-45 BEAM



x4
2-LOCK





x2
2-LOCK



x2
REPEAT STEPS 1-6

07

x6
TRANSITION



x2
3-LOCK



x4
2-LOCK



08

x4
3-LOCK



x2
2-LOCK

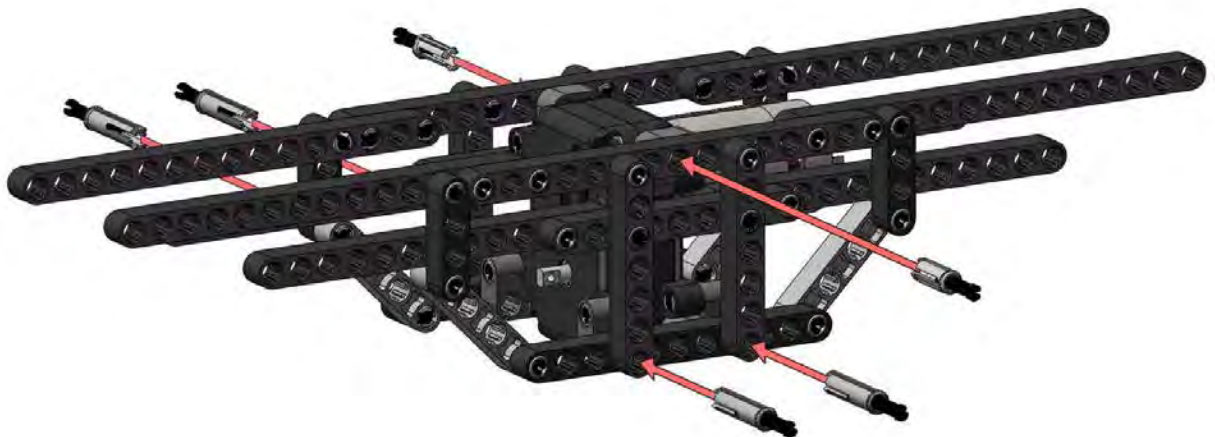

09

x2
13-BEAM



x8
TRANSITION



x8
2-LOCK

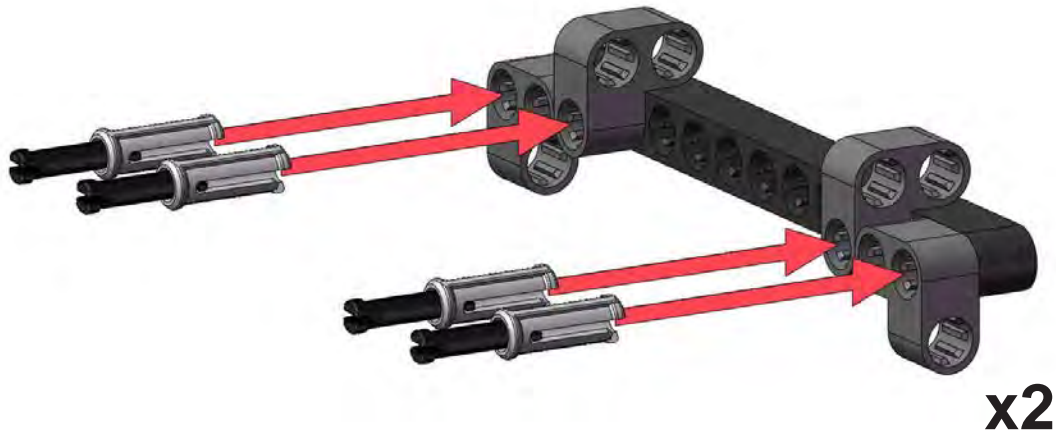

10

x4
2-LOCK

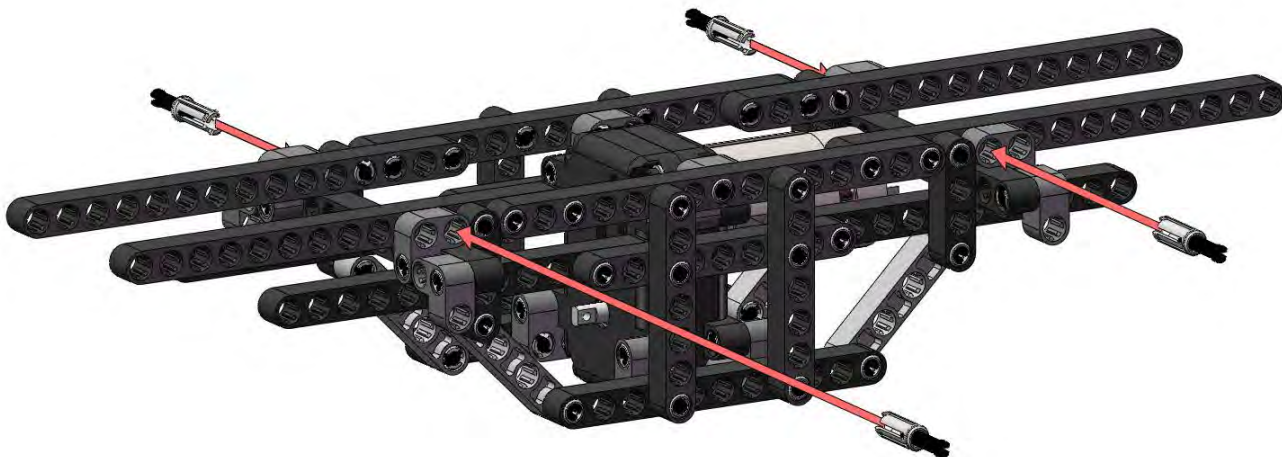

11

x4
3-BEAM

x4
2-LOCK

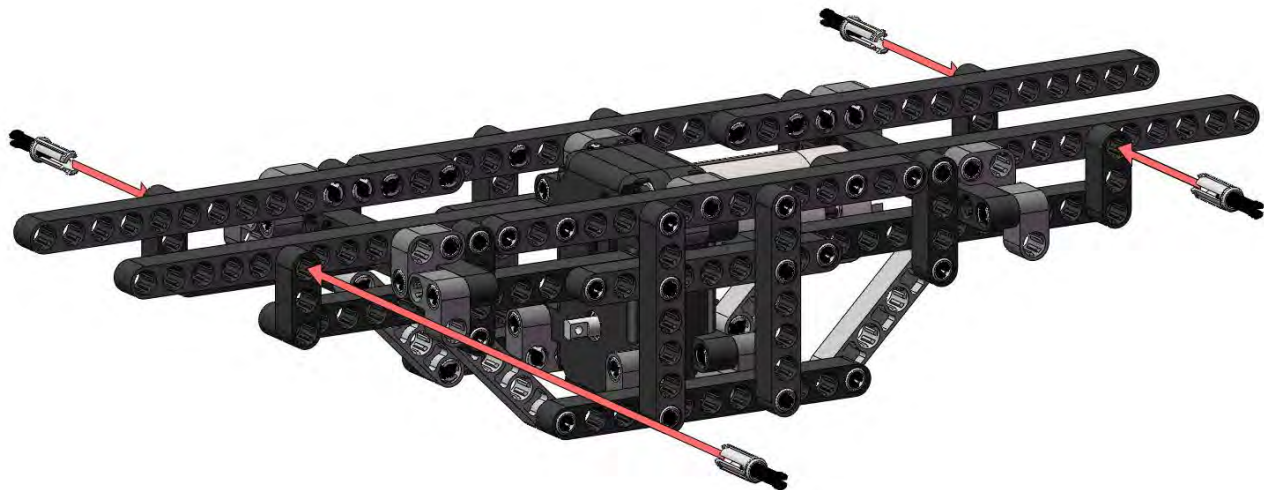

12

x1
BATTERY CAP

x2
2-LOCK

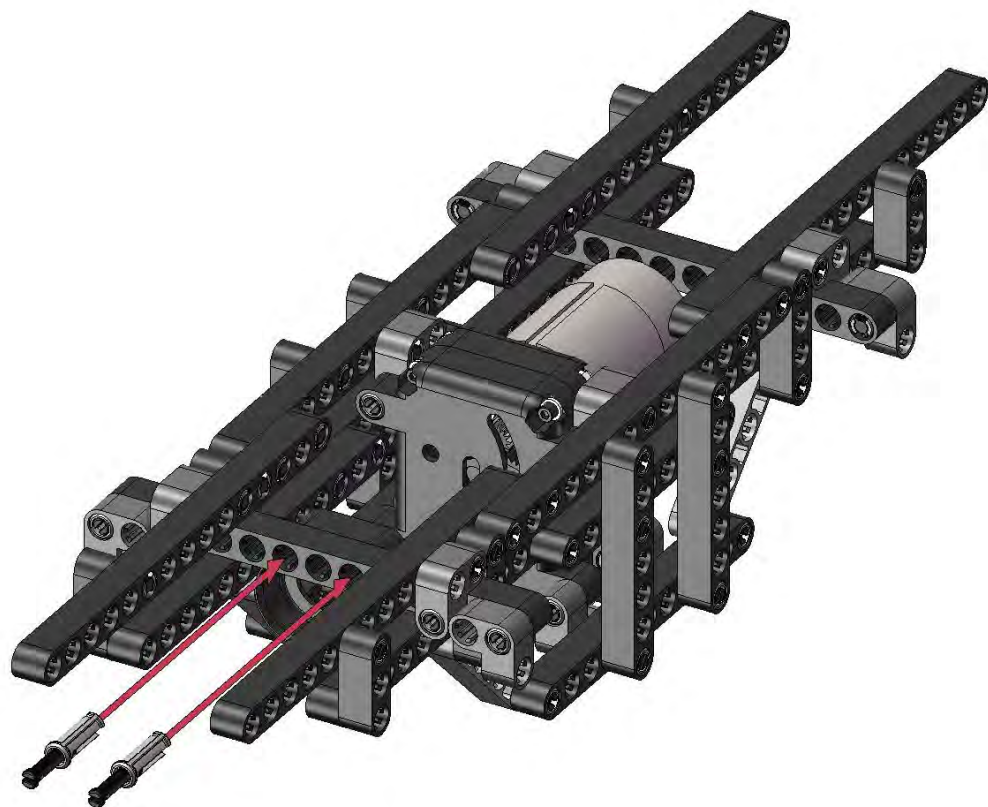

13

x1
15-BEAM



x1
3-45 BEAM



x1
TRANSITION



x1
3-LOCK



14

x1
TRANSITION



x1
2-LOCK

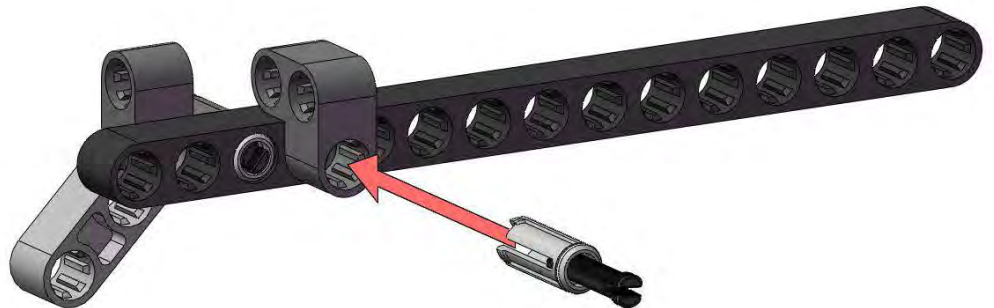

15

x1
4-BEAM

x1
2-LOCK



16

x3
4-BEAM

x1
3-LOCK

x1
3-ROTATE



17

x1
15-BEAM



x1
3-45 BEAM



x1
TRANSITION



x1
3-LOCK

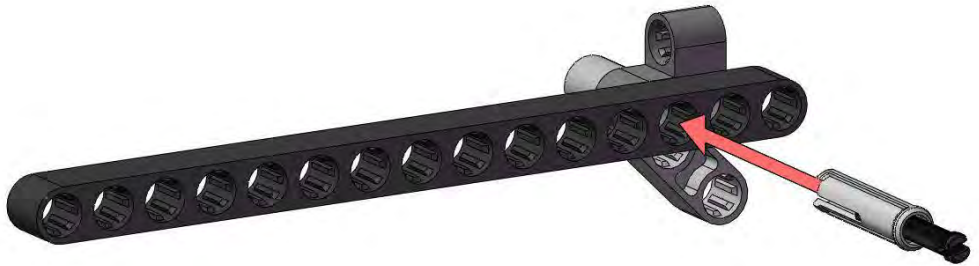

18

x1
TRANSITION



x1
2-LOCK





x1
4-BEAM



x1
2-LOCK



x3
4-BEAM



x1
3-LOCK



x1
3-ROTATE



21

x1
13-BEAM



x2
TRANSITION



x1
BATTERY CAP



x2
3-LOCK



x4
2-LOCK



22

x4
3-LOCK



x4
2-LOCK

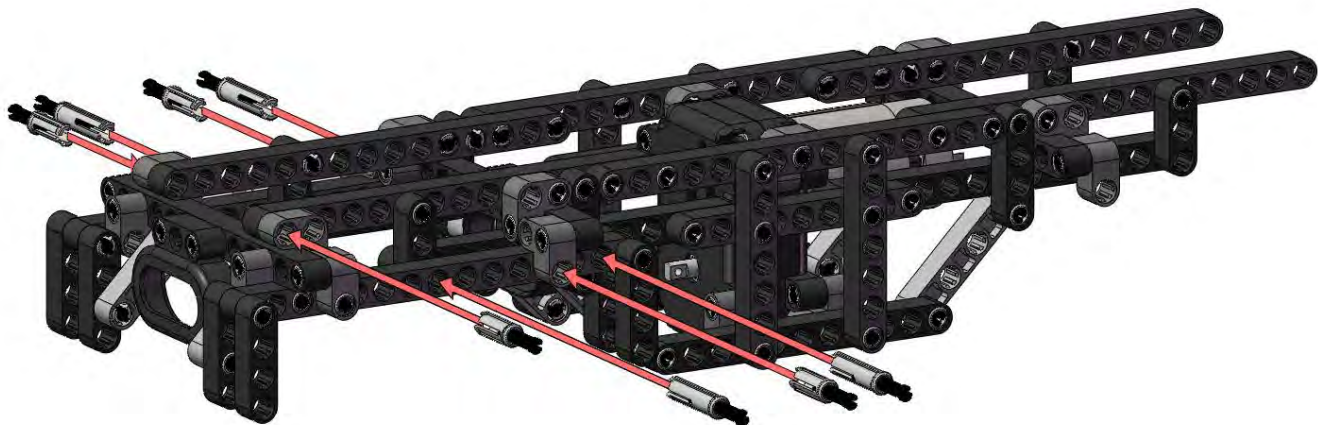

23

x2
4-BEAM



x2
2-LOCK



24

x1
15-BEAM



x2
TRANSITION



x2
2-LOCK

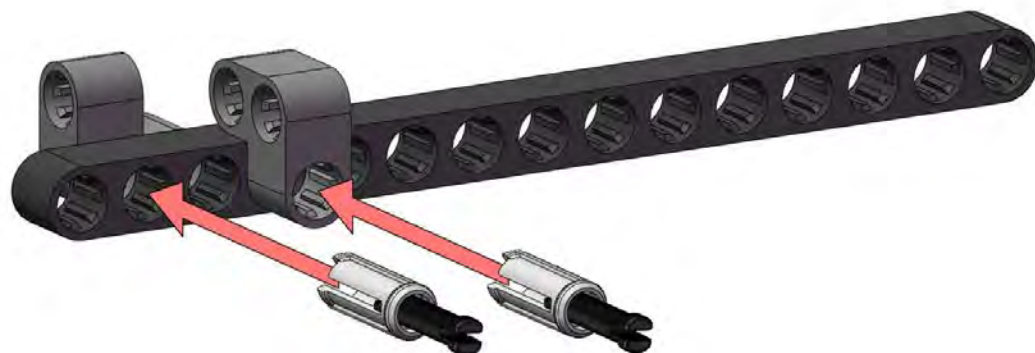

25

x2
4-BEAM



x1
2-BEAM



x1
3-LOCK



x1
3-ROTATE



26

x1
15-BEAM



x2
TRANSITION



x2
2-LOCK

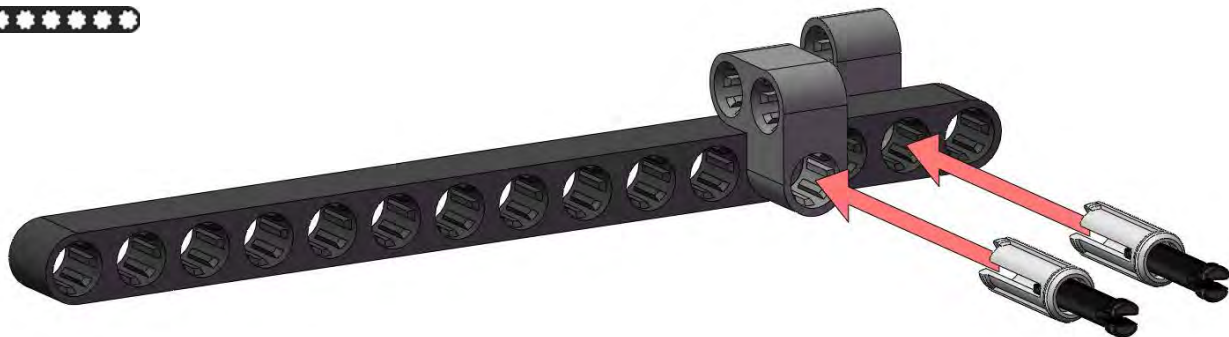

27

x2
4-BEAM



x1
2-BEAM



x1
3-LOCK



x1
3-ROTATE



28

x1
13-BEAM



x2
TRANSITION



x2
3-LOCK



x2
2-LOCK

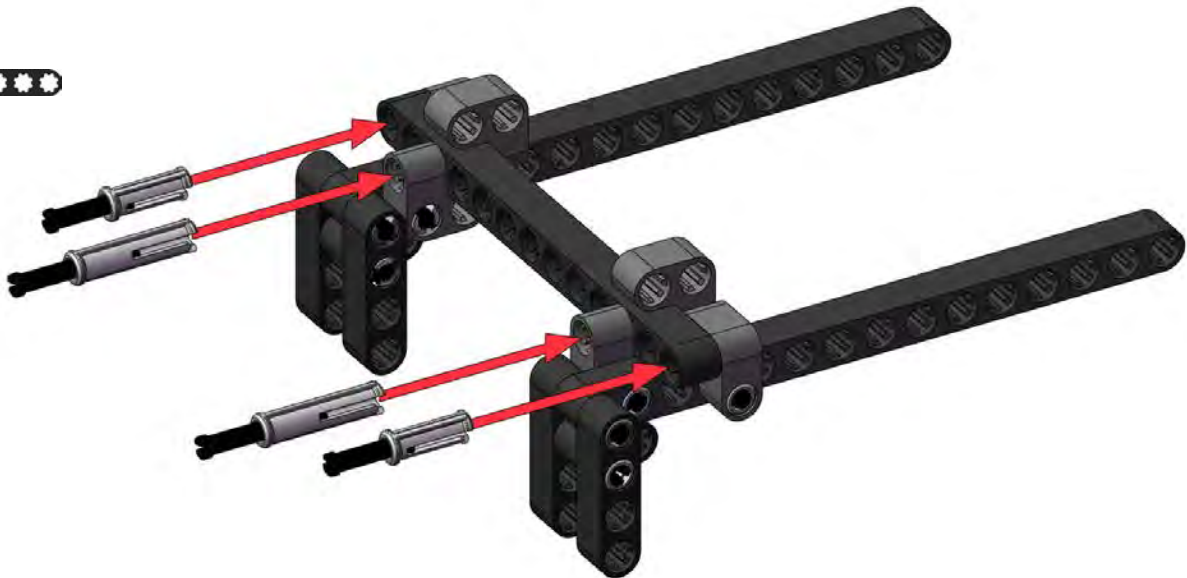

29

x4
3-LOCK

x4
2-LOCK

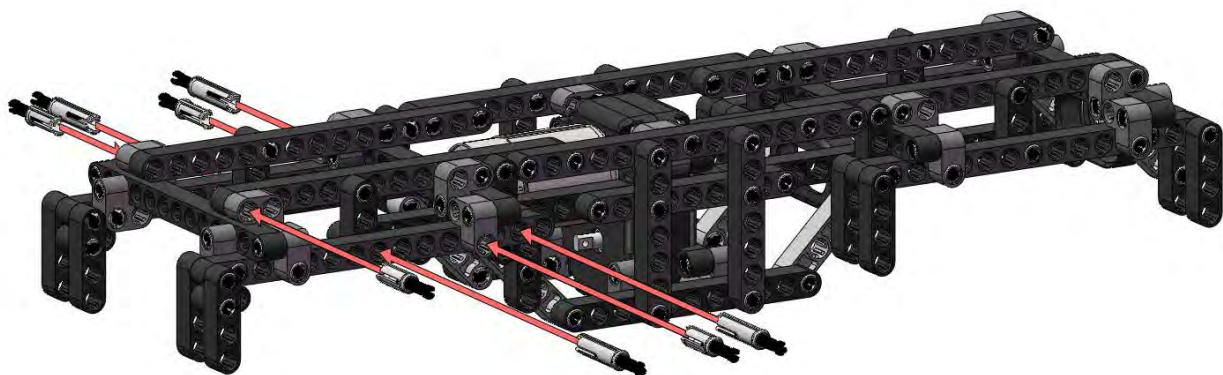

30

x2
4-BEAM

x2
3-LOCK

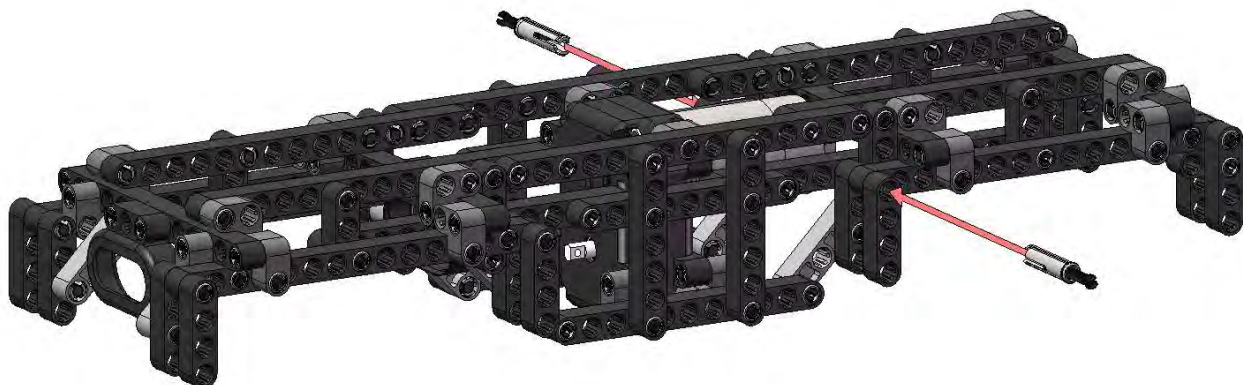

31

x2
LEAF SPRING

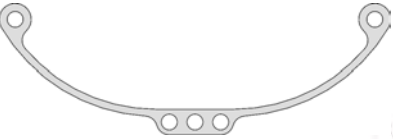

x8
TRANSITION



x4
3-ROTATE

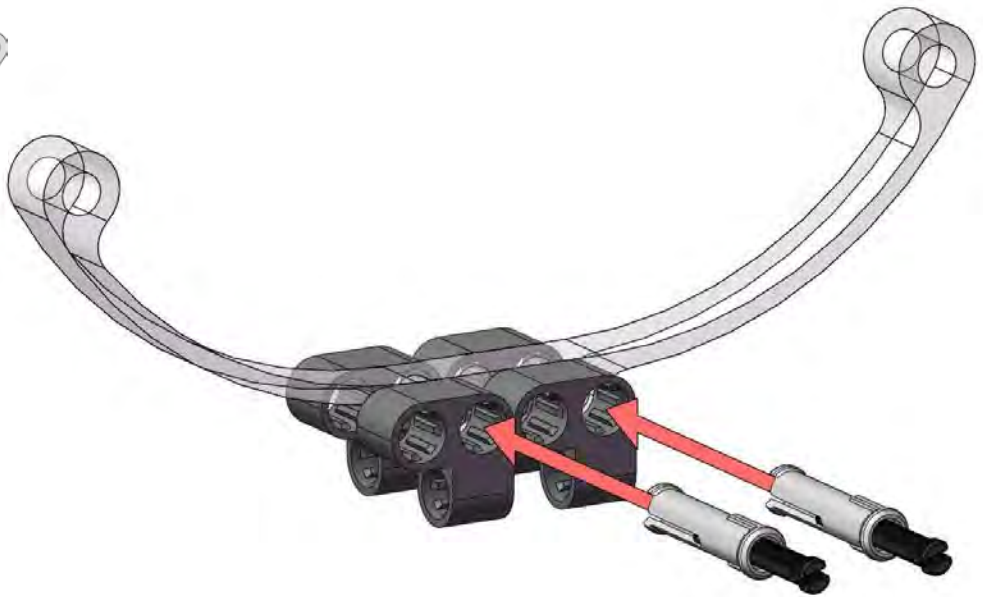

x2

32

x2
LEAF SPRING

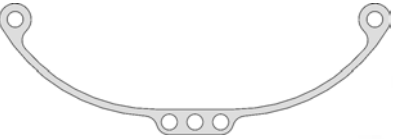

x8
TRANSITION



x4
3-ROTATE

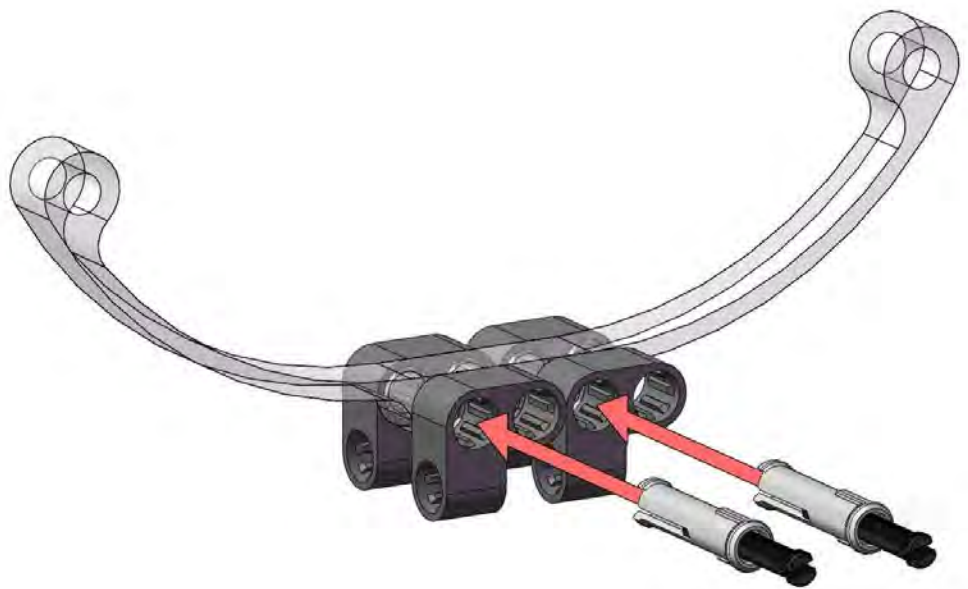

x2



x2
3-DRIVELINE



x2
M4 WHEEL END SHAFT



x4
U-JOINT SET SCREW



x1
AXLE HOUSING



x1
STEERING BRACKET



x4
1.5-LOCK

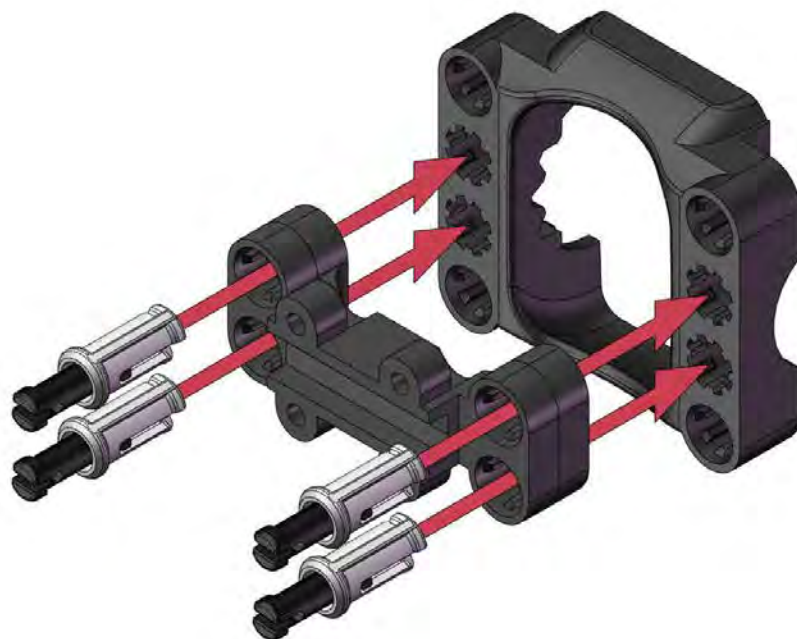



x1
STEERING BAR



x1
STEERING PLATE



x4
#4-40 x 3/8" SCREW

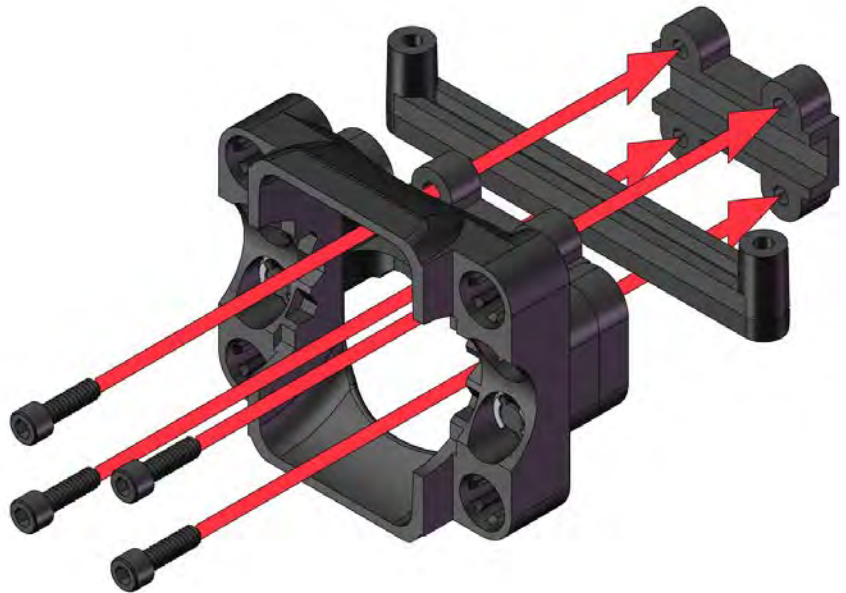

x1
AXLE HOUSING



x2
SERVO MOUNT



x2
2-BEAM



x4
3-LOCK

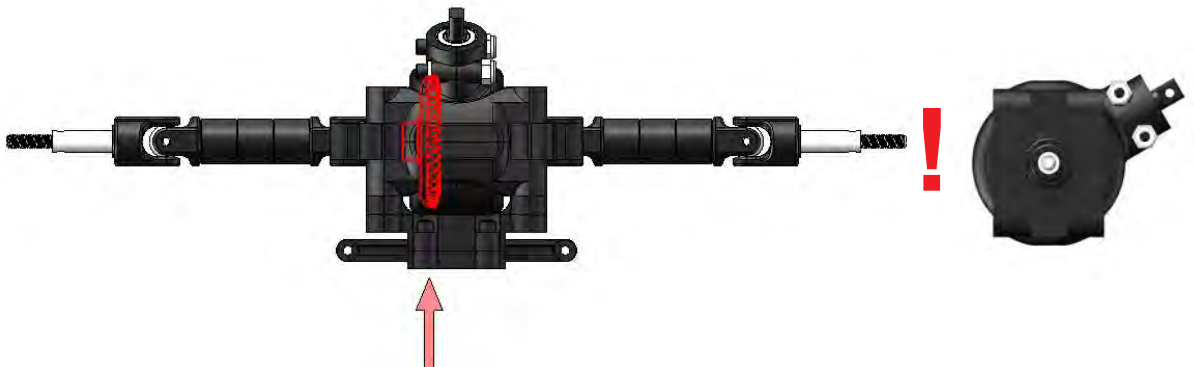
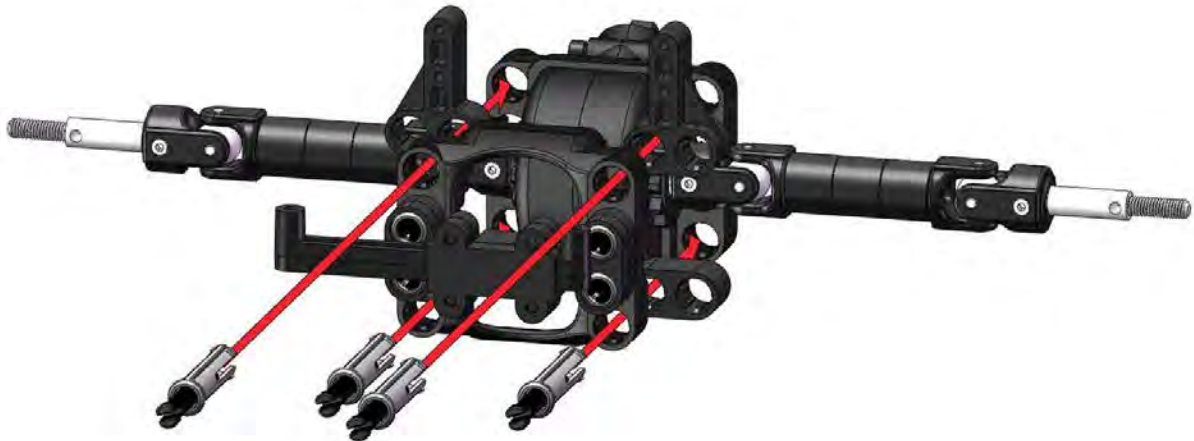

37

x1
HS-485HB SERVO



x4
SERVO BUSHING



x4
SERVO BUSHING SLEEVE

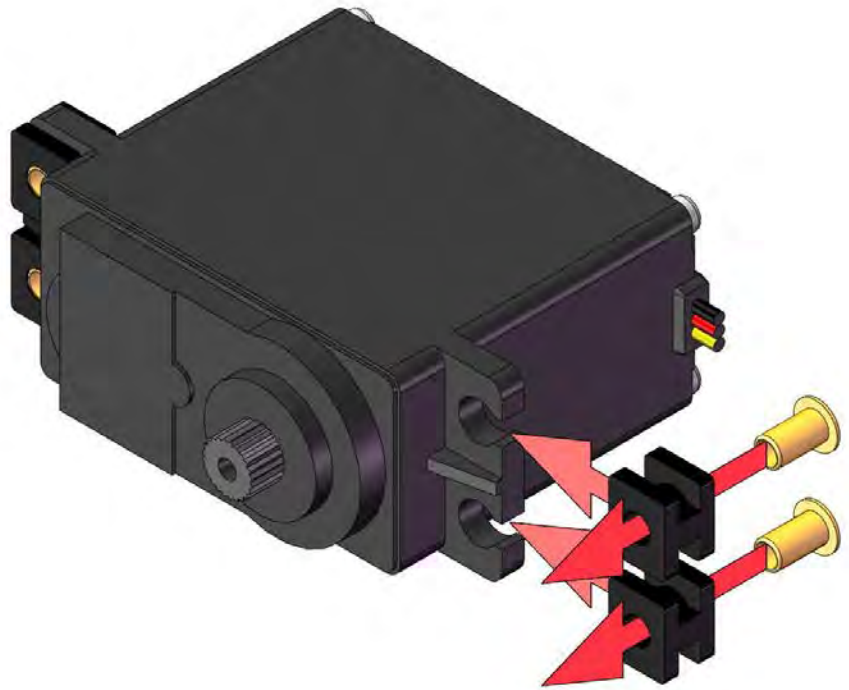

38

x4
#2-32 x 5/8" SCREW



x4
#2 WASHER

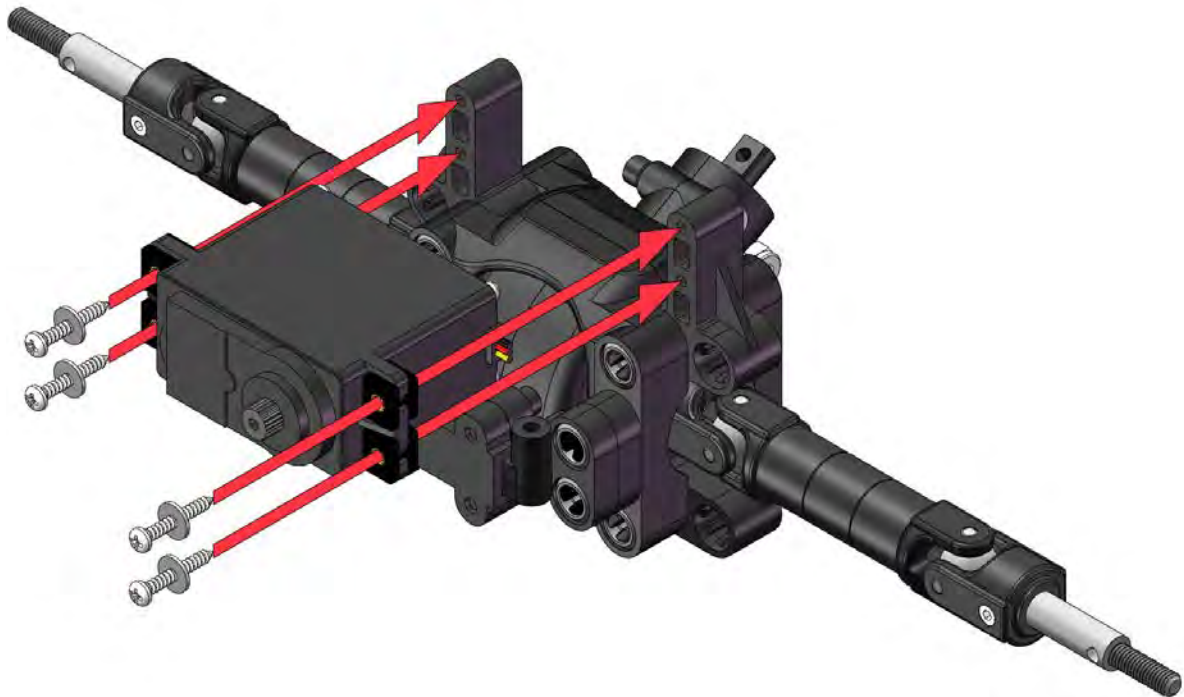

39

x2
FRONT WHEEL HUB



x2
FRONT WHEEL KNUCKLE



x8
6-BEAM



x4
3-LOCK



x4
6x12x4mm BEARING

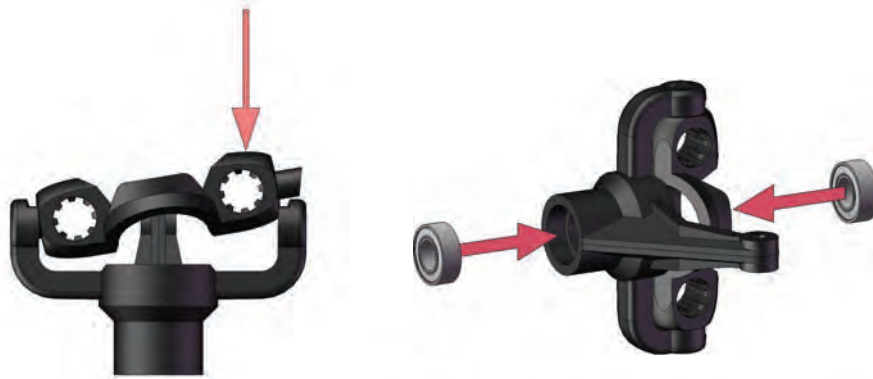

40

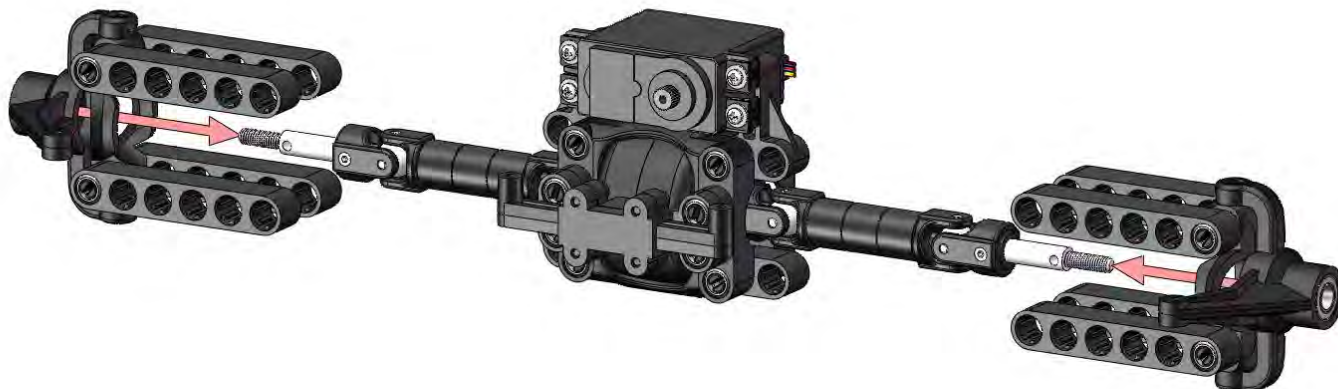

41

x4
3-LOCK

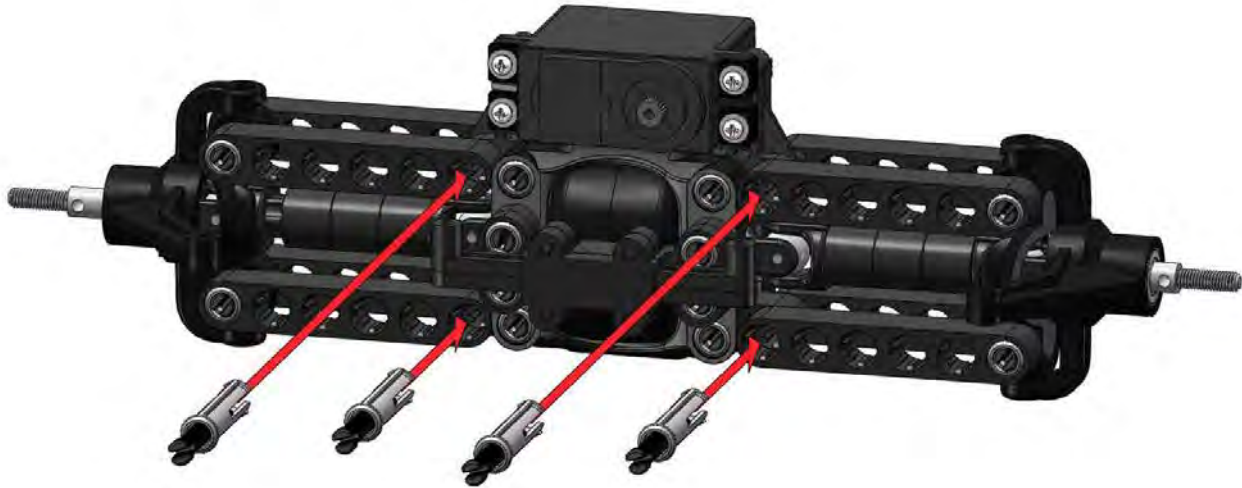

42

x5
3/16" BALL STUD

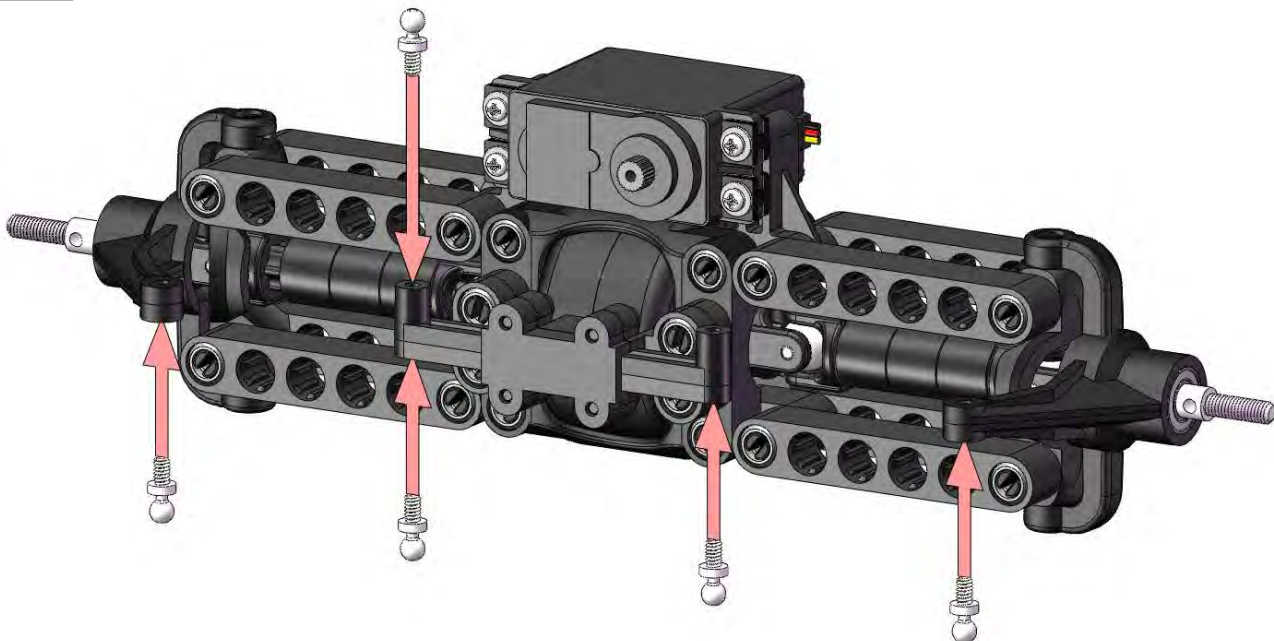



x2
#4-40 x 1-1/2" THREAD ROD



x4
23mm BALL CUP



=

1:1 SCALE



x2

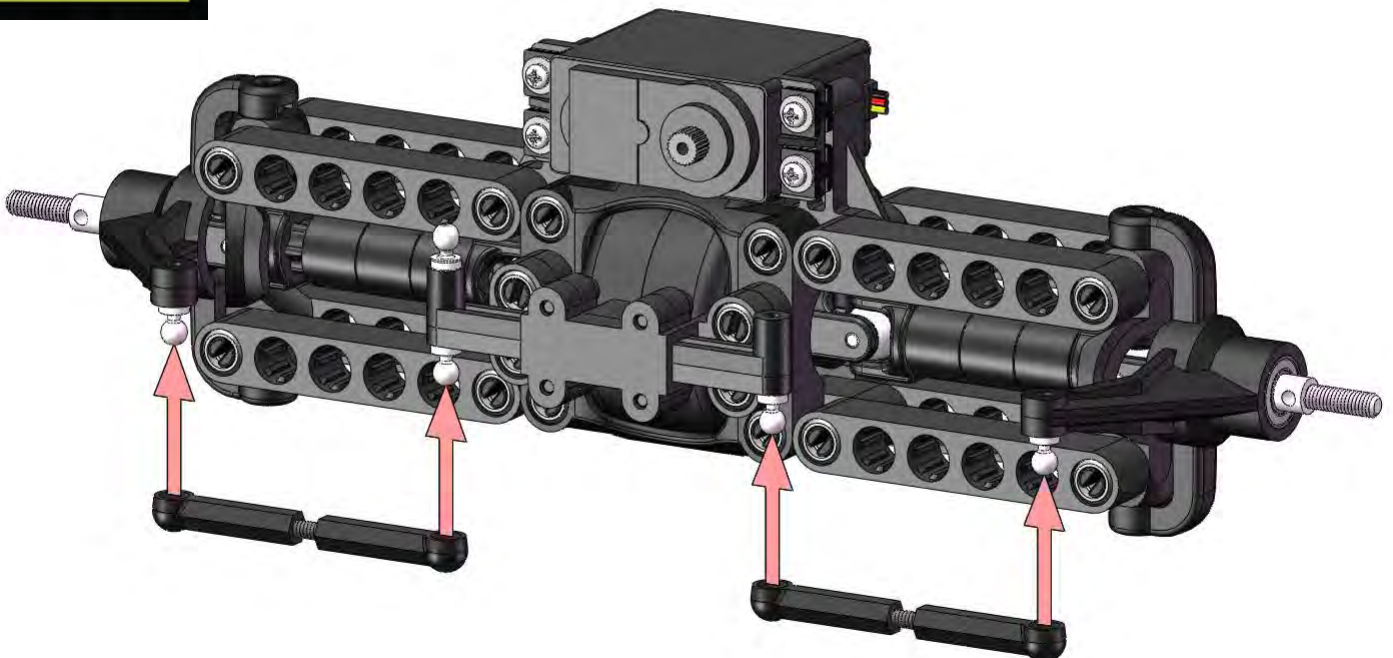



x1
#4-40 x 1" THREAD ROD

x2
18mm BALL CUP



=

1:1 SCALE



x1
STEERING SERVO HORN

x1
3/16" BALL STUD



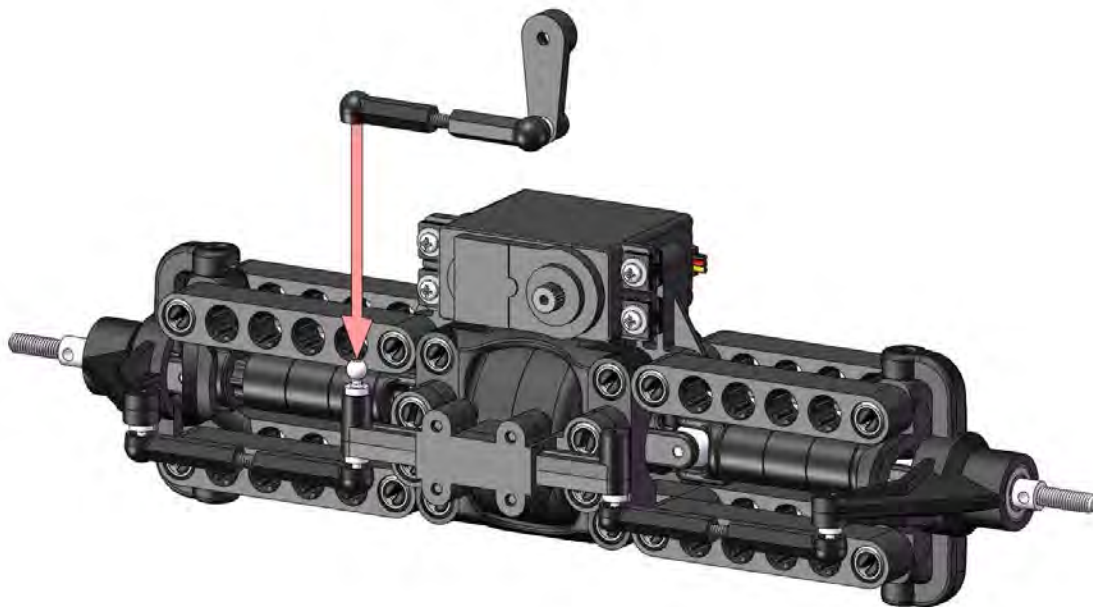

NOTE: REFER TO RADIO CONTROL SYSTEM INSTRUCTION MANUAL FOR PROPER SERVO SET-UP AND ADJUSTMENT



x1
SERVO HORN SCREW

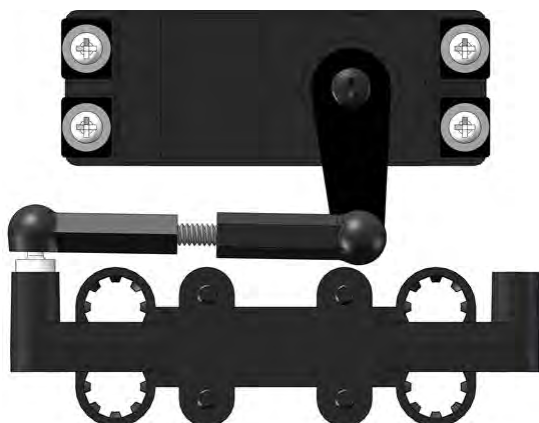
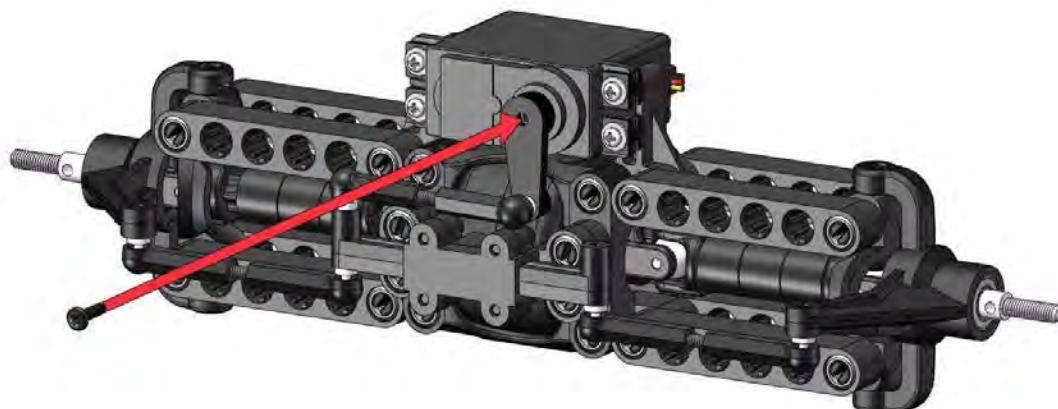

49

x8
2-LOCK

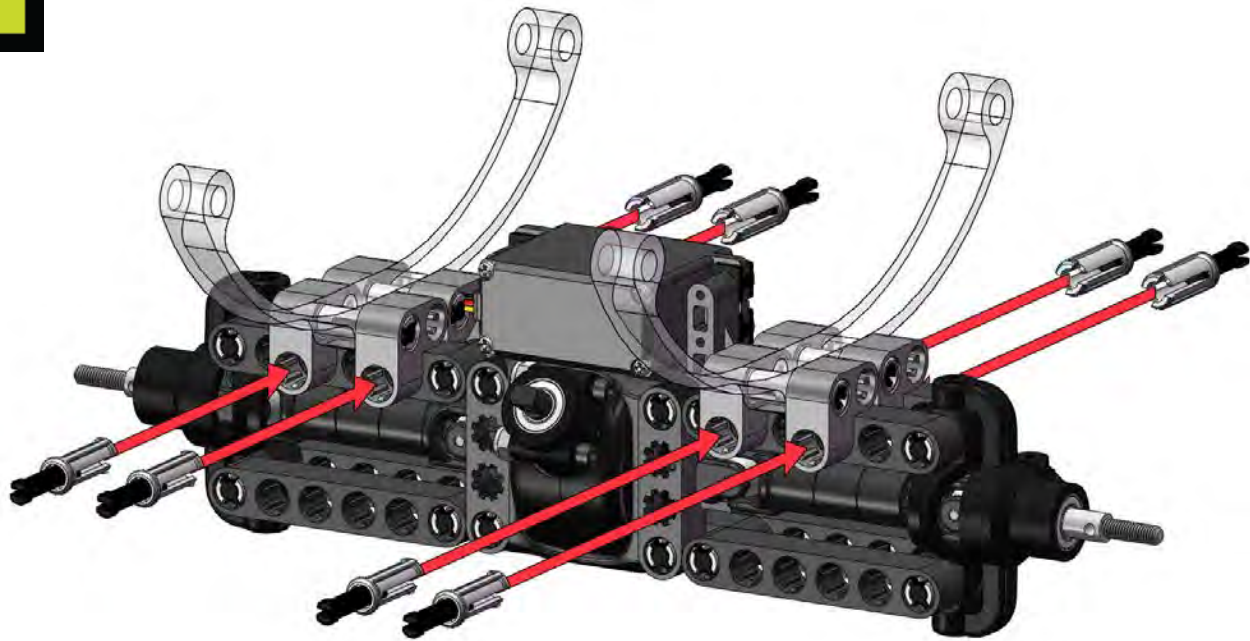

50

x2
12mm WHEEL NUT

x2
2.5x10mm DOWEL PIN

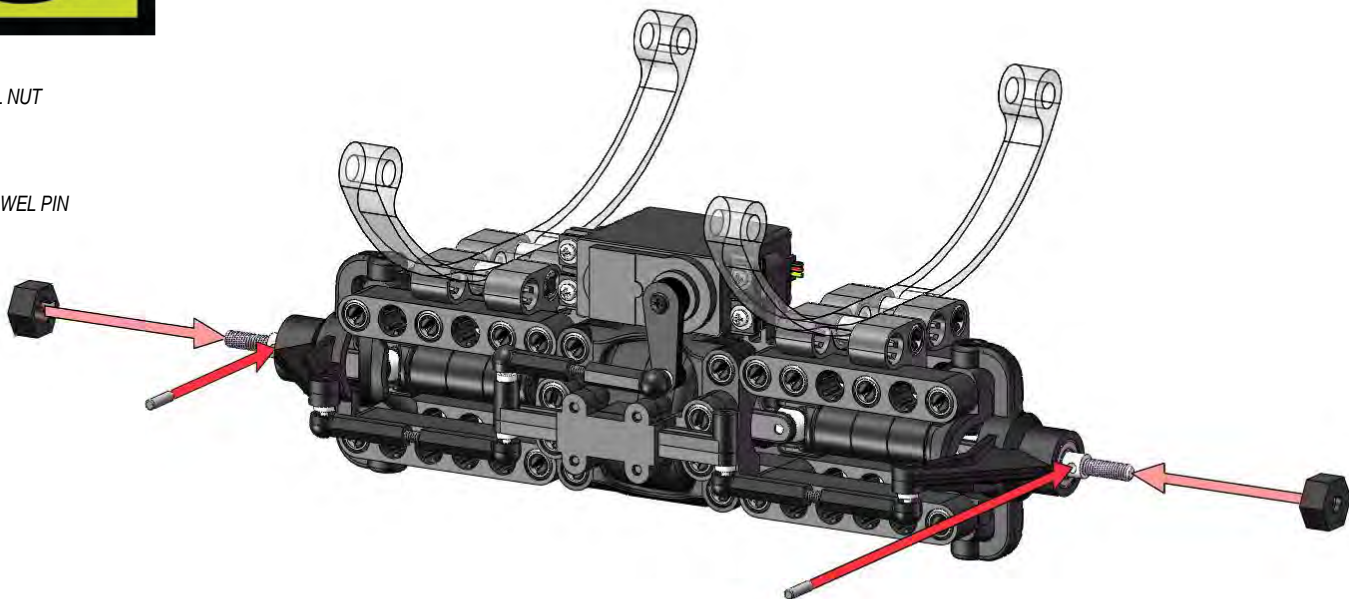

51

x2
3-DRIVELINE



x2
M4 WHEEL END SHAFT



x4
U-JOINT SET SCREW

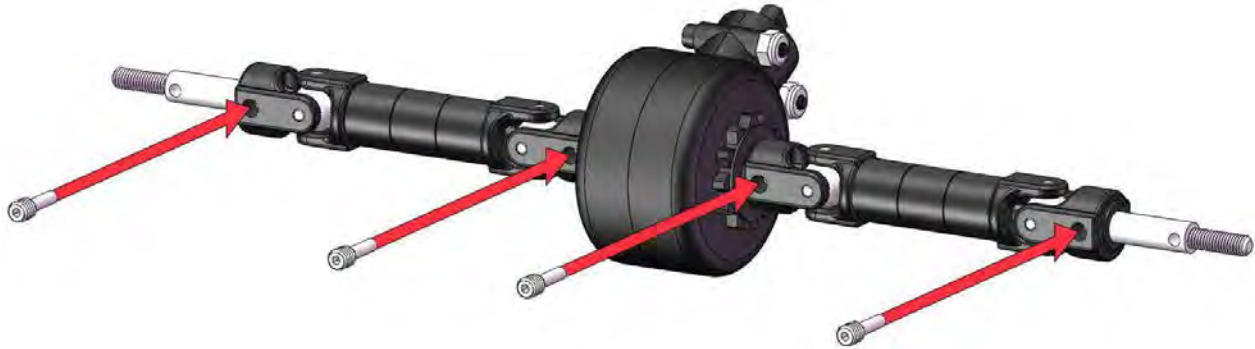

52

x2
AXLE HOUSING



x4
2-BEAM



x4
3-LOCK

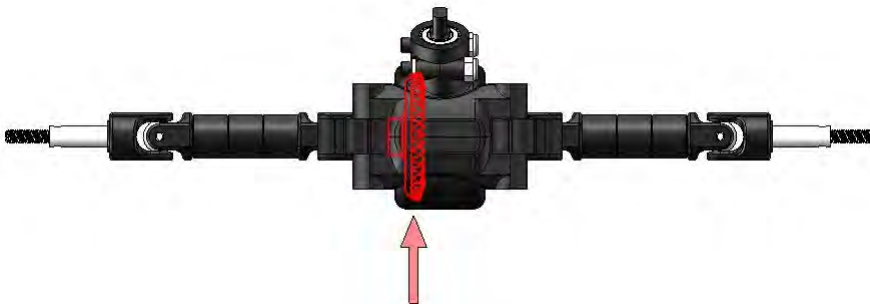

53



x2
REAR WHEEL HUB



x8
6-BEAM



x4
3-LOCK



x4
6x12x4mm BEARING

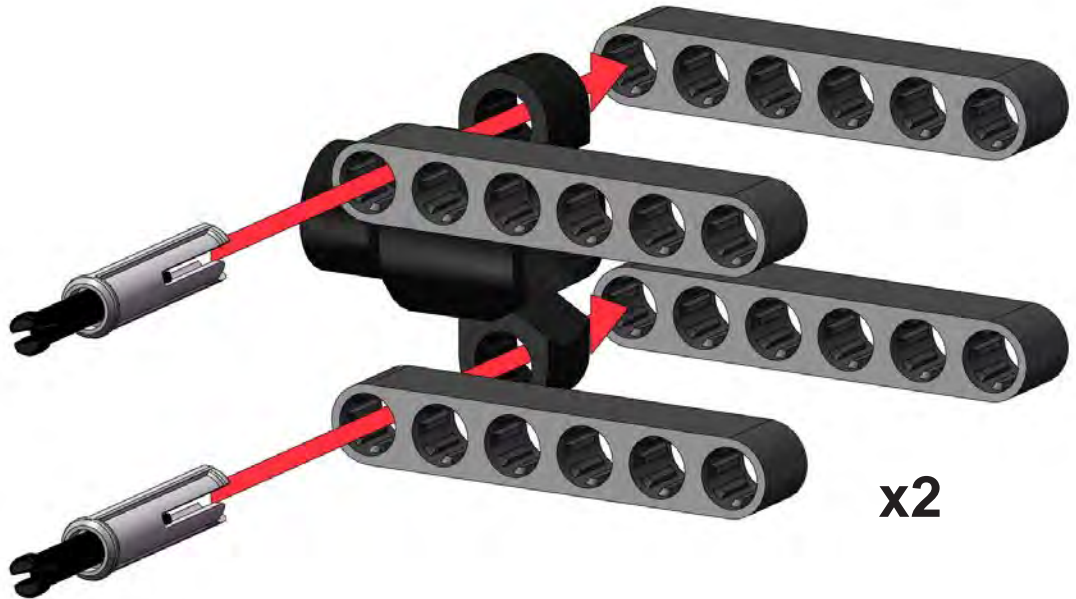

54





x4
3-LOCK

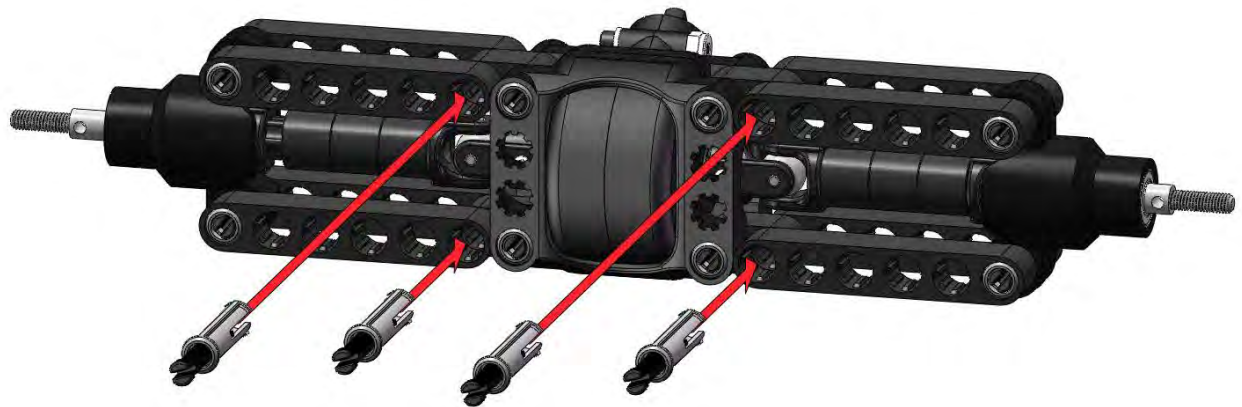

x8
2-LOCK

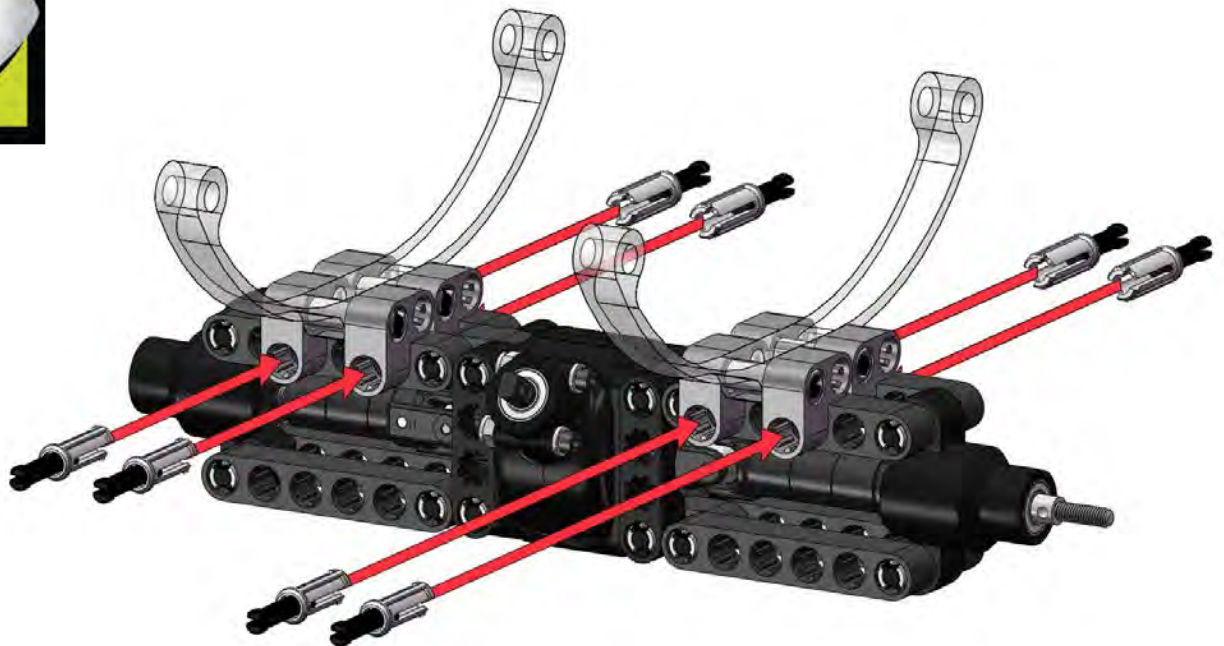

57

x2
12mm WHEEL NUT

x2
2.5x10mm DOWEL PIN

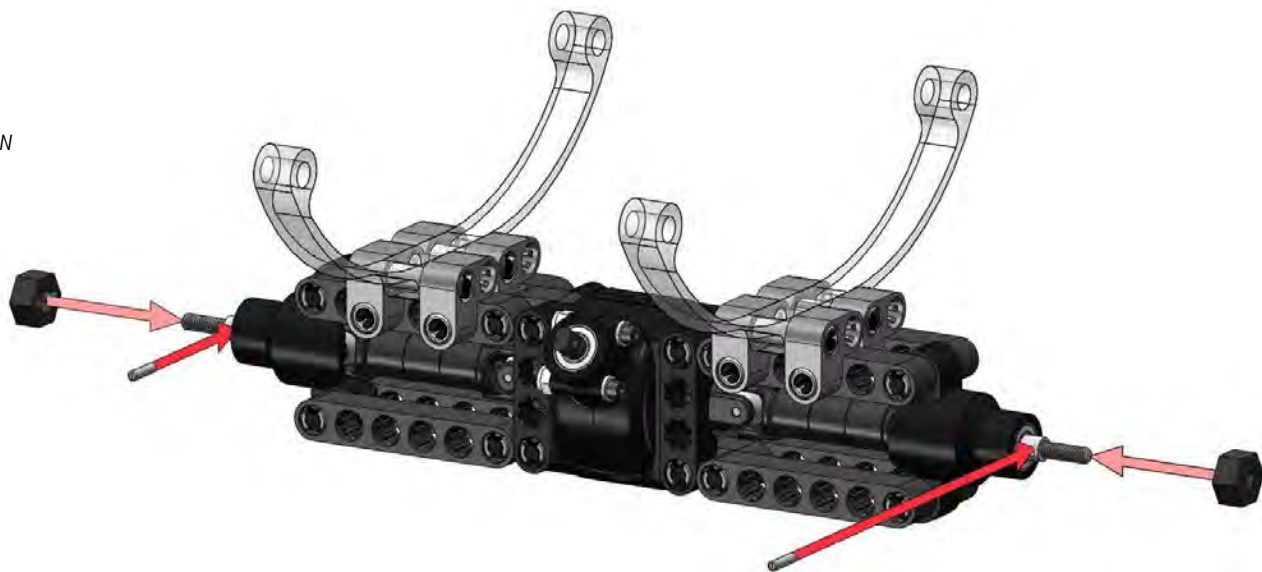

58

x8
3-ROTATE

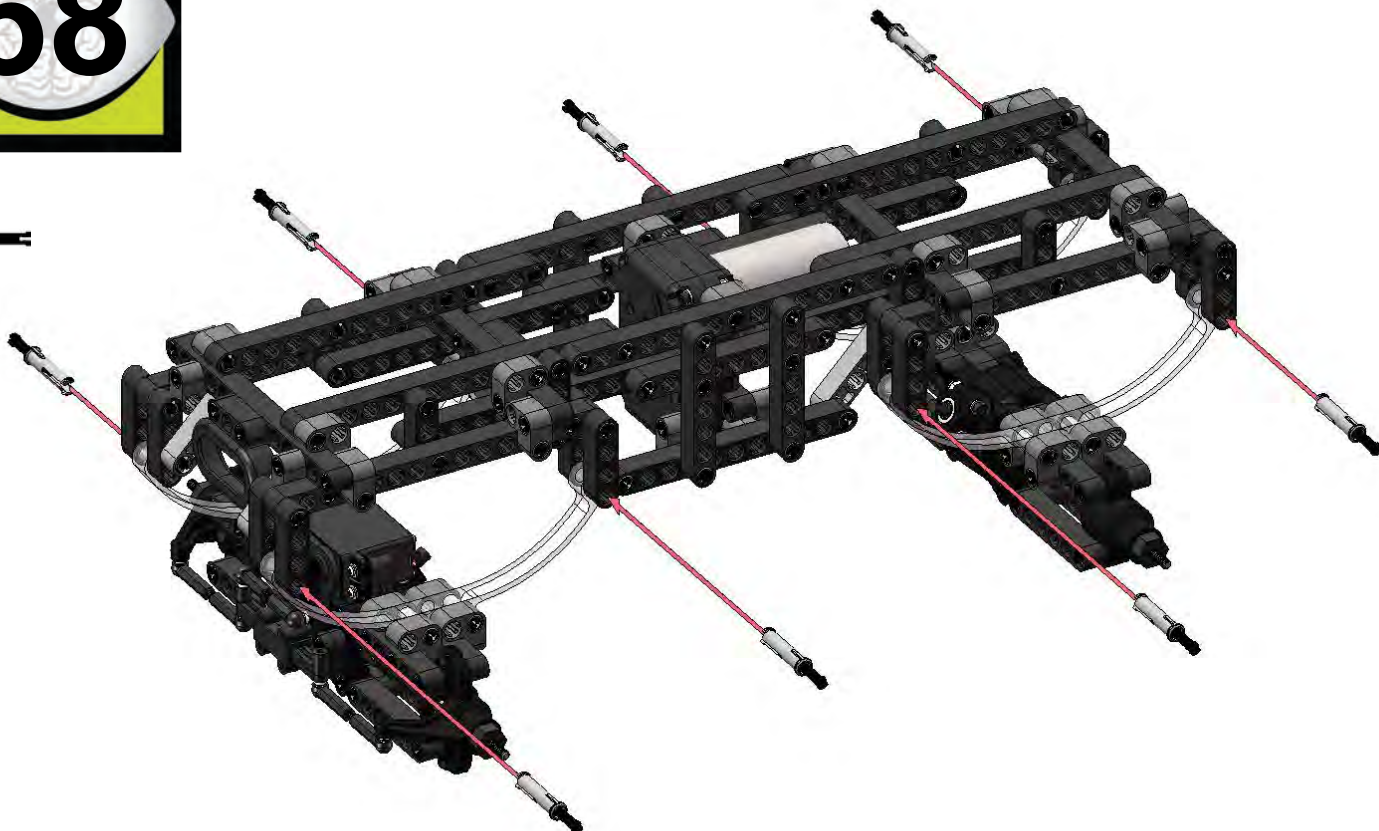

59

x2
5-DRIVELINE



x4
U-JOINT SET SCREW

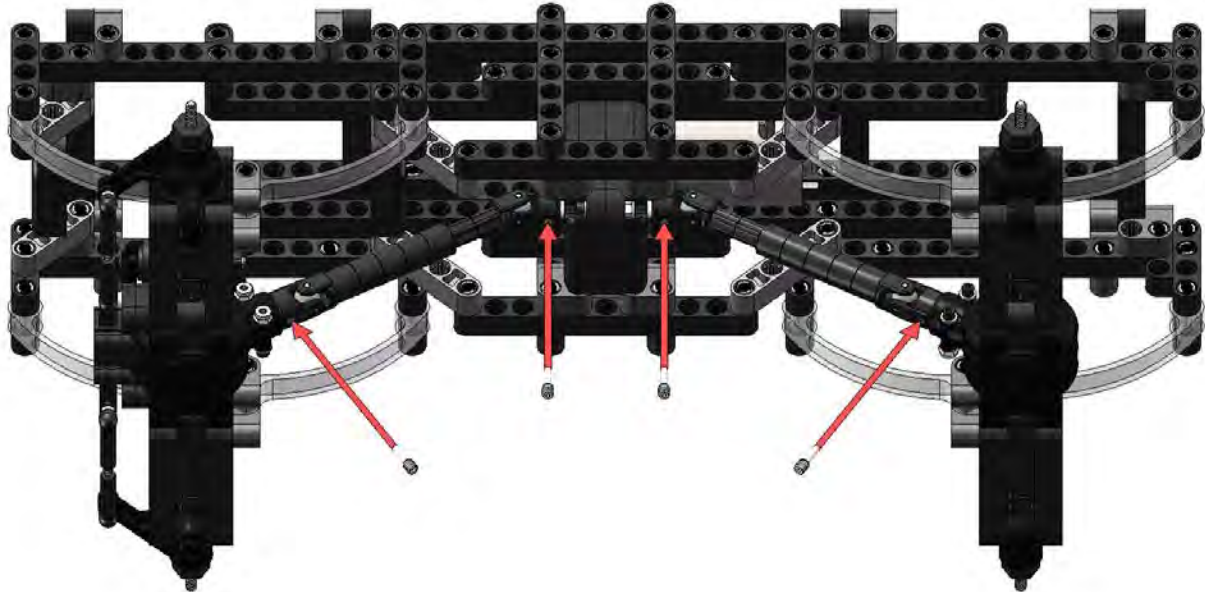

60

x4
BADLANDS 2.2" TIRE & DESPERADO WHEEL



x4
M4 WASHER



x4
M4 NUT





REFER TO RADIO TRANSMITTER MANUAL AND FOLLOWING DIAGRAMS FOR PROPER INSTALLATION AND SET-UP.

USING THE WIRE TIES AND DOUBLE-SIDED TAPE PROVIDED, PLACE THE ELECTRONIC COMPONENTS ON THE FRAME SO THAT THEY ARE SECURE AND OUT OF THE WAY OF MOVING PARTS.

BATTERY mAh _____ ÷ CHARGER mA _____ = ESTIMATED CHARGE TIME (IN HOURS)

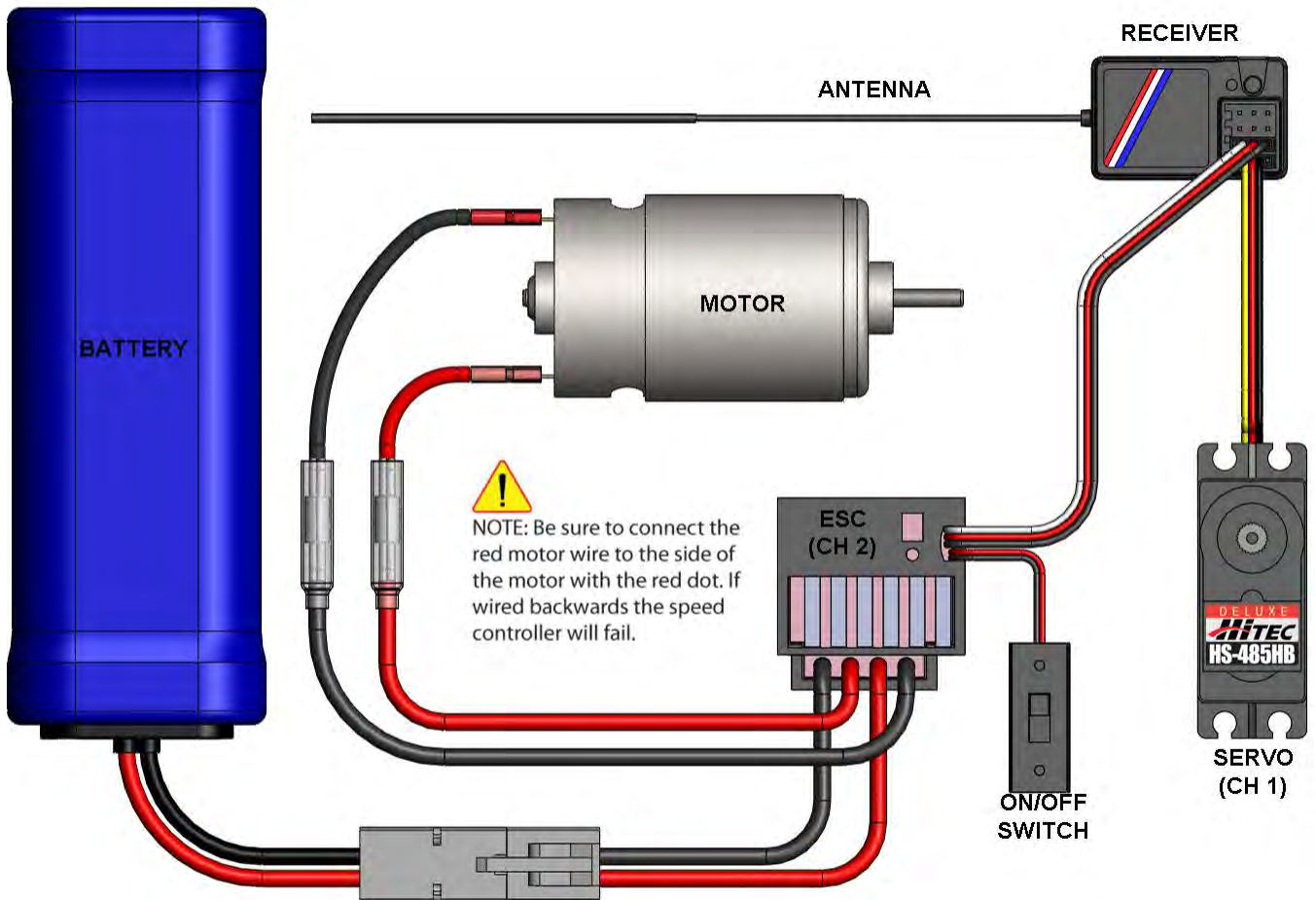

WIRE TIE

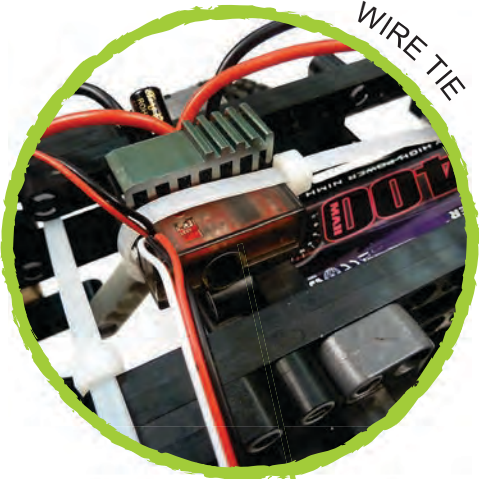

WIRE TIE + DOUBLE-SIDED TAPE

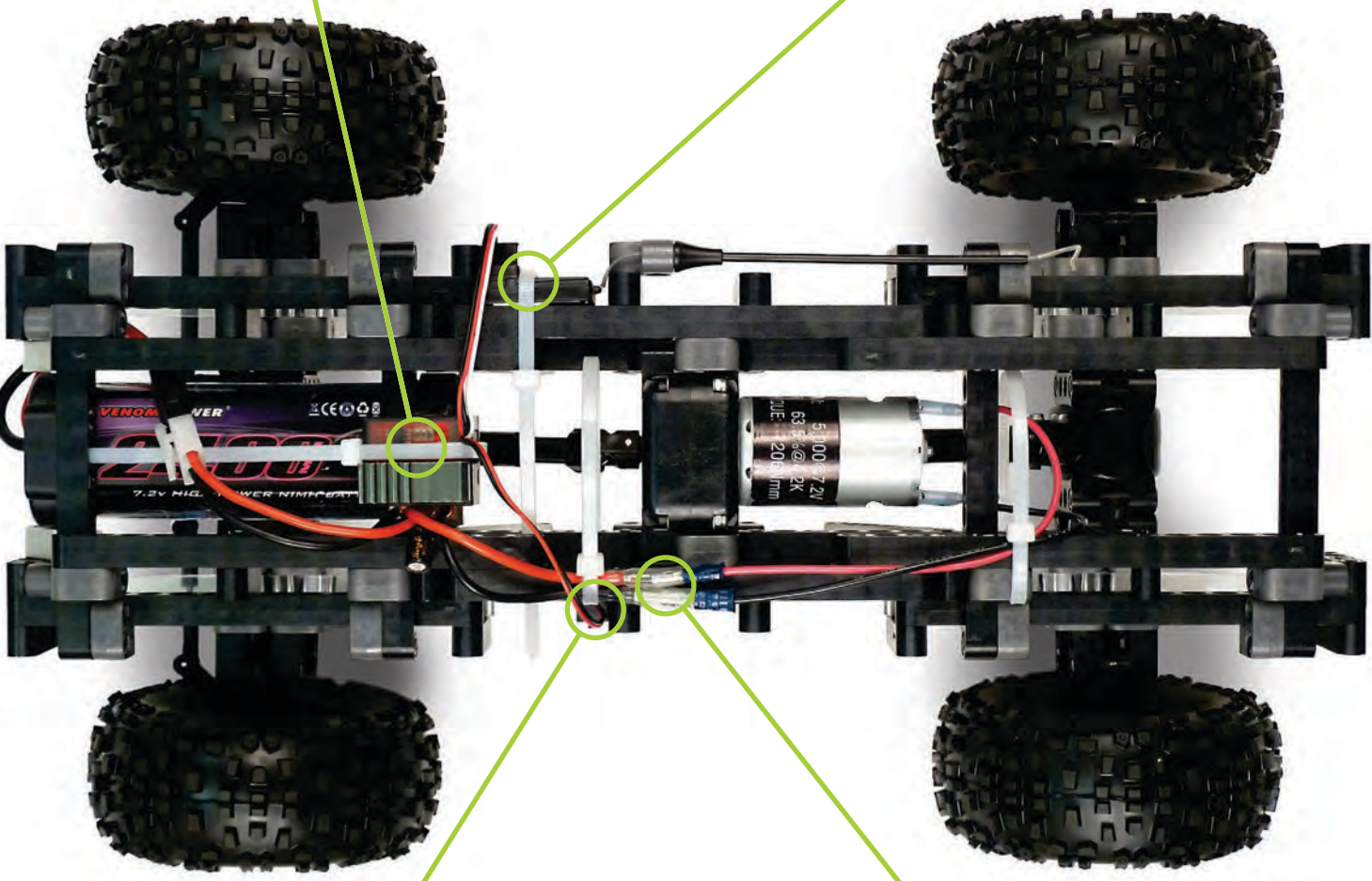
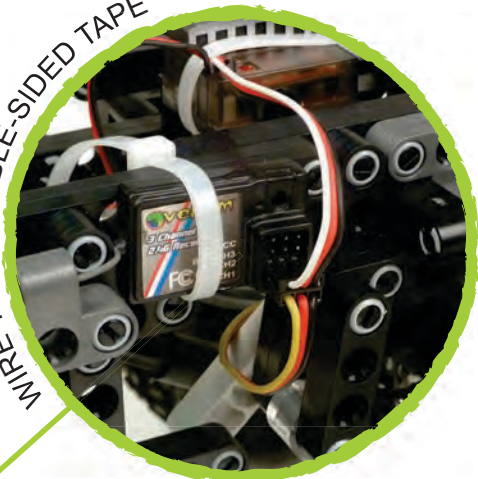

DOUBLE-SIDED TAPE

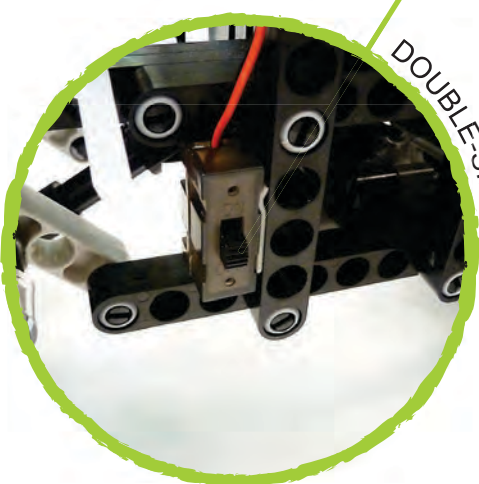

WIRE TIE

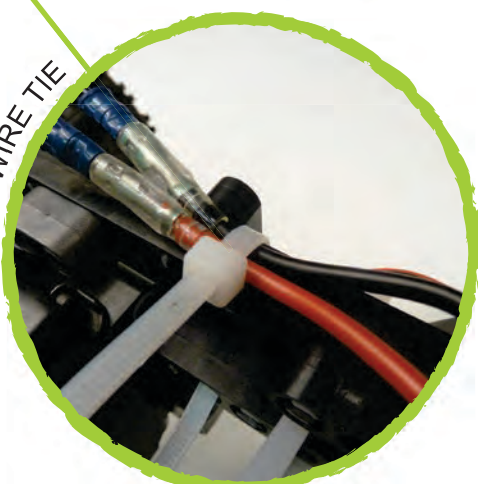

4-LINK SUSPENSION



01

x2
9-BEAM



x1
7-BEAM



x2
9-45 BEAM



x4
2-LOCK



02

x1
15-BEAM



x4
2-LOCK



x6
CLEARANCE THREAD
ADAPTER

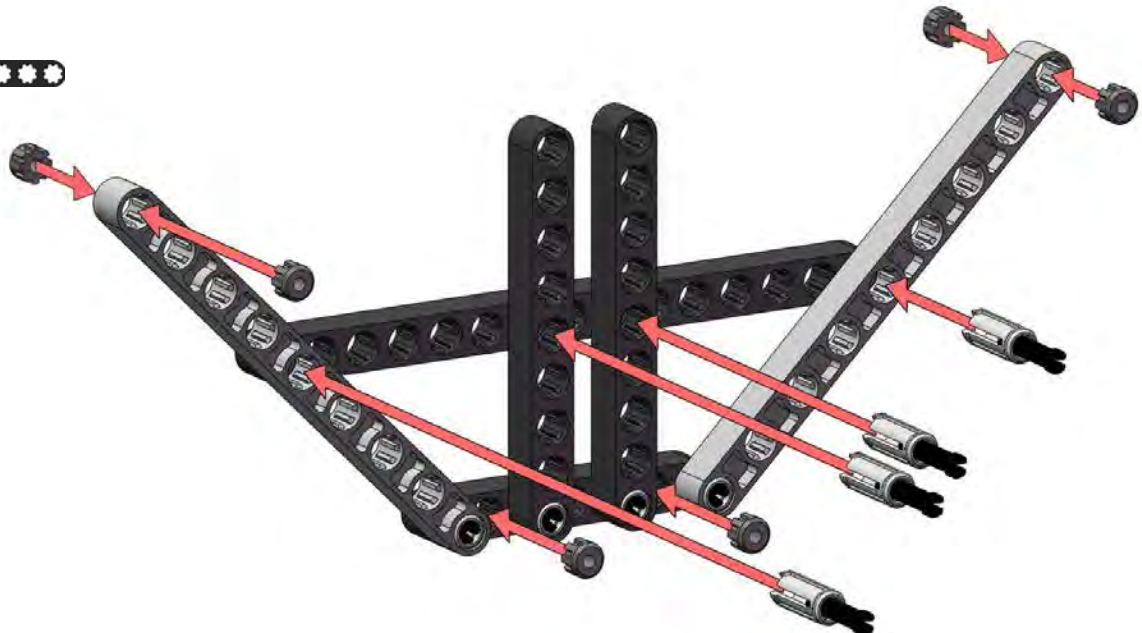



x4
CLEARANCE THREAD
ADAPTER



x2
INTERFERENCE THREAD
ADAPTER

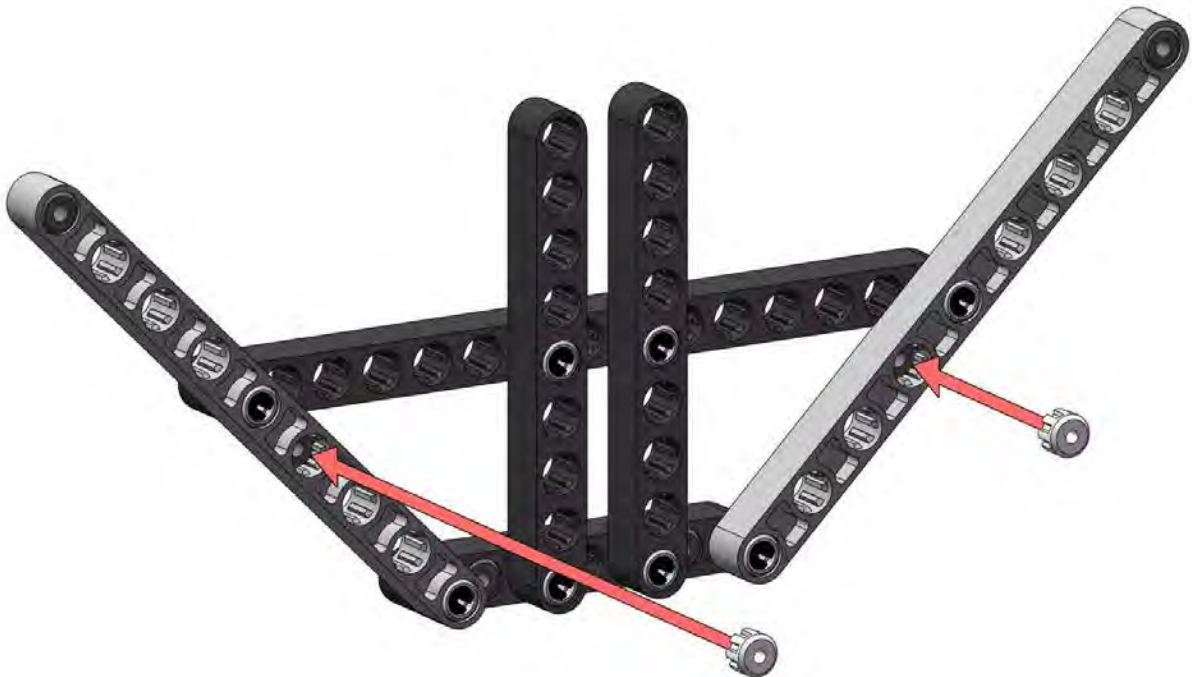

05

x2
2.4" FOUR LINK ARM

x4
ROD END



x4
ROD END BALL

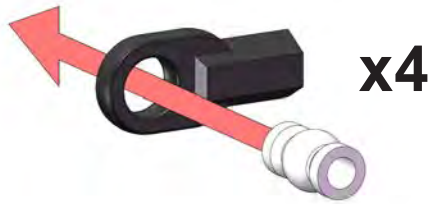

x4

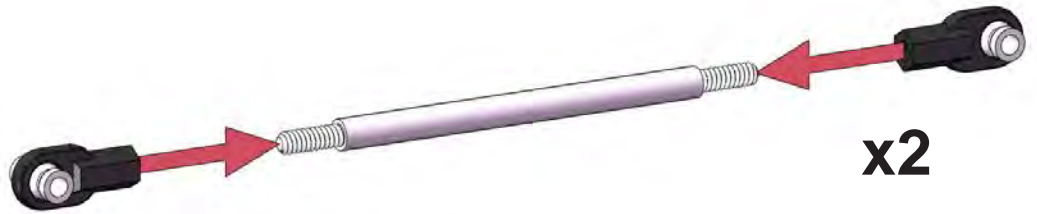

x2

06

x2
#4-40 x 1" SCREW



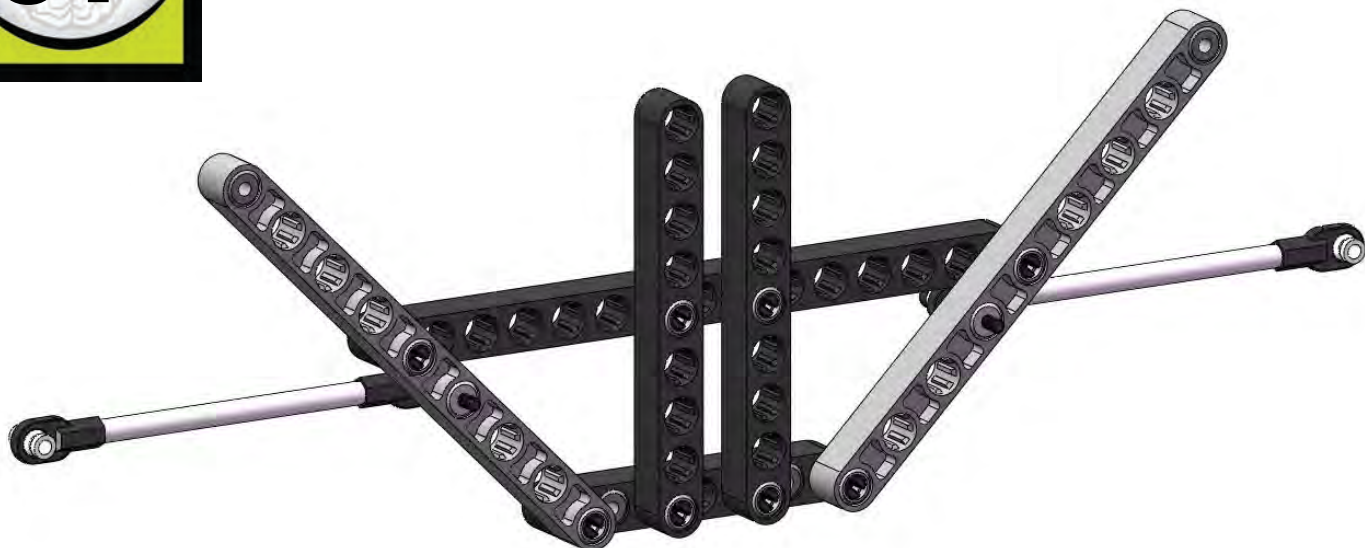

x2
REPEAT STEPS 1-6



x6
TRANSITION



x2
3-LOCK



x4
2-LOCK

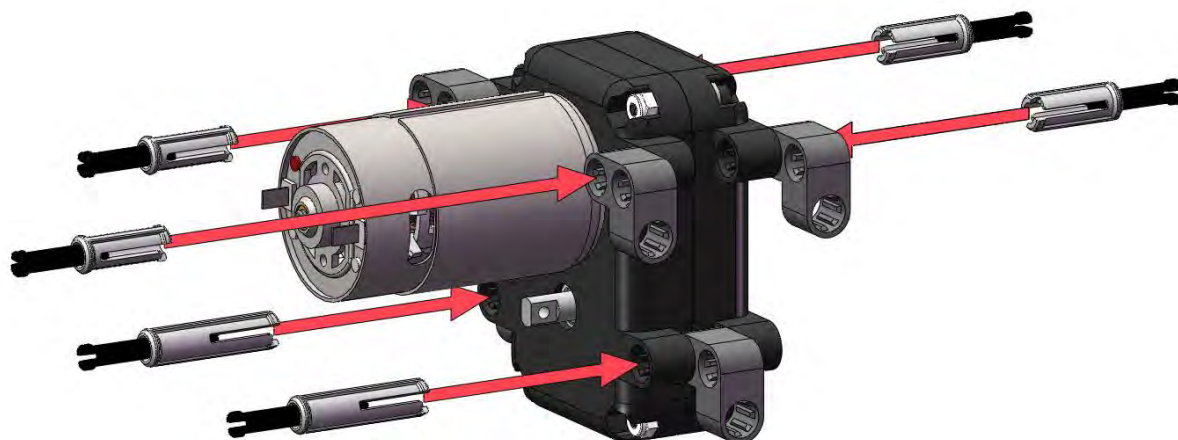



x6
2-LOCK

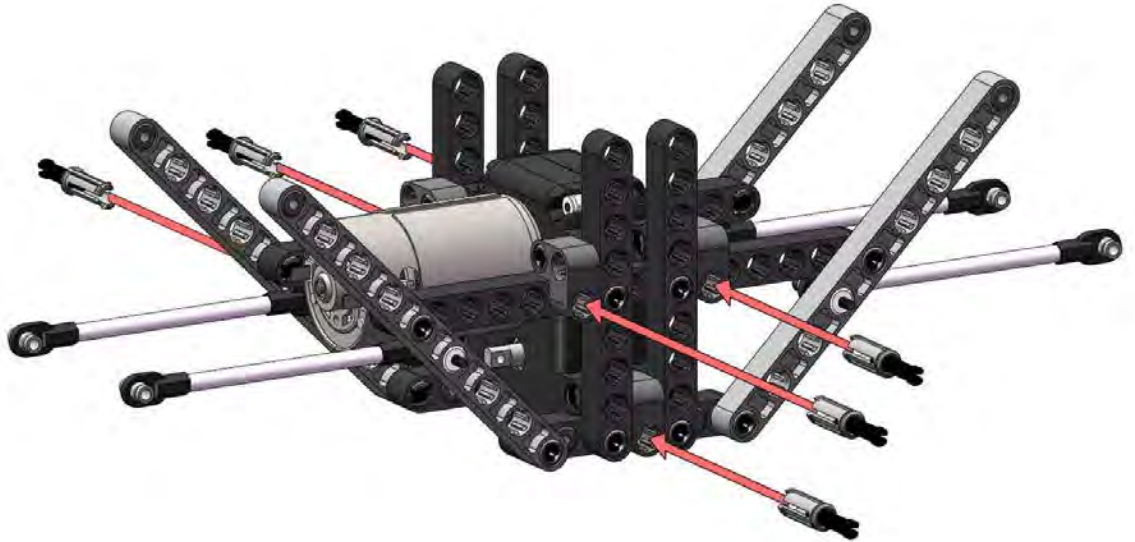

x2
BATTERY CAP



x2
9-BEAM



x4
TRANSITION



x8
2-LOCK



x2

11

x2
13-BEAM



x4
SUPPORT ARM



x8
2-LOCK



x8
CLEARANCE THREAD
ADAPTER



12

x4
2-LOCK



13

x4
2-LOCK

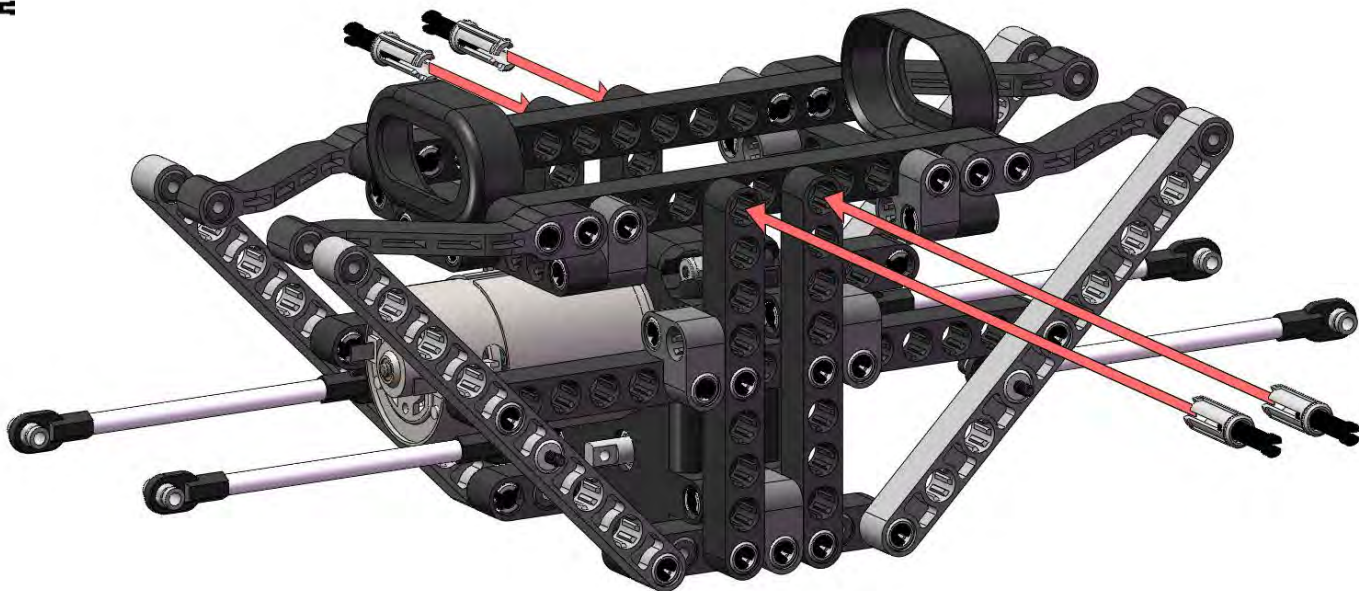

14

x4
3.6" FOUR LINK ARM

x8
ROD END

x8
ROD END BALL



x8



x4

15

x2
1.2" THREAD COLLAR

x4
#4-40 x 1" SCREW

x4
#4 WASHER

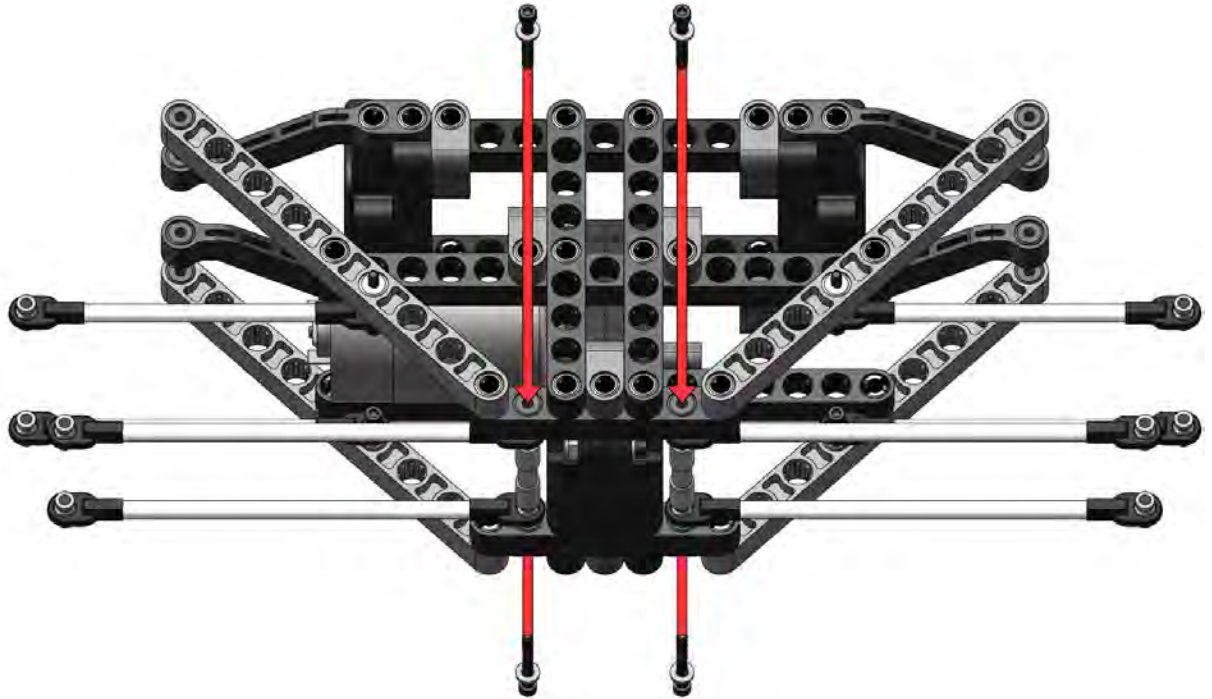

16

x4
90mm SHOCK

x2
1.2" THREAD COLLAR

x4
SHOCK MOUNT

x4
ROD END BALL

x4
#4-40 x 1-3/8" SCREW

x4
#4 WASHER



x4

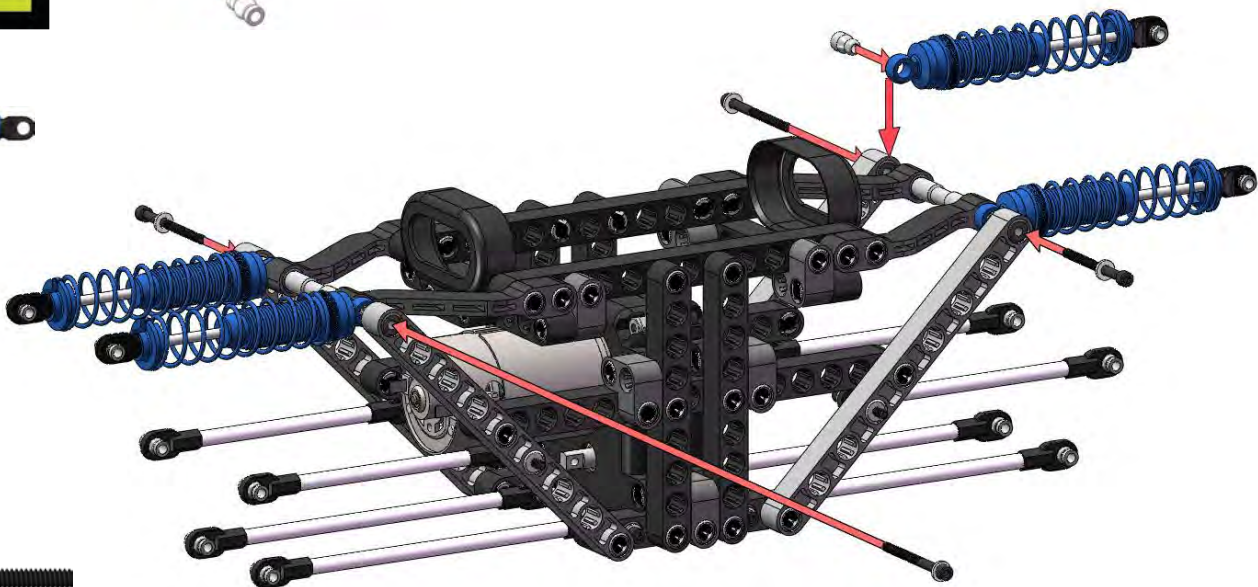

17

x4
DUAL TRANSITION

x16
CLEARANCE THREAD
ADAPTER

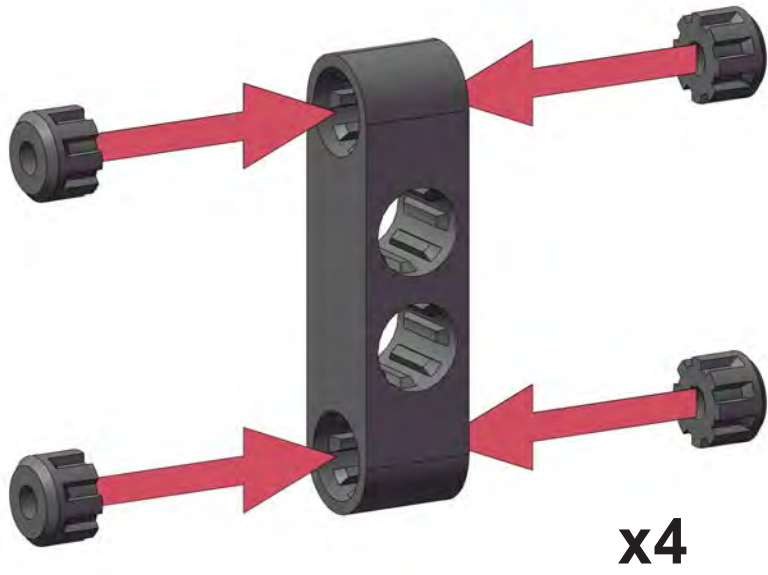

18

x2
1.2" THREAD COLLAR

x2
0.4" THREAD COLLAR

x4
#4-40 x 1-3/8" SCREW

x4
#4-40 x 1" SCREW

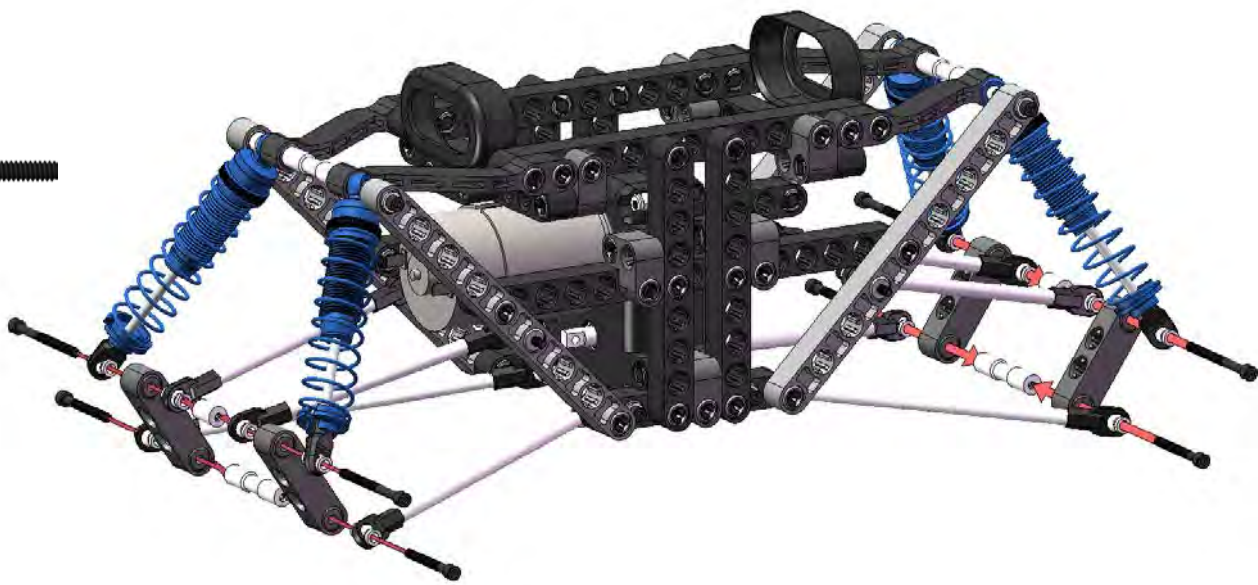

19

x2
3-DRIVELINE



x2
M4 WHEEL END SHAFT



x4
U-JOINT SET SCREW





20

x1
AXLE HOUSING

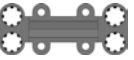

x1
STEERING BRACKET

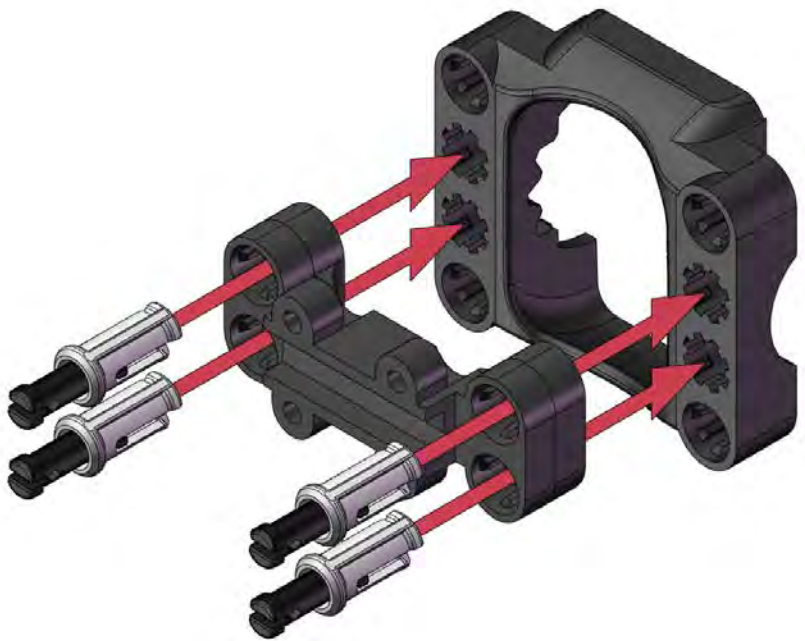

x4
1.5-LOCK

21

x1
STEERING BAR



x1
STEERING PLATE

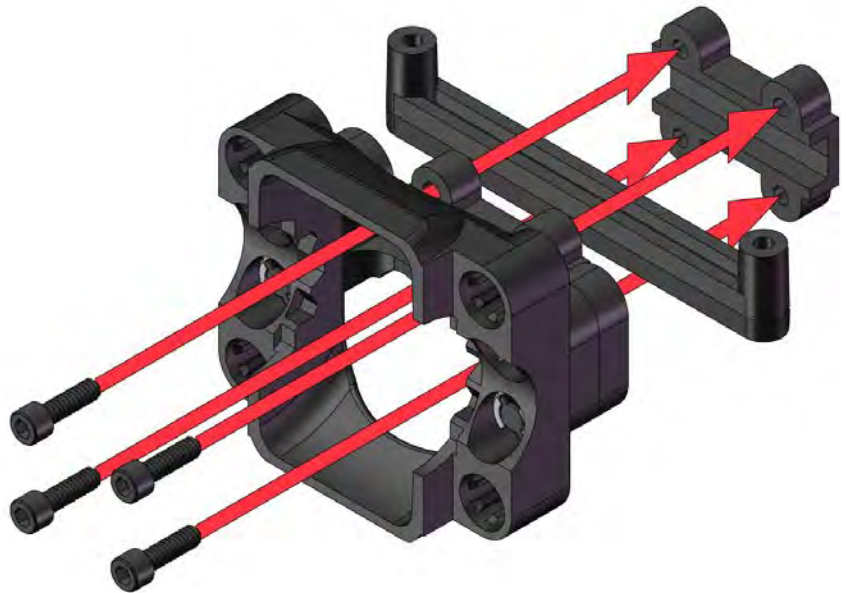

x4
#4-40 x 3/8" SCREW

22

x1
AXLE HOUSING



x2
SERVO MOUNT



x2
2-BEAM

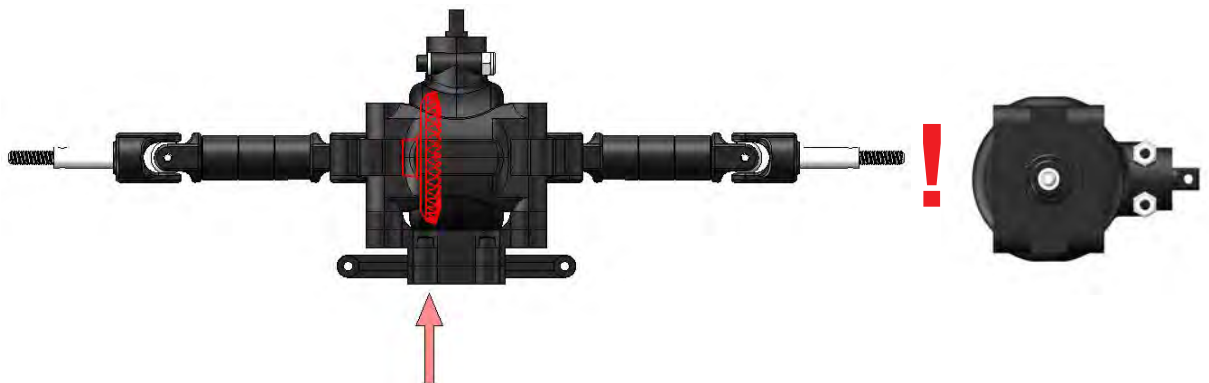

x4
3-LOCK

23

x1
HS-485HB SERVO



x4
SERVO BUSHING



x4
SERVO BUSHING SLEEVE

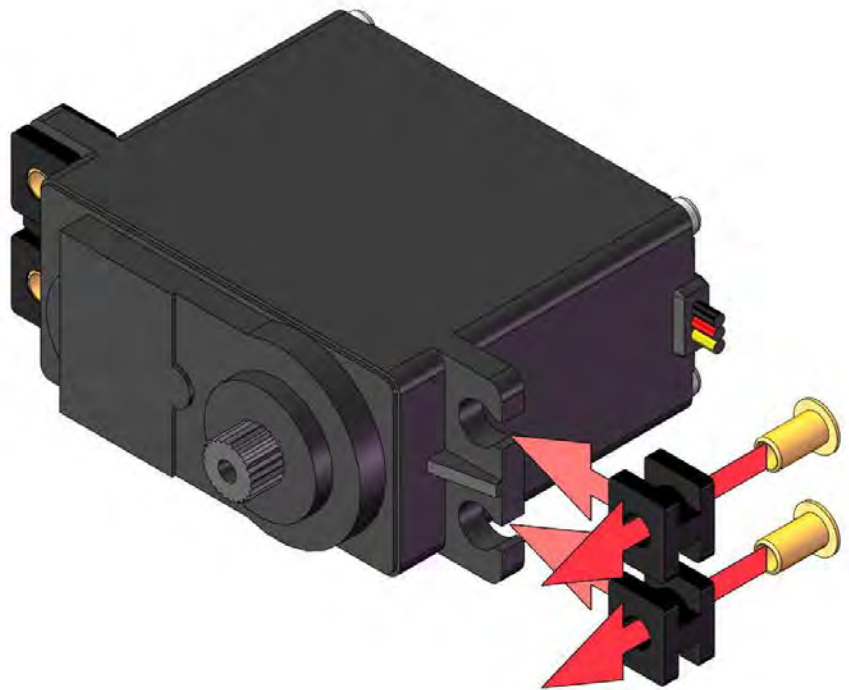



24

x4
#2-32 x 5/8" SCREW

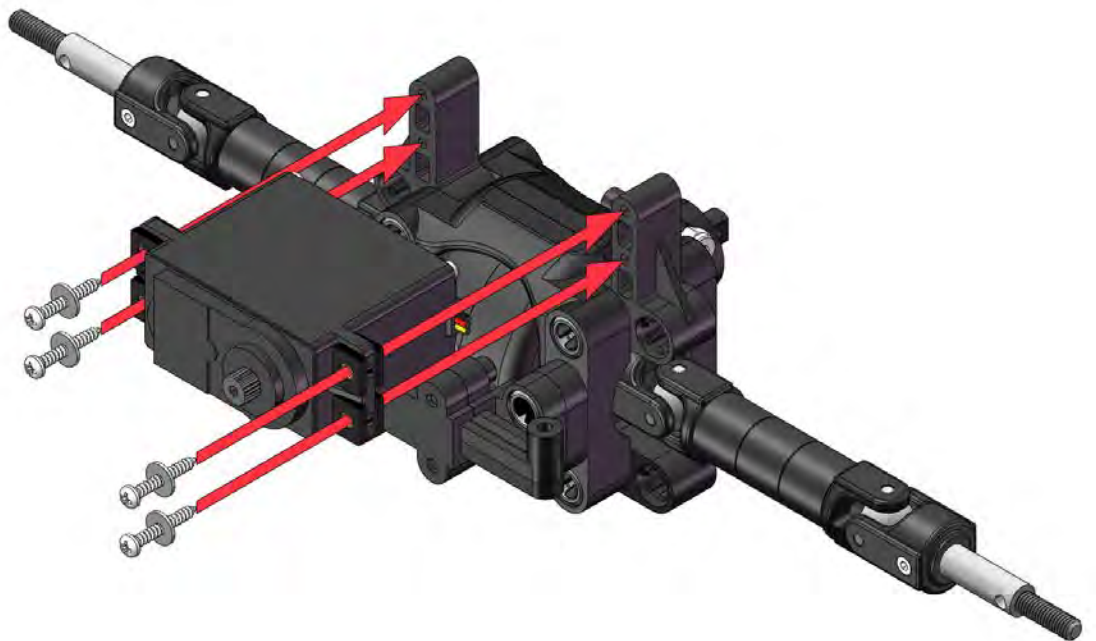

x4
#2 WASHER

25

x2
FRONT WHEEL HUB



x2
FRONT WHEEL KNUCKLE



x8
6-BEAM



x4
3-LOCK



x4
6x12x4mm BEARING

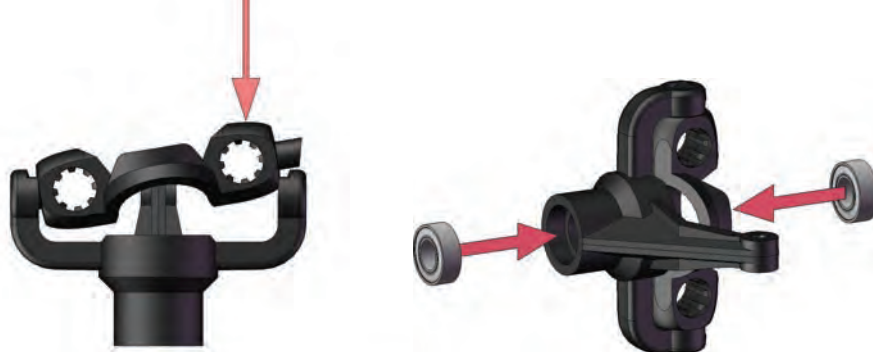

x2

26

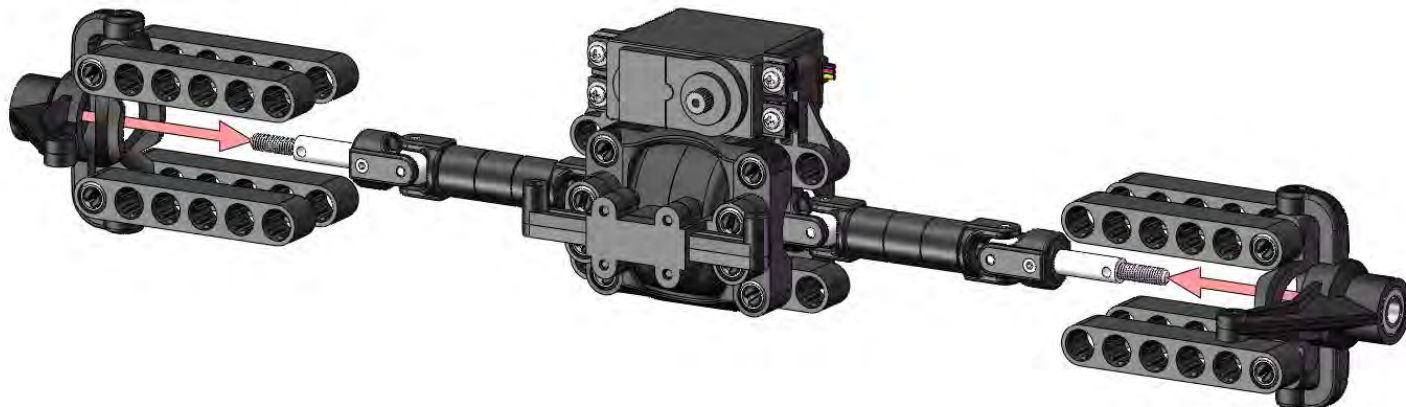



x4
3-LOCK

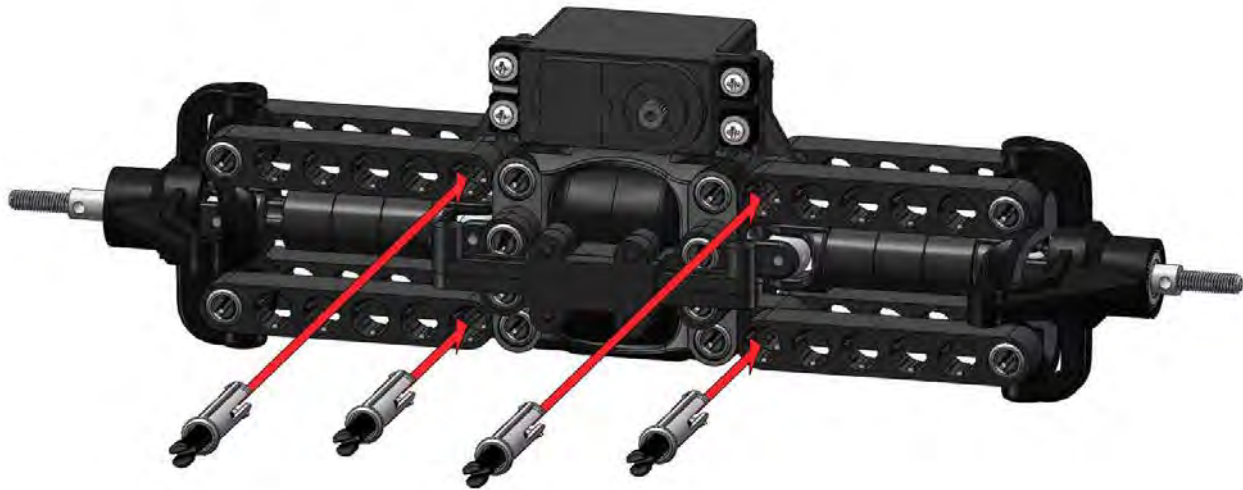

x5
3/16" BALL STUD

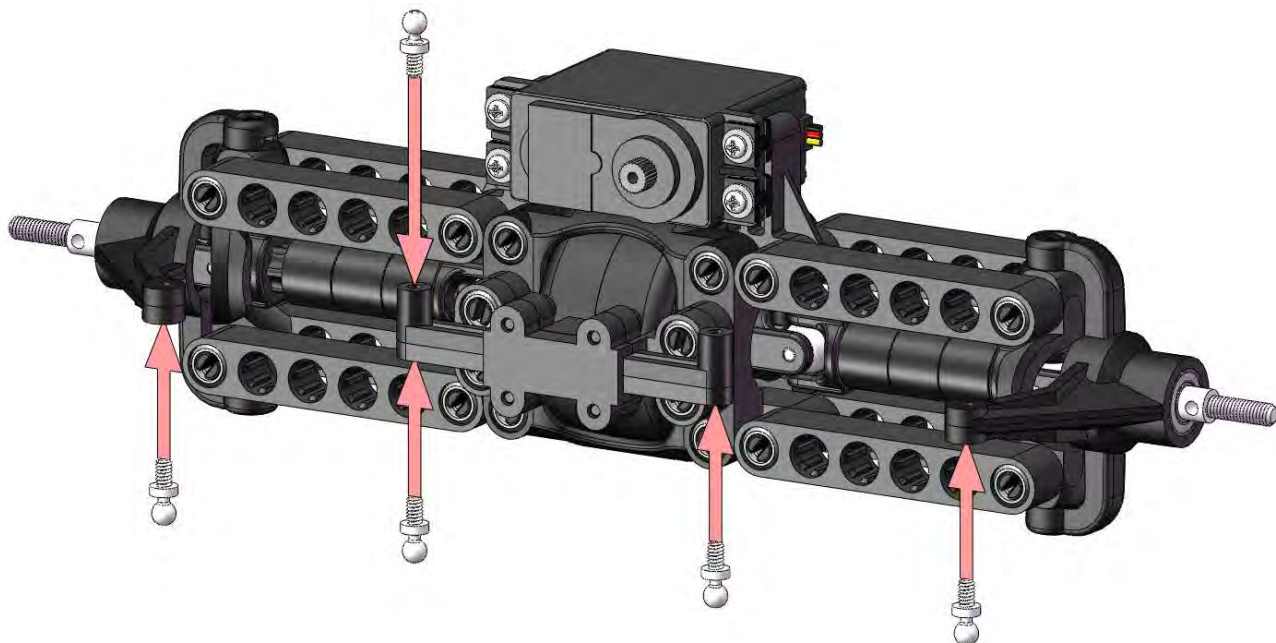



x2
#4-40 x 1-1/2" THREAD ROD



x4
23mm BALL CUP



=

1:1 SCALE



x2

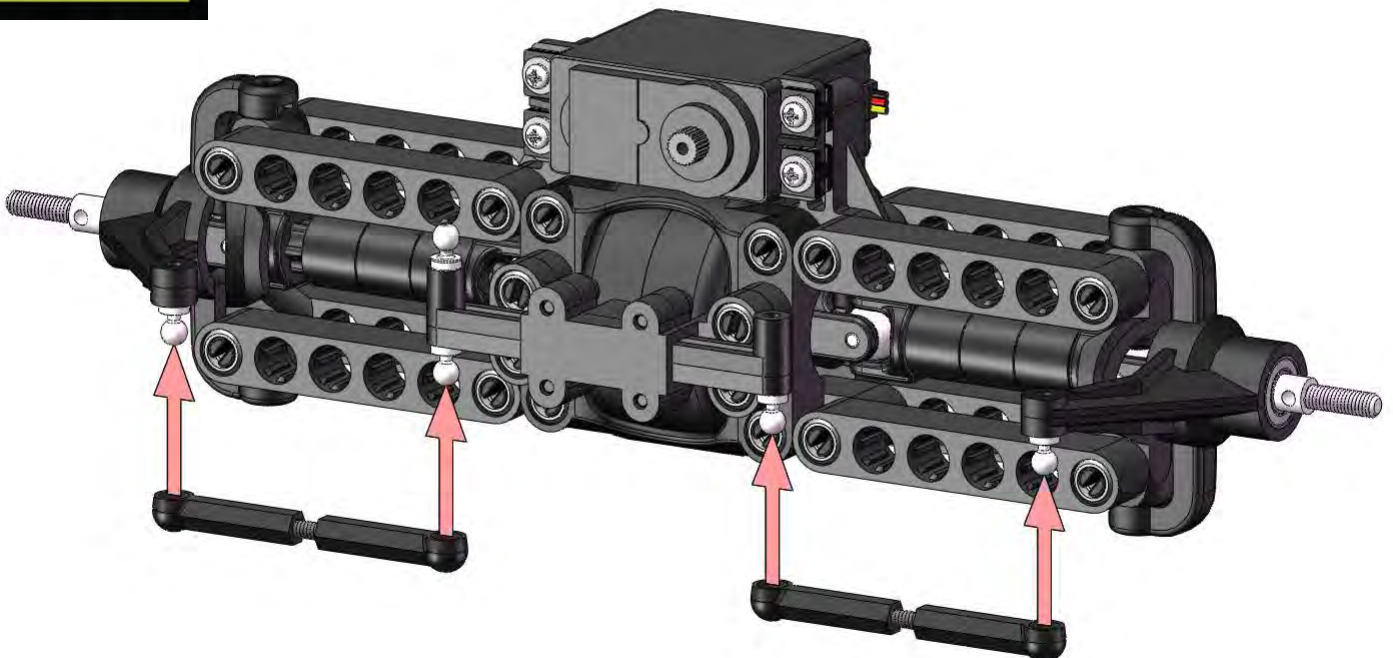



x1
#4-40 x 1" THREAD ROD

x2
18mm BALL CUP



=

1:1 SCALE



x1
STEERING SERVO HORN

x1
3/16" BALL STUD



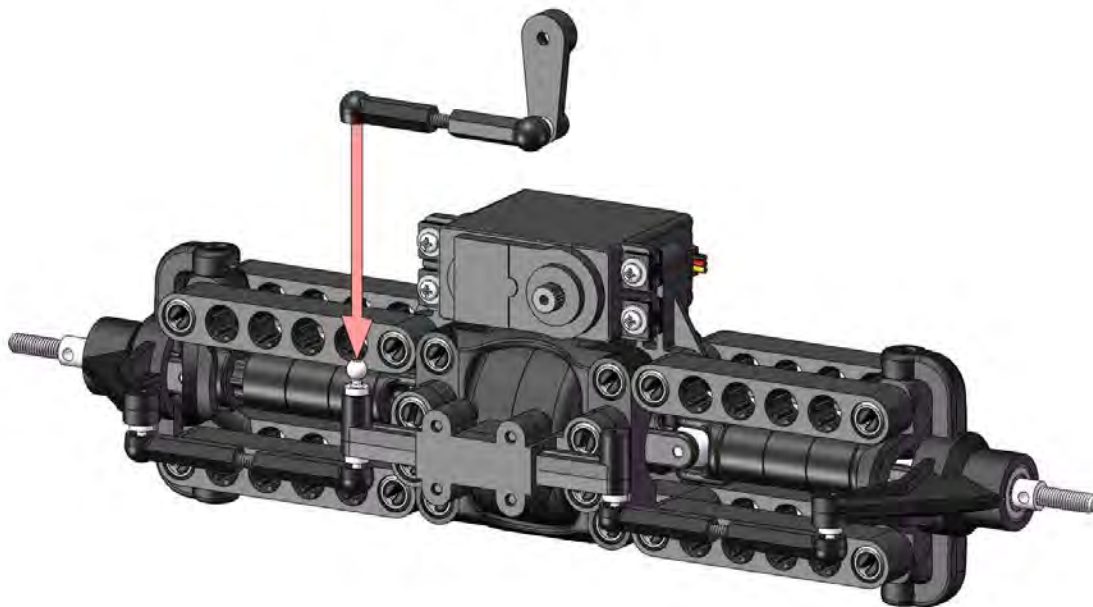

NOTE: REFER TO RADIO CONTROL SYSTEM INSTRUCTION MANUAL FOR PROPER SERVO SET-UP AND ADJUSTMENT



x1
SERVO HORN SCREW

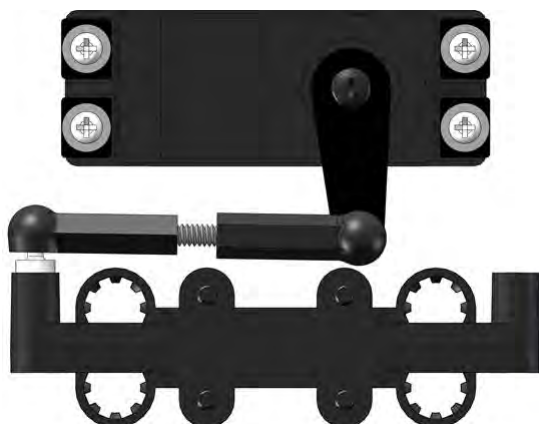
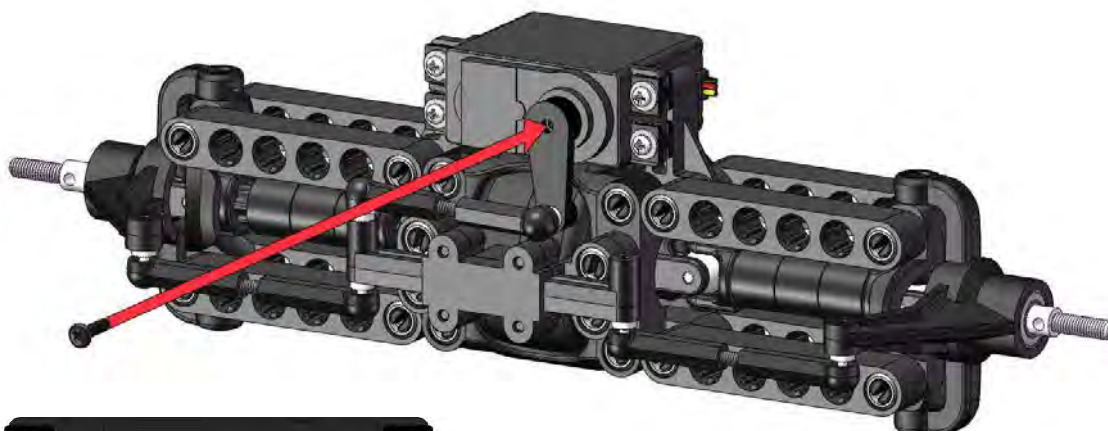



x2
12mm WHEEL NUT



x2
2.5x10mm DOWEL PIN

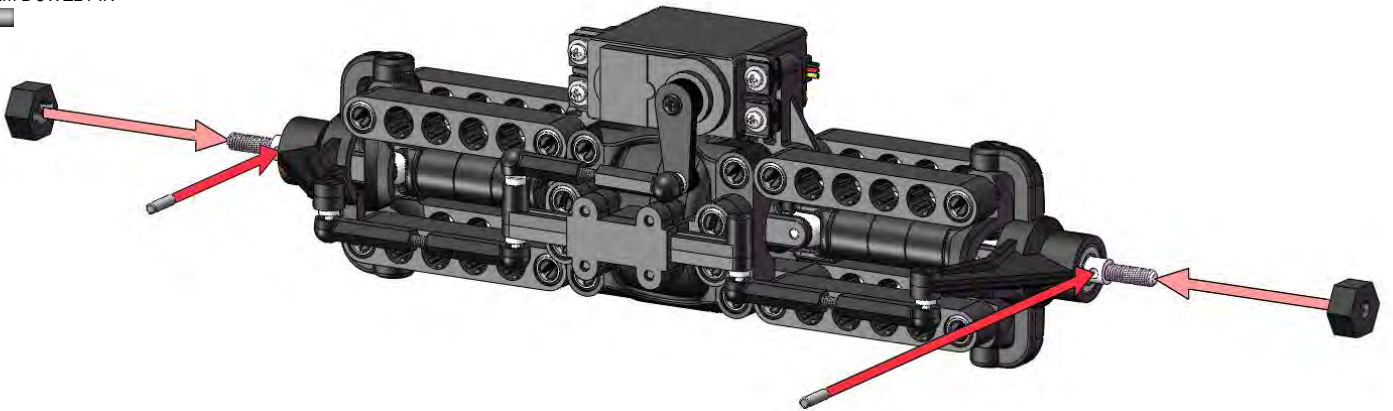

x2
3-DRIVELINE



x2
M4 WHEEL END SHAFT



x4
U-JOINT SET SCREW

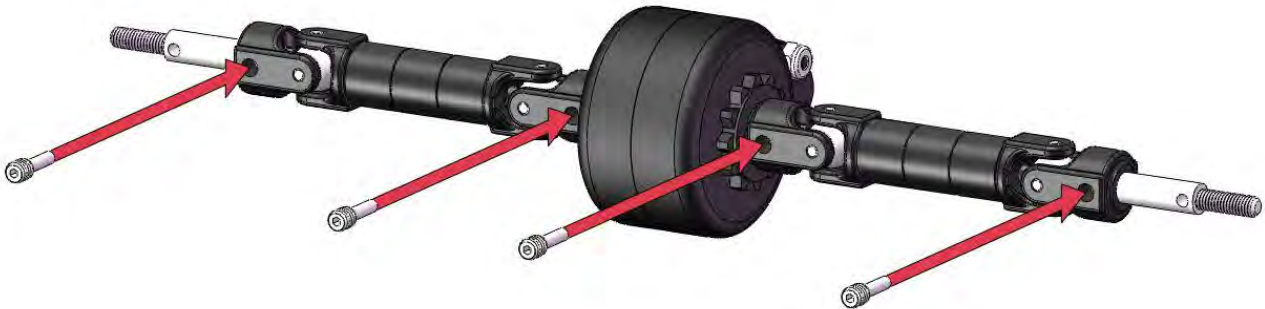

37

x2
AXLE HOUSING



x4
2-BEAM



x4
3-LOCK

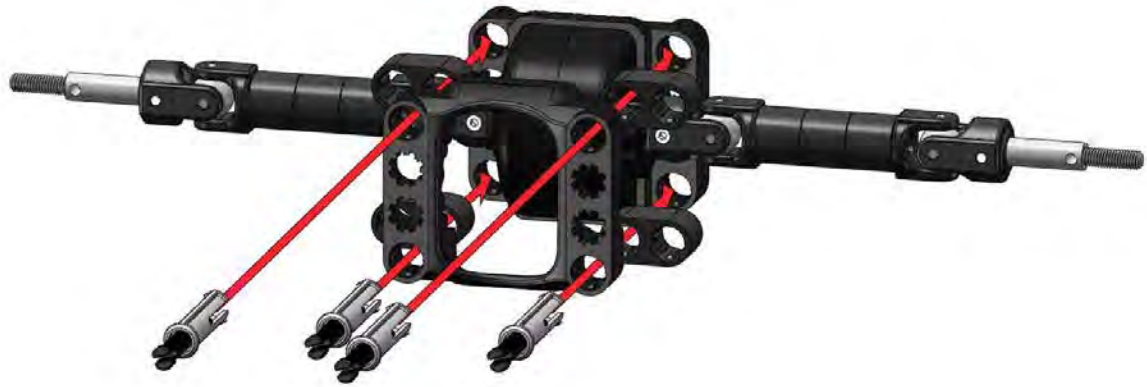

38

x2
REAR WHEEL HUB



x8
6-BEAM



x4
3-LOCK



x4
6x12x4mm BEARING





x4
3-LOCK



41

x2
12mm WHEEL NUT



x2
2.5x10mm DOWEL PIN



42

x8
1.5-LOCK

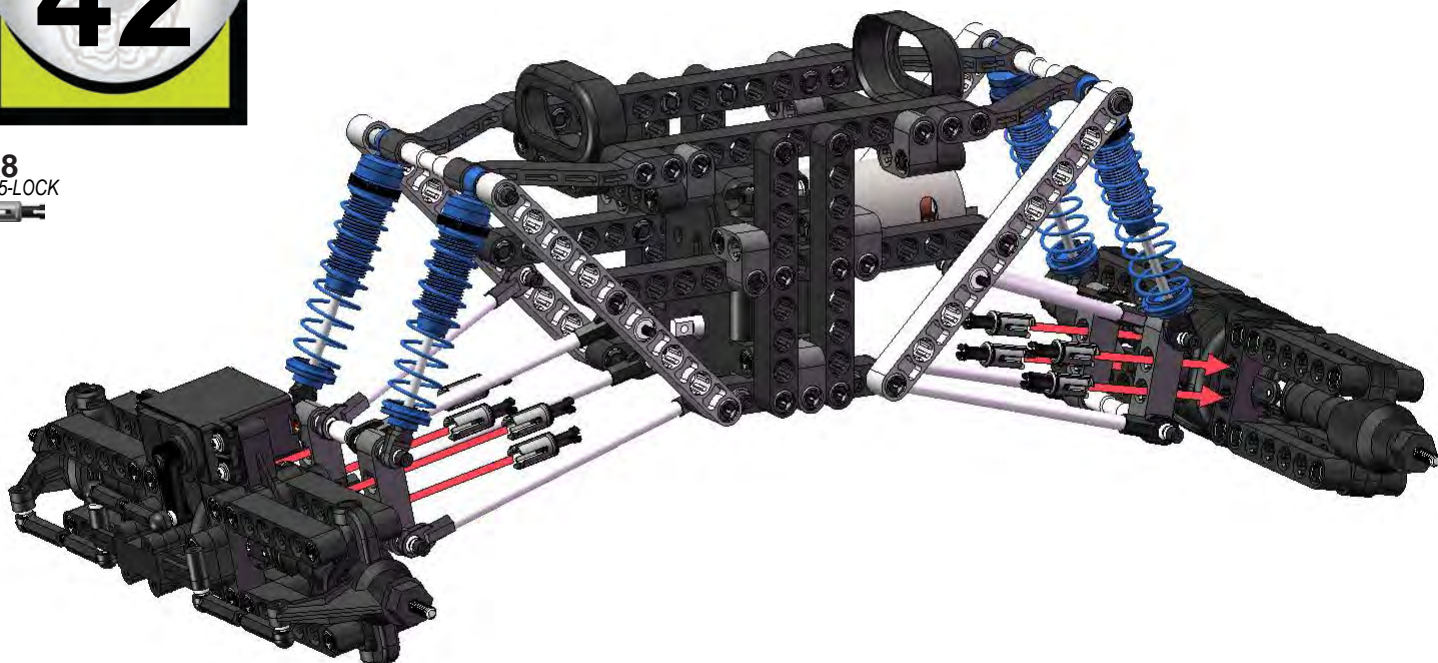

43

x2
5-DRIVELINE



x4
U-JOINT SET SCREW

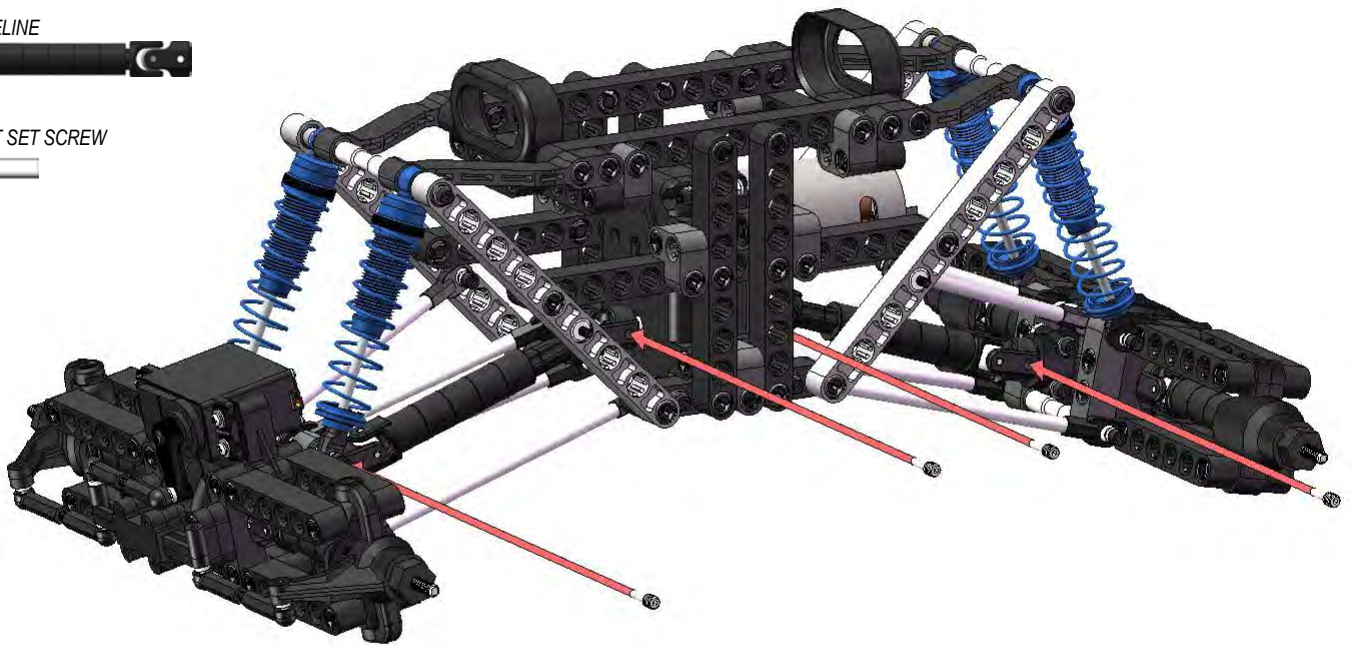

44

x1
13-BEAM



x4
7-BEAM



x2
6-45 BEAM



x2
TRANSITION



x4
3-LOCK



x2
2-LOCK

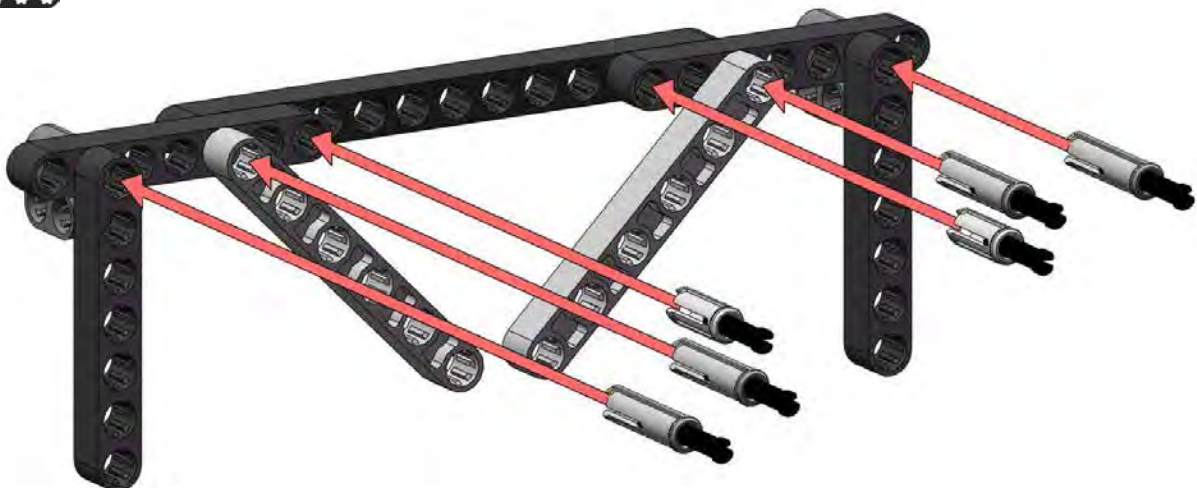



x2



x2
7-BEAM



x4
2-LOCK



47

x8
2-LOCK

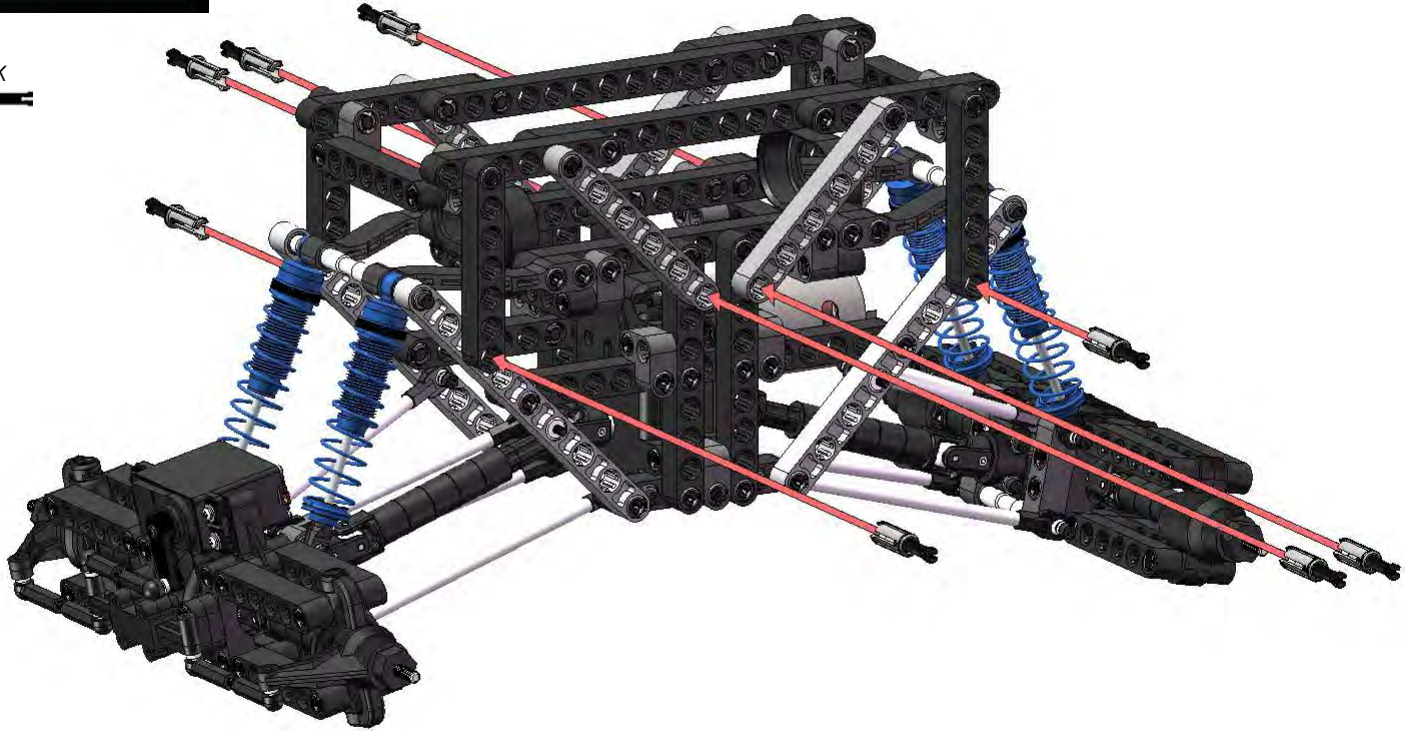

48

x4
BADLANDS 2.2" TIRE & DESPERADO WHEEL



x4
M4 WASHER



x4
M4 NUT

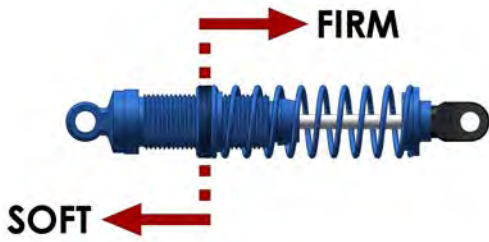



REFER TO RADIO TRANSMITTER MANUAL AND FOLLOWING DIAGRAMS FOR PROPER INSTALLATION AND SET-UP.

USING THE WIRE TIES AND DOUBLE-SIDED TAPE PROVIDED, PLACE THE ELECTRONIC COMPONENTS ON THE FRAME SO THAT THEY ARE SECURE AND OUT OF THE WAY OF MOVING PARTS.

BATTERY mAh _____ ÷ CHARGER mA _____ = ESTIMATED CHARGE TIME (IN HOURS)

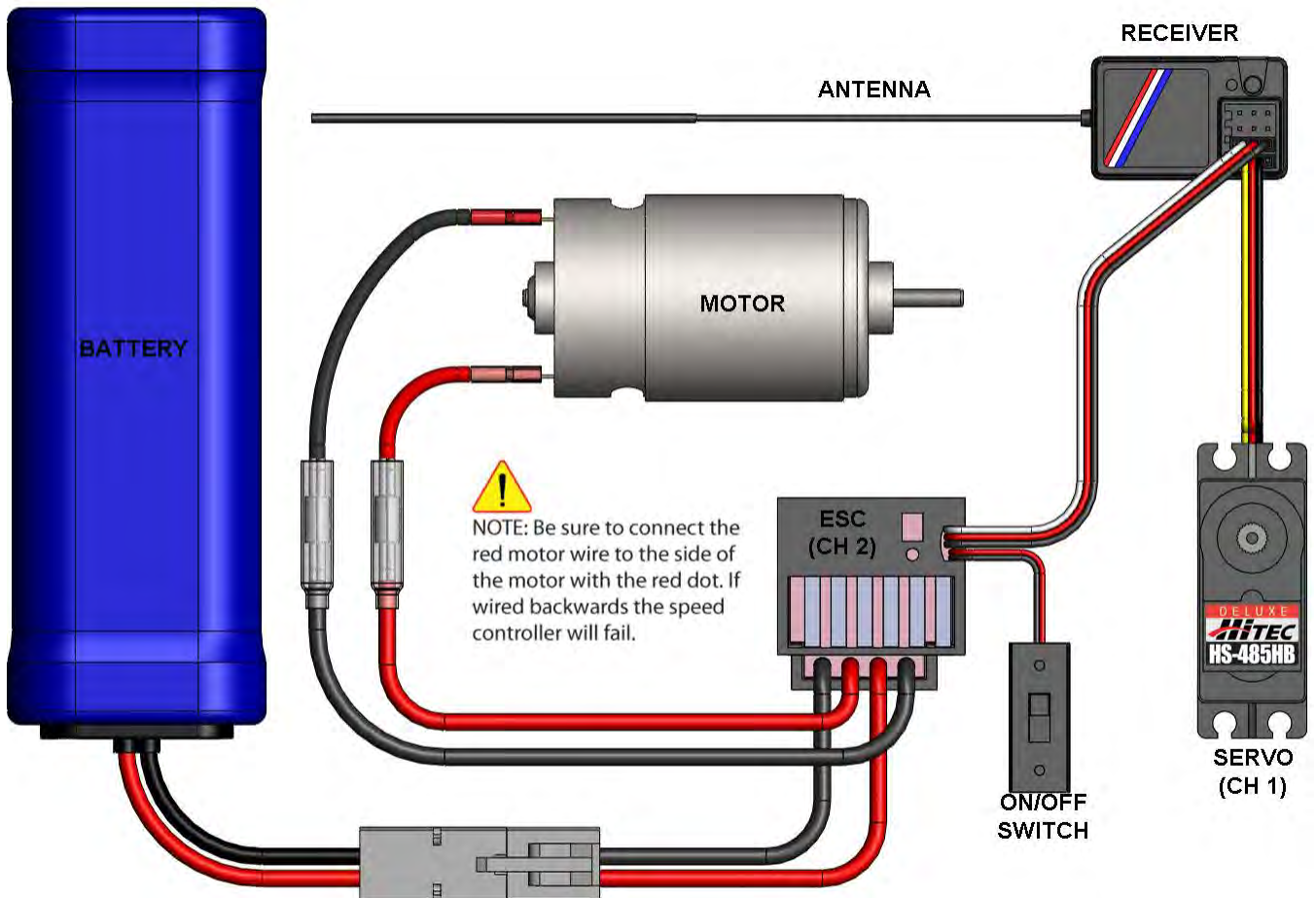

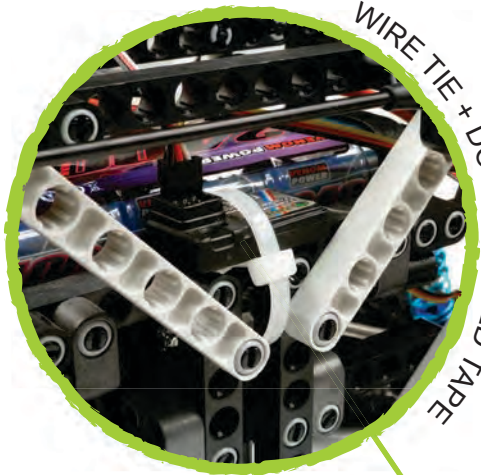

WIRE TIE + DOUBLE-SIDED TAPE

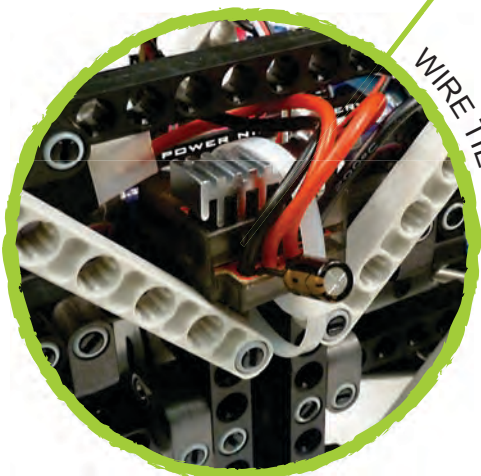
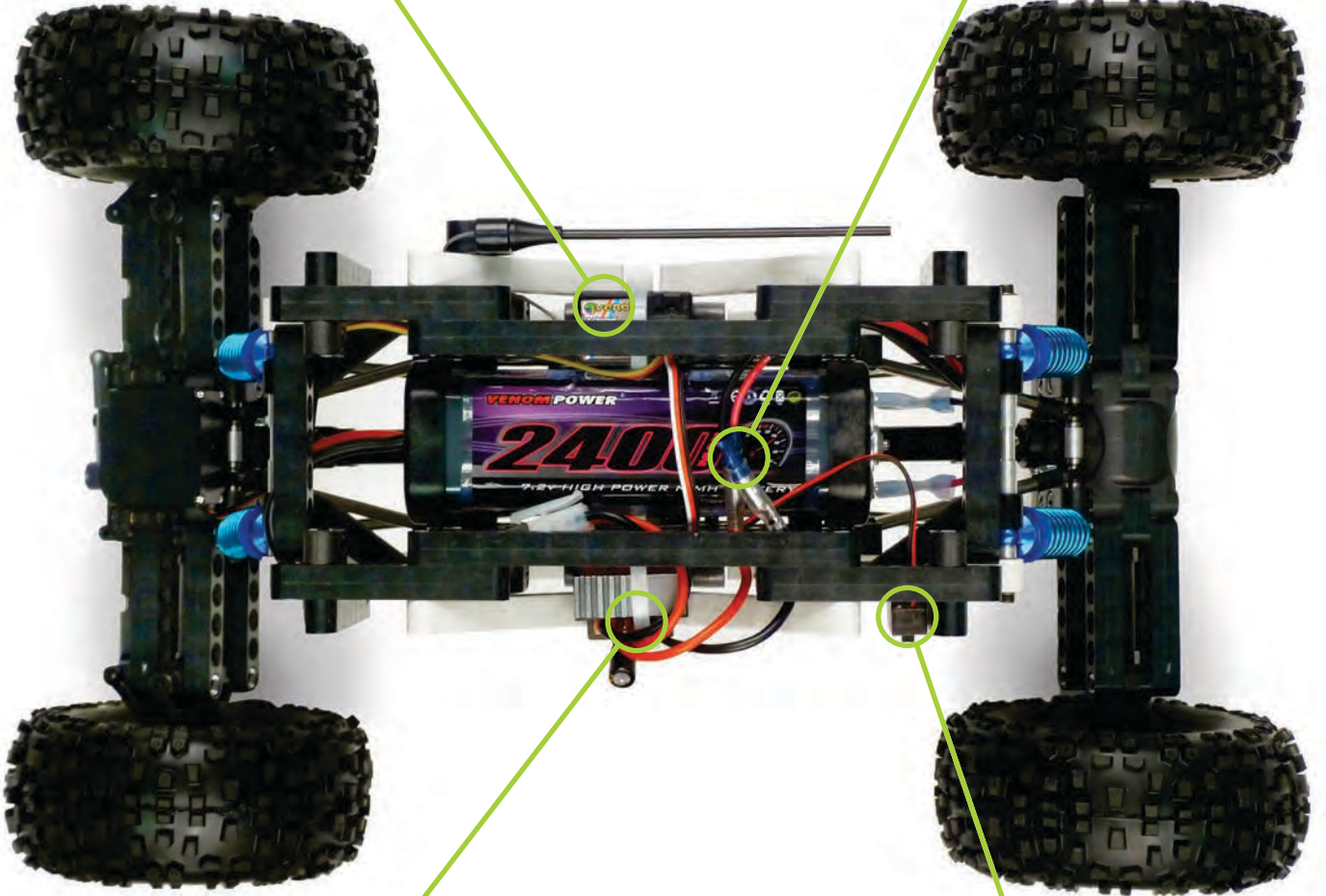

WIRE TIE

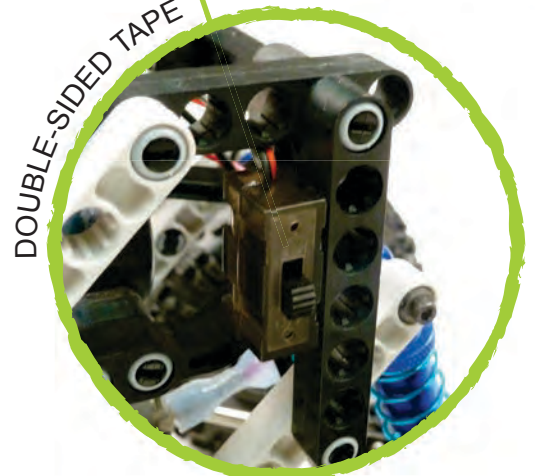

DOUBLE-SIDED TAPE

LADDER BAR SUSPENSION





x1
11-BEAM



x1
10-BEAM



x1
8-BEAM



x1
6-BEAM



x4
2-LOCK

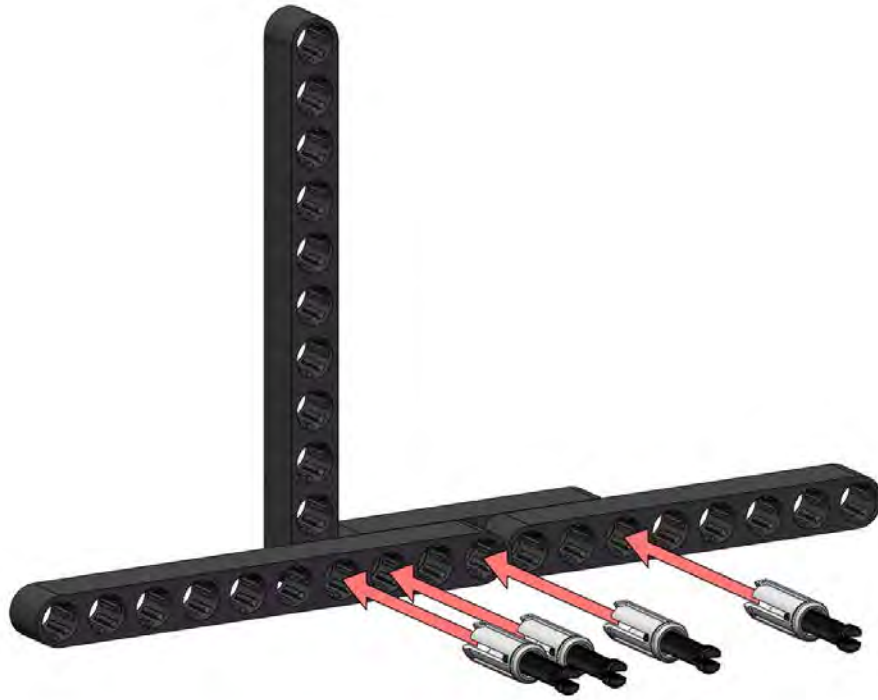

x1
6-BEAM



x1
5-BEAM



x1
DUAL TRANSITION



x1
3-ROTATE



x2
2-ROTATE



03

x1
13-BEAM



x1
2-LOCK

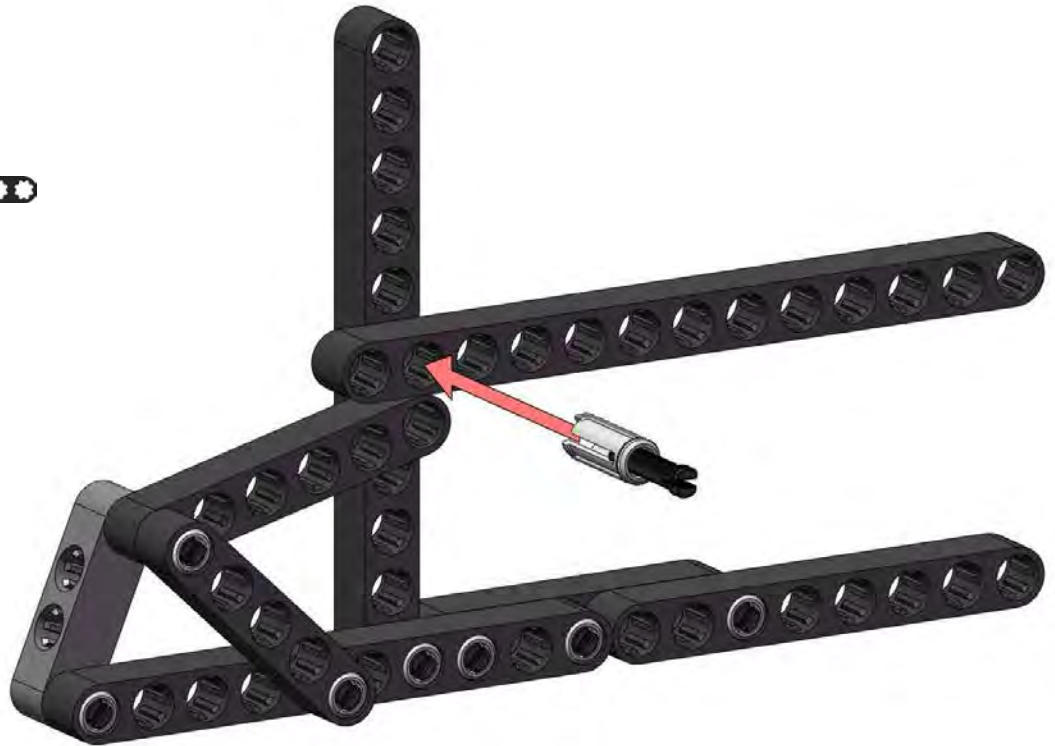



04

x3
CLEARANCE THREAD
ADAPTER

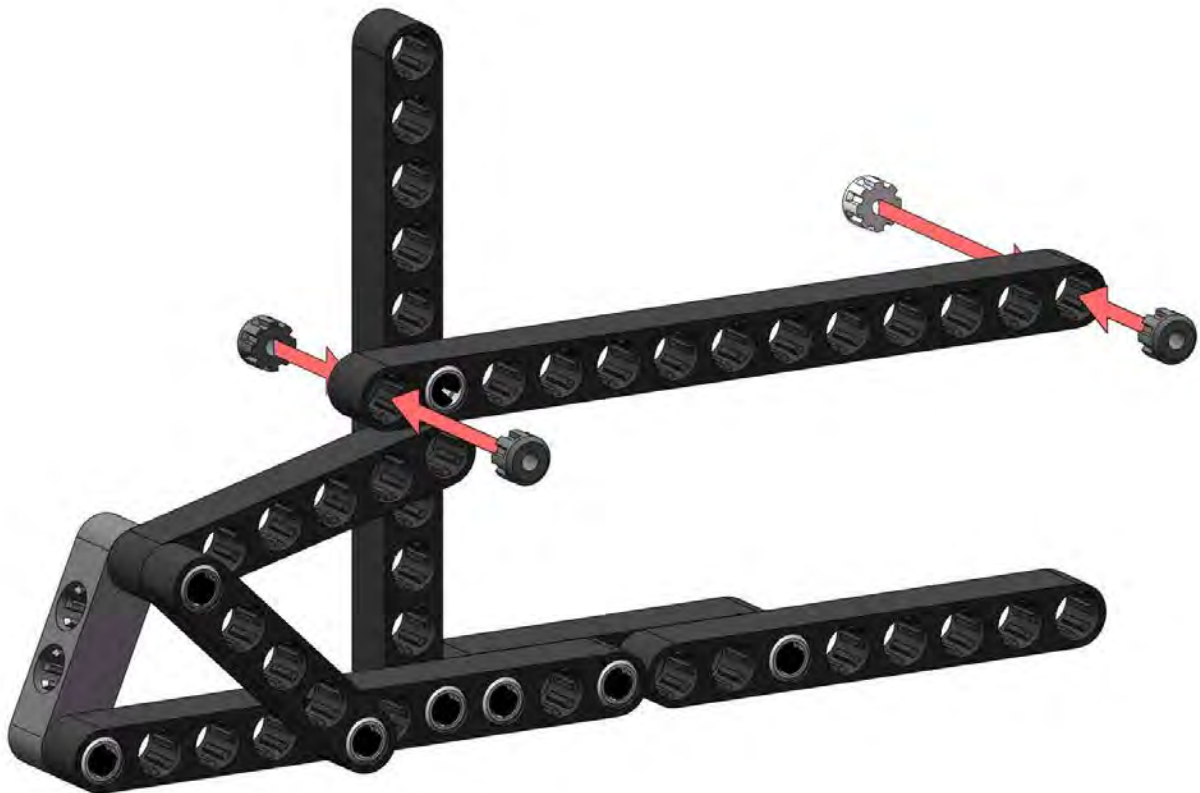

x1
INTERFERENCE THREAD
ADAPTER



05

x1
11-BEAM



x1
6-45 BEAM



x1
3-LOCK



x1
3-ROTATE



x1
2-LOCK



x2
CLEARANCE THREAD
ADAPTER



06

x1
11-BEAM



x1
10-BEAM



x1
8-BEAM



x1
6-BEAM



x4
2-LOCK

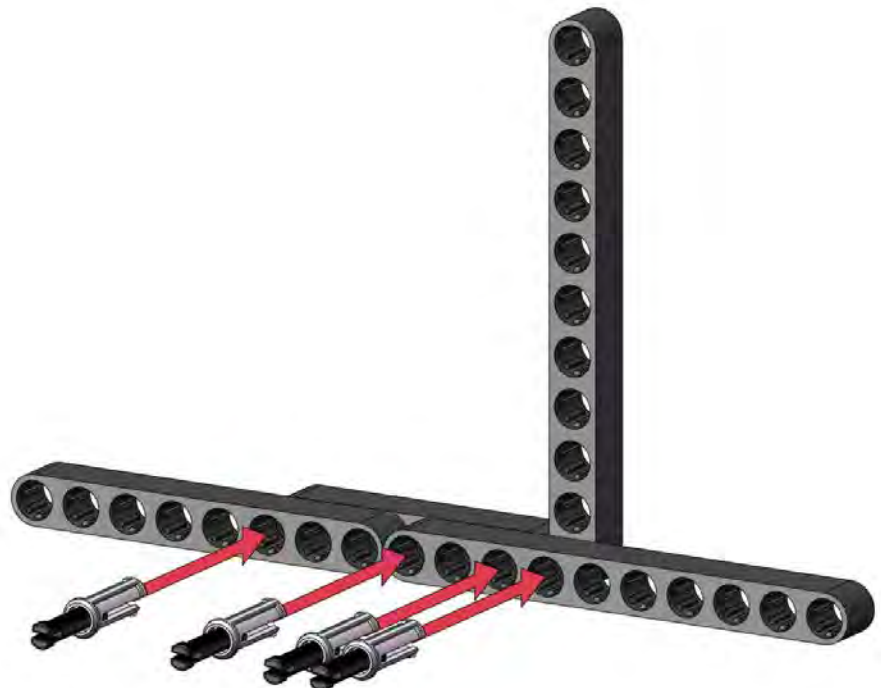

x1
6-BEAM



x1
5-BEAM



x1
DUAL TRANSITION



x1
3-ROTATE



x2
2-ROTATE

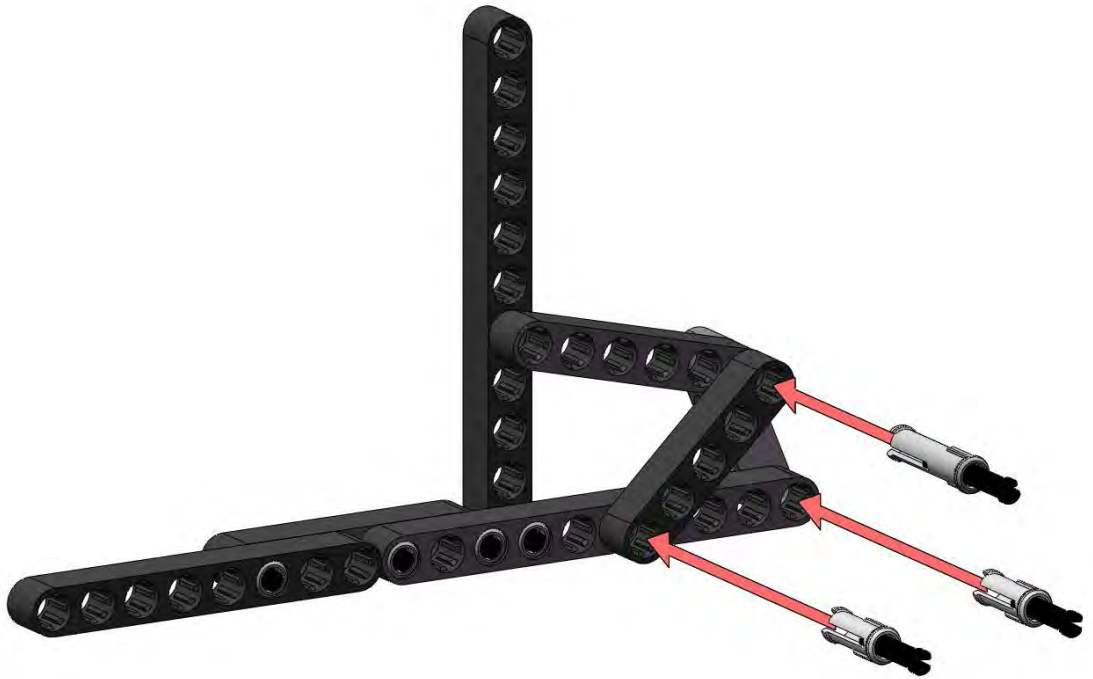

x1
13-BEAM



x1
2-LOCK



09

x3
CLEARANCE THREAD
ADAPTER



x1
INTERFERENCE THREAD
ADAPTER

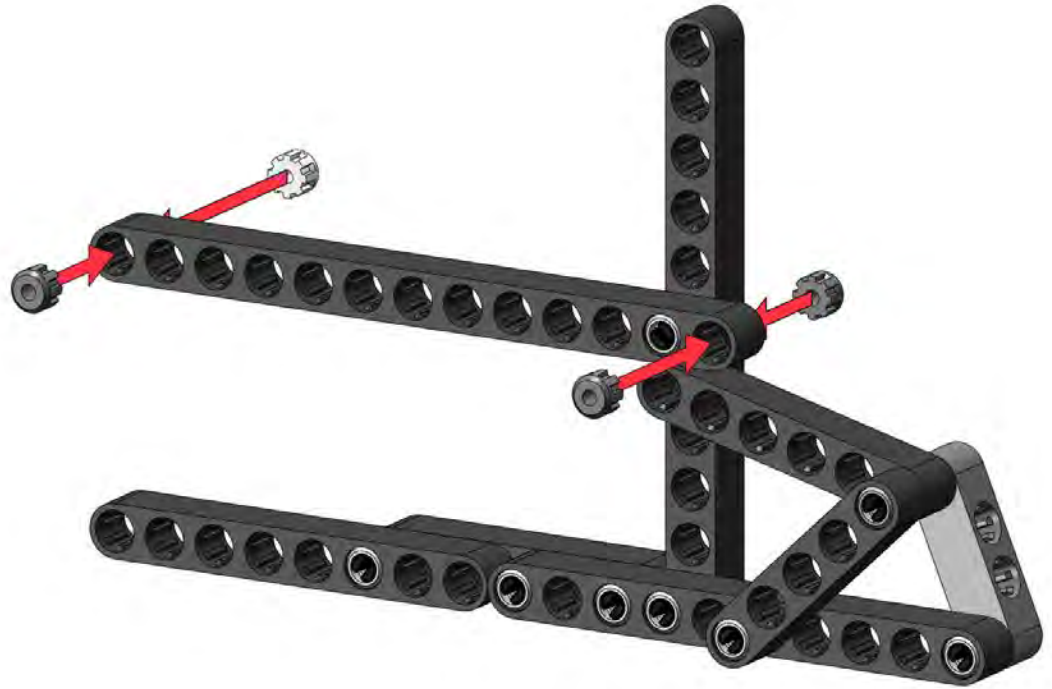

10

x1
11-BEAM



x1
6-45 BEAM



x1
3-LOCK



x1
3-ROTATE



x1
2-LOCK



x2
CLEARANCE THREAD
ADAPTER

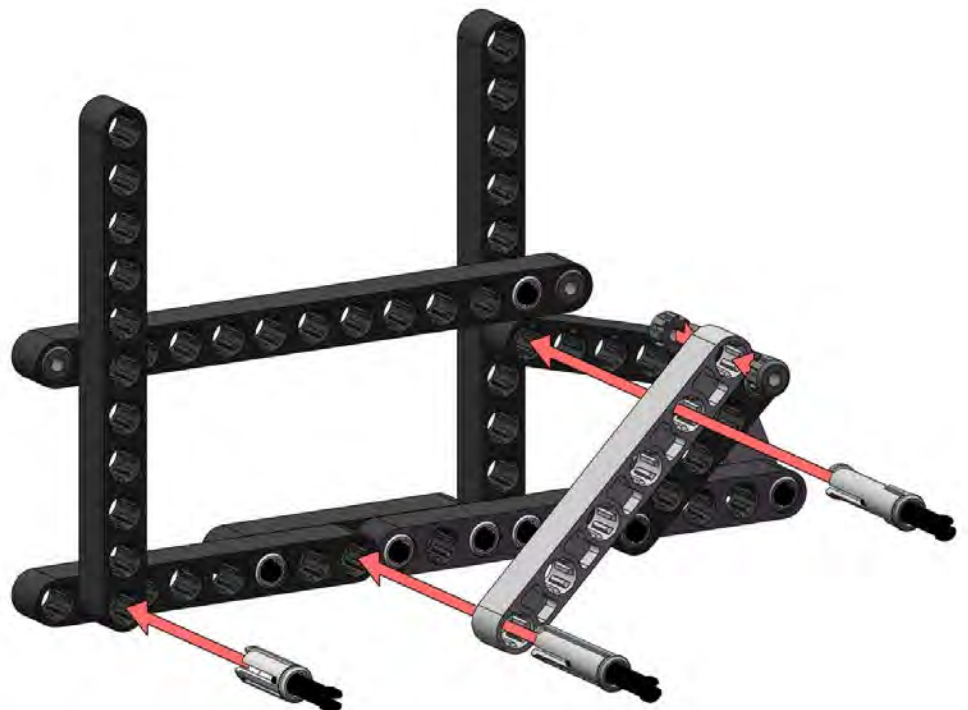

11

x2
2-45 BEAM

x6
TRANSITION

x6
3-LOCK

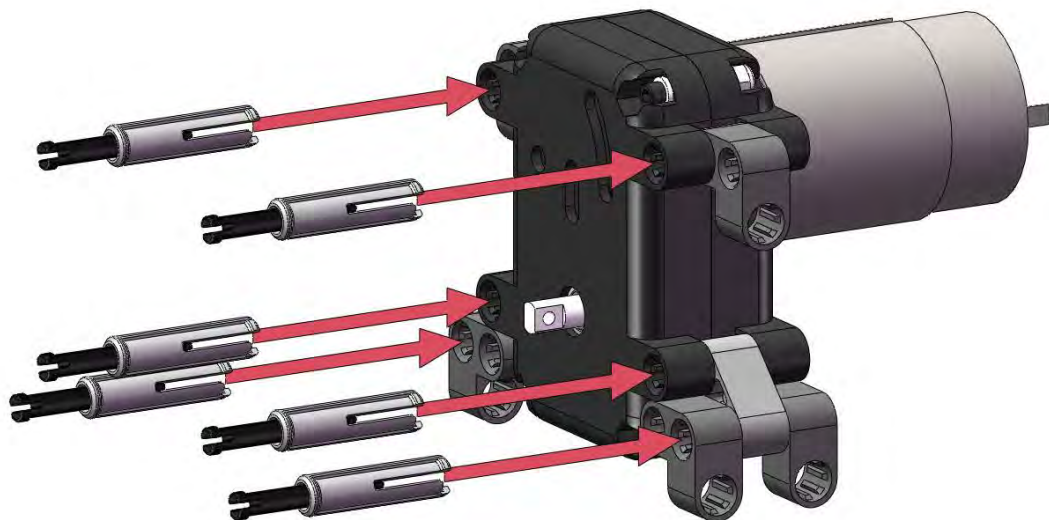

12

x6
2-LOCK

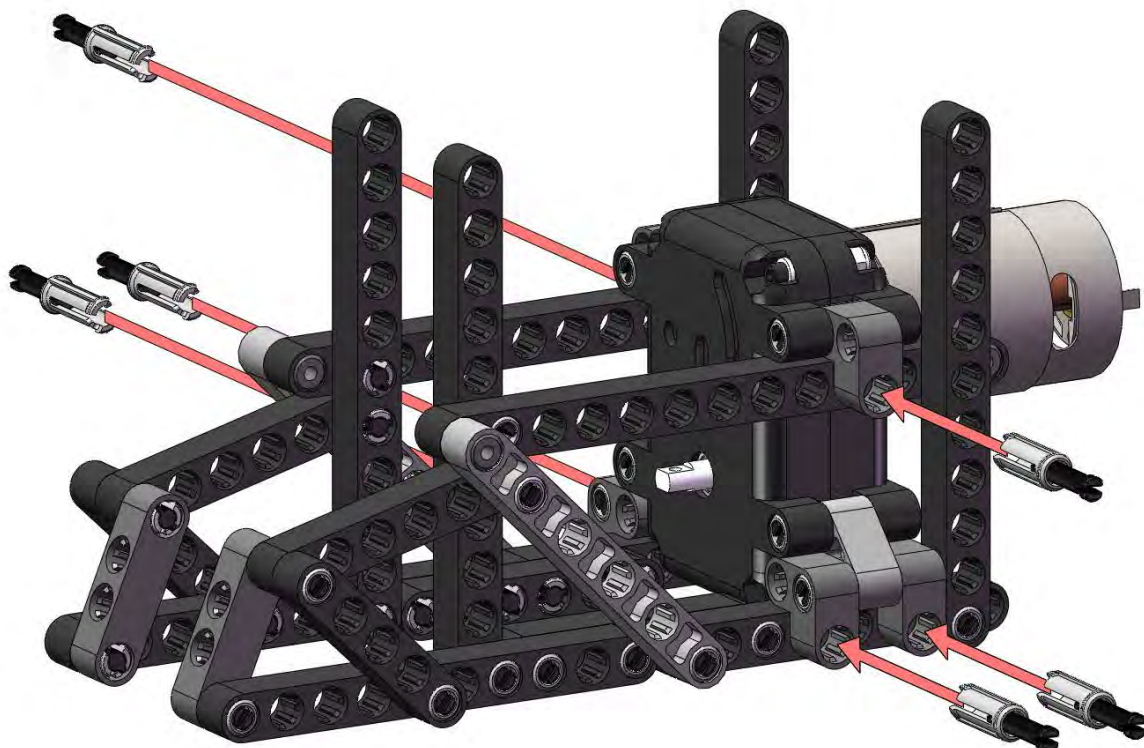

13

x2
3-DRIVELINE



x2
M4 WHEEL END SHAFT



x4
U-JOINT SET SCREW



14

x2
AXLE HOUSING



x2
STEERING BRACKET



x4
1.5-LOCK

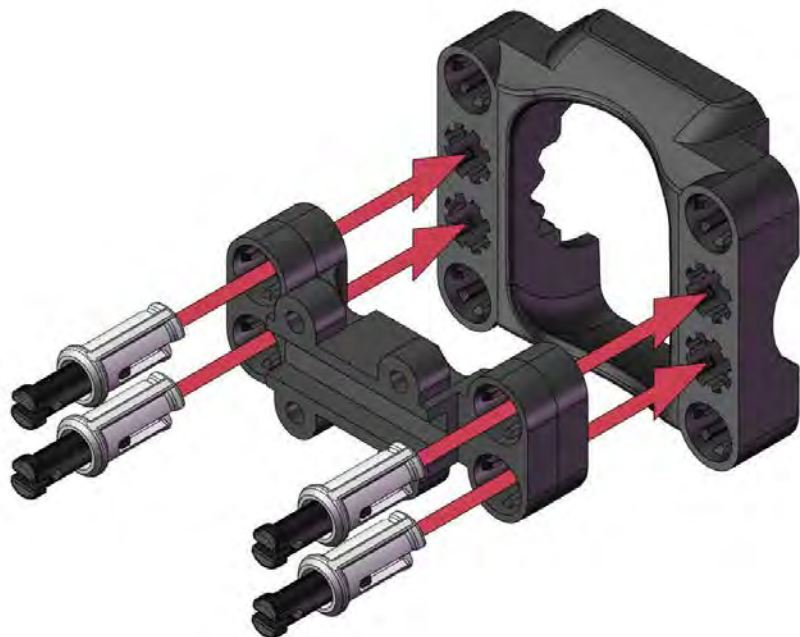

15

x1
STEERING BAR



x1
STEERING PLATE

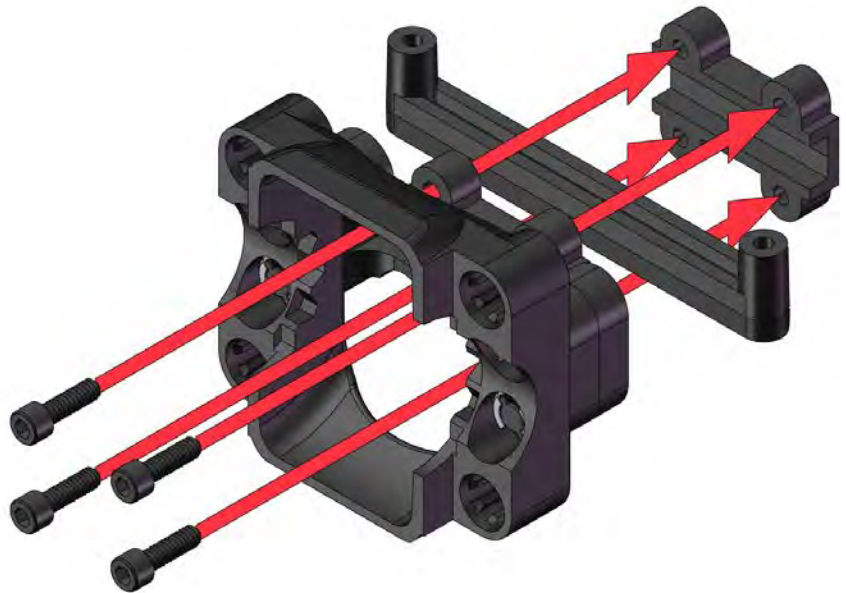

x4
#4-40 x 3/8" SCREW

16

x1
AXLE HOUSING



x2
SERVO MOUNT



x2
2-BEAM

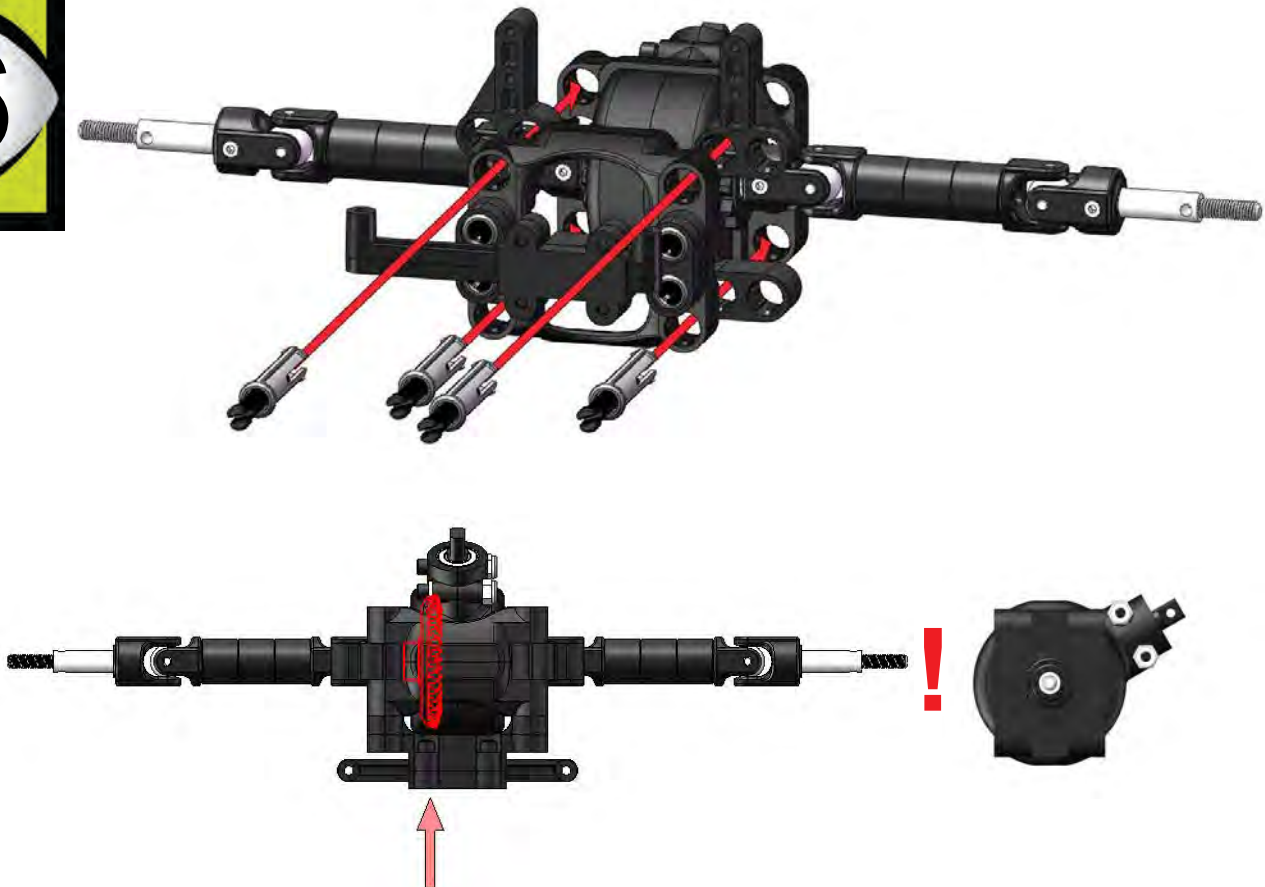

x4
3-LOCK

17

x1
HS-485HB SERVO

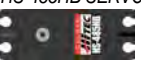

x4
SERVO BUSHING



x4
SERVO BUSHING SLEEVE

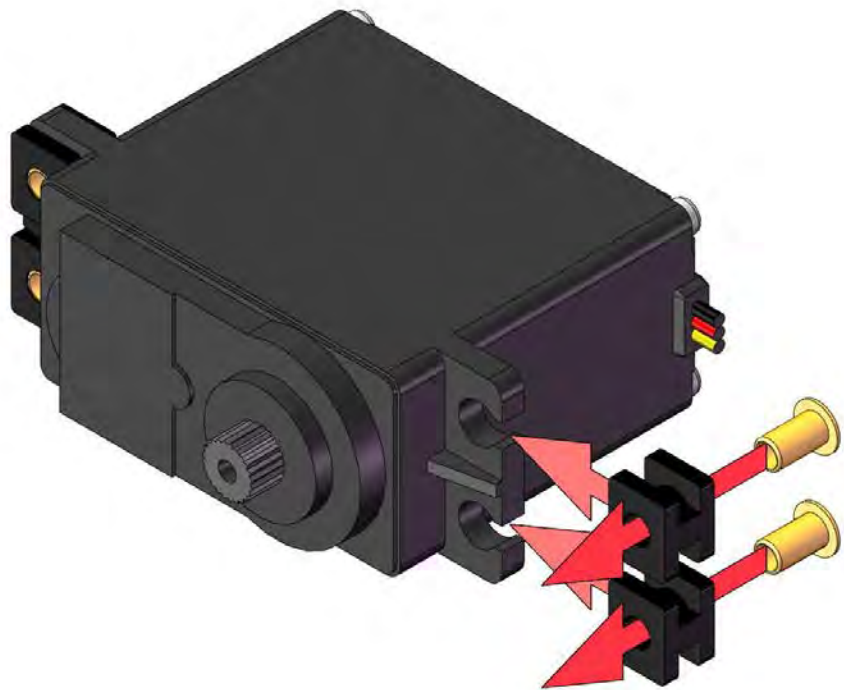

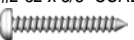

18

x4
#2-32 x 5/8" SCREW

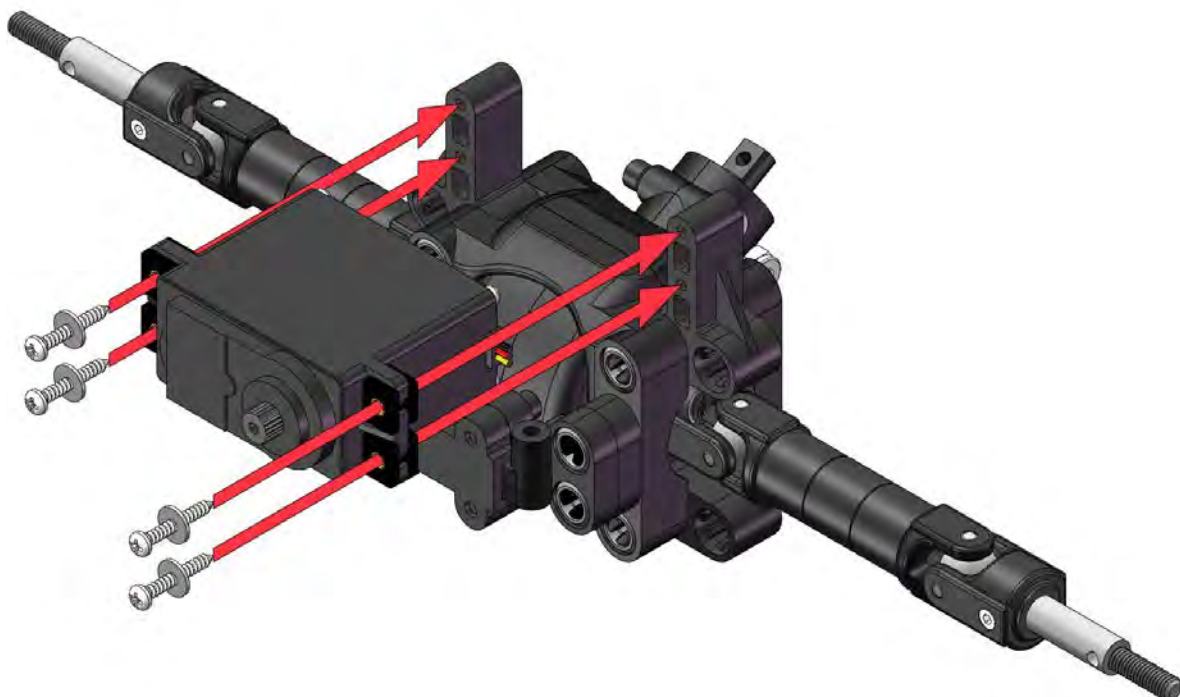

x4
#2 WASHER

19

x2
FRONT WHEEL HUB



x2
FRONT WHEEL KNUCKLE



x8
7-BEAM



x4
3-ROTATE



x4
6x12x4mm BEARING



x2
CLEARANCE THREAD ADAPTER



x2
INTERFERENCE THREAD ADAPTER



x2

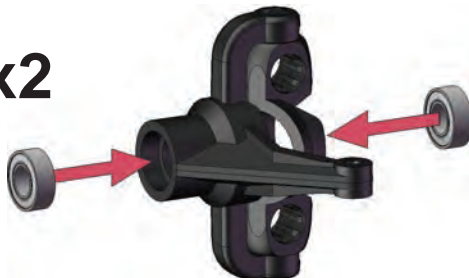

x2

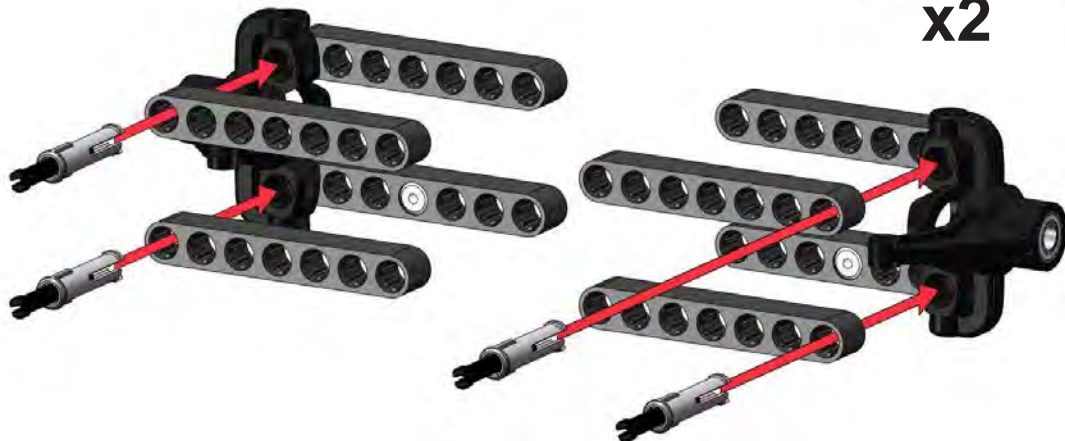

20

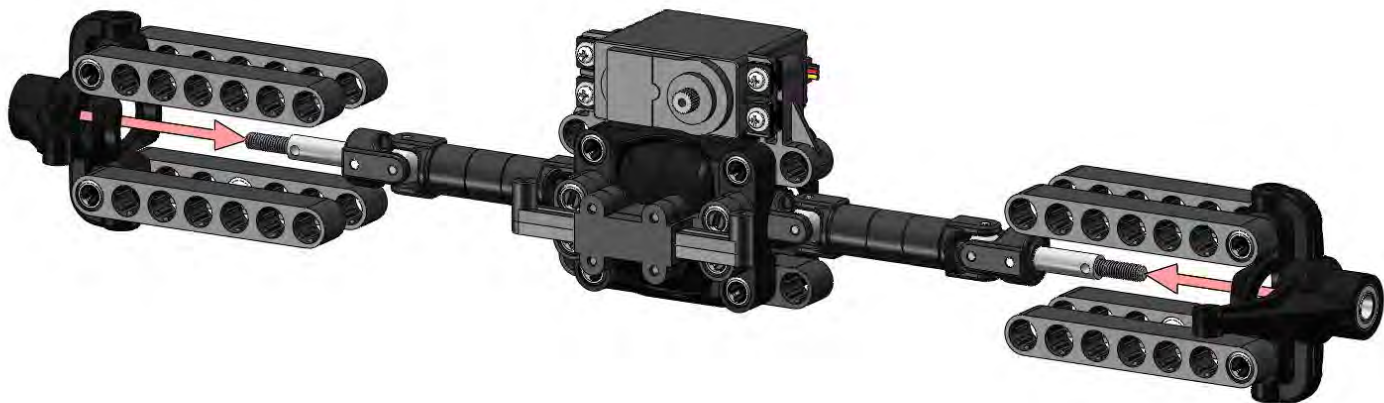



x4
3-ROTATE

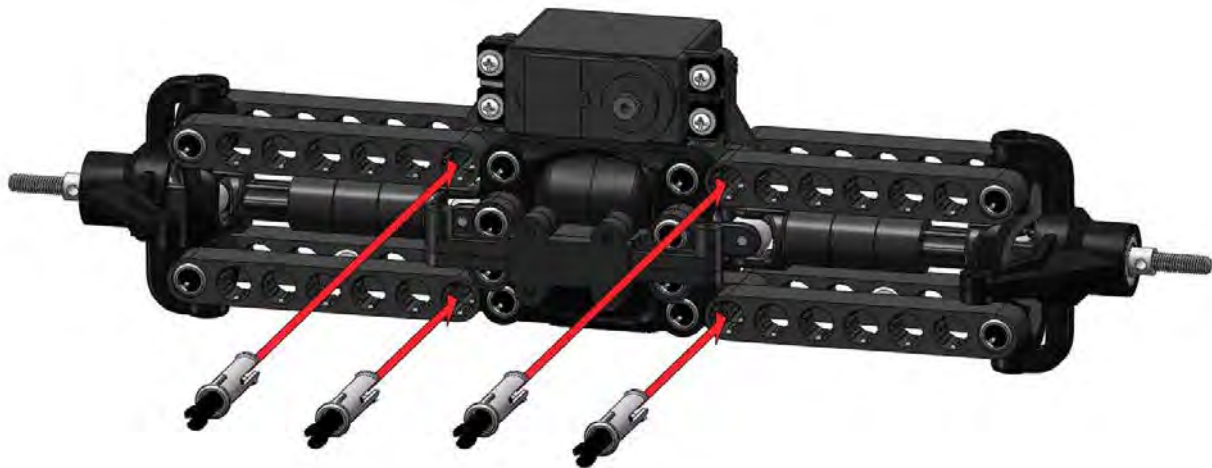

x5
3/16" BALL STUD

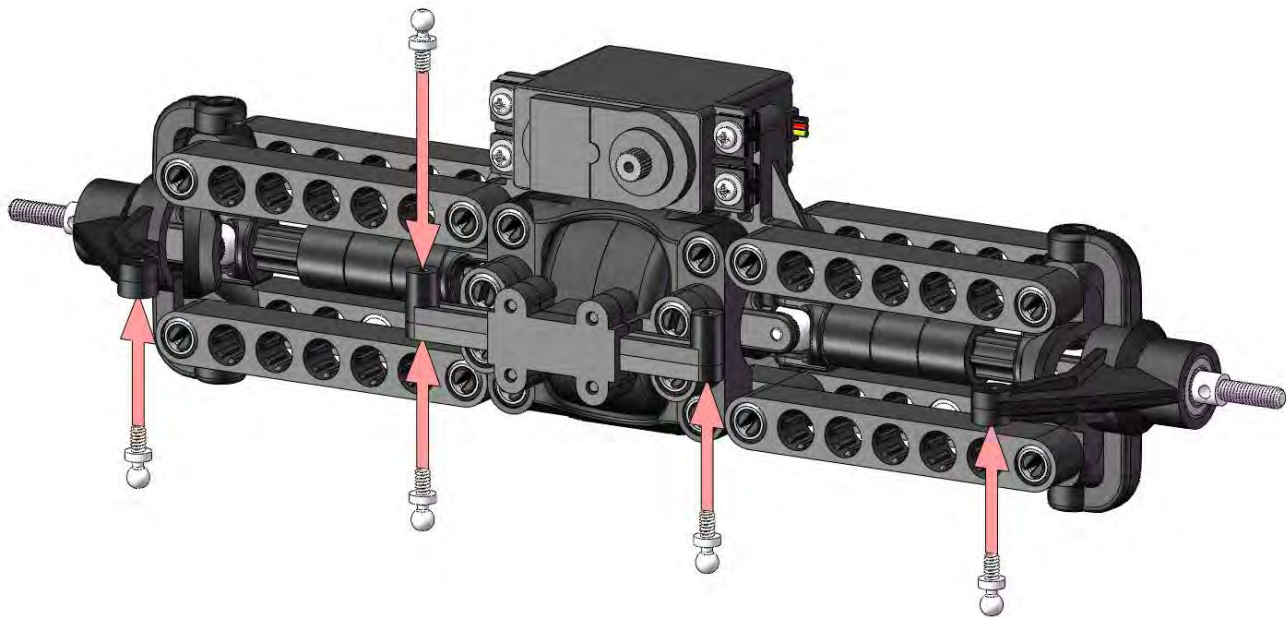



x2
#4-40 x 1-1/2" THREAD ROD



x4
23mm BALL CUP



=

1:1 SCALE



x2

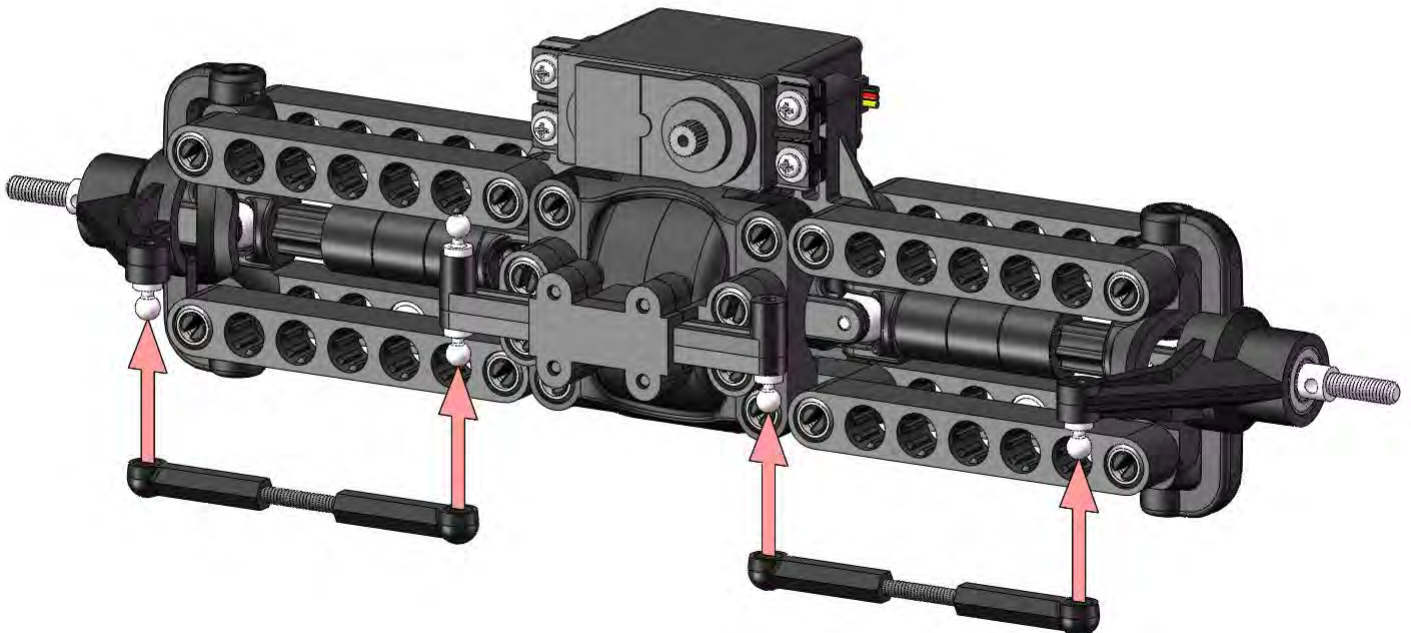



x1
#4-40 x 1" THREAD ROD

x2
18mm BALL CUP



=

1:1 SCALE



x1
STEERING SERVO HORN

x1
3/16" BALL STUD



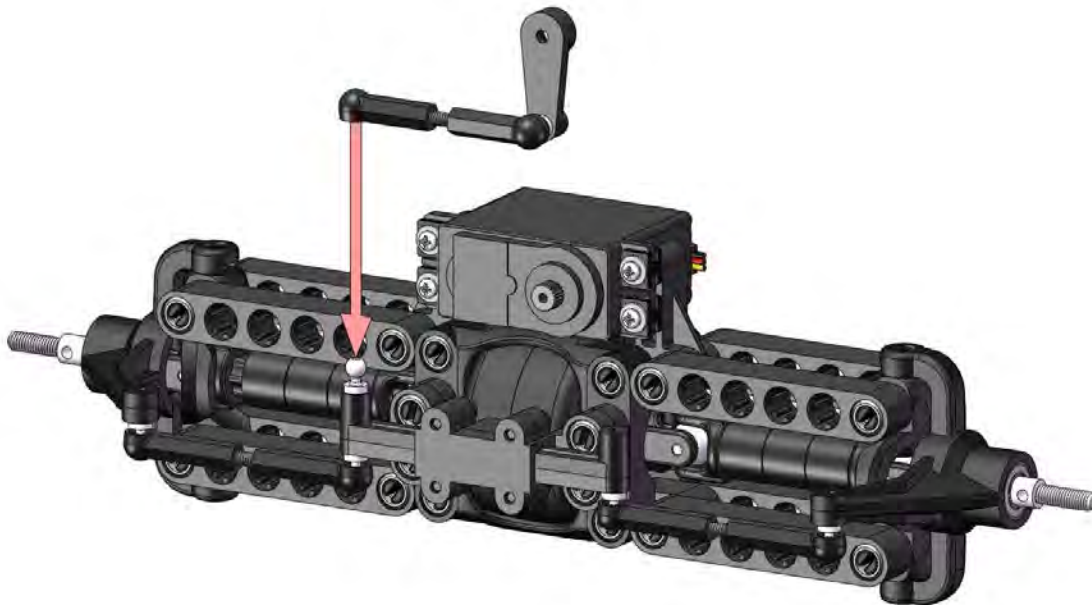

NOTE: REFER TO RADIO CONTROL SYSTEM INSTRUCTION MANUAL FOR PROPER SERVO SET-UP AND ADJUSTMENT



x1
SERVO HORN SCREW

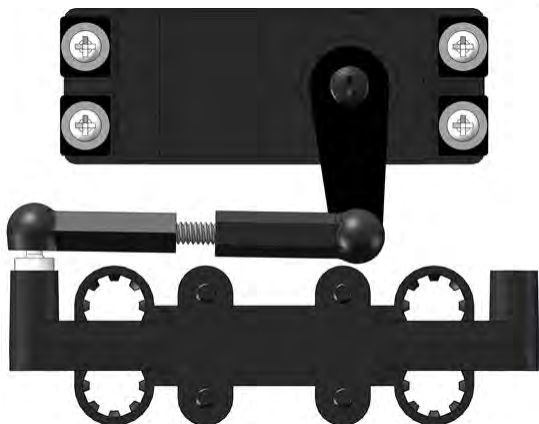
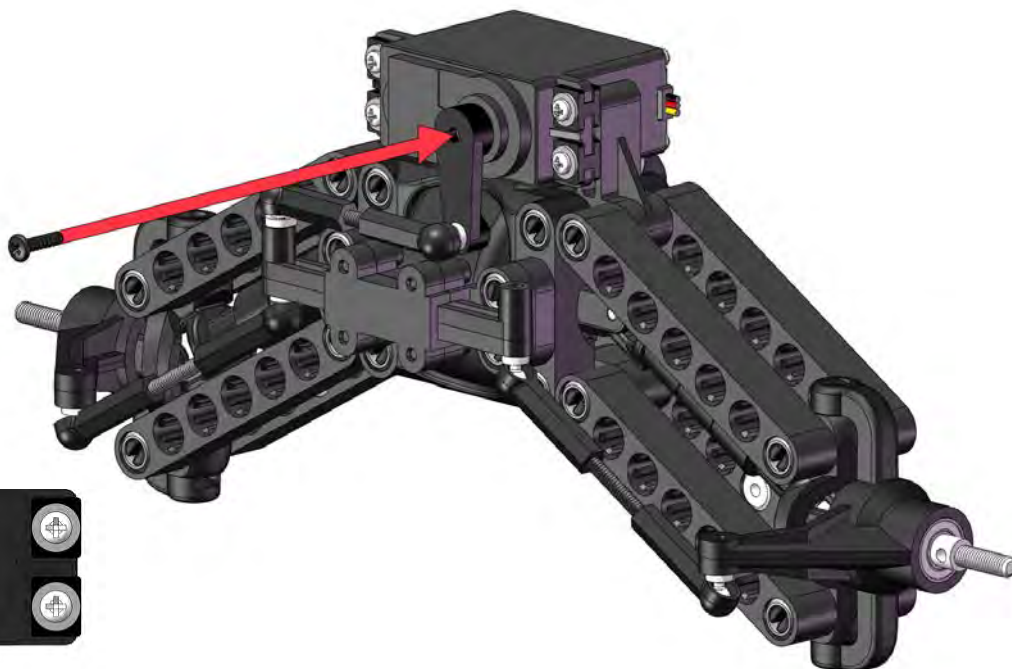

29

x2
12mm WHEEL NUT



x2
2.5x10mm DOWEL PIN

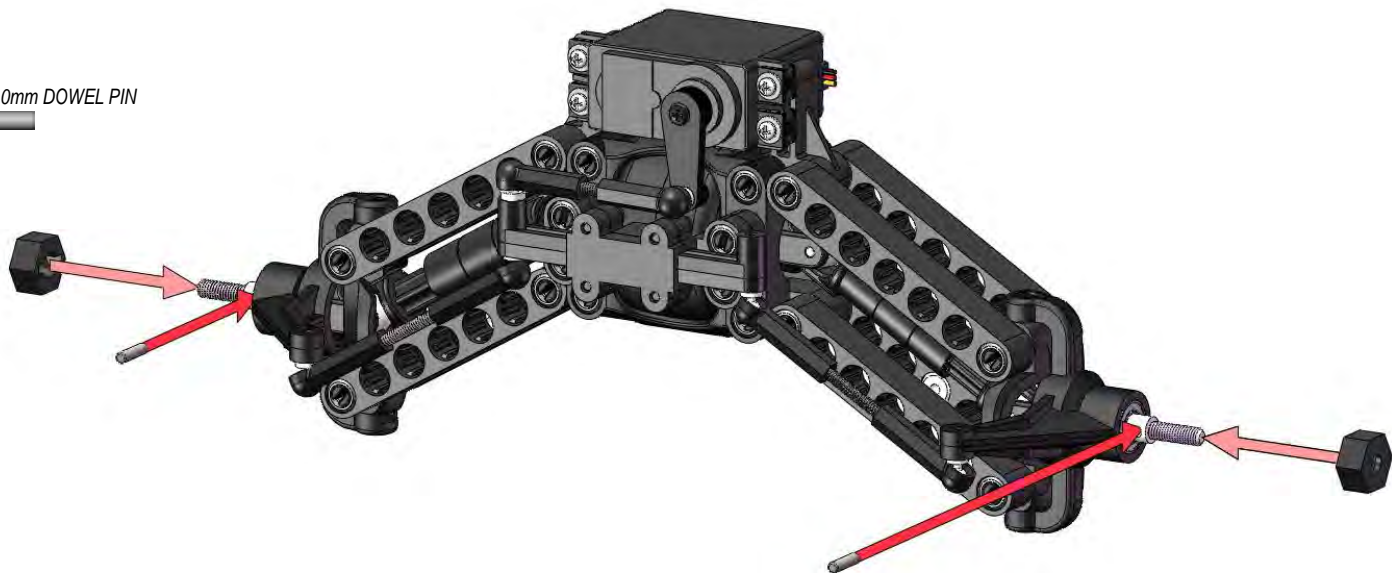

30

x4
1.5-LOCK

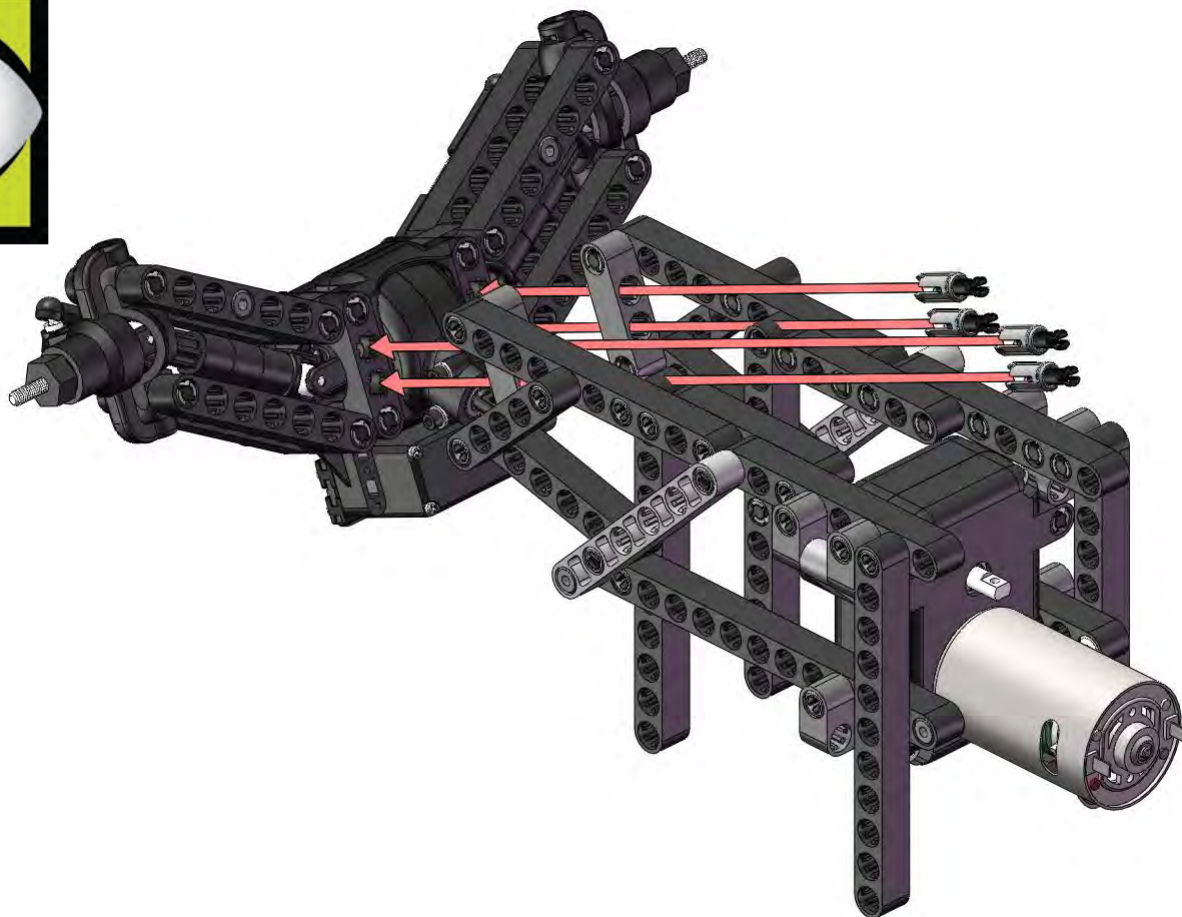



x2
3-DRIVELINE



x2
M4 WHEEL END SHAFT



x4
U-JOINT SET SCREW

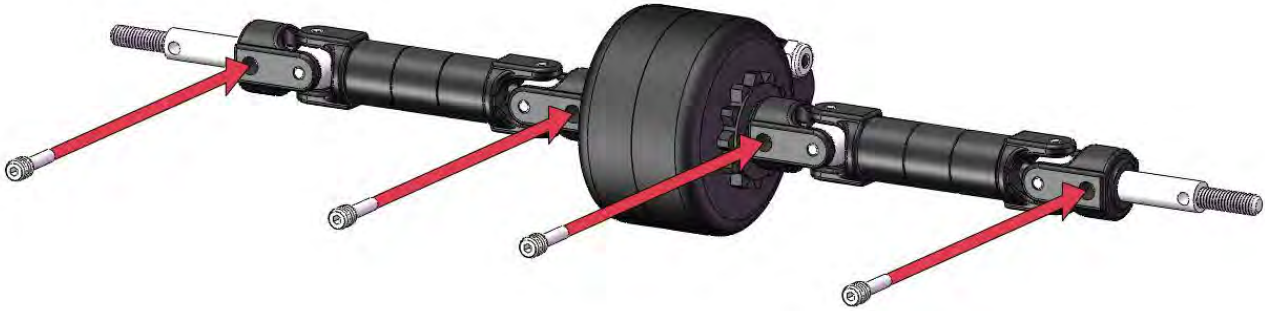

x2
AXLE HOUSING



x4
TRANSITION



x4
3-LOCK

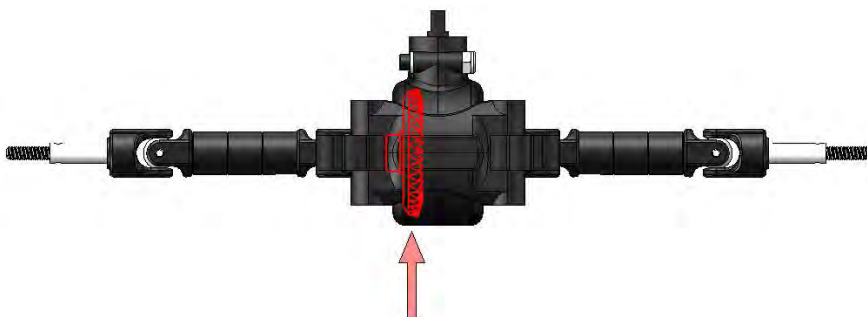

33

x2
13-BEAM



x2
6-BEAM



x4
2-LOCK

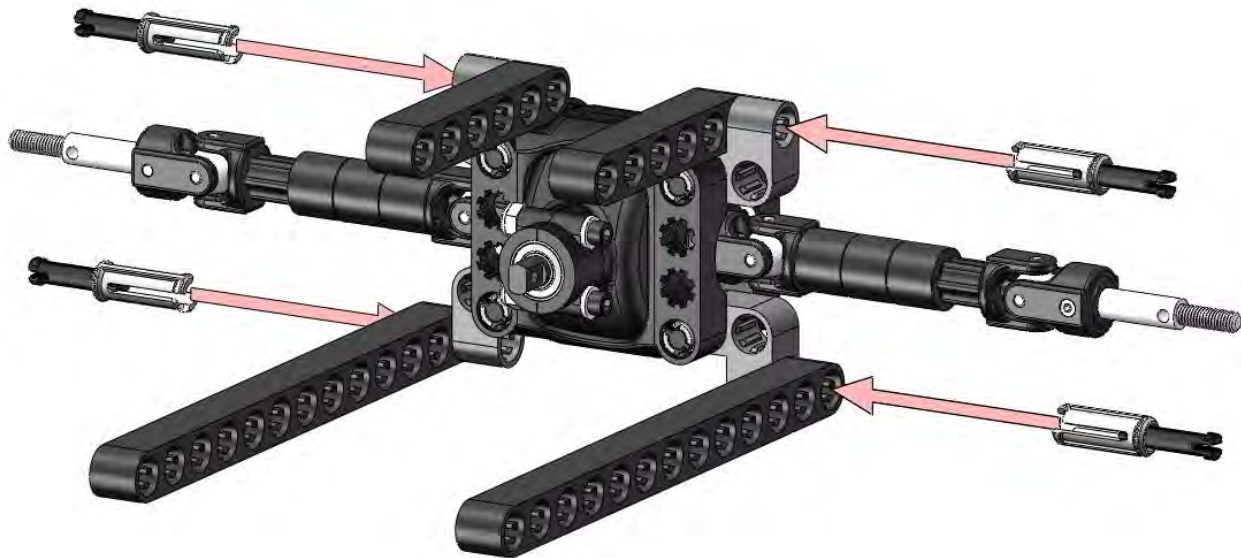

34

x2
DUAL TRANSITION



x4
1.5-LOCK

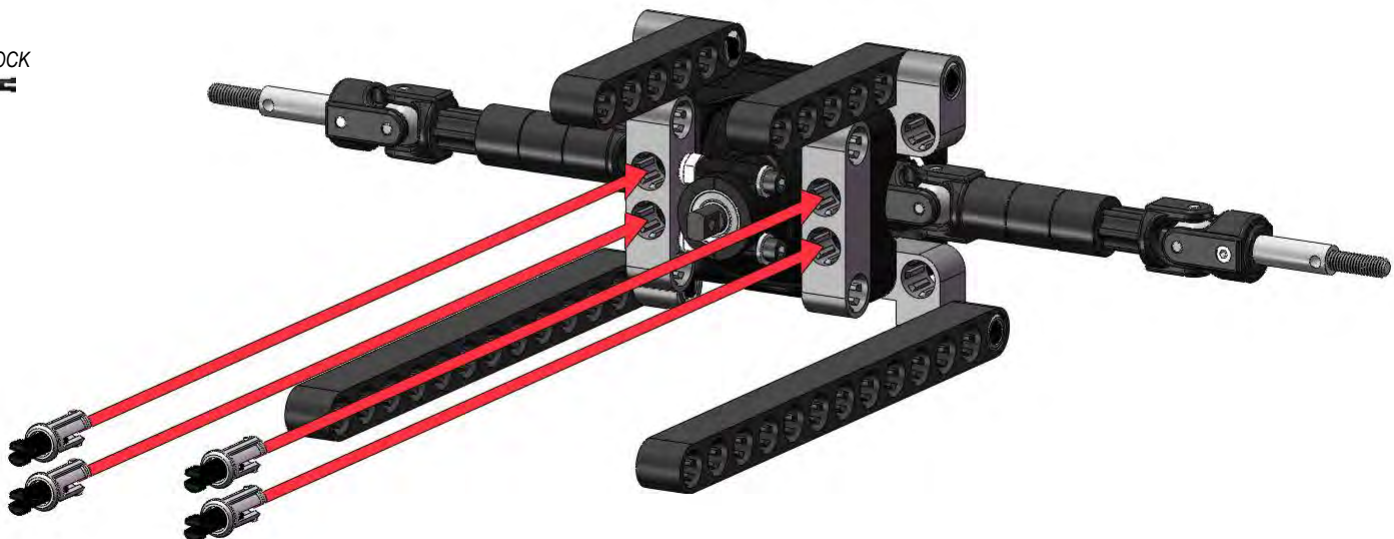

35

x2
6-BEAM



x8
2-LOCK

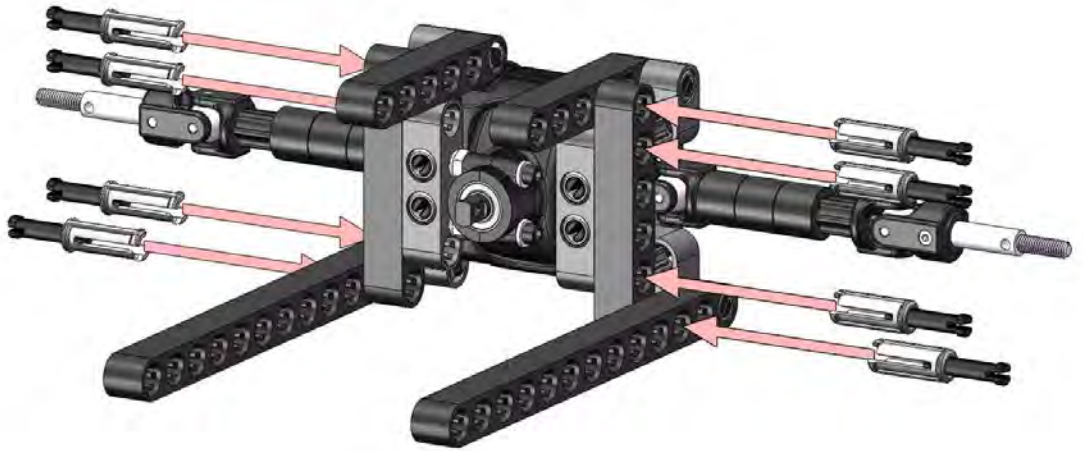

36

x4
TRANSITION



x4
2-LOCK

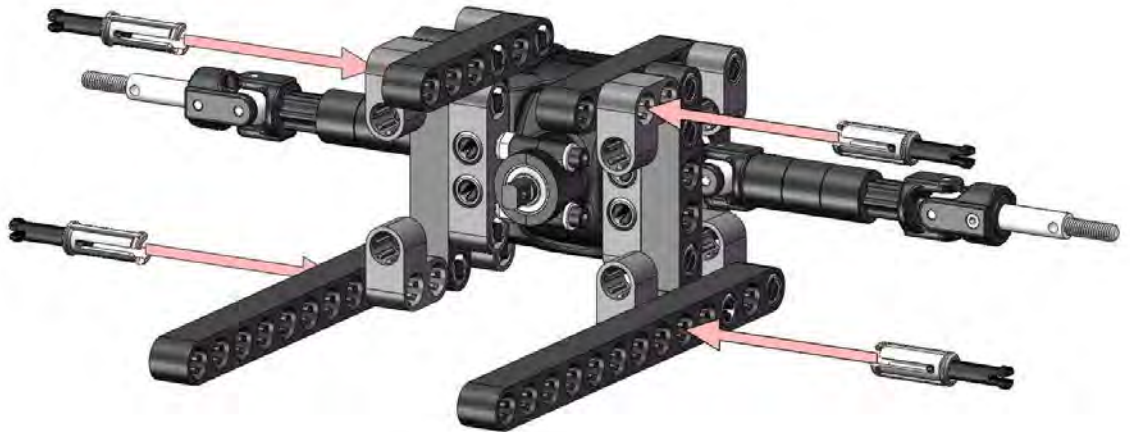

37

x2
REAR WHEEL HUB



x4
7-BEAM



x4
SUPPORT ARM



x4
3-LOCK



x4
6x12x4mm BEARING



38

x8
2-LOCK

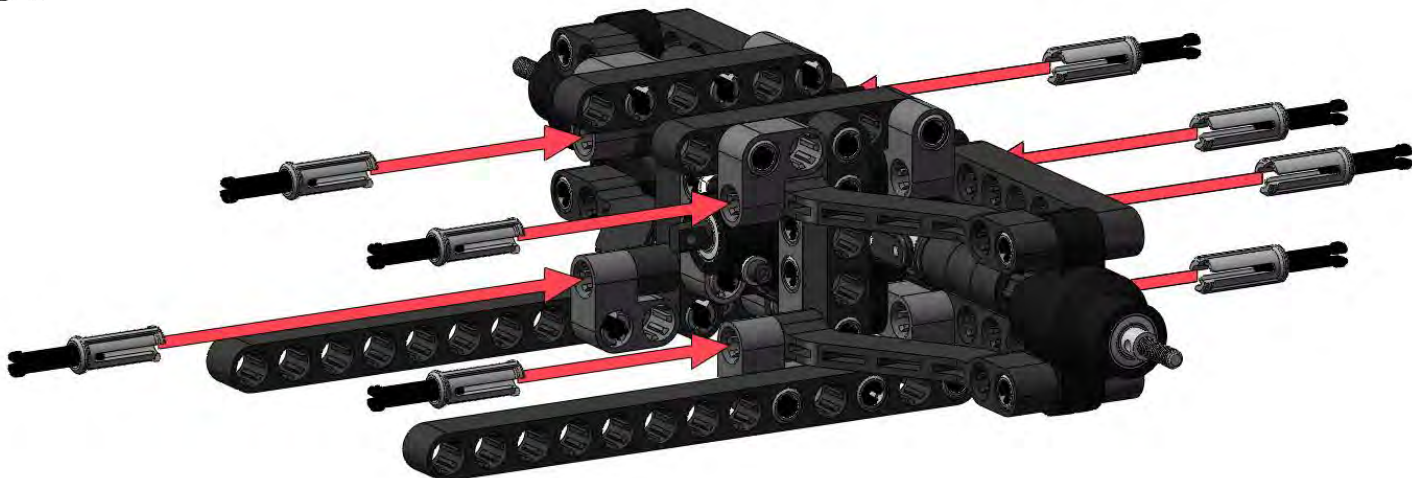

39

x2
6-45 BEAM



x4
2-LOCK

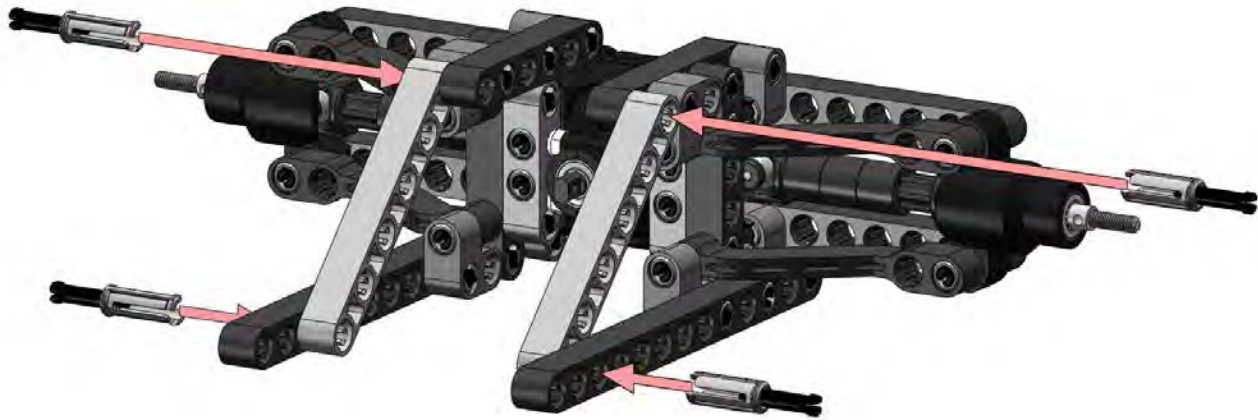

40

x4
CLEARANCE THREAD
ADAPTER

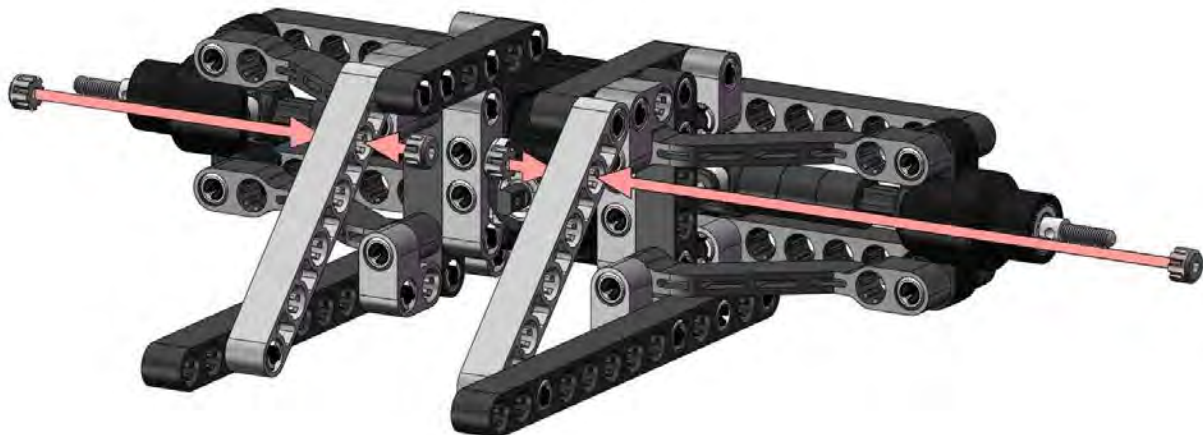

41

x2
BATTERY CAP



x4
TRANSITION



x2
3-LOCK



42

x4
2-LOCK



43

x2
12mm WHEEL NUT



x2
2.5x10mm DOWEL PIN



44

x2
2-ROTATE

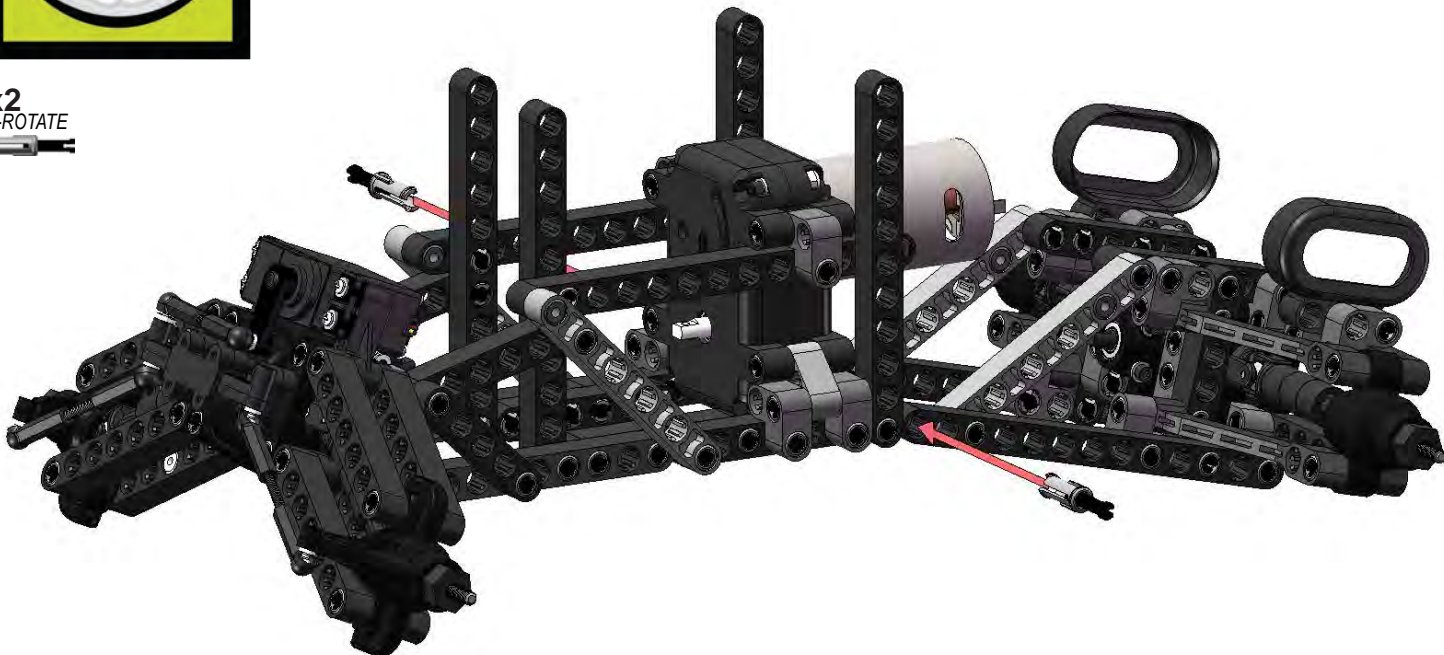

45

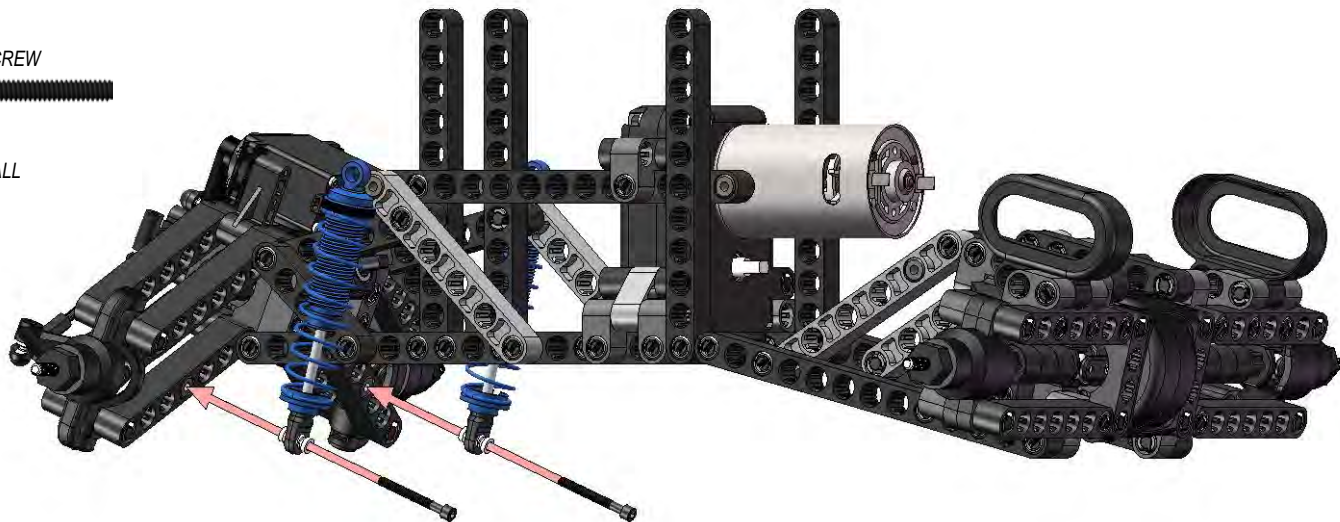
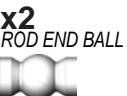
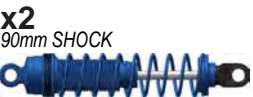

46



47

x2
90mm SHOCK



x1
2.0" THREAD COLLAR



x4
#4-40 x 1" SCREW



x2
#4 WASHER



x2
SHOCK MOUNT



x2
ROD END BALL



x2

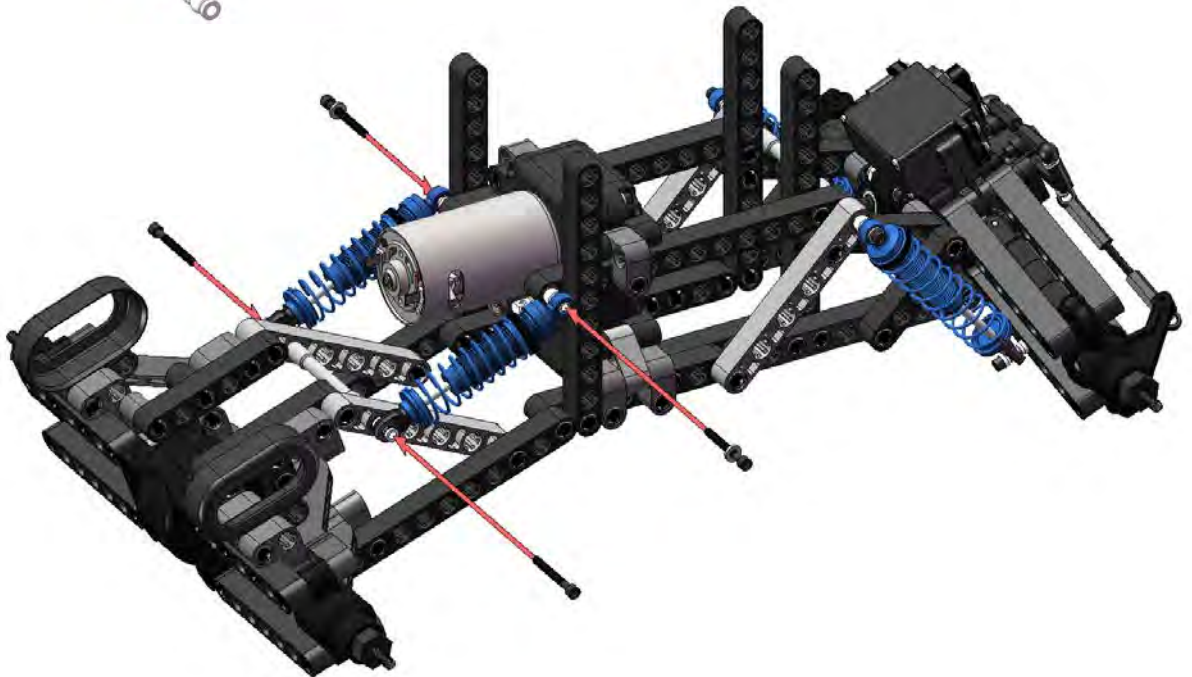

48

x2
15-BEAM



x2
9-BEAM



x8
2-LOCK



x2

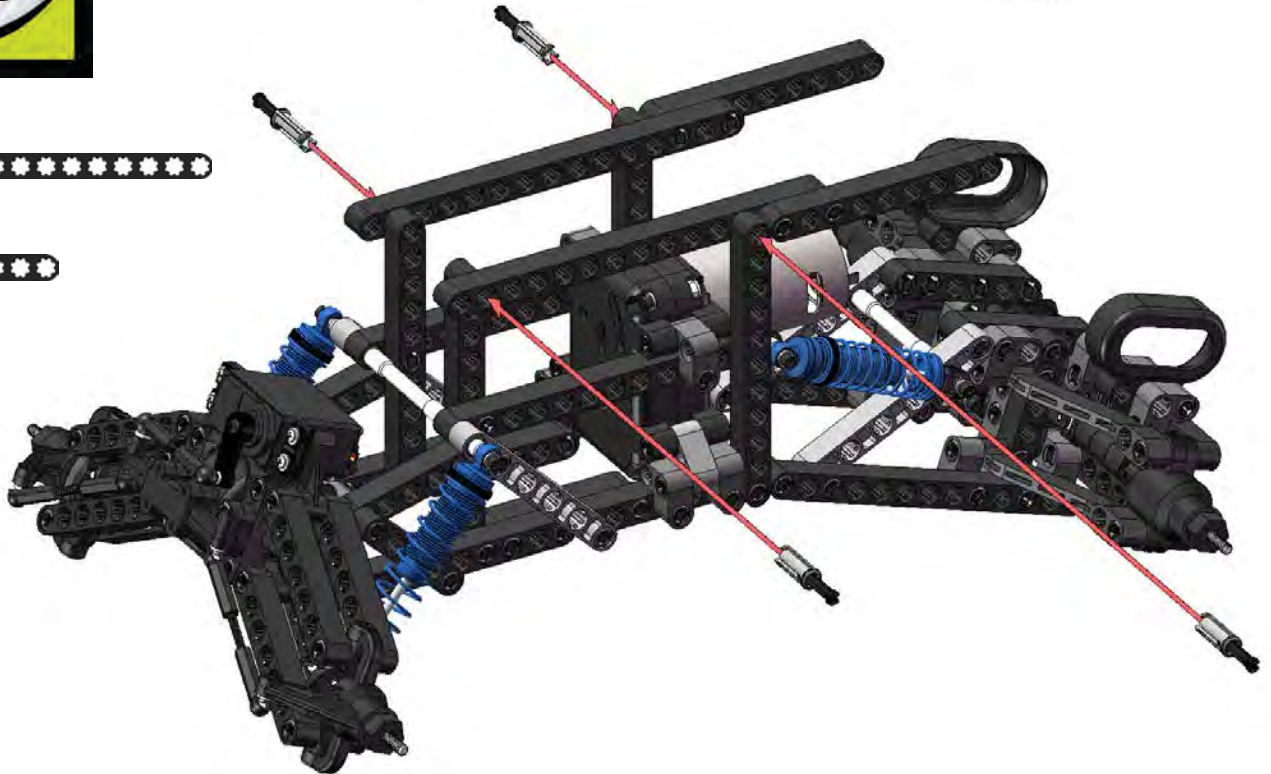

49

x2
9-BEAM



x2
9-45 BEAM



x4
TRANSITION



x2
3-LOCK



x8
2-LOCK

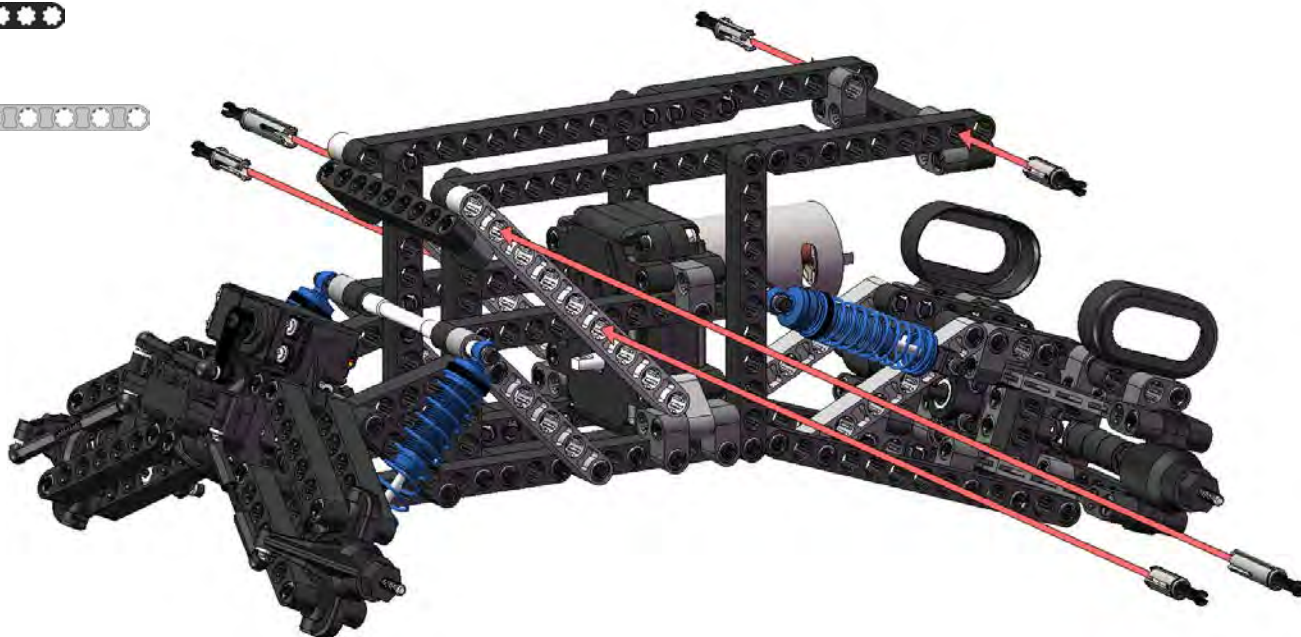
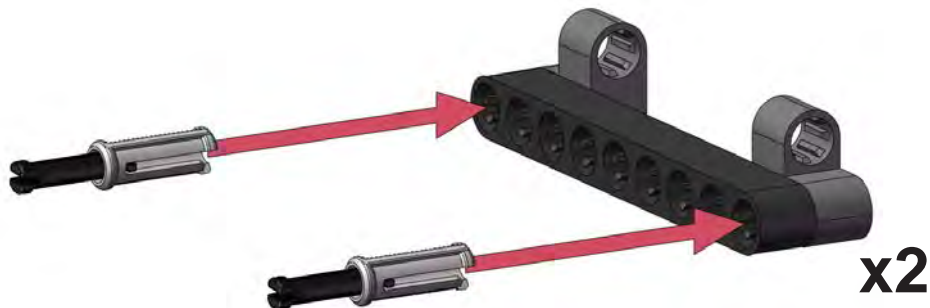

50

x2
9-45 BEAM



x2
3-LOCK



x4
2-LOCK

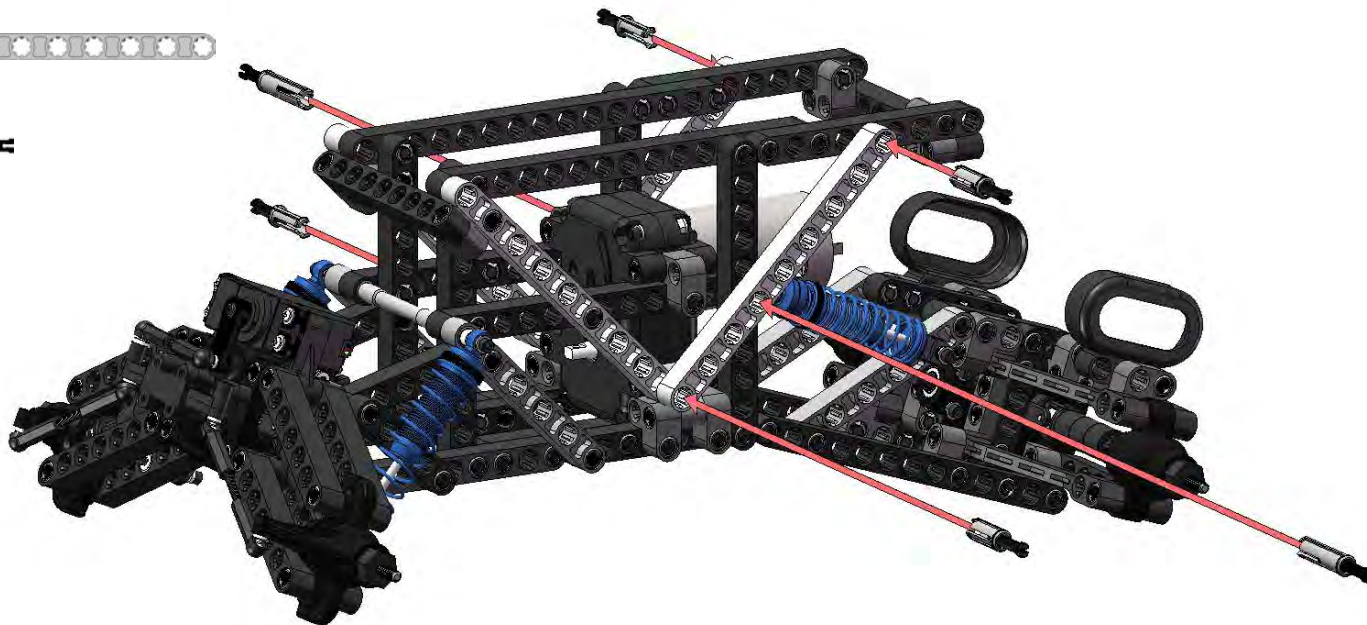

51

x2
5-DRIVELINE



x4
U-JOINT SET SCREW

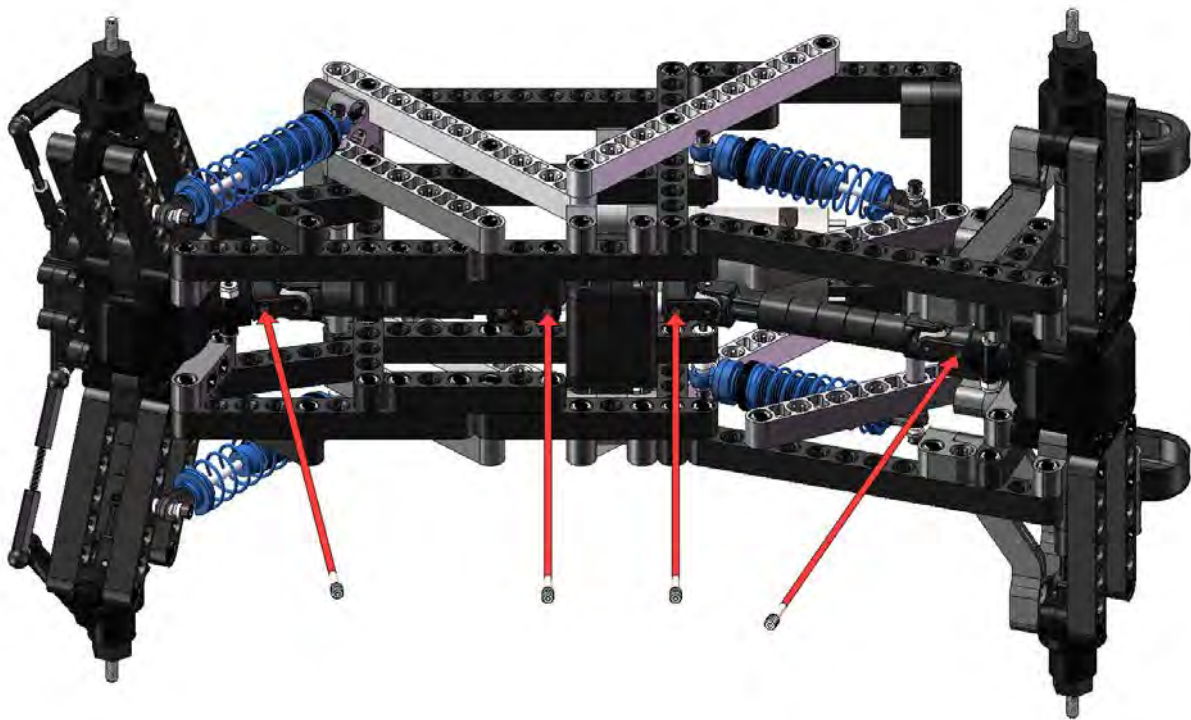

52

x4
BADLANDS 2.2" TIRE & DESPERADO WHEEL



x4
M4 WASHER



x4
M4 NUT

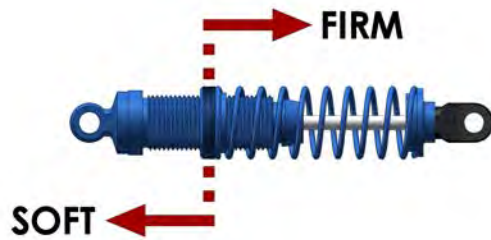



REFER TO RADIO TRANSMITTER MANUAL AND FOLLOWING DIAGRAMS FOR PROPER INSTALLATION AND SET-UP.

USING THE WIRE TIES AND DOUBLE-SIDED TAPE PROVIDED, PLACE THE ELECTRONIC COMPONENTS ON THE FRAME SO THAT THEY ARE SECURE AND OUT OF THE WAY OF MOVING PARTS.

BATTERY mAh _____ ÷ CHARGER mA _____ = ESTIMATED CHARGE TIME (IN HOURS)

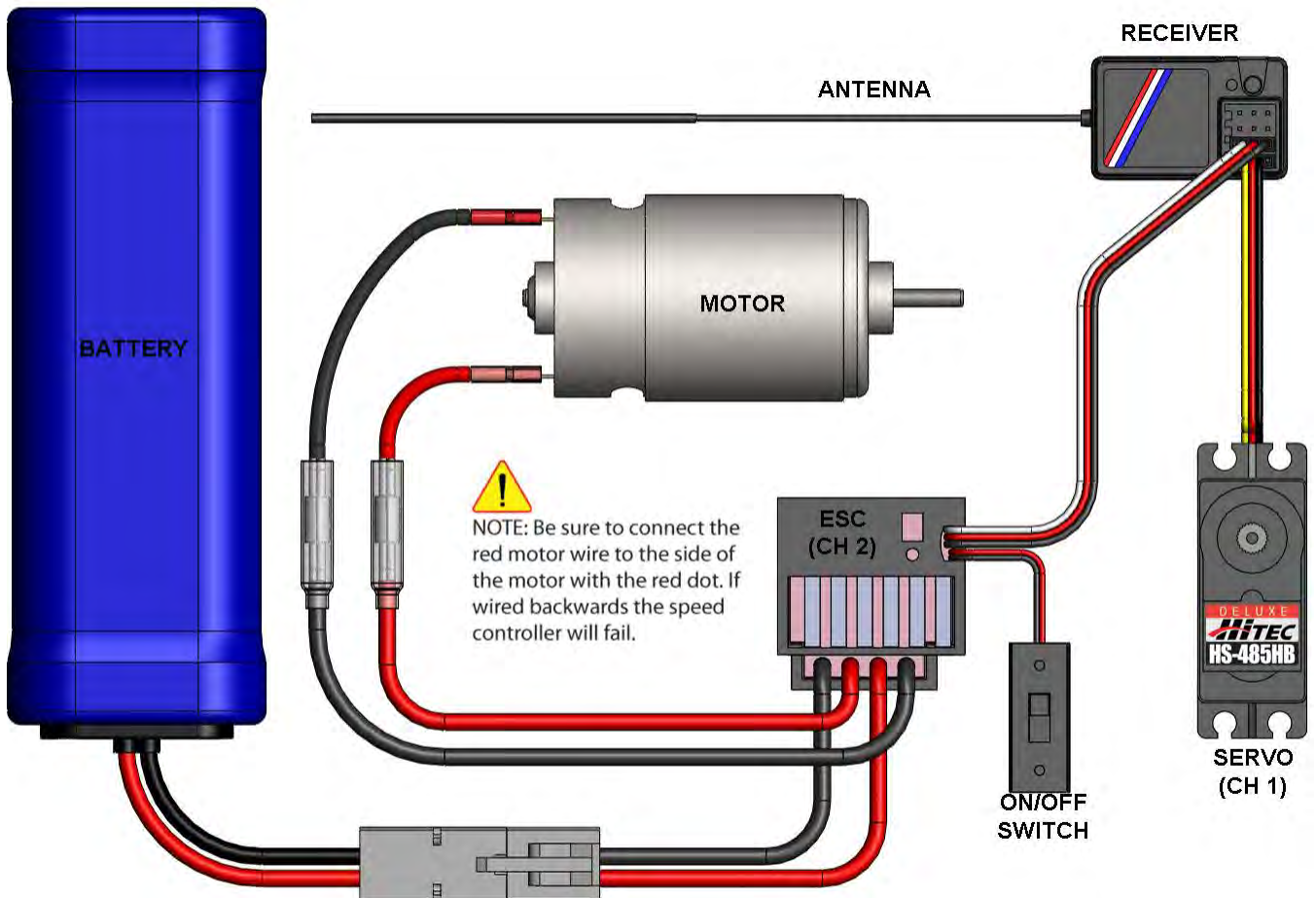

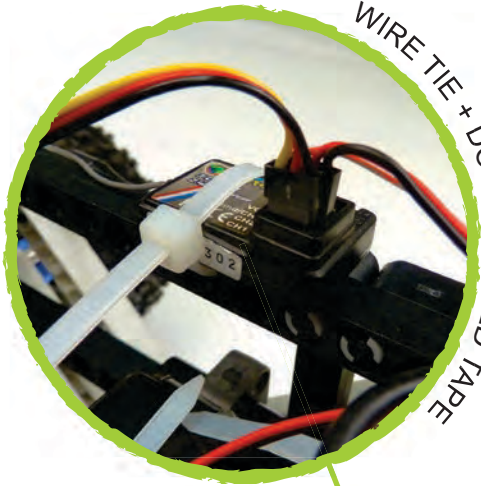

WIRE TIE + DOUBLE-SIDED TAPE



WIRE TIE

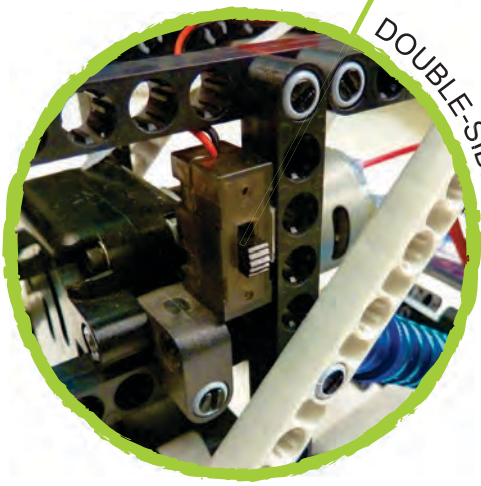
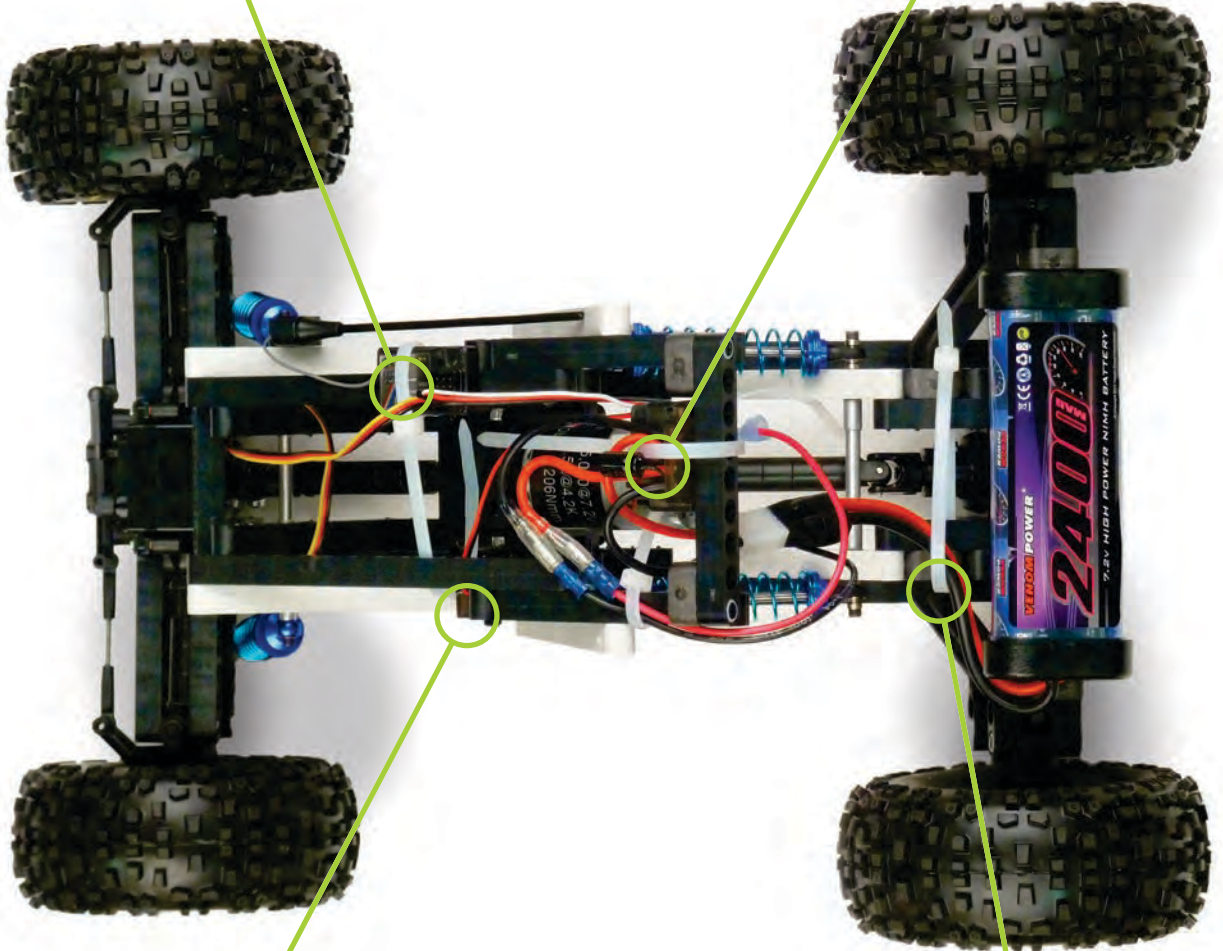

DOUBLE-SIDED TAPE



WIRE TIE

TROUBLESHOOTING GUIDE

PROBLEM	CAUSE	SOLUTION
<i>Wheels rotate backwards when forwards throttle is applied.</i>	1) One or more of your differentials are installed upside down.	1) Check the assembly instructions to make sure the differentials were installed correctly.
	2) The motor is spinning the wrong direction.	2) Check that the wires from the ESC to the motor are connected properly.
	3) The motor case was installed with the motor facing opposite of what the instructions show.	3) Check the assembly instructions to make sure the motor case was installed correctly.
	4) The "throttle" switch on your remote control may be switched to reverse.	4) Flip the switch to normal.
<i>Front wheels rotate opposite of rear wheels when driving.</i>	1) One of your differentials are installed upside down.	1) Check the assembly instructions for proper installation of the differentials.
<i>Vehicle doesn't drive in a straight line with the steering channel centered.</i>	1) Your steering trim is not centered.	1) Center your steering trim.
	2) Your servo horn was not installed on the servo while it was centered.	2) Remove the screw that retains the servo horn, then remove the servo horn. Turn the remote control on, center the trim on the remote, turn the vehicle on. Then reinstall the servo horn as the instructions show.
	3) The linkages that connect your steering bar to the front wheel knuckles are not the proper length or do not match each other.	3) Remove the linkages and check that they are the length indicated in your instructions.
	4) The "Y" harness for four wheel steering is not centered.	4) Follow step 2 for front and rear servo, making sure when you center the trim on the remote to also center the trim on the "Y" harness.
<i>Servo does not operate when steering is applied.</i>	1) Servo cable is plugged in upside down.	1) Check that the cable is plugged in according to the wiring polarity guide.
<i>Servo steers only one direction or farther one way than the other.</i>	1) Servo horn is not centered on the servo properly.	2) Remove the screw that retains the servo horn, then remove the servo horn. Turn the remote control on, center the trim on the remote, turn the vehicle on. Then reinstall the servo horn as the instructions show.
<i>Vehicle has become under powered or sluggish.</i>	1) Charge level of vehicle battery has dropped below useable level.	1) Remove battery from vehicle and charge with the recommended charger. Always follow proper safety procedures when charging a battery.
<i>Vehicle stops unexpectedly or doesn't respond to remote.</i>	1) Charge level of remote control batteries have dropped below useable level.	1) Check the remote control low battery indicator, if necessary replace or recharge batteries. Always follow proper safety procedures when charging a battery. Never recharge alkaline batteries.
	2) A wire may have come loose from the receiver.	2) Check that the wires are all properly plugged in and in good condition.
<i>Vehicle does not move forward or reverse when throttle is applied but audible tone comes from motor</i>	1) Something has become bound up in the drivetrain.	1) Check the drivetrain from motor to wheels for foreign objects and debris. Removing the drivelines that connect the motor case to the differential(s) then trying to spin the wheels will allow you to more easily locate the issue.
<i>Motor spins freely when throttle is applied but vehicle doesn't move.</i>	1) Gear mesh in motor case was not properly set.	1) Check that the gear mesh was set according to the instructions. Gears should be about the thickness of this sheet of paper apart for proper mesh.
	2) Pinion set screw was not Properly tightened.	2) Check that the pinion set screw was tightened according to the instructions.

ARDUINO TROUBLESHOOTING GUIDE

PROBLEM	CAUSE	SOLUTION
<i>Vehicle is not behaving as programmed.</i>	1) Charge level of vehicle battery has dropped below useable level.	1) Remove battery from vehicle and charge with the recommended charger. Always follow proper safety procedures when charging a battery.
	2) Inputs (sensors) or Outputs (servos, ESC, etc) are wired improperly.	2) Check that each device connected to the Arduino Sensor Shield is plugged in properly. Both in polarity and into the proper port the program states.
	3) Sensor is malfunctioning.	2) Check #2, Connect Arduino to computer using USB cable, run the calibration program for each sensor on the vehicle. If the sensor value is not present, uncharacteristic or erratic the sensor may need to be replaced.
<i>Serial port "COM_" not found.</i>	1) The Arduino is not connected to the computer.	1) Connect the supplied USB cable and try again.
	2) The proper serial port was not selected in the Arduino Program.	2) Disconnect, re-connect the USB Cable then go to Tools > Serial Port then select the Arduino Uno.
<i>Light on Ping))) sensor is not cycling.</i>	1) The Ping))) sensor is not wired properly.	1) Check the wiring polarity guide for proper installation.
	2) The Ping))) sensor in not connected to the proper port.	2) Check that the sensor is plugged into the port stated in the code.
<i>QTI sensors not detecting line.</i>	1) The QTI sensor is not wired properly.	1) Check the wiring polarity guide for proper installation.
	2) The QTI sensor in not connected to the proper port.	2) Check that the sensor is plugged into the port stated in the code.
<i>Power light on Arduino Sensor Shield doesn't turn on when ESC is powered on.</i>	1) One of the connections to the Sensor Shield is shorted.	1) Check that each device connected to the Arduino Sensor Shield is plugged in properly. Both in polarity and into the proper port the program states. If the problem persists disconnect one sensor at a time till the faulty connection (sensor, servo, ESC etc.) is found, then replace.
	2) No power source is connected to the Arduino.	2) Check to make sure that it is either plugged into your computer with the USB cable or that you are using a charged battery and the ESC cable is properly connected.

<http://arduino.cc/en/Guide/Troubleshooting>



®

*injection-molded
plastic*

For technical questions or to place an order:

Phone: (509) 252 - 5767

Fax: (509) 924 - 2219

Email us at:

info@myminds-i.com

Write to:

ATTN: MINDS-i Inc.
22819 East Appleway Avenue
Liberty Lake, Washington 99019

For the latest from MINDS-i visit:

minds-irobotics.com

For the most up to date version of the instructions go to:

minds-irobotics.com/instructions