



INSTALLER REFERENCE GUIDE

Rev 1.3



RF159 2 Channel SMART RF Controller - 433MHz



RF159 - 2CH SMART RF CONTROLLER - 433MHZ

The 2 Channel SMART RF Controller is an advanced 433MHz stand-alone transceiver that can be used to arm/disarm an alarm system and operate an auto gate or garage door. The two relay outputs are fully programmable and controlled by up to 250, RF110 Keyfobs.

The unit is compact so it can easily fit inside a gate controller cabinet or can be mounted easily to most surfaces. The wide operating voltage 9 to 28 volts AC/DC makes it easy to power from third-party controllers or power supplies.

This unit also compliments the Digiflex RF family allowing you to control different devices in diverse locations using the same Digiflex Smart RF Keyfobs.

The 2-way communication protocol is encrypted with rolling code and anti substitution technology making the RF159 an ideal choice for controlling gates, garage doors, lights or security systems.

Box Contents

The RF159 box contains the following parts.

2CH SMART RF Controller
1x Antenna
Instruction Sheet

Compatible Keyfobs

RF110 Smart 5 Button Keyfob
RF110FK - Colour Facia Kit One Of Each Colour
(Red, Blue, Green, Orange, Black, Grey, Yellow)



Figure 1: RF110 Smart 5 Button Keyfob

Mounting Considerations:

- The receiver should be mounted in a location at least 2m from other receivers.
- The receiver should be mounted on a vertical surface with at least 30 cm clearance from metal objects.
- Avoid mounting the receiver in areas with significant metal or electrical wiring.
- Avoid mounting the receiver in areas where it may be exposed to moisture or high humidity.
- Reception distances are generally improved with higher mounting locations and with no metal objects near the unit.
- If range is not achievable due to environmental or specification limitations then look at relocating the unit to a more appropriate location.

Defaulting

There are 3 default modes which allow you to manage and reset the settings as needed.

Default Mode 1: Factory Default

- Hold down both RLY1 & RLY2 while applying power.
RLY1 = Pulse 2 seconds
RLY2 = Pulse 2 seconds
Keyfobs: All Deleted

Default Mode 2: Erase only keyfobs that have not been used in the last 60 days.

- Hold down RLY1 while applying power.
RLY1 = No Change
RLY2 = No Change
Keyfobs: Deleted If Not recently Used

Default Mode 3: Erase all Keyfobs

- Hold down RLY2 while applying power
RLY1 = No Change
RLY2 = No Change
Keyfobs: All Deleted

Receiver Operation

The RF159 will turn on the green RX LED to indicate the unit is powered and it will blink off each time a signal is received. Each time a keyfob button is pressed the corresponding relay will operate and a confirmation signal is sent to the keyfob to indicate a successful 2 way transaction. When button RLY1 or RLY2 are triggered manually they operate the corresponding relay to allow you to test your connections and device your operating.

WARNING always be sure to check that there is no objects in the way when operating an automatic device as this could cause damage or injury to a person.

Relay Programming

RLY1 and RLY2 can be individually programmed to operate in pulse or toggle mode by selecting the corresponding mode number. Pulse mode is available in different timings from 1 second to 120 seconds to allow easy interface to automatic gates and doors . Toggle mode will operate the relay when the keyfob button is pressed and will release the relay on the next keyfob button press.

Program Relay Functions				
Action	Steps	LED's	Comment	
1	Enter Relay Programing Mode	Press RLY1 and RLY2 For 4 seconds	RF: ON PGM: ON RLY1: ON RLY2: ON	
2	Selecting The Relay	Press Relay Button To Select (E.g. RLY1)	RF: ON PGM: ON RLY1: Pulse current mode RLY2: OFF	
<i>RLY1 LED will flash the number of times corresponding to the currently programmed setting.</i>				
3	Set Relay Mode	Press Relay Button To Change Mode (E.g. RLY1)	RF: ON PGM: ON RLY1: Pulse current mode RLY2: OFF	
<i>RLY1 LED will flash the number of times corresponding to the currently programmed setting, pause then repeat. Each time you press RLY1 it will increment to the next mode as follows. 1=1s, 2=2s, 3=3s, 4=4s, 5=5s, 6=10s, 7=20s, 8=60s, 9=120s, 10=toggle</i>				
4	Program Other Relay	Press Relay Button To Select (E.g. RLY2)	RF: ON PGM: ON RLY1: OFF RLY2: Pulse current mode	
<i>RLY1 LED will flash the number of times corresponding to the currently programmed setting, pause then repeat. Each time you press RLY1 it will increment to the next mode as follows. 1=1s, 2=2s, 3=3s, 4=4s, 5=5s, 6=10s, 7=20s, 8=60s, 9=120s, 10=toggle</i>				
5	Exit Programming Mode	Press RLY1 and RLY2 for 1 seconds or timeout after 60 seconds	RF: On PGM: OFF RLY1: OFF RLY2: OFF	
<p>LED Legend</p>				

Table 1: RF159 Relay Programming

Learning Keyfobs

A total of 250 keyfobs can be learnt, for example you can have 250 different keyfobs operating RLY1 or RLY2. You can also spread the 250 keyfobs across both RLY1 and RLY2 using different buttons. The same keyfob can not be programmed to operate the same relay using 2 different buttons. If a keyfob button is already learnt to RLY1 and you learn a different button on the same Keyfob to RLY1 then the original button is overwritten by the new button. While learning keyfob buttons to the relays you can easily learn one keyfob to RLY1 then learn a different button to RLY2 after each other and then learn new keyfobs after each other.





















Learning a Keyfob				
Action	Steps	LED's	-	
1	Enter Keyfob Learn Mode	Press RLY1 and RLY2 for 1 second	RX: ON PGM: ON RLY1: Flash RLY2: Flash	 RF  RLY1  PGM  RLY2
2	Selecting The Relay	Press Relay Button To Select (E.g. RLY1)	RX ON PGM ON RLY1: ON RLY2: OFF	 RLY1  RF  PGM  RLY2
3	Learn Keyfob Button to Relay	Press desired keyfob button to learn	RX: Acknowledged with a single pulse PGM: ON RLY1: Flash RLY2: Flash	 RF  RLY1  PGM  RLY2
To program another keyfob or button go to step 2.				
4	Exit Programming Mode	Press RLY1 and RLY2 for 1 second or timeout after 60 seconds	RX: ON PGM: OFF RLY1: OFF RLY2: OFF	 RLY1  RF  PGM  RLY2
LED Legend  Fast Flash Red  Slow Flash Red  Steady On Red  Steady Green  OFF				

Table 2: RF159 Keyfob Programming

Receiver LED Indicators

The RF159 2 Way Output Module includes RED and GREEN LED indicators which provide visual feedback during system operation. See Table 3 for information on the indicator colours and meanings.

LED Indicators			
Lable	LED Colour	Purpose	Meaning
RLY1	Red	RLY1 Operation / Programing	In programming mode with either a 50/50 blink or solid on as well as flashes on when the relay is operated.
RLY2	Red	RLY2 Operation / Programing	In programming mode with either a 50/50 blink or solid on as well as flashes on when the relay is operated.
RF	Green	Packet Receive / Transmit / Power	Indicates power on the module and receive/transmit data packets.
PGM	Red	Programing Mode	Blinks each time the system is polled by the control panel.

Table 3: RF159 Device LED's

Connection Diagram

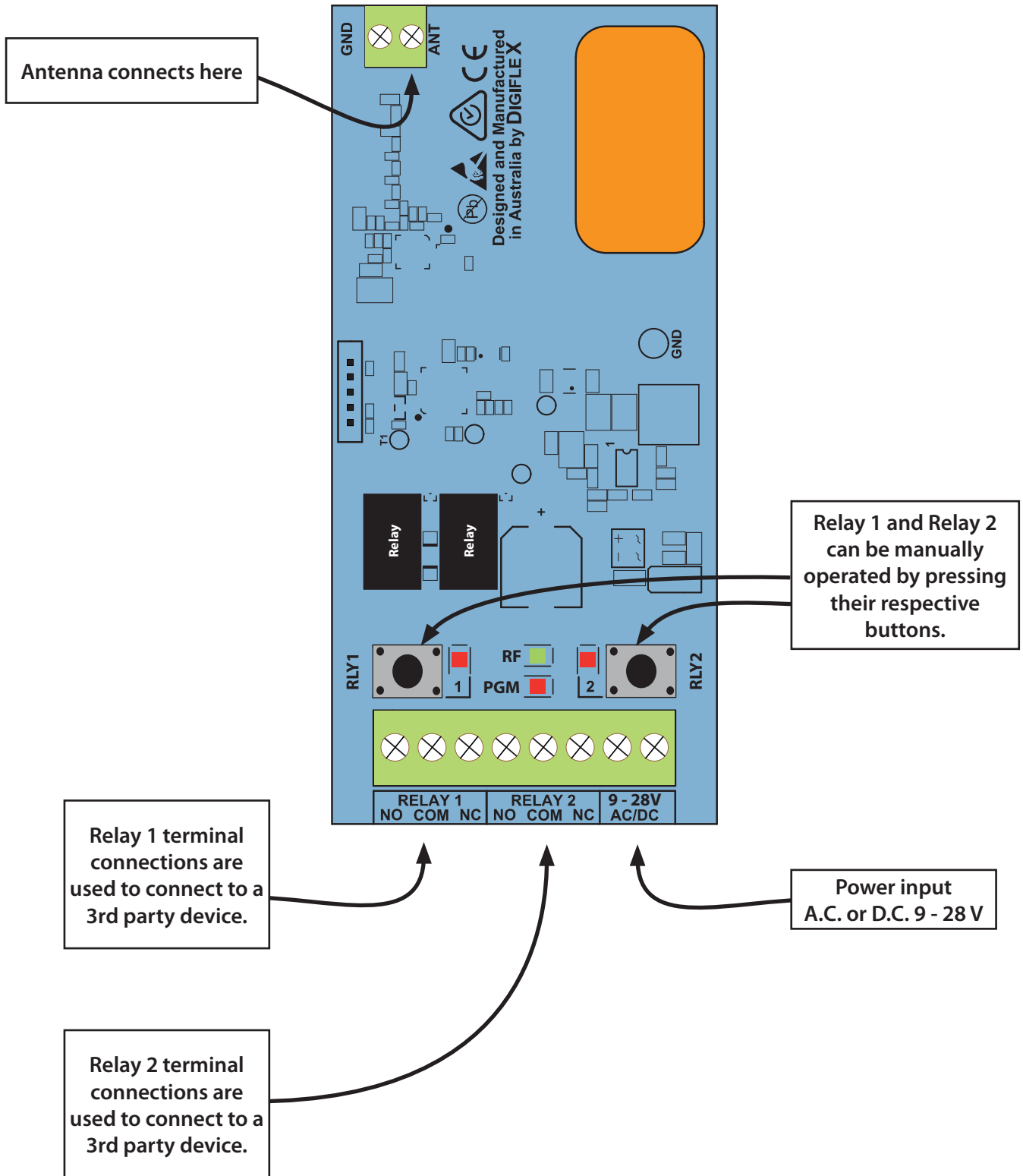
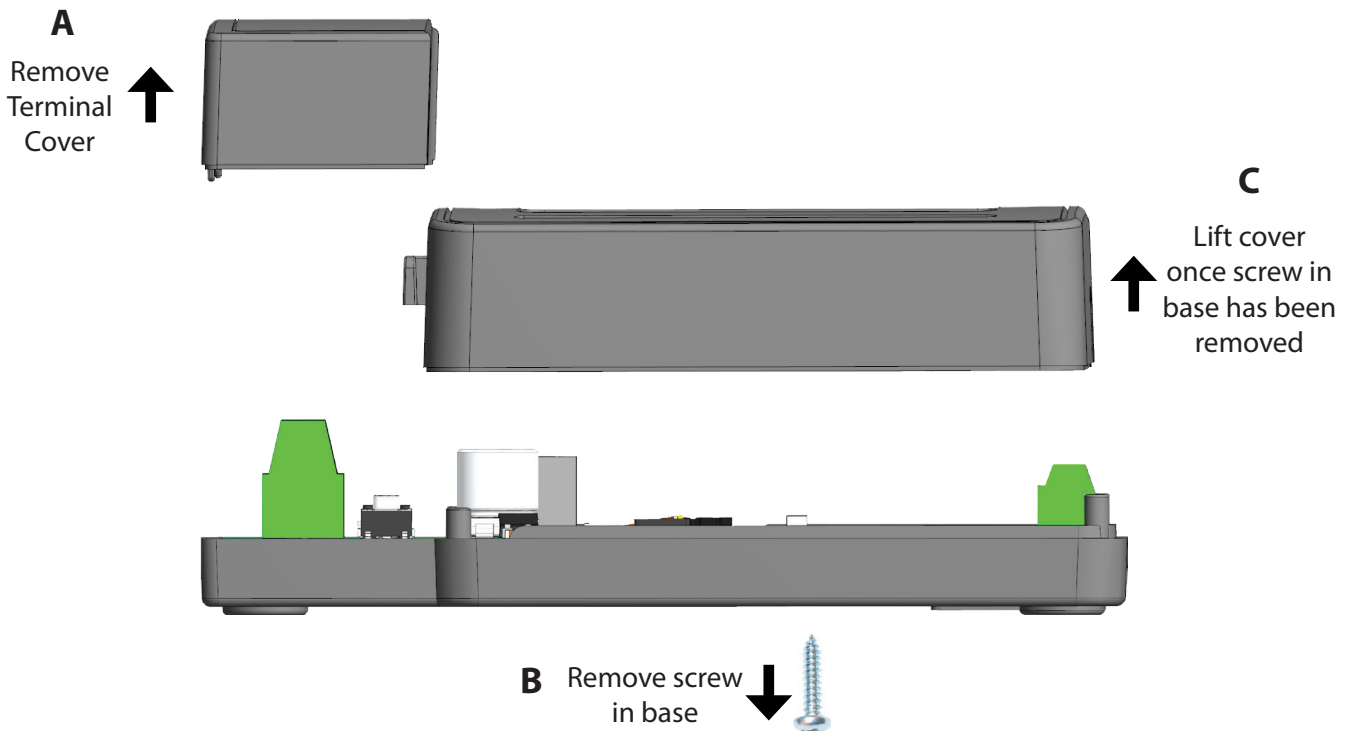

Figure 2: RF159 Connection Diagram

RF159 Housing

The RF159 is housed in 3 piece plastic enclosure comprising a base plate, top cover and a terminal cover. The top cover is fixed to the base using a Phillips head screw. The top cover needs to be removed to install the wire antenna. The terminal cover is a press fit allowing easy removal. Once the wiring and programming has been completed the cover should be reinstalled to help prevent the ingress of insects and other debris.



Wall Mounting

A wall mounting tab is located on the inside of the top cover should you wish to locate the unit on a wall or other structure. Once removed from the cover the tab slides and locks into the base plate as shown below.

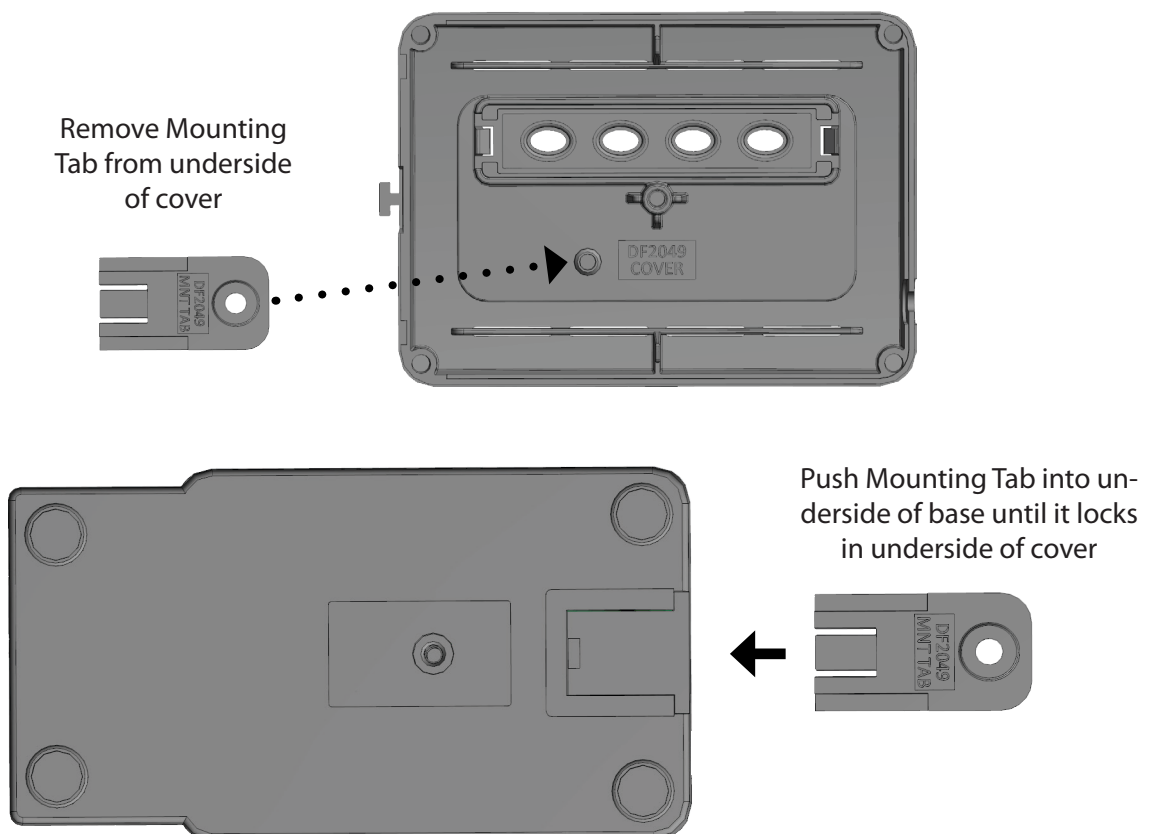

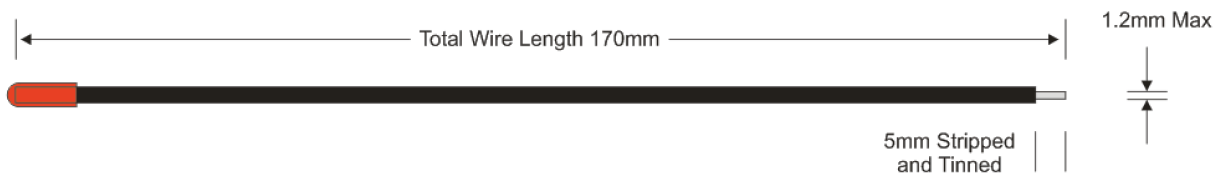
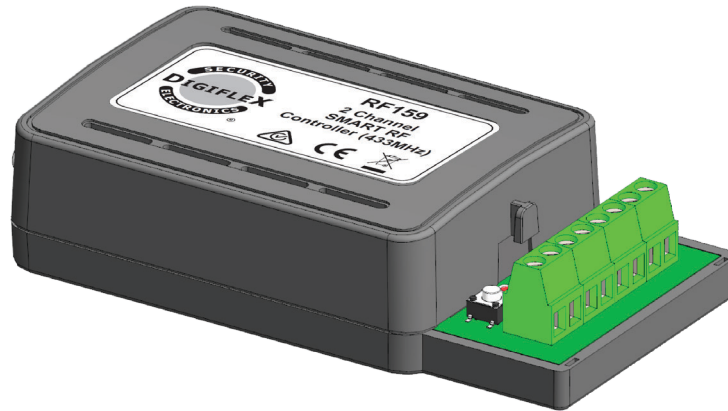
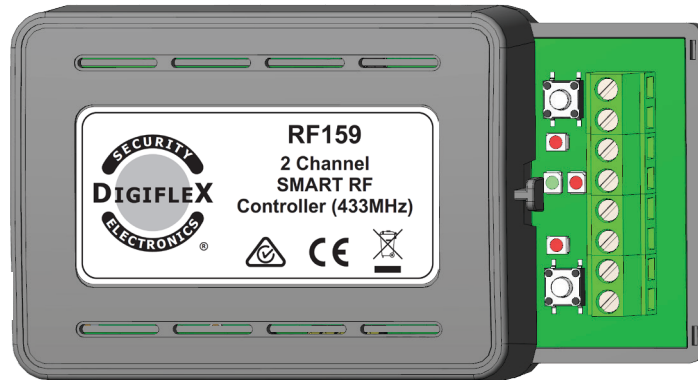

RF159 Specifications

Part Number: RF159 - 2 Channel SMART RF Controller - 433MHz

Operating Voltage: 9-28V A.C. / D.C. (70mA @ 12V D.C.)

Frequency: 433.42 MHz

Output Power -0.99 dBm

Dimensions: 114mm (W) 128mm (W with Mounting Tab), 62mm(D), 28mm(H)

Environment: 0° to 49°C Indoors

Fixing Method: Using mounting screws fix unit on a vertical surface in portrait orientation.

Relay Outputs: Contact Rating 1A @30V D.C.

Warranty: 3 years from date of manufacture (return to base).



In the interest of ongoing product development this document is subject to change without notice.



DIGIFLEX PTY LTD

18 Brumby Street
Seven Hills NSW 2147
AUSTRALIA

Phone: (+612) 97417000
Email: sales@digiflex.com.au
www.digiflex.com.au

Our Vision Is Your Peace Of Mind

