

1 | Overview

The B308 Octo-output Module is a supervised device that provides 8 programmable outputs (Form C relays) and connects to control panels through the SDI2 bus. Each output provides dry contact switching rated for a maximum of 1.0 A at 24 VDC. The outputs are accessed through on-board screw terminal connections. The address switches are used to set the module's SDI2 address. Control panel programming determines each output's response to specific events. The B308 receives serial data from the control panel and activates outputs in response to control panel conditions and settings. Outputs can be programmed for remote control from a control panel keypad.

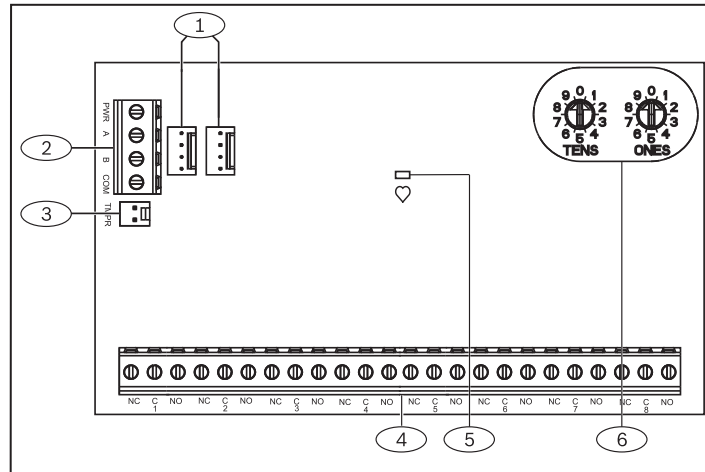

Figure 1.1: Board overview

Callout – Description

- 1 – SDI2 interconnect wiring connectors (to control panel or additional modules)
- 2 – SDI2 terminal strip (to control panel or additional modules)
- 3 – Tamper switch connector
- 4 – Terminal strip (outputs)
- 5 – Heartbeat LED (blue)
- 6 – Address switches

2 | SDI2 address settings

Two address switches determine the address for the B308 Octo-output Module. The control panel uses the address for communications. The address also determines the output numbers. Use a slotted screwdriver to set the two address switches.



NOTICE!

The module reads the address switch setting only during power up. If you change the switches after you apply power to the module, you must cycle the power to the module in order for the new setting to be enabled.

Set the address switches per the control panel configuration. If multiple B308 modules reside on the same system, each B308 module must have a unique address.

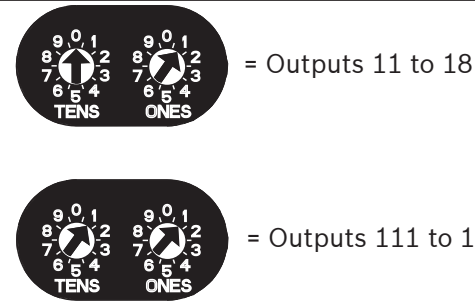

Figure 2.1: Address switches

The module's address switches provide a tens and ones value for the module's address. For single-digit address numbers 1 through 9, set the tens switch to 0 and the ones digit to the appropriate number. Figure 2.1 shows the address switches setting for addresses 1 and 11.

2.1 | Valid addresses and output numbers per control panel

Valid B308 addresses are dependent on the number of outputs allowed by a particular control panel.

Control panel	Valid B308 addresses	Corresponding output numbers
B5512	01 - 05	11 - 18, 21 - 28, 31 - 38, 41 - 48, 51 - 58
B4512	01 - 03	11 - 18, 21 - 28, 31 - 38
D9412GV4	01 - 12	11 - 18, 21 - 28, 31 - 38, 41 - 48, 51 - 58, 61 - 68, 71 - 78, 81 - 88, 91 - 98, 101 - 108, 111 - 118, 121 - 128
D7412GV4	01 - 06	11 - 18, 21 - 28, 31 - 38, 41 - 48, 51 - 58, 61 - 64
D7212GV4	01 - 02	11 - 18, 21 - 24

To determine the output numbers for each address, multiply the address number by 10 for the base number, and then use numbers 1 through 8 in the ones place for the output numbers.

Examples

For B308 address **01** the output numbers for the output devices are 11 through 18:

Terminal no	1	2	3	4	5	6	7	8
Output no	11	12	13	14	15	16	17	18

For B308 address **11** the output numbers for the output devices are 111 through 118:

Terminal no	1	2	3	4	5	6	7	8
Output no	111	112	113	114	115	116	117	118

3 | Installation

After you set the address switches for the proper address, install the module in the enclosure, and then wire it to the control panel.



NOTICE!

Remove all power (AC and battery) before making any connections. Failure to do so might result in personal injury and/or equipment damage.

3.1 | Mount the module in the enclosure

Mount the module into the enclosure's 3-hole mounting pattern using the supplied mounting screws and mounting bracket. Refer to Figure 3.1.

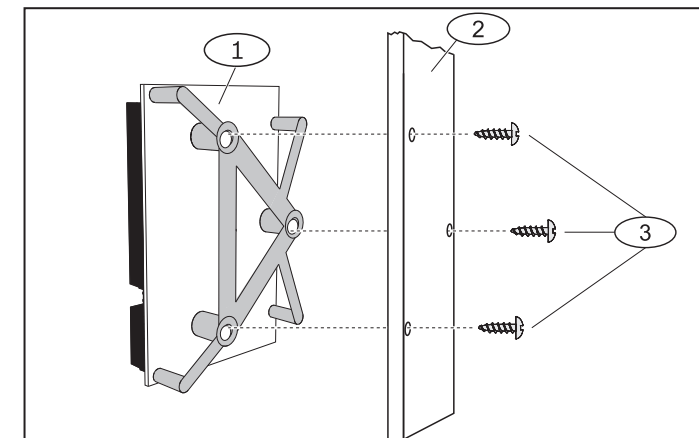

Figure 3.1: Mounting the module in the enclosure

Callout – Description

- 1 – Module with mounting bracket installed
- 2 – Enclosure
- 3 – Mounting screws (3)

3.2 | Mount and wire the tamper switch

You can connect an optional enclosure door tamper switch for one module in an enclosure.

Installing the optional tamper switch:

1. Mount the ICP-EZTS Tamper Switch (P/N: F01U009269) into the enclosure's tamper switch mounting location. For complete instructions, refer to *EZTS Cover and Wall Tamper Switch Installation Guide* (P/N: F01U003734).
2. Plug the tamper switch wire onto the module's tamper switch connector. Refer to Figure 1.1.

3.2 | Wire to the control panel

When you wire the module to a control panel, you can use either the module's terminal strip labeled with PWR, A, B, and COM, or the module's interconnect wiring connectors (wire included). Interconnect wiring parallels the PWR, A, B, and COM terminals on the terminal strip. Figure 1.1 indicates the location of both the terminal strip and the interconnect connectors on the module. Refer to Figures 3.2, 3.3, and 3.4.



NOTICE!

Use either the terminal strip wiring **or** interconnect wiring connector to the control panel. Do not use both. When connecting multiple modules, you can combine terminal strip and interconnect wiring connectors in series.

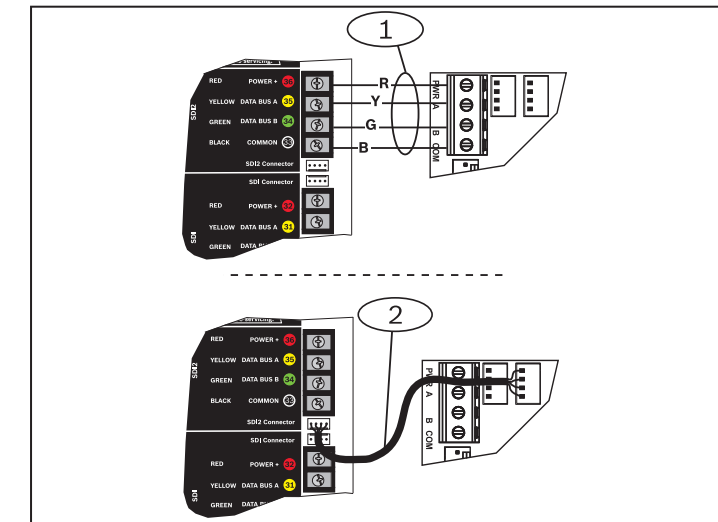

Figure 3.2: Using terminal strip or interconnect cable wiring (D9412GV4 shown)

Callout – Description

- 1 – Terminal strip wiring (SDI2)
- 2 – Interconnect cable (P/N: F01U079745) (included)

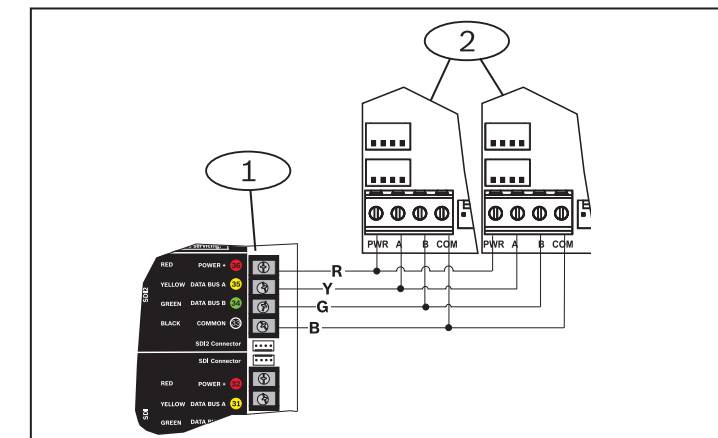

Figure 3.3: Installing multiple modules using the SDI2 terminal strip (D9412GV4 shown)

Callout – Description

- 1 – Bosch control panel
- 2 – B308 modules

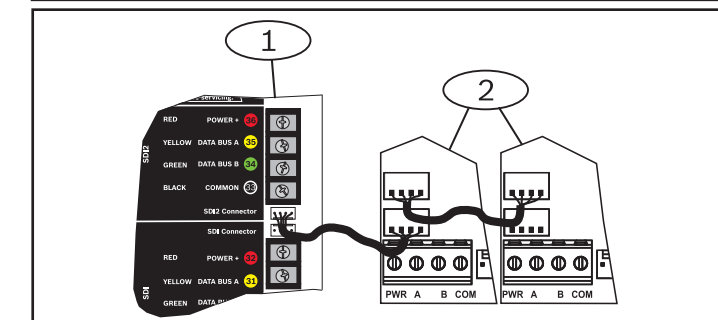

Figure 3.4: Installing multiple modules using the SDI2 interconnect wiring connector (D9412GV4 shown)

Callout – Description

- 1 – Bosch control panel
- 2 – B308 modules

3.4 | Relay output wiring

Each output provides a NO and a NC output. The NO, C (COMMON), and NC terminals are available in each terminal or connection output position. The silkscreen on the edge of the B308 circuit board clearly identifies the function of each terminal and the relay output number.

The middle terminal of each output position is the COMMON of the output and is labeled C. When the output is in an inactive state, the NC (Normally Closed) terminal has continuity with the C terminal. When the output is in an active (energized) state, the NO (Normally Open) has continuity with the C terminal.



NOTICE!

Do not exceed relay contact ratings of 1.0 A, 24 VDC, resistive load.

4 | LED descriptions

The module includes one blue heartbeat LED to indicate that the module has power and to indicate the module's current state. Refer to *Table 4.1*.



Flash Pattern	Function
Flashes once every 1 sec 	Normal state: Indicates normal operation state.
3 quick flashes every 1 sec 	Communication error state: Indicates (the module is in a “no communication state”) resulting in an SDI2 communication error.
ON Steady 	LED trouble state: Module is not powered (for OFF Steady only), or some other trouble condition prohibits the module from controlling the heartbeat LED.
OFF Steady 	

Table 4.1: LED descriptions

5 | Show the firmware version

To show the firmware version using an LED flash pattern:

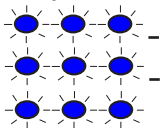
- If the optional tamper switch is installed: With the enclosure door open, activate the tamper switch (push and release the switch).
- If the optional tamper switch is NOT installed: Momentarily short the tamper pins.

Refer to *Figure 5.1* for an example of flash patterns.

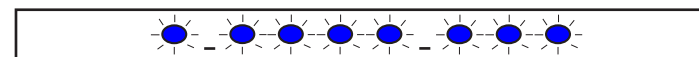

Figure 5.1: Firmware LED flash patterns

When the tamper switch is activated (closed to open), the heartbeat LED stays OFF for 3 sec before indicating the firmware version. The LED pulses the major, minor, and micro digits of the firmware version, with a 1 sec pause after each digit.

Flashing patterns do not start until the tamper is open (short is removed). In the following example, the version 1.4.3 shows as LED flashes:

[3 sec pause] * _****_*** [3 sec pause, then normal operation].

6 | Certifications

Region	
US	UL 365 - Police Station Connected Burglar Alarm Units and Systems
	UL 609 - Local Burglar Alarm Units and Systems
	UL 985 - Household Fire Warning System Units
	UL 1076 - Proprietary Burglar Alarm Units and Systems
	UL 1023 - Household Burglar-Alarm System Units
	UL 1610 - Central-Station Burglar-Alarm Units
	UL 864 - Control Units and Accessories for Fire Alarm Systems
	CSFM - California Office of The State Fire Marshal
	FCC Part 15 Class B FM Approval 3010
Canada	CAN/ULC-S304 Central and Monitoring Station Burglar Alarm Units
	ULC/ORD-C1023 Household Burglar Alarm System Units
	CAN/ULC-S303 Local Burglar Alarm Units and Systems
	ULC/ORD-C1076 Proprietary Burglar Alarm Units and Systems

7 | Specifications

Dimensions	2.9 in x 5.0 in x 0.6 in (73.5 mm x 127 mm x 15.25 mm)
Voltage (operating)	12 V nominal
Current (maximum)	150 mA (22 mA for digital section + 16 mA per energized relay)
Operating temperature	+32°F to +122°F (0°C to +50°C)
Relative humidity	5% to 93% at +90°C (+32°C) non-condensing
Relay outputs	Dry contacts rated for .001 to 1.0 A at 5 to 24 VDC (resistive load).
Terminal wire size	12 AWG to 22 AWG (2 mm to 0.65 mm)
SDI2 wiring	Maximum distance - Wire size (Unshielded wire only): 400 ft (122 m) - 22 AWG (0.65 mm) 1000 ft (305 m) - 18 AWG (1.02 mm)
Compatibility	B5512 (Up to 5 modules) B4512 (Up to 3 modules) D9412GV4 (Up to 12 modules) D7412GV4 (Up to 6 modules) D7212GV4 (Up to 2 modules)

Copyright

This document is the intellectual property of Bosch Security Systems, Inc. and is protected by copyright. All rights reserved.

Trademarks

All hardware and software product names used in this document are likely to be registered trademarks and must be treated accordingly.

Bosch Security Systems, Inc. product manufacturing dates

Use the serial number located on the product label and refer to the Bosch Security Systems, Inc. website at <http://www.boschsecurity.com/datecodes/>.

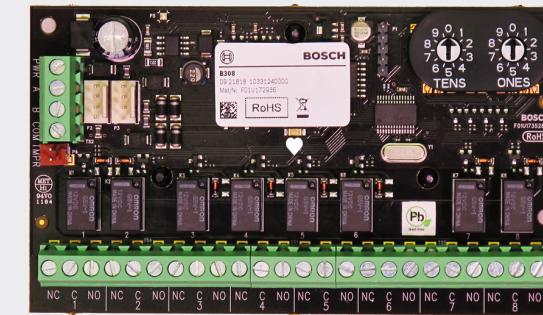

Octo-output Module B308



en Installation Guide

Bosch Security Systems, Inc.
130 Perinton Parkway
Fairport, NY 14450
USA
www.boschsecurity.com

