

### Statement:

The GK-350 series surface mount electric strikes are designed for use with night latch locks (without deadbolt) having up to 12 mm keeper depth for in-swinging doors.

The units are design for use with most hollow metal frames, aluminum frames and wood frames. Stainless steel plate ensures strength and long life.

### Specifications:

- Power Input: 12 V DC (24V DC available by special order)
- Voltage Tolerance:  $\pm 15\%$
- Current Draw: 0.25 A@12 VDC; 0.15 A@24 VDC (at temperature 20°C)
- Operating Temperature: -10~45°C
- Humidity: 0~95% non-condensing.
- Lock's surface Temperature (when the power is on):  $\leq$  current temperature +20°C
- 2000 LBS jaw strength pull testing.
- Tested to 1,000,000 cycles.
- Weight (Approx.) : 330 g

### Version Changeable

Field-reversible (by changing position of screws) on site for Fail-safe (Power to Lock) or Fail-secure (Power to Open) in 10 seconds.

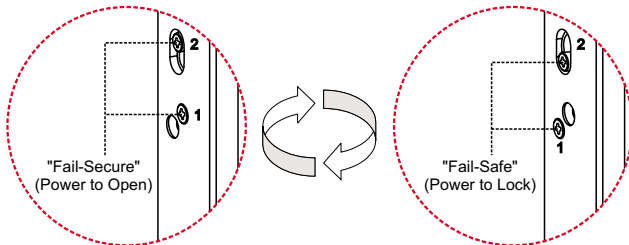

### Long life solenoids

Strikes are powered by a solenoid, not a buzzer coil. Special designed solenoid for strength and long life operating lifetime with guaranteed 1,000,000 operations.

### Warranty:

GEM Electric Strikes are warranted against defects in material and workmanship while used in normal service for a period of 3 years from the date of sale to the original customer.

### Disclaimer:

The information and specifications printed in this manual are current at the time of publication. The GEM policy is one of continual development and improvement; therefore GEM reserves the right to change specifications without notice.

**GIANNI INDUSTRIES, INC.**



GK-350

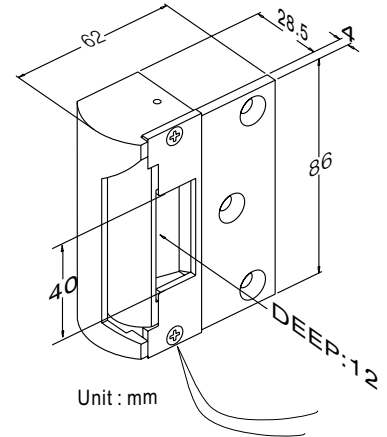

### Hollow Frames Surface Mount Installation

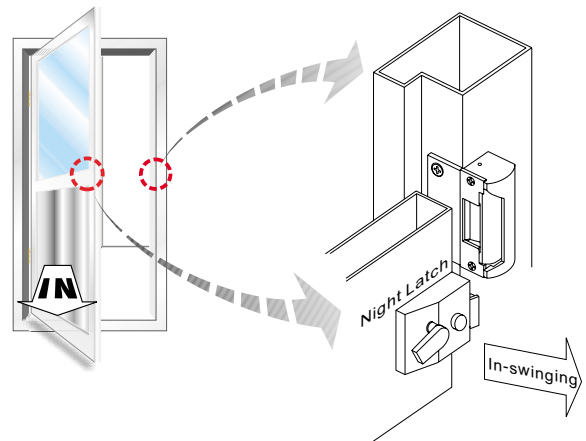

### Wood Frames Surface Mount Installation

