

## TVI 5MP/AHD 5MP/CVI 4MP CAMERA

# C-TVI5MPS800



### Key Features:

- 1/2.9" SONY Starvis CMOS Sensor
- Mode 2MP 1080P/ 960H
- 3DNR

## WARRANTY

|                  |                    |                |                                 |  |
|------------------|--------------------|----------------|---------------------------------|--|
|                  |                    |                | <b>Warranty Period: 2 years</b> |  |
| Product          | GIMBAL DOME CAMERA | Model          | C-TVI5MPS800                    |  |
| Purchase Address |                    | Serial No.     |                                 |  |
| Dealer           |                    | Customer       |                                 |  |
|                  |                    | Representative |                                 |  |

► Please contact purchasing office or service center when you find any damage or problem with this product.

► The warranty period is 2 years from Invoice date.

### ◆ A/S without cost ◆

| Within Warranty Period                              |                   | Warranty details |                |
|---|-------------------|------------------|----------------|
|   |                   | Within warranty  | After Warranty |
| When damages occurred in normal working environment | Repair or Replace | Product          |                |
|   |                   | A/S without cost |                |
|   |                   | Product exchange |                |

### ◆ A/S with cost ◆

| Damage by customer's negligence      |  | Warranty details |
|--------------------------------------|--|------------------|
| chargeable case even within warranty | 1. Damage by customer's careless handling<br>2. Damage by natural disaster (Fire, Flood, etc.)<br>3. Damage by not keeping the cautions and instructions on manual or adapter.<br>4. Damage by not using appointed power(frequency, voltage) or adapter.<br>5. Damage by disassemble or cleaning by customer<br>6. Damage by repairment by a person excepting the dealer | A/S with cost    |

## SPECIFICATION

| DESCRIPTION           | PAL  |
|-----------------------|--|
| Image Sensor          | 1/2.9" SONY 2.1MP Starvis Back-illuminated CMOS Sensor |
| Image Resolution      | 5MP  |
| Effective Pixels      | 5M:2592*1944 4M:2560*1440                              |
| Video Output          | TVI/AHD/CVI/960H                                       |
| Electronic Shutter    | 1/25s~1/50,000s, 1/30s~1/60,000s                       |
| S/N Ratio             | ≥50dB  |
| Scanning System       | Progressive Scan                                       |
| Focus Length          | 3.6mm  |
| Focus Control         | Fixed  |
| Lens Type             | Fixed  |
| Auto Iris Support     | NO   |
| OSD Menu Language     | YES  |
| White Balance         | AUTO / MANUAL  |
| Gain Control          | AUTO   |
| Noise Reduction       | 3DNR   |
| Picture Adjustment    | YES  |
| WDR                   | YES  |
| OSD Support           | YES  |
| UTC                   | YES  |
| Housing               | Plastic  |
| Bracket               | NO   |
| Dual Voltage          | NO   |
| IR Cut Filter         | YES  |
| Heater                | NO   |
| Audio                 | /  |
| Operation Temperature | -10℃ ~ +50℃ RH95% Max                                  |
| Storage Temperature   | -20℃ ~ +60℃ RH95% Max                                  |
| Power Source          | DC12V±10%, 250mA                                       |
| Dimension             | ∅ 119 x 56(H) mm                                       |
| Weight                | 350g   |

## DIMENSION

### C-TVI5MPS800

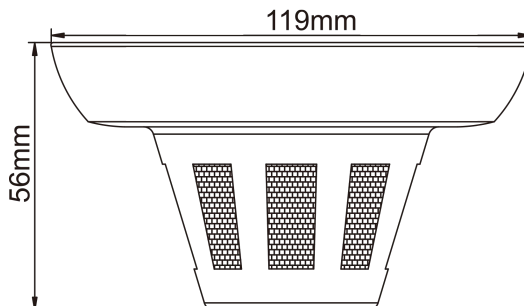

## CONNECTING OF CAMERA

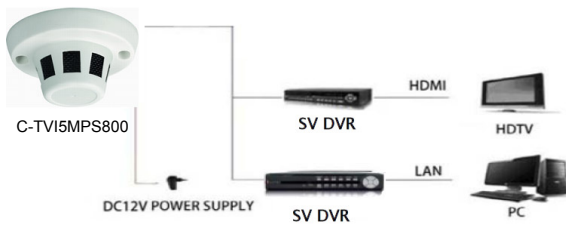

1. No Picture after providing power. May be the power supply voltage abnormality, please check the power supply voltage and pole whether exactitude. Please check all the connecting cable and monitors whether be connected correctly or not.

2. The picture level direction have flowing interference ripples. May be caused by the power supply AC ripples, it need filter the wave of the power supply. Check the monitor and peripheral equipments used

3. The picture background color changes continuously. The fluorescent lamp's electromagnetic field cause color roll. This is proper phenomenon of the cameras. Reduce the fluorescent lamp numbers or increase the distance between the camera and the fluorescent lamps can improve it. Use power supply external sync. camera can solve it.

4. The picture smear too mass . The power supply's voltage unstable. Connecting cables not connect correctly or have high impedance.

## CAUTION IN INSTALLATION

- ♣ Do not install the camera opposite of the sun so that it be avoided direct light.
- ♣ Be careful not to drop this camera and not to impact on it. CCTV camera is a precision device.
- ♣ Do not pull the cable. If you pull the cable, it will make electrical problems such as disconnection.
- ♣ The camera should be worked within a range of the allowable temperature that refers to specification.
- ♣ Do not try to fix even if the camera does not work.
- ♣ Installation this camera at safety place where is no water, If the camera has some problems with water accidently. You have to contact A/S centre that sold the camera to you.
- ♣ If you would like to relocate the already installed product, be sure to turn off the power and then move or reinstall it.
- ♣ Please contact the nearest A/S centre if you find out any Problems. Please do not ignore any small problems they can become a big problem.

## Feature Summary

### \* Sensor (CMOS)

1/2.9" SONY Starvis CMOS Sensor

### \* Auto Gain Control (AGC)

Built-in auto gain control (AGC) circuit. The color camera can get high definition picture in low Lux condition.

### \* Scanning Mode

NTSC or PAL mode.

### \* Auto Electronic Shutter (AES)

Built-in auto electronic shutter function.

The color camera's AES speed can reach 1/100,000s.

### \* Gama Characteristic

Camera Gama characteristic is 0.45.

### \* Scanning Mode

NTSC or PAL mode.

### \* Switch the output signal by OSD button

Press "left" key after 5 seconds then release : CVBS

Press "right" key after 5 seconds then release : TVI

Press "up" key after 5 seconds then release : AHD

Press "down" key after 5 seconds then release : CVI

## CAUTION

**Warning** To prevent fire or shock hazarded. Do not expose the unit rain to rain or moisture.

 The symbol is intended to alert the user to the presence of important important operating and maintenance (servicing) Instructions in the literature accompanying the appliance.

 The symbol is intended to alert the user to the presence of uninsulated 'dangerous voltage' within the product's enclosure that may be of sufficient Magnitude to constitute a risk of electric shock to persons.

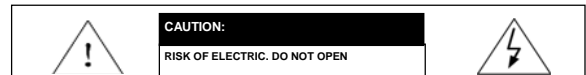

**CAUTION: TO REDUCE THE RISK OF ELECTRIC SHOCK, DO NOT REMOVE COVER OR BACK NO USER SERVICEABLE PARTS INSIDE. REFER SERVICING TO**

**CAUTION: To prevent electric shocks and risk of fire hazards, do NOT use other than specified power source.**



### Note:

- Please note the camera's operating temperature and its using environment requirement. Avoid using the camera at too high or too low temperatures. The operating temperature is -30~+60°C. (Recommendatory operating temperature is -10~+50°C.)
- Never make the camera face the sun or bright object. Otherwise, it will damage the CMOS.