

PRINT MAY BE REDUCED - DO NOT SCALE.

Item #	Part Name	Part No.	Qty
1	Lift Guide Rail(9003) Complete Assembly	DUO-BUN0BUN-001	1
2	Trio Universal Car Body Assembly Half Door	53102-00069	1
3	Trio Floor Insert	35108-00012	1
4	Trio Floor Insert Flange	35108-00013	1
5	Trio Hoist S1	TRI-1A0BN5N-001	1
6	Trio Floor Insert Shaft Lid Assembly	53102-00076	1

Rev	Description	By	Date
A	New Drawing	Wagon	2017/5/20

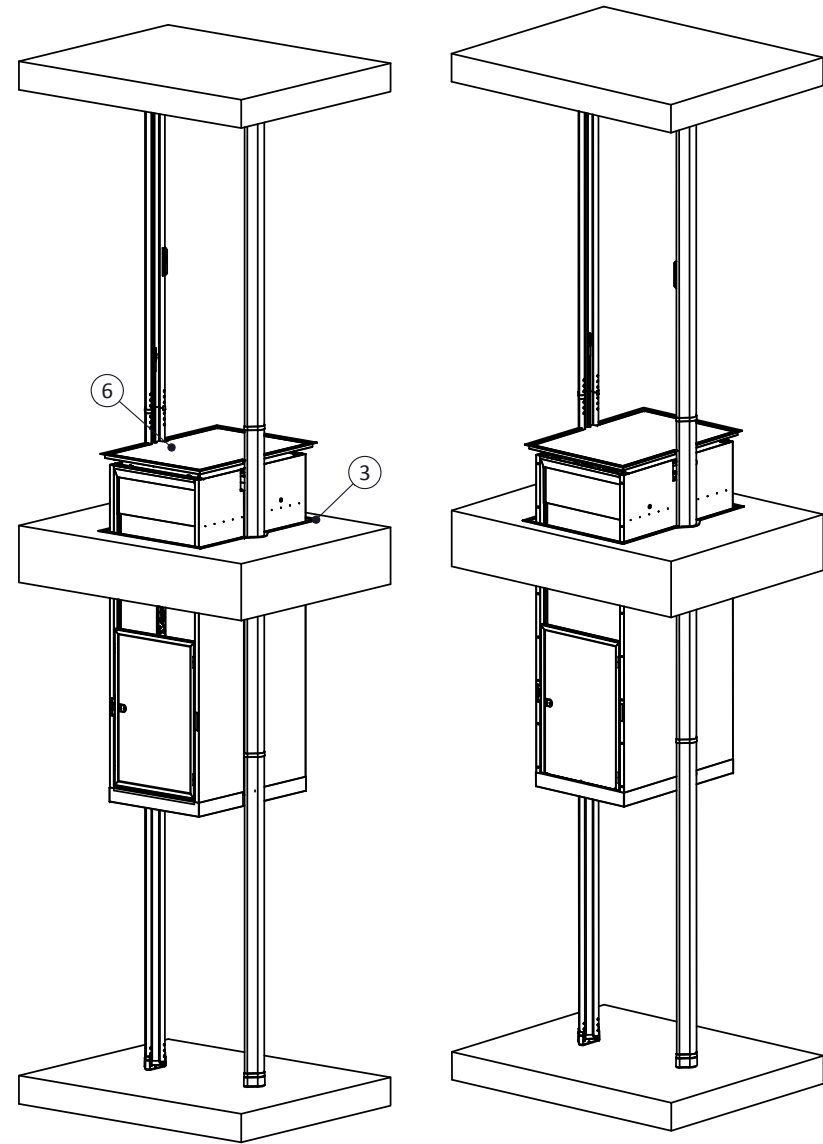
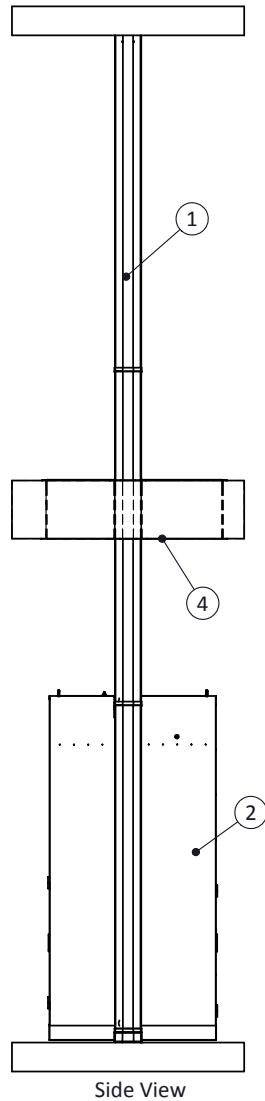
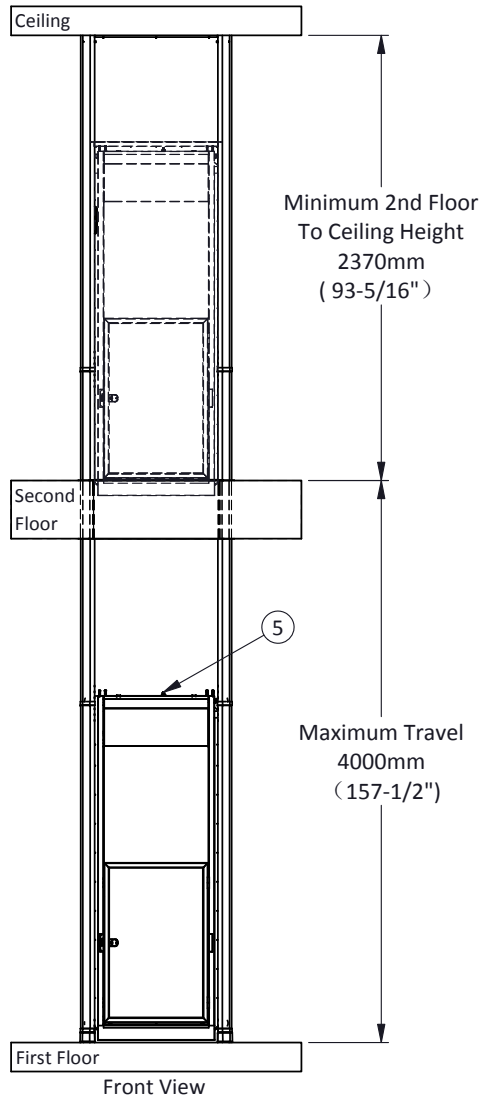

Approved for Manufacture

By: (Sign)
Name:.....

GENERAL TOLERANCES (Unless Noted Otherwise):

0-30mm	±0.1	30-120mm	±0.2
120-400mm	±0.3	400-1000mm	±0.5
1000-2000mm	±1.0	>2000mm	±1.5
Angular	±0.25 Deg.		

Break ALL sharp corners and remove burrs or swarf.



Drawn		Date		TITLE	
Wagon Wang		2017/5/20		Trio Thru Lift Complete	
DIMENSIONS IN MM UNLESS OTHERWISE NOTED THIRD ANGLE PROJECTION - AS 1100				A4 Dwg No TTC-CESAU101 SCALE:	
				PAGE 1 OF 15	

PRINT MAY BE REDUCED - DO NOT SCALE.

Rev	Description	By	Date
A	New Drawing	Wagon	2017/05/25

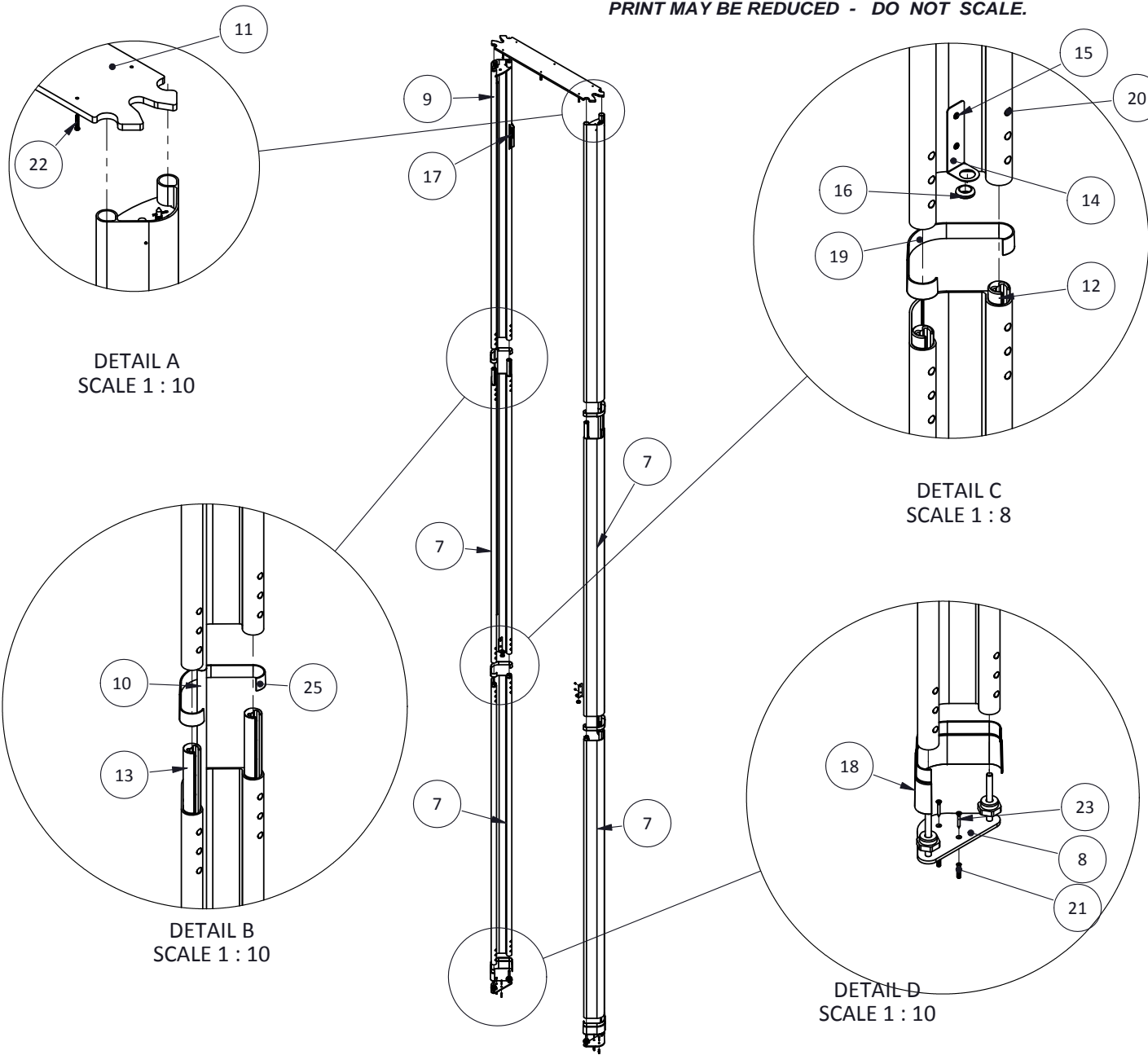

Item #	Part Name	Part No.	Qty
7	Guide Rail Uni 2.3m V.B	25104-00063	4
8	Guide Base Plate Assembly	55102-00003	2
9	Guide Top Rail(9003) 2.3m Assembly	55102-00035	2
10	Lift Gripper Rod Assembly	55102-00020	2
11	Guide Top Spacer V.E	28103-00003	1
12	Guide Rail Short Joiner Assembly	55102-00017	4
13	Guide Rail Long Joiner Assembly	55102-00016	4
14	Gripper Rod Bottom Bracket V.A	35104-00001	2
15	Big Pan Head Blind Rivet $\Phi 9 \times \Phi 3.2 \times 7 \text{mm}$	30108-00002	4
16	Cable Bush 16mm White	10908-00001	2
17	Limit Ramp Assembly	55102-00004	2
18	Guide Rail Base Cover	20101-00018	2
19	Guide rail joint cover	20101-00019	4
20	Hole Plug 8mm	20101-00015	60
21	Anchor 6x30mm	30110-00001	4
22	SS Philips Pan Head Self-tapping screw 4.2x30mm	30101-80727	6
23	SS Philips Csk Head Self-tapping Screw 3.9x32mm	35102-00001	4

DETAIL A
SCALE 1 : 10

DETAIL C
SCALE 1 : 8

DETAIL B
SCALE 1 : 10

DETAIL D
SCALE 1 : 10

Approved for Manufacture

By: (Sign)
Name:.....

GENERAL TOLERANCES (Unless Noted Otherwise):

0-30mm	±0.1	30-120mm	±0.2
120-400mm	±0.3	400-1000mm	±0.5
1000-2000mm	±1.0	>2000mm	±1.5
Angular	±0.25 Deg.		

Break ALL sharp corners and remove burrs or swarf.



TITLE		Guide Rail Assembly	
Drawn Wagon Wang	Date 2017/05/25	A4	Dwg No LDU-AUN4AUN-002
DIMENSIONS IN MM UNLESS OTHERWISE NOTED THIRD ANGLE PROJECTION - AS 1100			
SCALE:			

PRINT MAY BE REDUCED - DO NOT SCALE.

Rev	Description	By	Date
A	New Drawing	Wagon	2017/07/08

Item #	Part Name	Part No.	Qty
24	Trio Thru Universal Entrance Style Back LH Assembly	53102-00147	1
25	DTC Side Channel LH	35102-00046	1
26	Trio Thru Universal Entrance Style LH Assembly	53102-00145	1
27	Trio Lift Half Door Complete Assembly	53102-00025	2
28	Electric Strike Door Lock	10451-00001	2
29	Trio Front Electric Cover Assy	53102-00173	1
30	Trio Thru Universal Entrance Style RH Assembly	53102-00146	1
31	Lift Side Channel RH	35102-00022	1
32	Trio Thru Universal Entrance Style Back RH Assembly	53102-00148	1
33	Trio Back Electrical Cover Kit	53102-00065	1
34	Trio Guide Roller Assembly	50102-00029	1 Pair

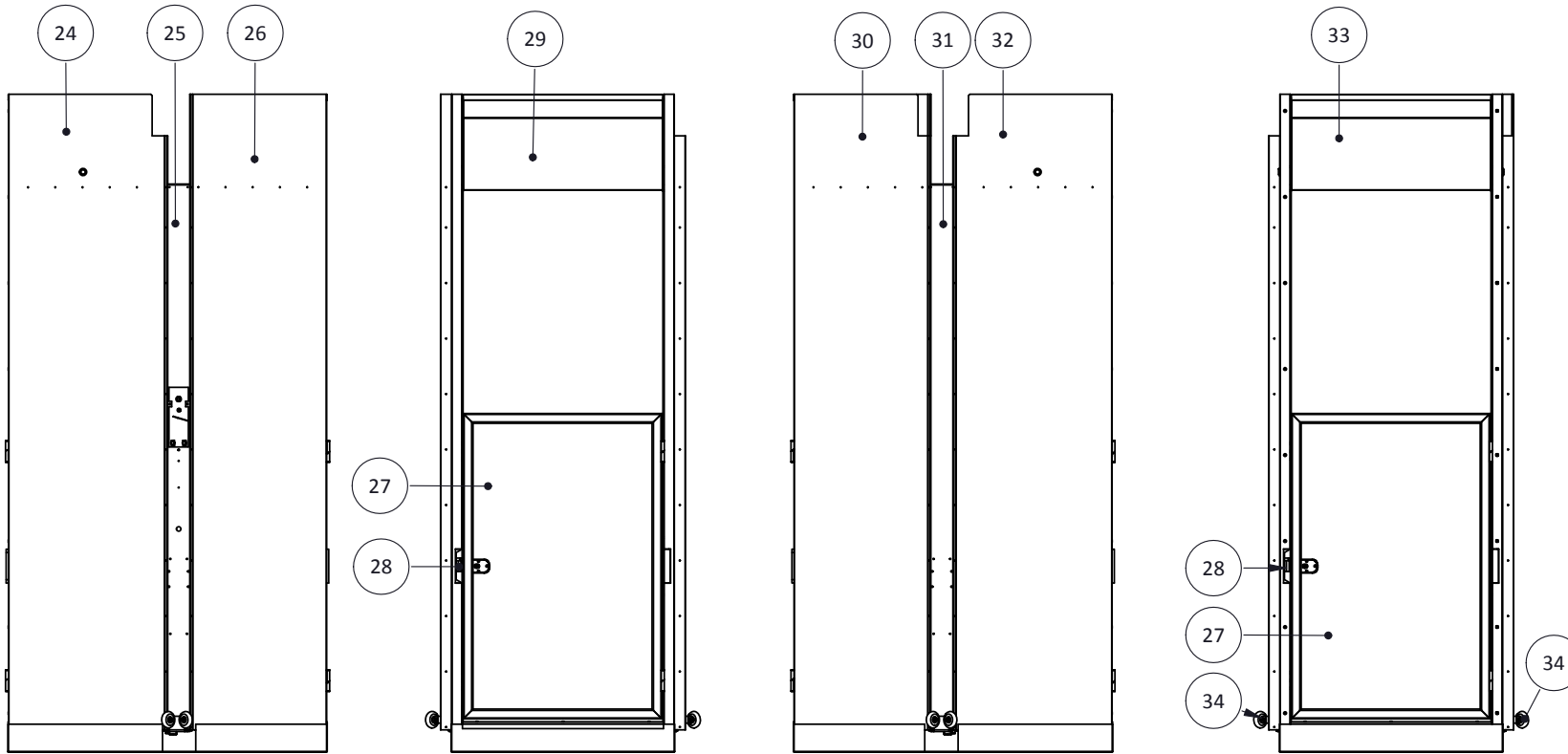

Approved for Manufacture

By: (Sign)
Name:.....

GENERAL TOLERANCES (Unless Noted Otherwise):

0-30mm	±0.1	30-120mm	±0.2
120-400mm	±0.3	400-1000mm	±0.5
1000-2000mm	±1.0	>2000mm	±1.5
Angular	±0.25 Deg.		

Break ALL sharp corners and remove burrs or swarf.



Drawn Wagon Wang		Date 2017/07/08		TITLE Trio Universal Car Body Assembly Half Door(Trio - Thru)	
 THIRD ANGLE PROJECTION - AS 1100		DIMENSIONS IN MM UNLESS OTHERWISE NOTED		Dwg No 53102-00069 SCALE:	
A4				PAGE 3 OF 15	

PRINT MAY BE REDUCED - DO NOT SCALE.

Rev	Description	By	Date
A	New Drawing	Wagon	2017/07/08

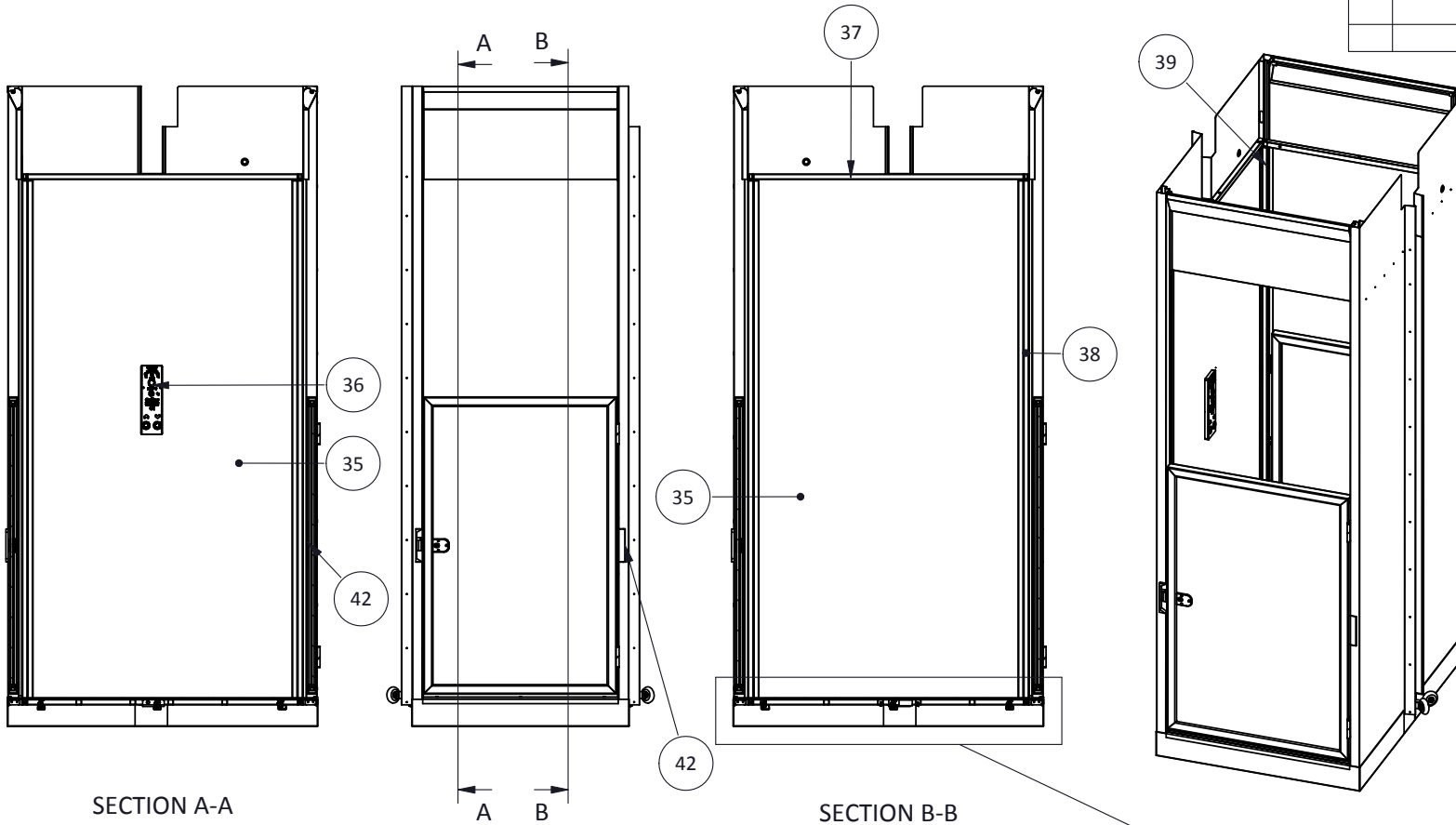

Item #	Part Name	Part No.	Qty
24	Trio Thru Universal Entrance Style Back LH Assembly	53102-00147	1
25	DTC Side Channel LH	35102-00046	1
26	Trio Thru Universal Entrance Style LH Assembly	53102-00145	1
27	Trio Lift Half Door Complete Assembly	53102-00025	1
28	Electric Strike Door Lock	10451-00001	1
29	Trio Front Electric Cover Assy	53102-00173	1
30	Trio Thru Universal Entrance Style RH Assembly	53102-00146	1
31	Lift Side Channel RH	35102-00022	1
32	Trio Thru Universal Entrance Style Back RH Assembly	53102-00148	1
33	Trio Back Electrical Cover Kit	53102-00065	1
34	Trio Guide Roller Assembly	50102-00029	1 Pair
35	Trio Thru Car Body Wall Carpet HG	28106-00073	2
36	Trio COP Assembly	53104-00003	1
37	Trio Thru Car Ceiling Hoop	35108-00004	1
38	Lift Light Curtains	10204-00004	2 Set
39	Trio Column	35108-00006	4
40	Trio Thru Floor Panel Assembly	53102-00042	1
41	Trio Thru Safety Pan Assembly	50102-00018	1
42	Trio Lock Cover Plate	35113-00008	2

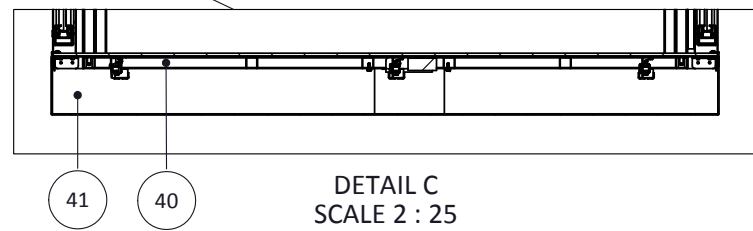

SECTION A-A

SECTION B-B

DETAIL C
SCALE 2 : 25

Approved for Manufacture	GENERAL TOLERANCES (Unless Noted Otherwise):
By: (Sign)	0-30mm ±0.1 30-120mm ±0.2
Name:.....	120-400mm ±0.3 400-1000mm ±0.5
	1000-2000mm ±1.0 >2000mm ±1.5
	Angular ±0.25 Deg.
	Break ALL sharp corners and remove burrs or swarf.



Drawn Wagon Wang		Date 2017/07/08	TITLE Trio Universal Car Body Assembly Half Door(Trio - Thru)	
 THIRD ANGLE PROJECTION - AS 1100		DIMENSIONS IN MM UNLESS OTHERWISE NOTED		Dwg No 53102-00069 SCALE:
A4			PAGE 4 OF 15	

PRINT MAY BE REDUCED - DO NOT SCALE.

Rev	Description	By	Date
A	New Drawing	Wagon	2017/12/14

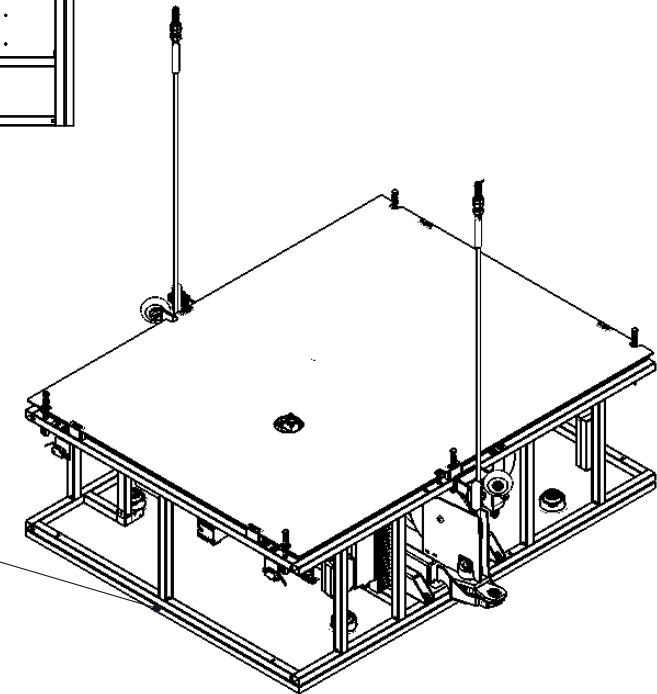
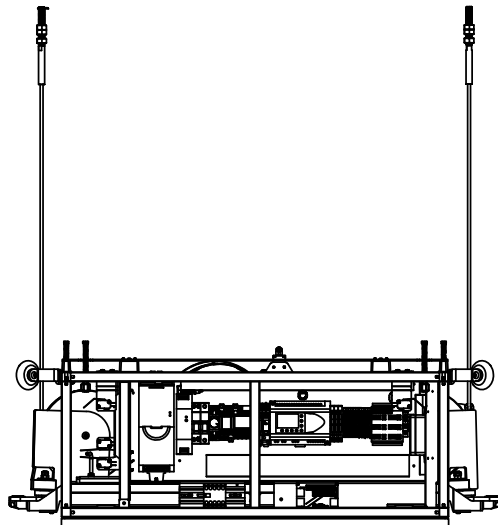
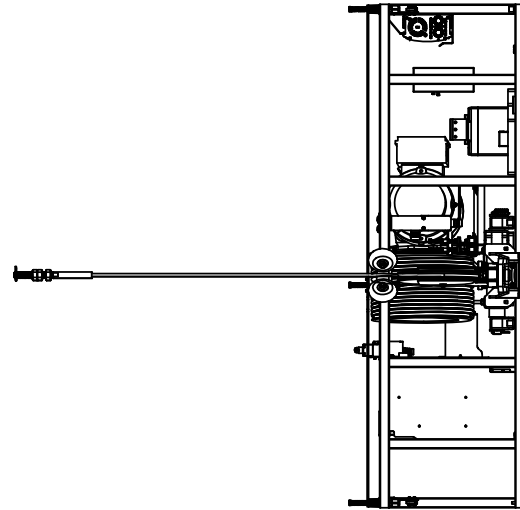
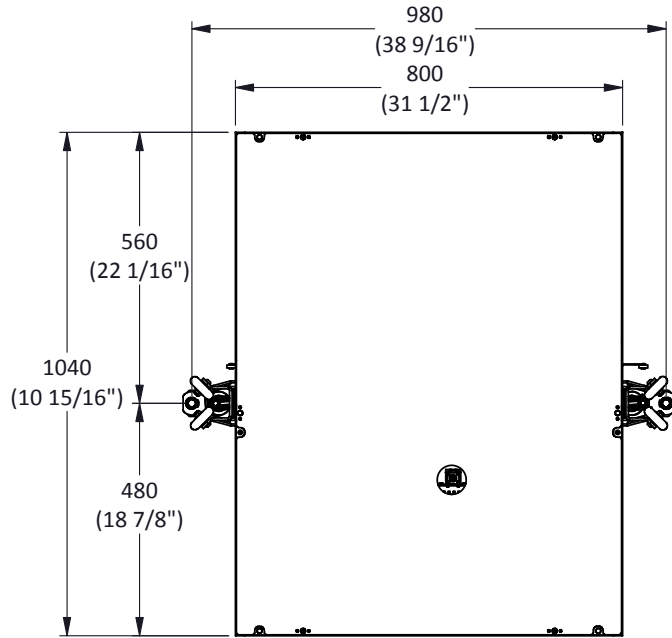

Trio Thru Ceiling Protection Panel
P/N:28102-00021
(Before install take off it)

Approved for Manufacture

By: (Sign)
Name:.....

GENERAL TOLERANCES (Unless Noted Otherwise):

0-30mm	±0.1	30-120mm	±0.2
120-400mm	±0.3	400-1000mm	±0.5
1000-2000mm	±1.0	>2000mm	±1.5
	Angular		±0.25 Deg.

Break ALL sharp corners and remove burrs or swarf.

Drawn		Date		TITLE	
Wagon Wang		2017/12/14		Trio Hoist Assembly	
 THIRD ANGLE PROJECTION - AS 1100		DIMENSIONS IN MM UNLESS OTHERWISE NOTED		A4	Dwg No TRI-1A0BN5N-001 SCALE:

PRINT MAY BE REDUCED - DO NOT SCALE.

Item #	Part Name	Part No.	Qty
43	Duo Guide Roller Assembly	50102-00020	1 Pair
44	CTEK Battery Charger With Bracket Assembly	50104-00022	1
45	Lift Wire Rope 6m Assembly	50102-00007	1 Set
46	LED Light 3X1W	10303-00006	4
47	Trio Electrical Panel Electrical Assembly	50102-00062	1
48	Trio Thru Motor Cover Plate Assembly	50102-00026	1
49	Trio Thru Hoist Mechanical Assembly	50101-00004	1
50	Overload Striker Plate Assembly	50104-00029	1
51	Overload Switch Bracket Assembly	50104-00009	1
52	Trio Battery Retainer Bracket Assembly	50104-00059	1
53	Main Switch	10305-00003	1
54	Lead Acid Battery 12V	50104-00052	1
55	Power Inverter Assembly	50104-00051	1
56	Rear Light Curtain Controller Assembly	50104-00056	1
57	Nord GearBox Motor 550W N2 Assembly	50102-00076	1

Rev	Description	By	Date
A	New Drawing	Wagon	2017/12/14

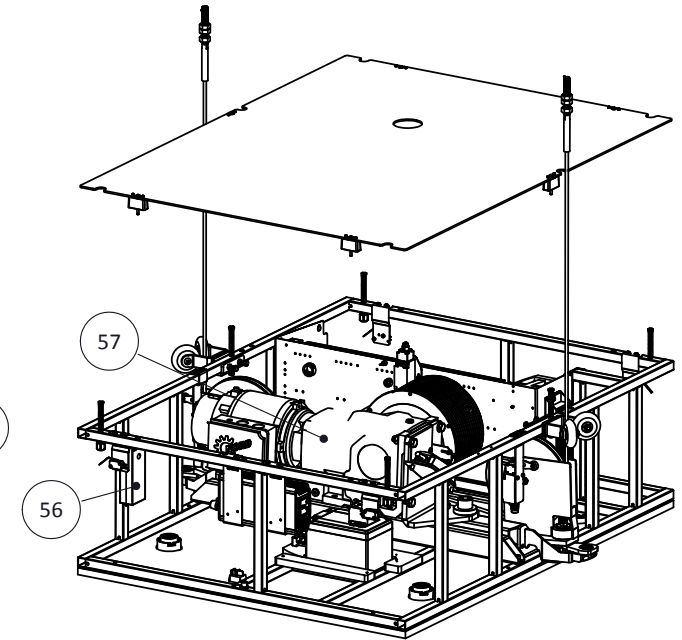
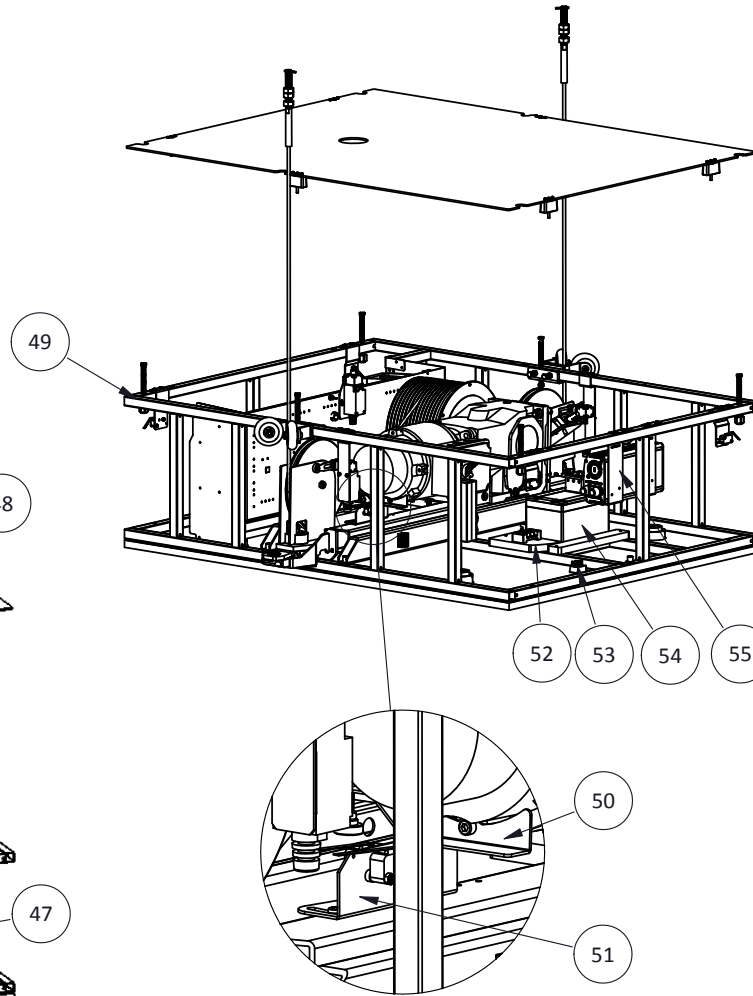
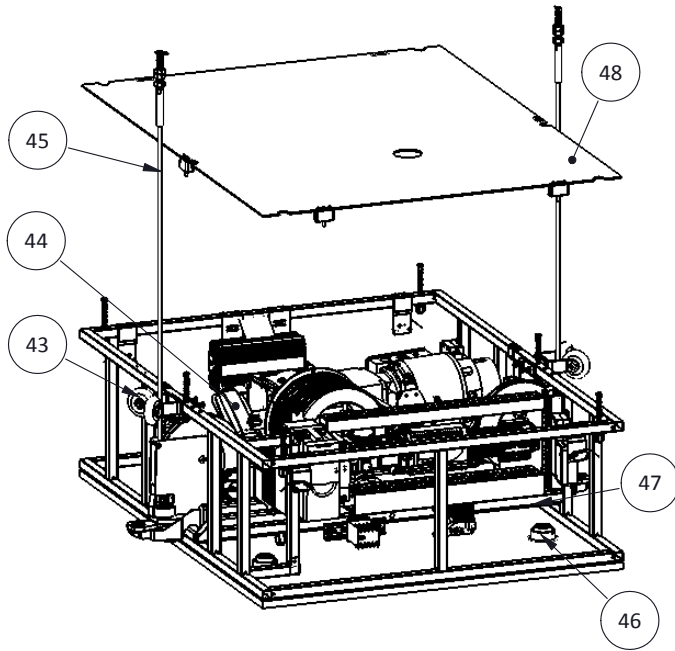

Approved for Manufacture

By: (Sign)
Name:.....

GENERAL TOLERANCES (Unless Noted Otherwise):
 0-30mm ±0.1 30-120mm ±0.2
 120-400mm ±0.3 400-1000mm ±0.5
 1000-2000mm ±1.0 >2000mm ±1.5
 Angular ±0.25 Deg.
Break ALL sharp corners and remove burrs or swarf.



Drawn Wagon Wang		Date 2017/12/14	TITLE Trio Hoist Assembly	
DIMENSIONS IN MM UNLESS OTHERWISE NOTED THIRD ANGLE PROJECTION - AS 1100		A4	Dwg No TRI-1A0BN5N-001	PAGE 6 OF 15
SCALE:				

PRINT MAY BE REDUCED - DO NOT SCALE.

Rev	Description	By	Date
A	New Drawing	Wagon	2017/12/14

Item #	Part Name	Part No.	Qty
43	Duo Guide Roller Assembly	50102-00020	1 Pair
44	CTEK Battery Charger With Bracket Assembly	50104-00022	1
45	Lift Wire Rope 6m Assembly	50102-00007	1 Set
46	LED Light 3X1W	10303-00006	4
47	Trio Electrical Panel Electrical Assembly	50102-00062	1
48	Trio Thru Motor Cover Plate Assembly	50102-00026	1
49	Trio Thru Hoist Mechanical Assembly	50101-00004	1
50	Overload Striker Plate Assembly	50104-00029	1
51	Overload Switch Bracket Assembly	50104-00009	1
52	Trio Battery Retainer Bracket Assembly	50104-00059	1
53	Main Switch	10305-00003	1
54	Lead Acid Battery 12V	50104-00052	1
55	Power Inverter Assembly	50104-00051	1
56	Rear Light Curtain Controller Assembly	50104-00056	1
57	Nord GearBox Motor 550W N2 Assembly	50102-00076	1
58	Interrupt Limit Bolt Assembly 1	50102-00013	4
59	Rocker Beam Swivel Sheave Assembly	50102-00024	1
60	Working Limit Tag Switch Assembly	50104-00007	1 Set
61	Interrupt Limit Bolt Assembly 2	50102-00014	2
62	Balance Limit Striker Assembly	50102-00073	1
63	Interrupt Limit Tag Switch Assembly	50104-00006	1 Set

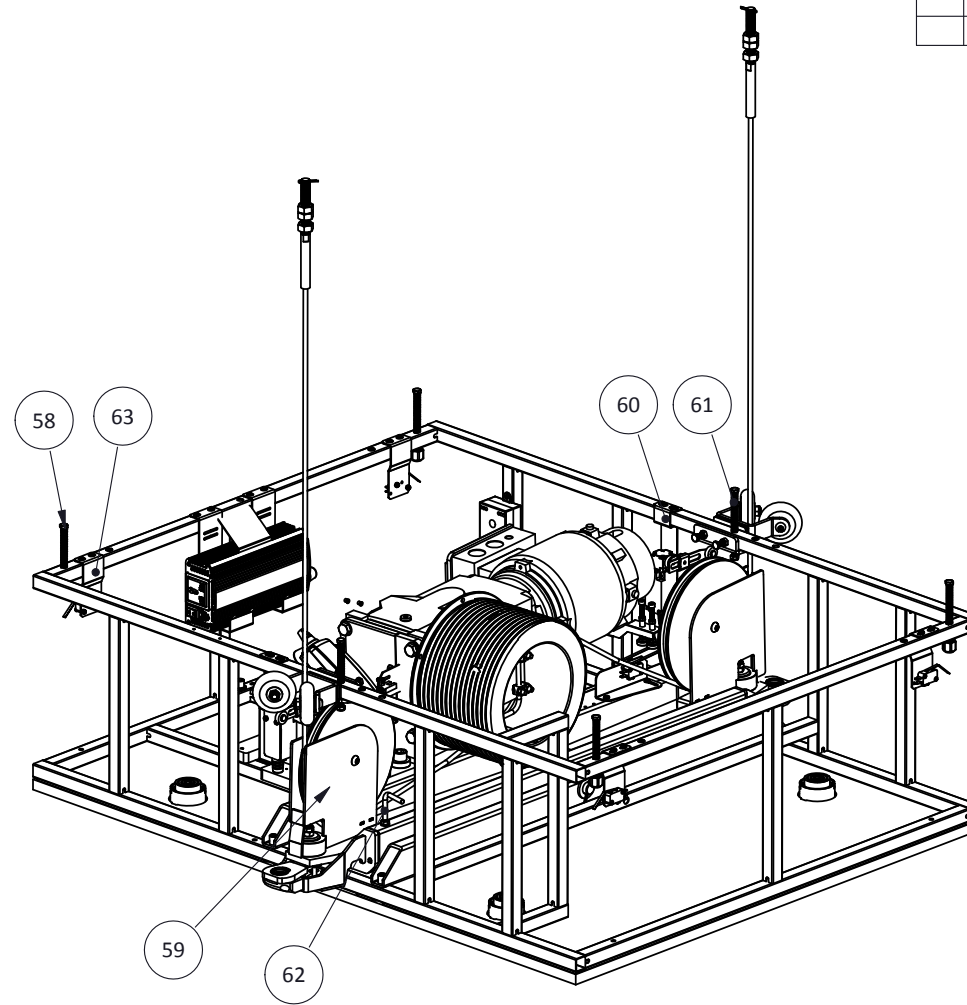

Approved for Manufacture

By: (Sign)
Name:.....

GENERAL TOLERANCES (Unless Noted Otherwise):
 0-30mm ±0.1 30-120mm ±0.2
 120-400mm ±0.3 400-1000mm ±0.5
 1000-2000mm ±1.0 >2000mm ±1.5
 Angular ±0.25 Deg.
Break ALL sharp corners and remove burrs or swarf.

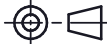

Drawn Wagon Wang		Date 2017/12/14	TITLE Trio Hoist Assembly	
 DIMENSIONS IN MM UNLESS OTHERWISE NOTED THIRD ANGLE PROJECTION - AS 1100		A4	Dwg No TRI-1A0BN5N-001	PAGE 7 OF 15
SCALE:				

PRINT MAY BE REDUCED - DO NOT SCALE.

Item #	Part Name	Part No.	Qty
49.1	Trio Thru Lift Hoist Frame	35105-00025	1
49.2	Hoist Swivel Rocker Beam Assembly	50102-00024	1
49.3	Main Switch	10305-00003	1
49.4	Trio Thru Ceiling plate V.B	28106-00021	1
49.5	LED Light 3X1W	10303-00006	4
49.6	Pivot Pin Assembly	53102-00138	1
49.7	Flat Head Rivet Nut M5	30102-30034	1
49.8	Flat Head Rivet Nut M4	30102-30033	6
49.9	Equaliser Sleeve N1	20102-00007	1
49.10	Equaliser Sleeve N2	20102-00008	1

Rev	Description	By	Date
A	New Drawing	Wagon	2017/07/01

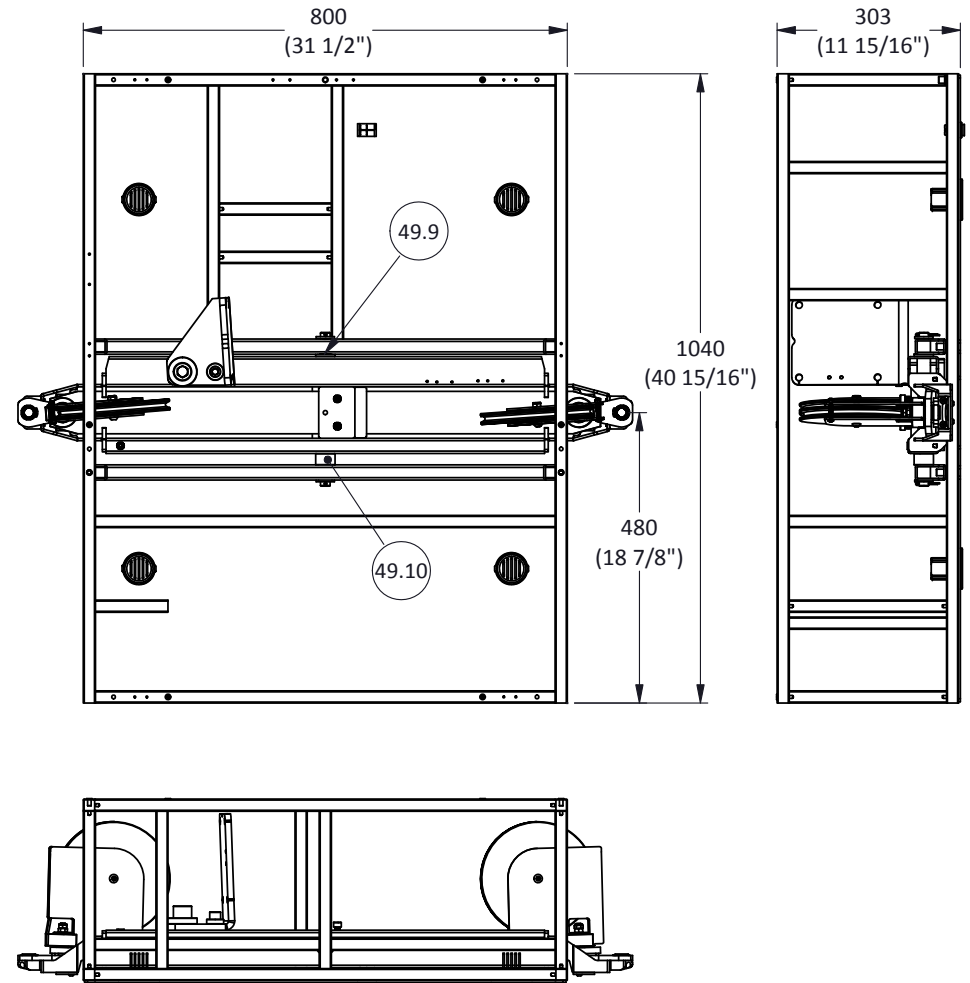
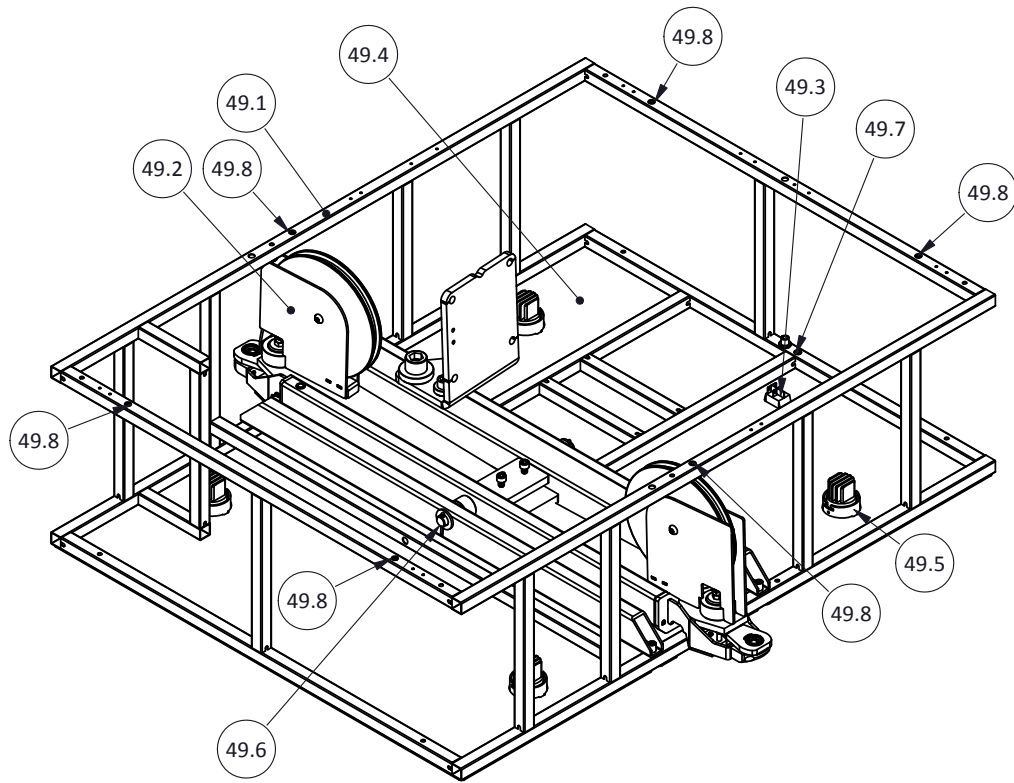

Approved for Manufacture

By: (Sign)
Name:.....

GENERAL TOLERANCES (Unless Noted Otherwise):

0-30mm	±0.1	30-120mm	±0.2
120-400mm	±0.3	400-1000mm	±0.5
1000-2000mm	±1.0	>2000mm	±1.5
Angular	±0.25 Deg.		

Break ALL sharp corners and remove burrs or swarf.

Stiltz

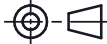
Drawn		Date		TITLE	
Wagon Wang	2017/07/01	Trio Thru Hoist Mechanical Assembly			
 DIMENSIONS IN MM UNLESS OTHERWISE NOTED THIRD ANGLE PROJECTION - AS 1100		A4	Dwg No 50101-00004	PAGE 8 OF 15	
SCALE:					

PRINT MAY BE REDUCED - DO NOT SCALE.

Rev	Description	By	Date
A	New Drawing	Wagon	2017/10/28

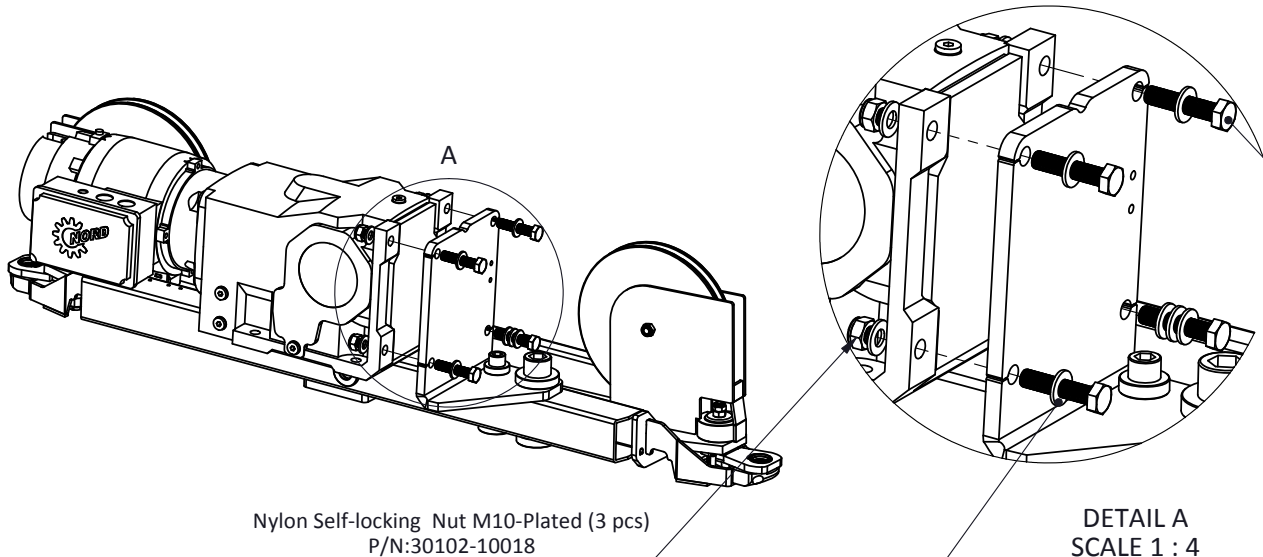

Hex Head Bolt M10*45mm(4 pcs)
P/N:30101-11058

Nylon Self-locking Nut M10-Plated (3 pcs)
P/N:30102-10018

DETAIL A
SCALE 1 : 4

Flat washer $\Phi 20*\Phi 10*2$ mm-Plated (9 pcs)
P/N:30103-10006

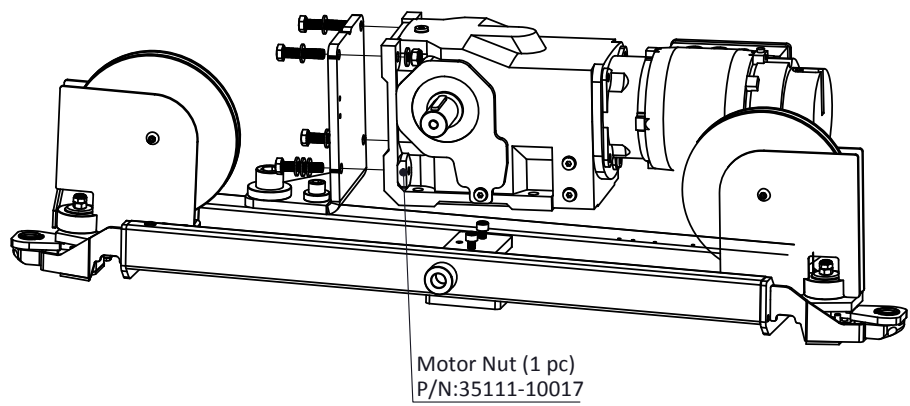

Motor Nut (1 pc)
P/N:35111-10017

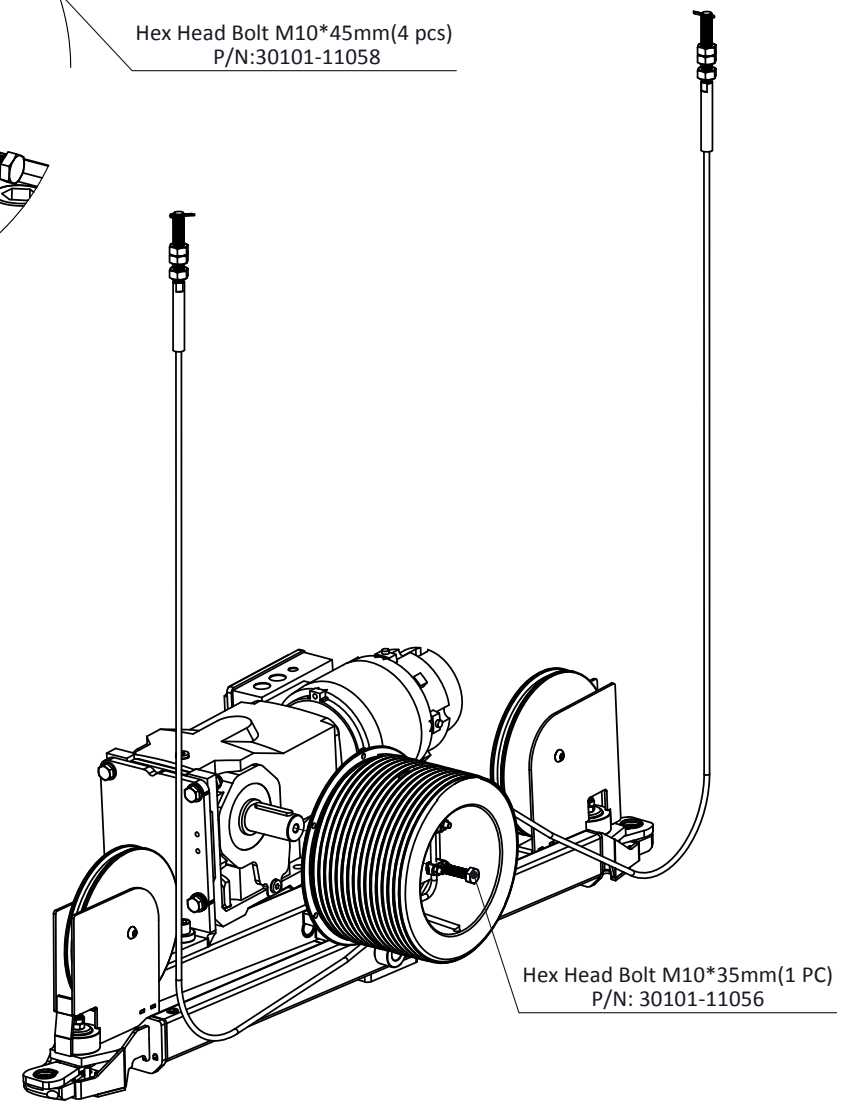

Hex Head Bolt M10*35mm(1 PC)
P/N: 30101-11056

Approved for Manufacture

GENERAL TOLERANCES (Unless Noted Otherwise):

0-30mm	±0.1	30-120mm	±0.2
120-400mm	±0.3	400-1000mm	±0.5
1000-2000mm	±1.0	>2000mm	±1.5
Angular	±0.25 Deg.		

Break ALL sharp corners and remove burrs or swarf.

By: (Sign)
Name:.....



TITLE		Motor Install	
Drawn Wagon Wang	Date 2017/10/28	A4	Dwg No -
THIRD ANGLE PROJECTION - AS 1100			SCALE:

PRINT MAY BE REDUCED - DO NOT SCALE.

Rev	Description	By	Date
A	New Drawing	Wagon	2017/07/07

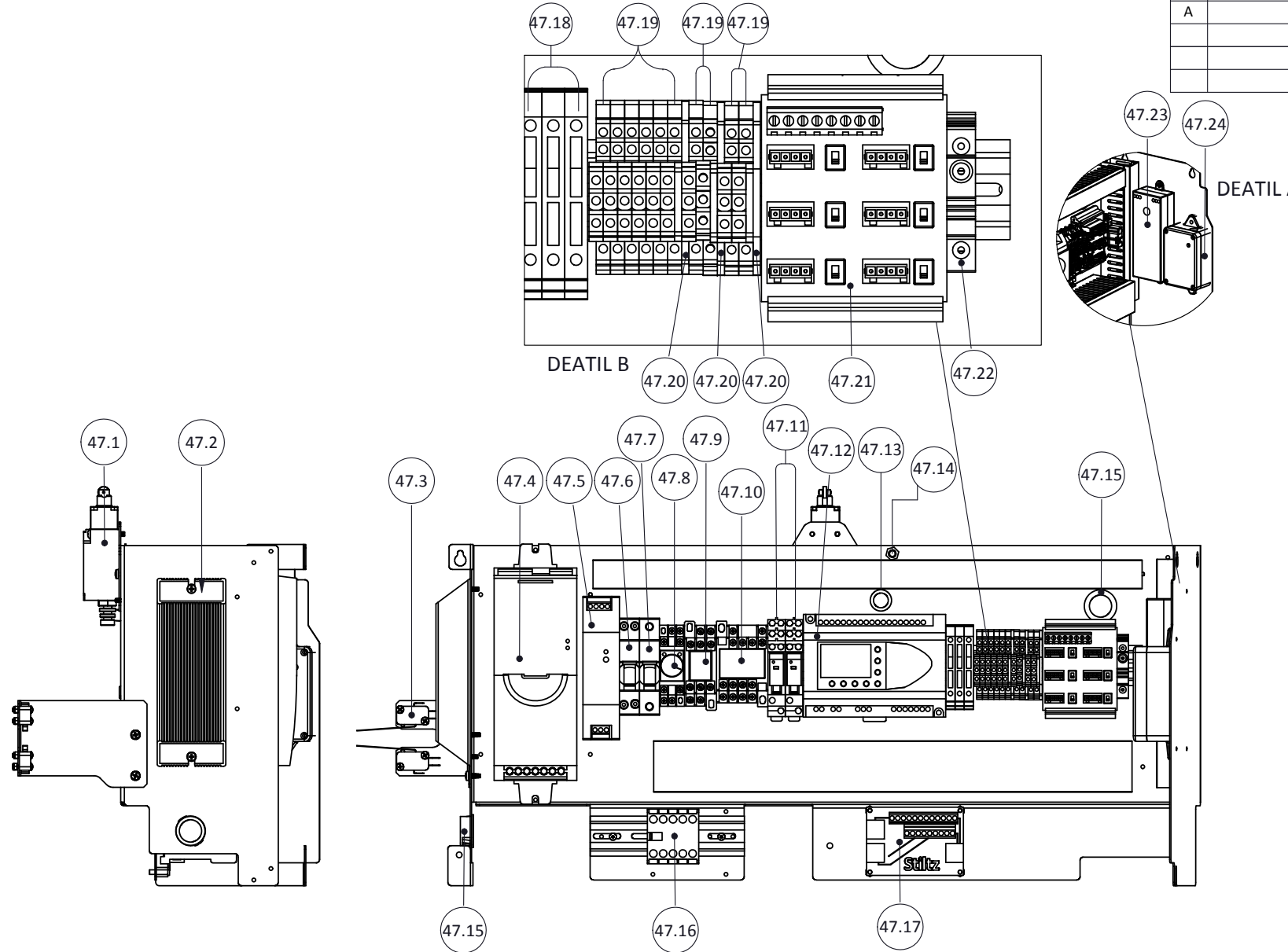

S/N	Product No.	Product Name	Qty
47.1	50104-00004	Extreme Upper Limit Tag Switch Assembly	1
47.2	10203-00003	BBrake Resister N2	1
47.3	50104-00032	Trio Balance Limit Bracket Assembly	1
47.4	10202-00002	Frequency Inverter N1	1
47.5	10701-00003	Power Supply 24V	1
47.6	10101-00001	Circuit Breaker 10A	1
47.7	10101-00002	Circuit Breaker 32A	1
47.8	10103-00007	Timer Relay	1
47.9	10103-00005	Relay AC220/240V	1
47.10	10103-00001	Relay AC200/220V	1
47.11	10103-00003	Relay DC24V	2
47.12	10201-00001	PLC	1
47.13	10908-00003	Cable Bush Φ:16 - Black	1
47.14	10304-00001	Limit Override Push Button	1
47.15	10908-00002	Cable Bush Φ:26 - Black	2
47.16	10102-00011	S1 Contactor LP 1K0901BD DC24	1
47.17	50104-00024	Car Control PCB Assembly	1
47.18	10104-00001	Fuse Terminals	3
47.19	10401-00001	Two Level Terminal	10
47.20	10401-00003	Terminal End Plate	3
47.21	50104-00026	Door Lock Link PCB Assembly	1
47.22	10401-00005	Terminal End Clamp S1	1
47.23	10204-00001	Light Curtain Controller	1
47.24	50104-00005	Remote Control Receiver Assembly	1

Approved for Manufacture

By: (Sign)
Name:.....

GENERAL TOLERANCES (Unless Noted Otherwise):
 0-30mm ±0.1 30-120mm ±0.2
 120-400mm ±0.3 400-1000mm ±0.5
 1000-2000mm ±1.0 >2000mm ±1.5
 Angular ±0.25 Deg.
Break ALL sharp corners and remove burrs or swarf.



Drawn Wagon Wang		Date 2017/07/07		TITLE Trio Electrical Panel Electrical Assembly	
DIMENSIONS IN MM UNLESS OTHERWISE NOTED THIRD ANGLE PROJECTION - AS 1100		A4 Dwg No 50104-00011 SCALE:		PAGE 10 OF 15	

PRINT MAY BE REDUCED - DO NOT SCALE.

Rev	Description	By	Date
A	New Drawing	Guangji	2015/03/20

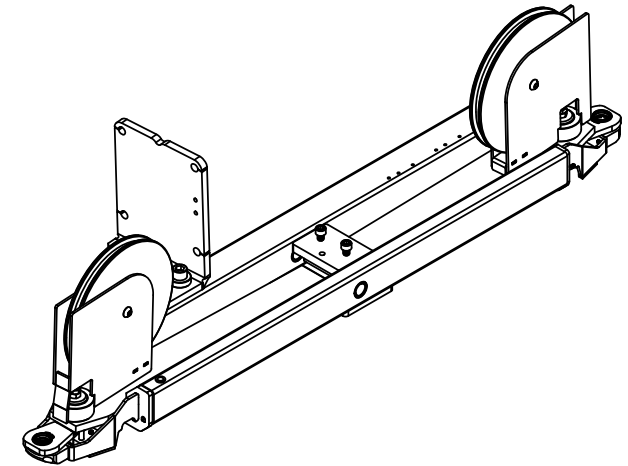
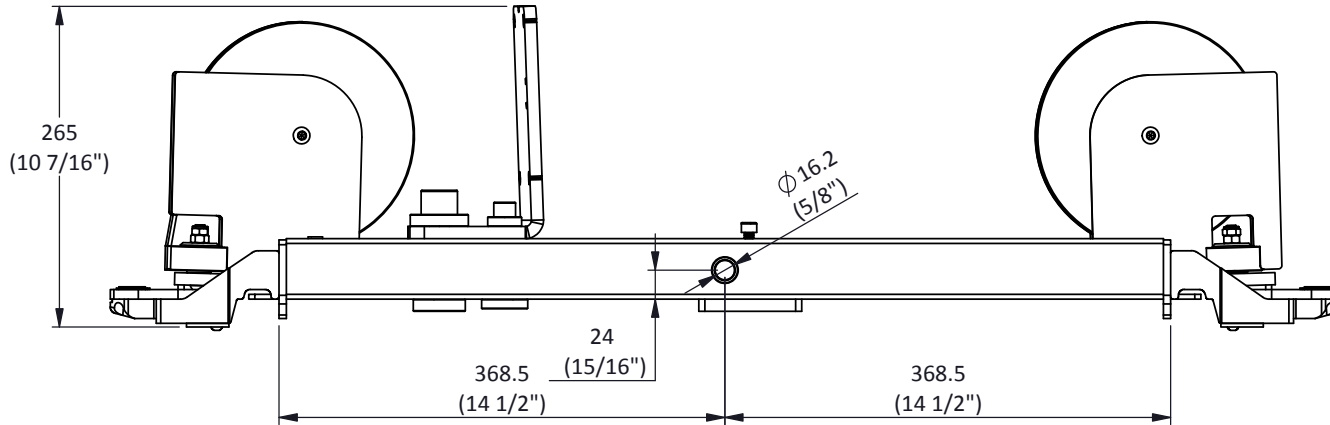
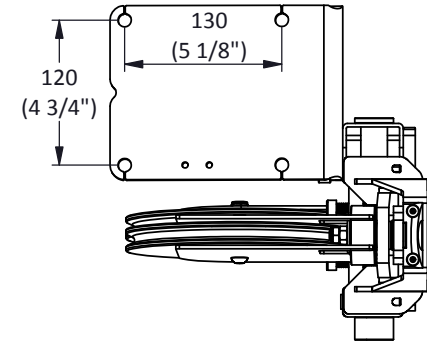
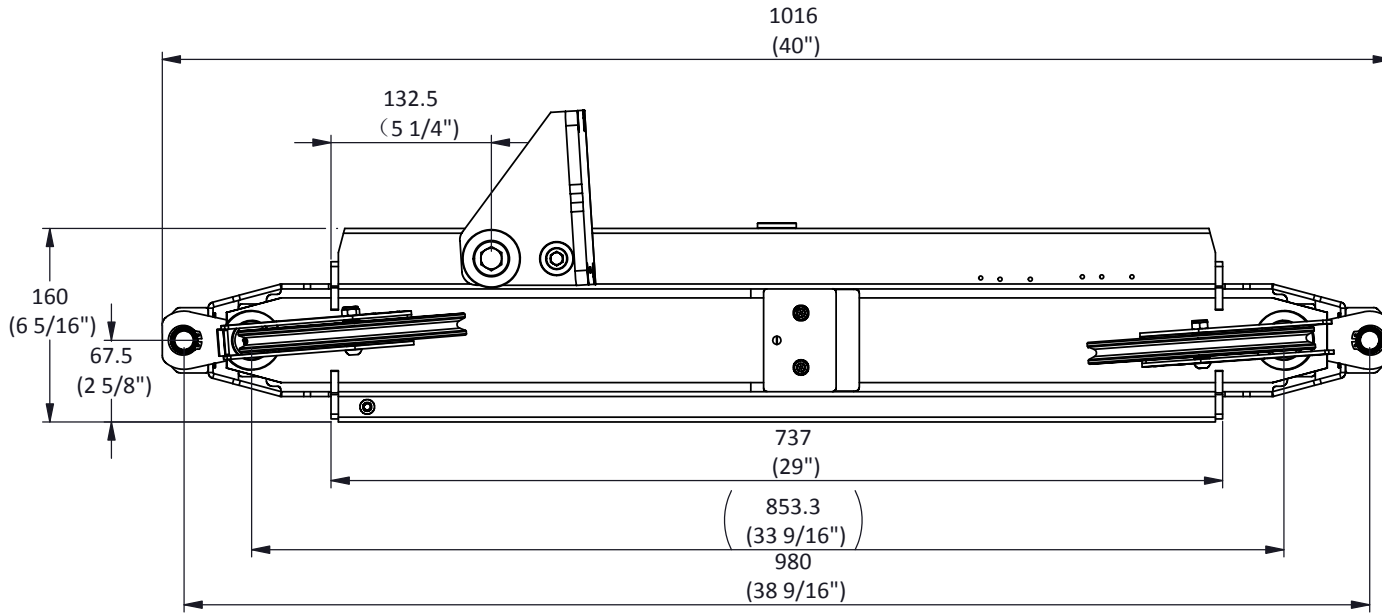

Approved for Manufacture

By: (Sign)
Name:.....

GENERAL TOLERANCES (Unless Noted Otherwise):

0-30mm	±0.1	30-120mm	±0.2
120-400mm	±0.3	400-1000mm	±0.5
1000-2000mm	±1.0	>2000mm	±1.5
Angular	±0.25 Deg.		

Break ALL sharp corners and remove burrs or swarf.

Stiltz

Drawn		Date		TITLE	
Guangji Chen		2015/03/20		Hoist Swivel Rocker Beam Assembly	
 THIRD ANGLE PROJECTION - AS 1100		DIMENSIONS IN MM UNLESS OTHERWISE NOTED		A4 Dwg No 50102-00024	
SCALE:				PAGE 11 OF 15	

PRINT MAY BE REDUCED - DO NOT SCALE.

Rev	Description	By	Date
A	New Drawing	Guangji	2015/03/20

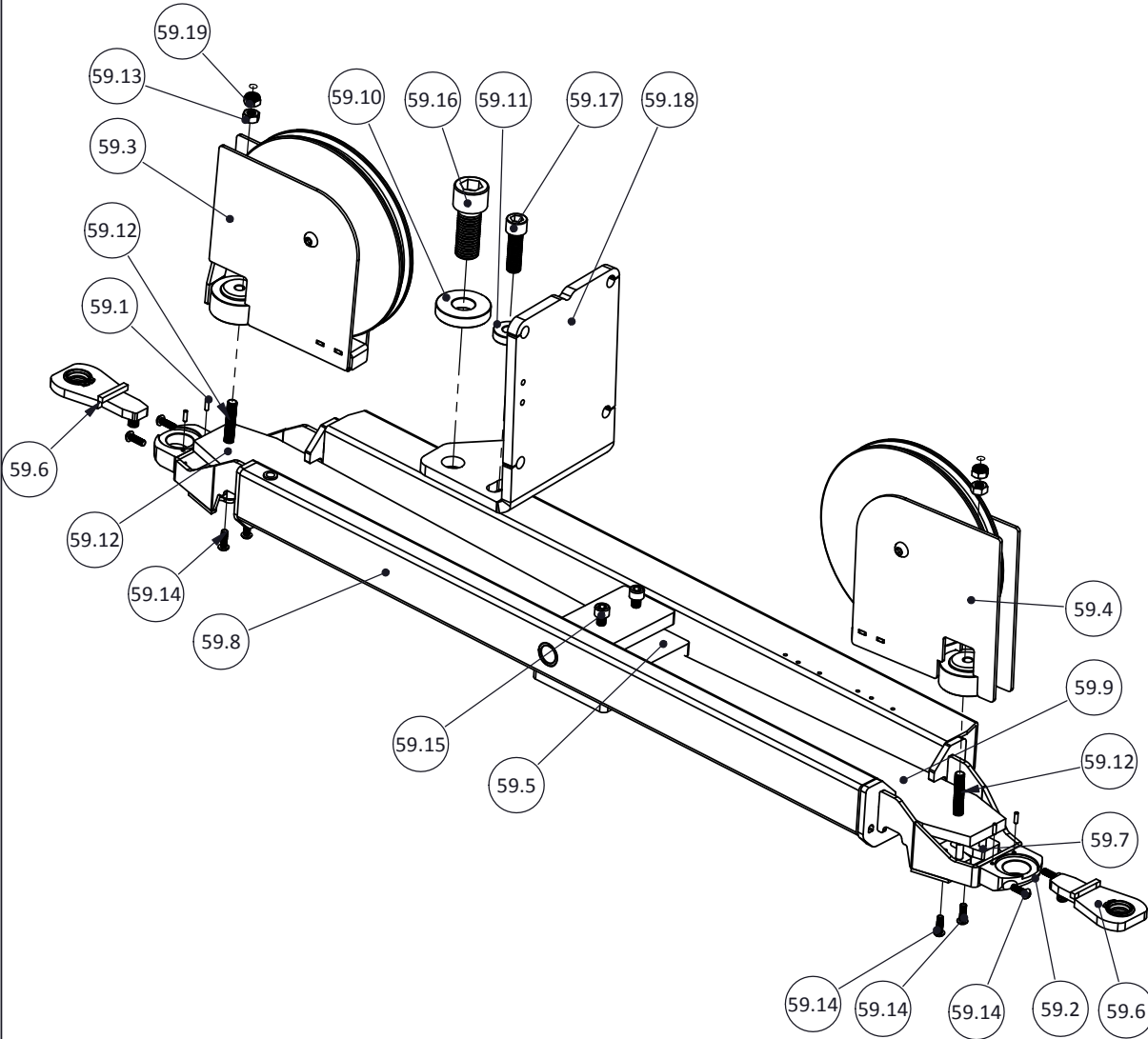

Item #	Part Name	Part No.	Qty
59.1	Magnet Pin OD3x10	30113-00015	4
59.2	Gripper Support V.B	20102-00005	2
59.3	Swivel Sheave Assembly LH V.A	50102-00038	1
59.4	Swivel Sheave Assembly RH V.A	50102-00039	1
59.5	Spring block plate V.A	35111-10035	1
59.6	Gripper Plate II Assembly	50102-00025	2
59.7	Gripper Steady Plate Assembly V.B	35105-10016	2
59.8	Swivel Rocker Beam V.C	35105-10013	1
59.9	Spring II_bend	35111-10030	1
59.10	Pivot Washer V.A	35111-10034	1
59.11	Lock Washer V.A	35111-10033	1
59.12	Socket Button Head Screw M8x50mm	30101-10221	2
59.13	Hexagon Nut M8	30102-10043	2
59.14	SS Socket Button Head Screw M5X16mm	30101-80182	8
59.15	Socket Cap Head Screw M8x35mm	30101-10520	2
59.16	Socket Cap Head Screw M20x50mm	30101-10593	1
59.17	Socket Cap Head Screw M12x40mm	30101-10557	1
59.18	Motor Mount Bracket V.C	35112-10027	1
59.19	Nylon Self-locking Nut M8	30102-10017	2

Approved for Manufacture

By: (Sign)
Name:.....

GENERAL TOLERANCES (Unless Noted Otherwise):

0-30mm	±0.1	30-120mm	±0.2
120-400mm	±0.3	400-1000mm	±0.5
1000-2000mm	±1.0	>2000mm	±1.5
Angular	±0.25 Deg.		

Break ALL sharp corners and remove burrs or swarf.

Stiltz

Drawn		Date		TITLE	
Guangji Chen		2015/03/20		Hoist Swivel Rocker Beam Assembly	
 DIMENSIONS IN MM UNLESS OTHERWISE NOTED THIRD ANGLE PROJECTION - AS 1100		A4 Dwg No 50102-00024 SCALE:		PAGE 12 OF 15	

PRINT MAY BE REDUCED - DO NOT SCALE.

28

Rev	Description	By	Date
A	New Drawing	Guangji	2015/03/21

Item #	Part Name	Part No.	Qty
59.3.1	Swivel Sheave Bracket LH V.A	35105-10014	1
59.3.2	Sheave Pivot V.A	35111-10032	1
59.3.3	Sheave Guide Bush	30113-00018	1
59.3.4	Swivel Block V.B	20102-00006	1
59.3.5	Nylon Sheave Assembly	50102-00001	1
59.3.6	Socket Button Head Screw M8X35mm	30101-10218	1
59.3.7	Nylon Self-locking Nut M8	30102-10017	1

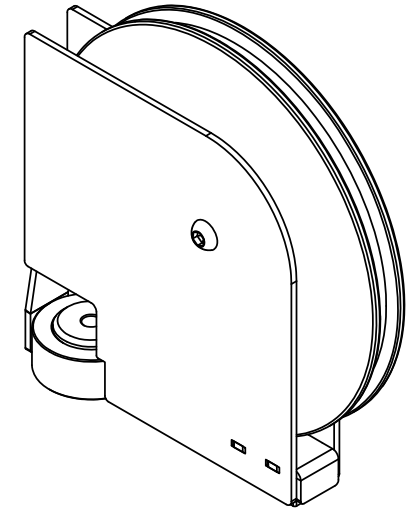
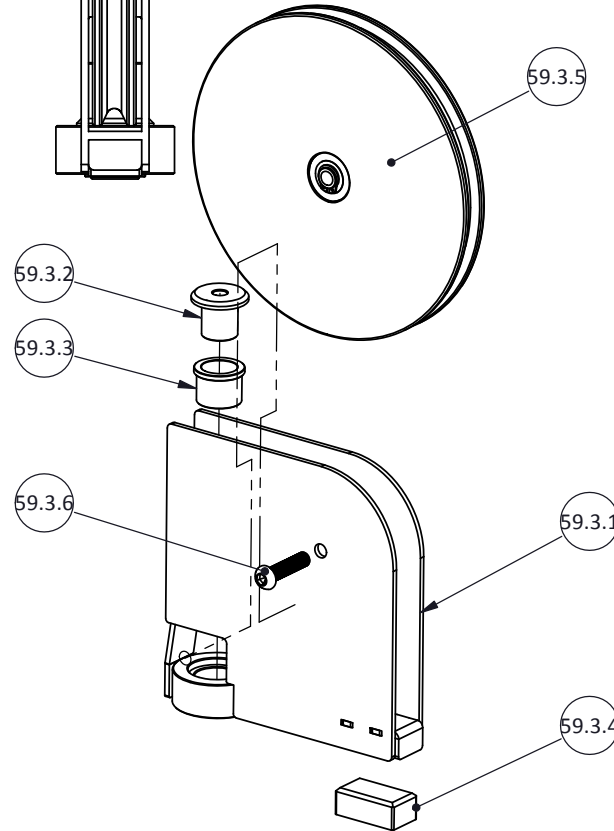
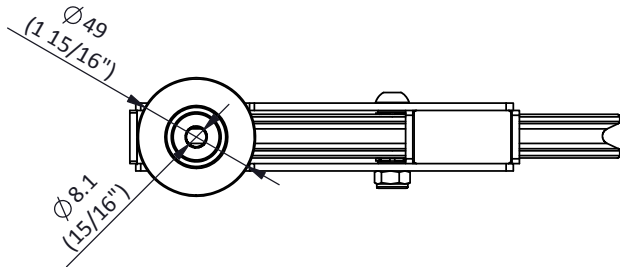
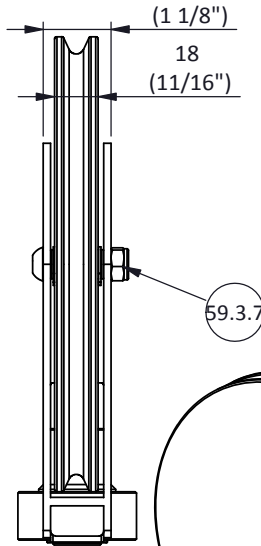
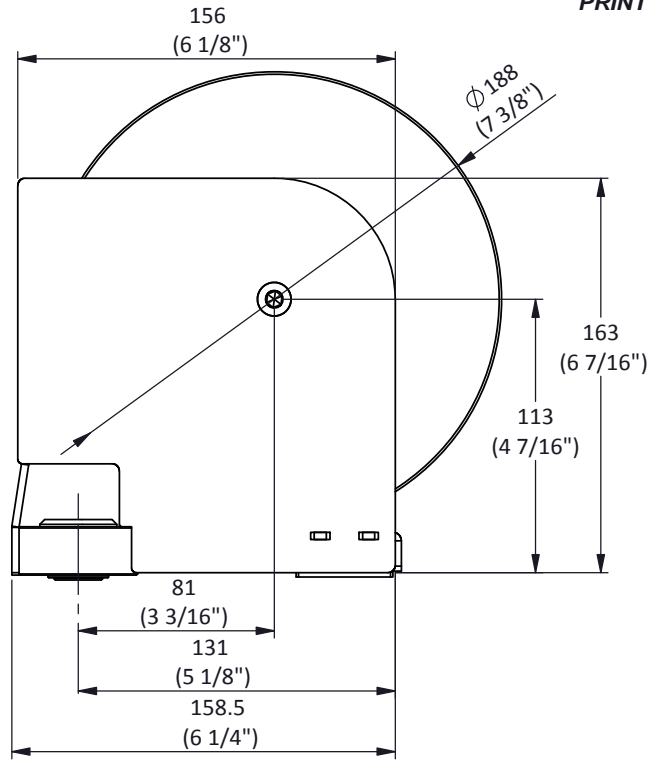

Approved for Manufacture

By: (Sign)
Name:.....

GENERAL TOLERANCES (Unless Noted Otherwise):
 0-30mm ±0.1 30-120mm ±0.2
 120-400mm ±0.3 400-1000mm ±0.5
 1000-2000mm ±1.0 >2000mm ±1.5
 Angular ±0.25 Deg.
Break ALL sharp corners and remove burrs or swarf.



Drawn		Date		TITLE	
Guangji	Chen	2015/03/21		Swivel Sheave Assembly LH V.A	
THIRD ANGLE PROJECTION - AS 1100		DIMENSIONS IN MM UNLESS OTHERWISE NOTED		A4	Dwg No 50102-00038
				SCALE:	PAGE 13 OF 15

PRINT MAY BE REDUCED - DO NOT SCALE.

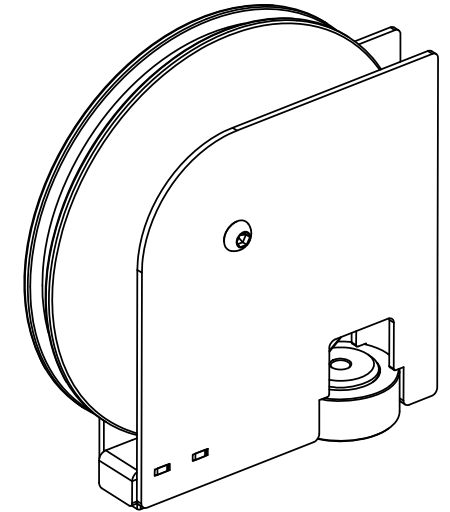
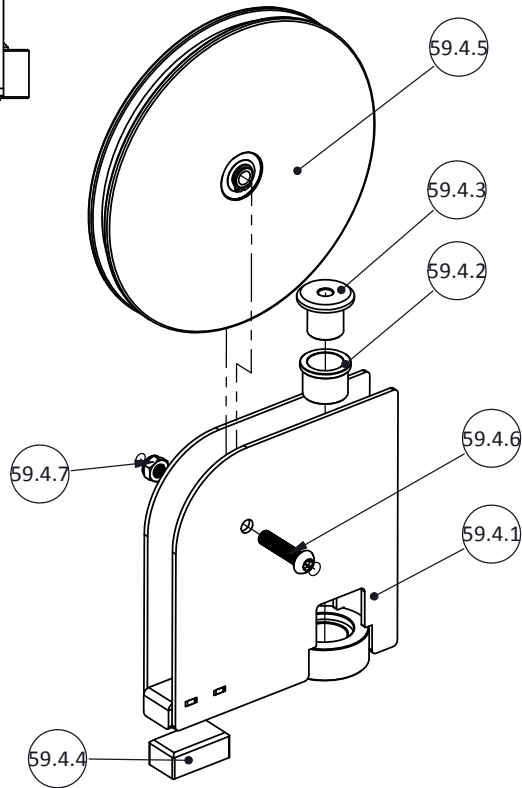
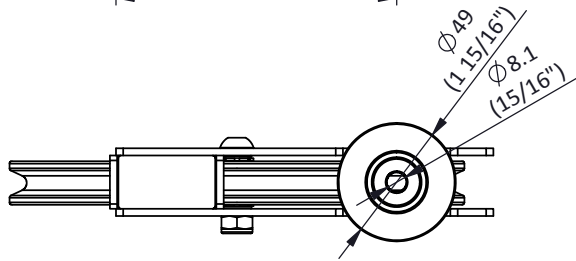
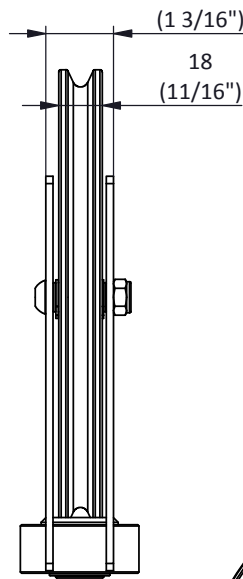
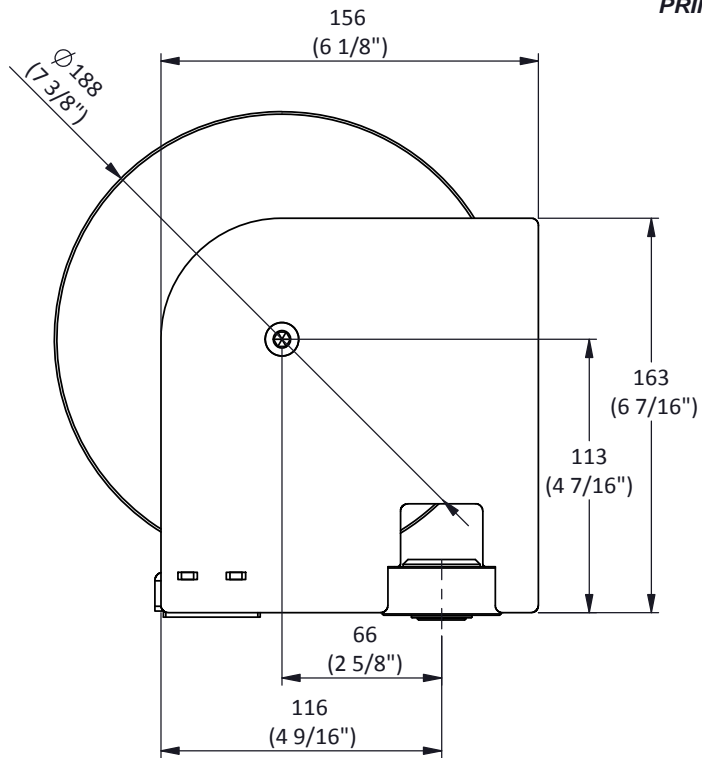

Rev	Description	By	Date
A	New Drawing	Guangji	2015/03/21

Item #	Part Name	Part No.	Qty
59.4.1	Swivel Sheave Bracket RH V.A	35105-10015	1
59.4.2	Sheave Guide Bush	30113-00018	1
59.4.3	Sheave Pivot V.A	35111-10032	1
59.4.4	Swivel Block V.B	20102-00006	1
59.4.5	Nylon Sheave Assembly	50102-00001	1
59.4.6	Socket Button Head Screw M8X35mm	30101-10218	1
59.4.7	Nylon Self-locking Nut M8	30102-10017	1

Approved for Manufacture

By: (Sign)
Name:.....

GENERAL TOLERANCES (Unless Noted Otherwise):

0-30mm	±0.1	30-120mm	±0.2
120-400mm	±0.3	400-1000mm	±0.5
1000-2000mm	±1.0	>2000mm	±1.5
Angular	±0.25 Deg.		

Break ALL sharp corners and remove burrs or swarf.

Stiltz

Drawn		Date		TITLE	
Guangji Chen		2015/03/21		Swivel Sheave Assembly RH V.A	
 THIRD ANGLE PROJECTION - AS 1100		DIMENSIONS IN MM UNLESS OTHERWISE NOTED		A4	Dwg No 50102-00039
SCALE:				PAGE	14 OF 15

PRINT MAY BE REDUCED - DO NOT SCALE.

Rev	Description	By	Date
A	New drawing	Guangji	2015/03/21

Item #	Part Name	Part No.	Qty
59.6.1	Gripper Plate II	35105-10020	1
59.6.2	Gripper spring	30105-00001	1
59.6.3	Circlips For Shaft Ø22mm	30111-00010	1
59.6.4	Gripper Insert Assembly	50102-00025A	1

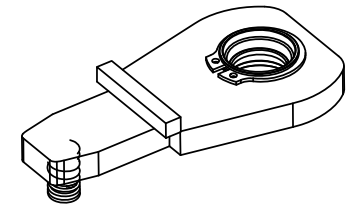
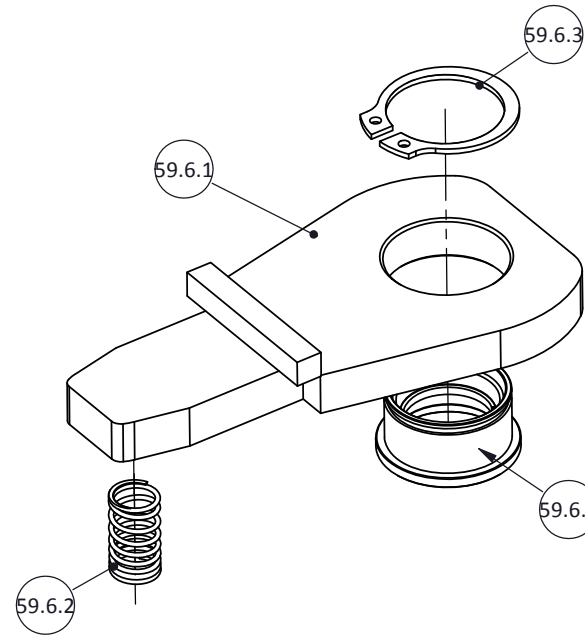
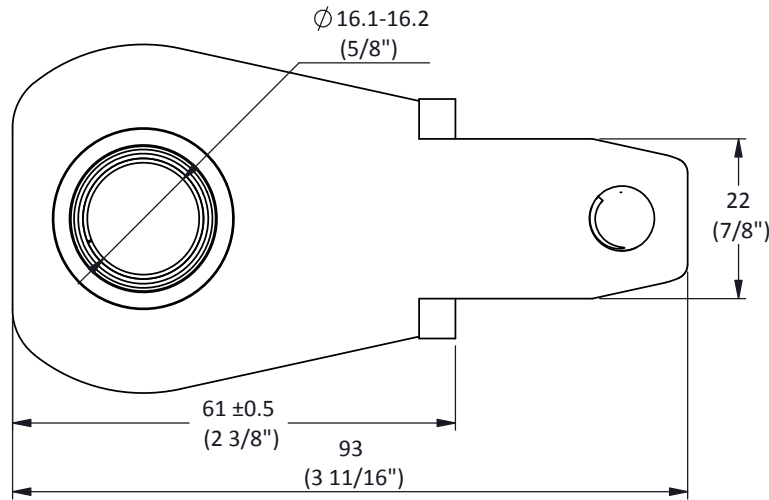
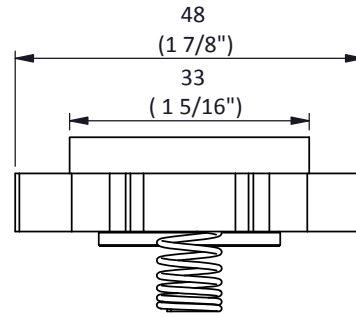
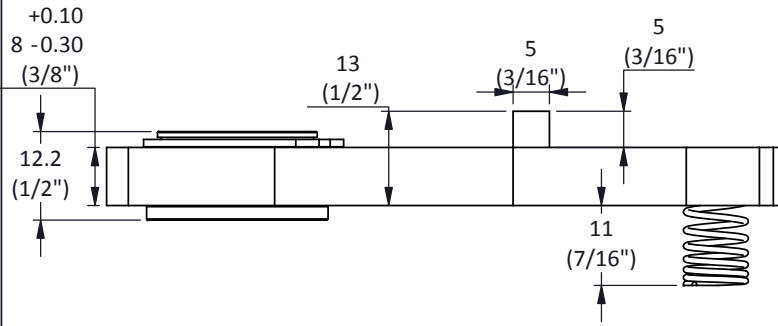

Approved for Manufacture

By: (Sign)
Name:.....

GENERAL TOLERANCES (Unless Noted Otherwise):
 0-30mm ±0.1 30-120mm ±0.2
 120-400mm ±0.3 400-1000mm ±0.5
 1000-2000mm ±1.0 >2000mm ±1.5
 Angular ±0.25 Deg.
Break ALL sharp corners and remove burrs or swarf.



Drawn Guangji Chen		Date 2015/03/21	TITLE Gripper Plate II Assembly	
DIMENSIONS IN MM UNLESS OTHERWISE NOTED THIRD ANGLE PROJECTION - AS 1100		A4	Dwg No 50102-00025	PAGE 15 OF 15
SCALE:				