

Installation instructions

**fohen**

# Fohen Futura Fizz

**Model :**

KM105U 5-in-1 Boiling, Chilled & Sparkling system (all models)



## Table of contents

Table of contents.....	2
Using these instructions.....	3
Explanation of symbols.....	3
<b>IMPORTANT SAFETY INSTRUCTIONS</b> .....	<b>3</b>
Warnings and regulatory information.....	5
Installation checklist.....	7
How to install the Tap.....	8
Position the tap & cut the tap hole.....	9
Tap features and connections.....	10
Mount & secure the tap.....	11
The under counter appliance.....	12
How to install the under counter appliance.....	13
Positioning and ventilation.....	13
Plumbing connections.....	14
CO2 connections.....	15
Connect the system together.....	16
Commissioning, setting and operation.....	17
Set up the chilled water system and flush the filter.....	17
Set up the sparkling water system.....	18
Set up the boiling water system.....	19
Adjust the boiling water set point.....	20
Mixed water dispense.....	21
Boiling, chilled and sparkling functionality.....	22
Chilled & sparkling water dispense.....	24
Boiling water dispense.....	25
Filter replacement.....	26
UV lamp replacement.....	27
Cleaning.....	28
Trouble shooting.....	29
Contact details.....	32

## Explanation of symbols



Read the instructions



WARNING



DANGER  
Electric shock



DANGER  
Hot surface



DANGER  
Flammable



CO<sub>2</sub> Gas  
WARNING



Button/  
coin battery

## Safety instructions



Read and use the instructions and safety information supplied with individual kit components for a safe installation.

### IMPORTANT SAFETY INSTRUCTIONS



## Compliance

In the UK the system must be installed in accordance with water supply byelaws, current IEE regulations and local authority byelaws.

## Safety

This appliance is not intended for use by children under 8 years or persons (including children under 8 years) with reduced physical, sensory or mental capabilities, or lack of experience and knowledge, unless they have been given supervision or instruction concerning the use of the appliance by a person responsible for their safety. Children should be supervised to ensure that they do not play with the appliance.



## Refrigerant

**WARNING! KEEP VENTILATION OPENINGS IN THE APPLIANCE ENCLOSURE OR IN THE BUILT-IN STRUCTURE CLEAR OF OBSTRUCTION.**

The appliance uses **HIGHLY FLAMMABLE R290** refrigerant under pressure. Check the rating plate or contact us before commencing work. Maintenance of the refrigeration unit must be carried out by an accredited service provider or qualified refrigeration technician.

- Do not use mechanical devices or other means to accelerate the defrosting process, other than those recommended by the manufacturer.

## CO<sub>2</sub>

- Keep out of reach of children.
- Use according to MSDS (material safety data sheet).
- Pressurised container. Contains gas under pressure, may explode if heated.
- Protect from sunlight.
- Do not expose to temperatures exceeding 50°C.
- Do not expose to naked flame or any incandescent material.
- Do not pierce or burn, even after use. Avoid shock.
- High concentration of gas may cause asphyxiation.
- Use only in an upright position.
- The cylinder must be used with the supplied pressure regulator.
- The gas cylinder must be installed in an open plan area, or in an enclosed room with a volume no less than 22m<sup>3</sup> per 1200g cylinder, If more than 1 gas cylinder containing CO<sub>2</sub> is present within the same location, the recommended ventilated area should be in proportion to the number of gas cylinders stored in that location. A ventilated area is a non-enclosed area which could include the kitchen, living room etc.
- Refer to the gas cylinder and MSDS for a complete list of warnings ([www.fohen.co.uk](http://www.fohen.co.uk)).



## Qualifications

To avoid hazards, all installation procedures must be carried out by a suitably qualified tradesperson.

The power cable and power outlet must be in a safe visible position for connection.

## Venting

Sometimes steam and / or boiling water droplets may discharge through a vent outlet on the tap. If not using the font, ensure the tap body is located so the tap outlet safely dispenses into the sink bowl.

## Lifting

Take care when lifting. The appliance may exceed safe lifting limits. If you feel this is beyond your personal capabilities, please seek assistance with the lift. The weight of the Command Centre is marked on the packaging. Do not lift the Command Centre by the front cover or any of its connections.

## Airflow

The appliance operates within the ambient temperature range 5°C - 35°C. Proper air circulation must be provided. The system will operate satisfactorily only if the recommended air gaps are provided. The vent kit supplied must be fitted.



- For continued safety of this appliance it must be installed, operated and maintained in accordance with the manufacturer's instructions.
- This appliance may deliver water at high temperature, refer to local requirements and installation instructions to determine if additional delivery temperature control is required.
- The appliance must be earthed, earthing is provided via the supplied power cord. The resistance of the earth connection to each exposed metal part must be less than 1Ω. Use the power cable supplied. It is the responsibility of the installer to ensure the power point is earthed.
- All installation and service work must be completed by trained and suitably qualified tradespeople. Faulty operation due to unqualified persons working on this product, may void warranty coverage.
- As the installer, it is your responsibility to supply and install all valves as required by local regulations and relevant standards.
- The appliance is rated for 220-240V 50Hz AC operation.
- Do not remove the cover of the appliance under any circumstances without first isolating the appliance from the power supply.
- Connect only to a potable (wholesome, cat1) mains water supply.
- Never locate the system near, or clean with water jets.
- Do not expose the appliance to the elements of nature.
- Use of tools can be hazardous, assess the risks before you start.
- A clearance behind the appliance must be provided to allow adequate ventilation for the safe and effective use of the system.
- Valve and fitting threads must be sealed appropriately with PTFE tape where compression seals are not provided.
- Always flush new filter before use.
- Do not over tighten plumbing and hose connections.
- Braided hoses supplied cannot be lengthened.
- Be aware of the risks of hazards which could cause harm when handling compressed CO<sub>2</sub>. Assess the risks before starting the installation.
- Do not proceed with a CO<sub>2</sub> cylinder change if the seals are damaged. Take care not to cross thread the regulator, a cross threaded regulator poses a potential hazard.
- Care must be taken when working with high pressure carbon dioxide, and in no case should the normal operating pressure of 3.0 bar be exceeded.
- The power cord and general power outlet must be in a safe and accessible position after installation. When positioning



the appliance, ensure the power supply cord is not trapped or damaged. If the power supply cord is damaged it must be replaced by a Fohen service provider or a qualified electrician.



- Do not locate multiple portable socket-outlets or portable power supplies at the rear of the appliance.



- For safe operation, the appliance is designed to be installed, commissioned and used within 48 hours. Should the appliance not be required for an extended period of time, do not fill and commission the appliance until ready for first use.



- For water taste and quality reasons, following any non-use period of more than 48 hours, Zip recommends to perform a system flush. Failure to flush the system may affect water quality.



- For UK, this appliance incorporates adequate backflow prevention in accordance to S.I.1999 No.1148 The Water Supply (Water fittings) Regulations 1999 Schedule 2 requirement. No further backflow prevention is required for connection to the water supply.



- For UK, this appliance only contains materials that conform to the requirements of BS6920:2014 'Suitability of non metallic materials and products for use in contact with water intended for human consumption with regard to their effect on the quality of water'.
- Use the new hose set supplied with the unit. Do not re-use old hose set.
- The button/coin battery is hazardous and is to be kept away from children. It can cause severe or fatal injuries in 2 hours or less if it is swallowed or placed inside any part of the body. Medical attention should be sought immediately if it is suspected the battery has been swallowed or placed inside any part of the body.

## Installation checklist



- Check if there is adequate space to install all of the components.
- Note Not all fittings are supplied with the appliance kit. Isolation valves are not supplied.



- Check the mains water pressure is within min / max requirements.
- Check the water quality to determine if extra filtration will be required.
- Note This product must be fitted to a wholesome water supply.



- Check the appliance rating plate and ensure correct power is available.
- Check the under counter cupboard floor supporting the appliance is adequate for its total weight, when full of water.



### **Before commissioning**

- Check the system has been installed correctly.
- Check all plumbing fittings for water tightness.
- Ensure the outlet and vent pipes are positioned to drain correctly.
- Ensure there is adequate ventilation.
- Check all tubes and pipes from the appliance to the tap have a constant rise and there are no sags or kinks in the hoses.



### **Commissioning**

- Flush the supply line before connecting.
- Turn on the water and check for leaks.
- Flush the filter.

## Tap components

Please check the parts are all correct in the box, and read the manual thoroughly, to install and use the tap by following instruction to avoid damage.

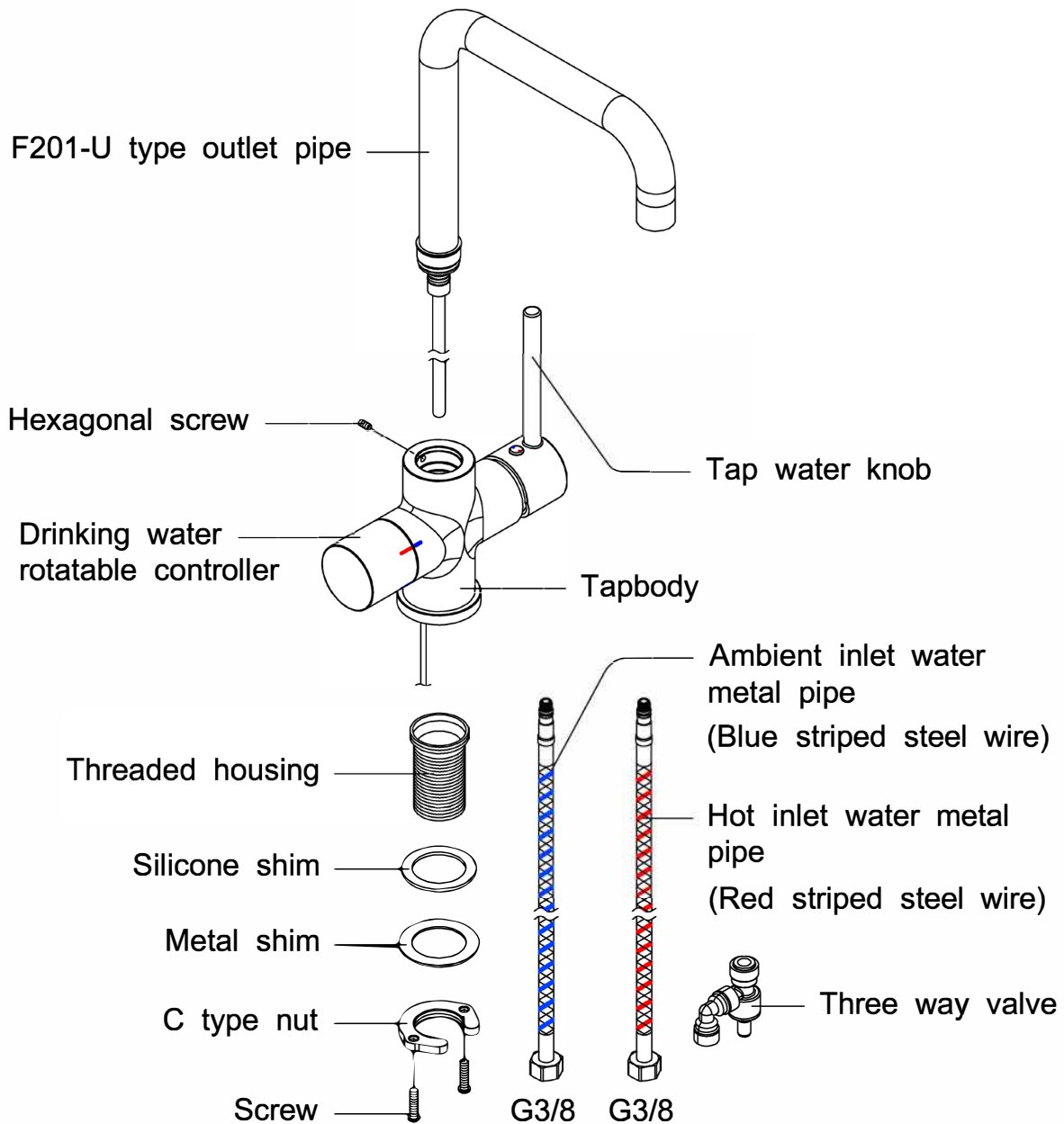



## Position the tap & cut the tap hole

1. Please find the area on the table that is more than 50mm away from the wall, then drill a hole between the  $\phi 32\text{mm}$  to  $\phi 35\text{mm}$  for tap installation.

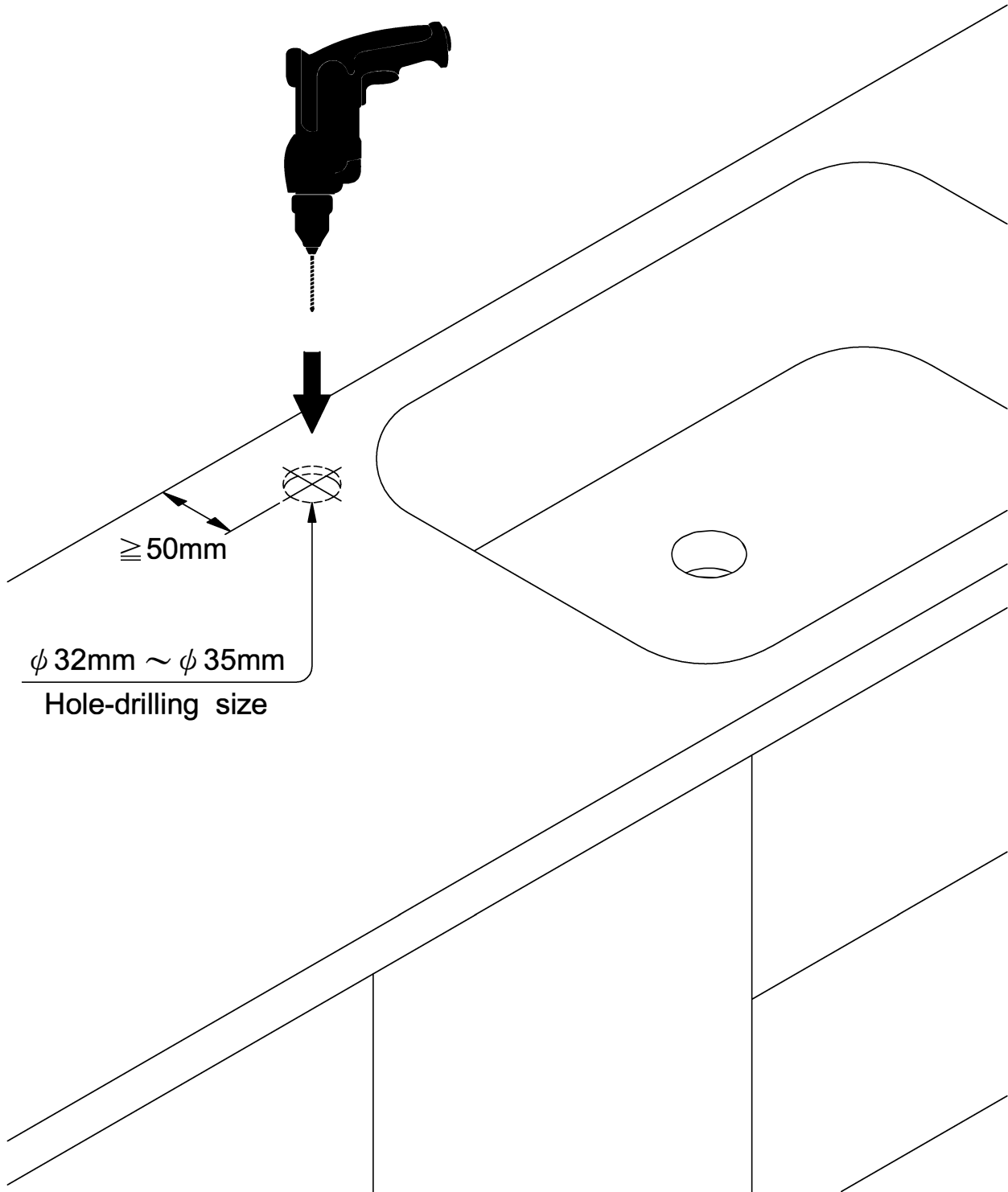

## Tap features and connections

2. Follow the marked position in the image below, insert hot and ambient inlet water pipes to the correspond hole then spin the pipe to fix them into the tap body.

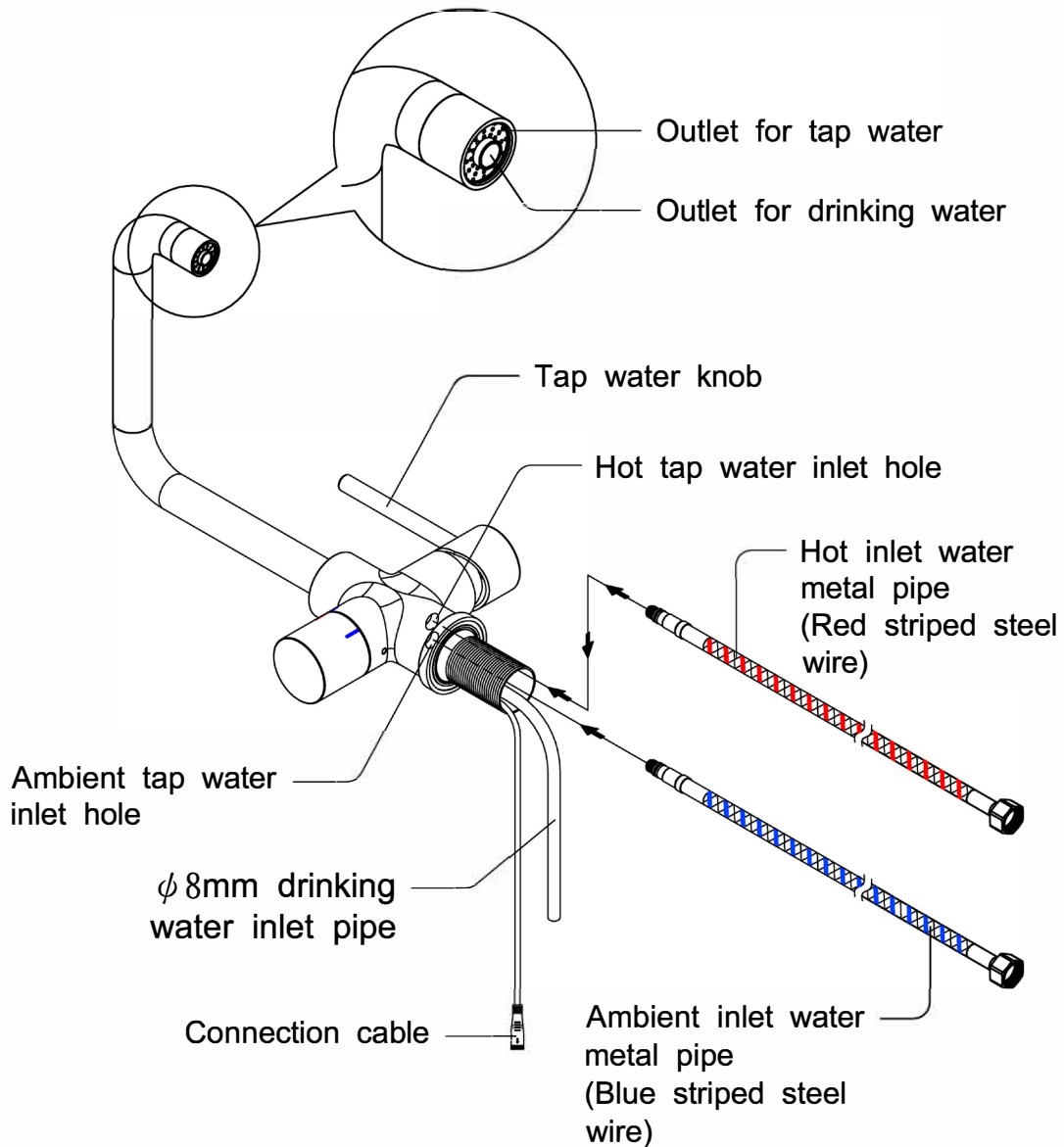

## Mount & secure the tap

3. After tap is assembled, insert threaded housing into drilled hole including all pipes and the cable.

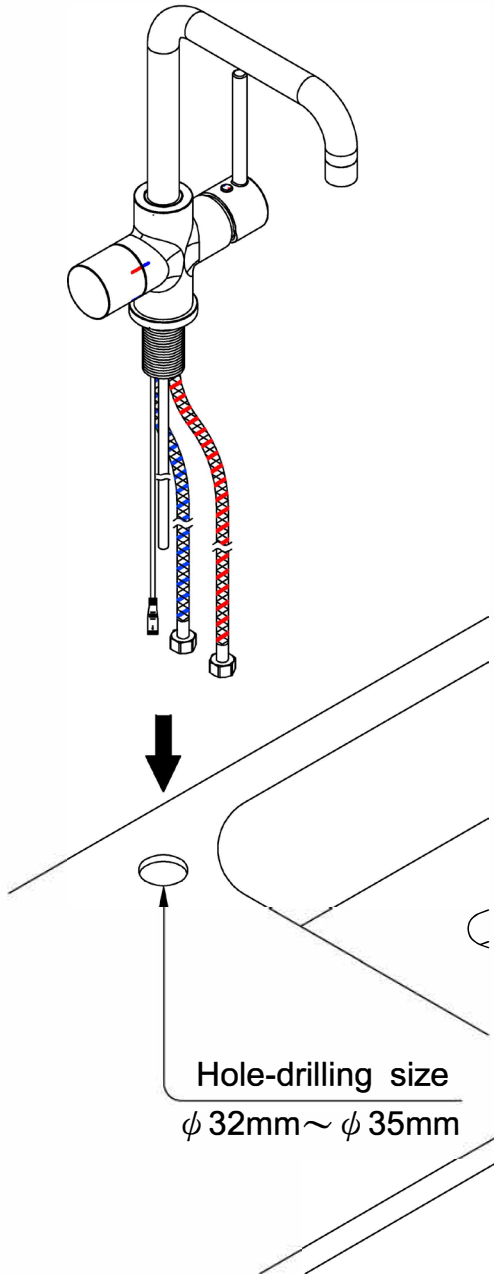

4. Follow the sequence as marked in below image, install silicone shim, metal shim, and C type nut, then tighten the screws.

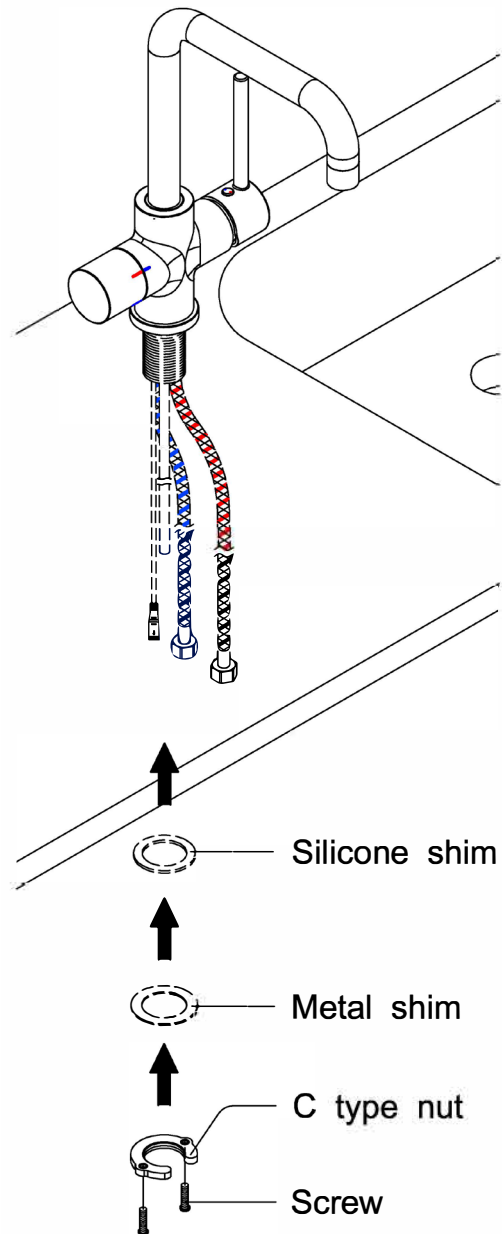

# The under counter appliance

## Features



For continued safety of this appliance it must be installed, operated and maintained in accordance with the manufacturer's instructions.

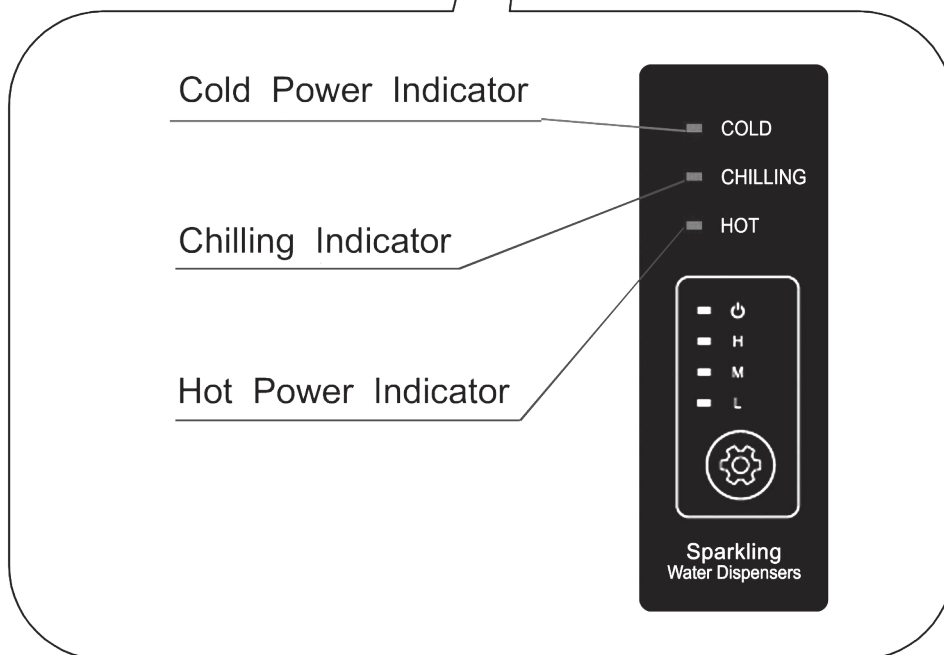
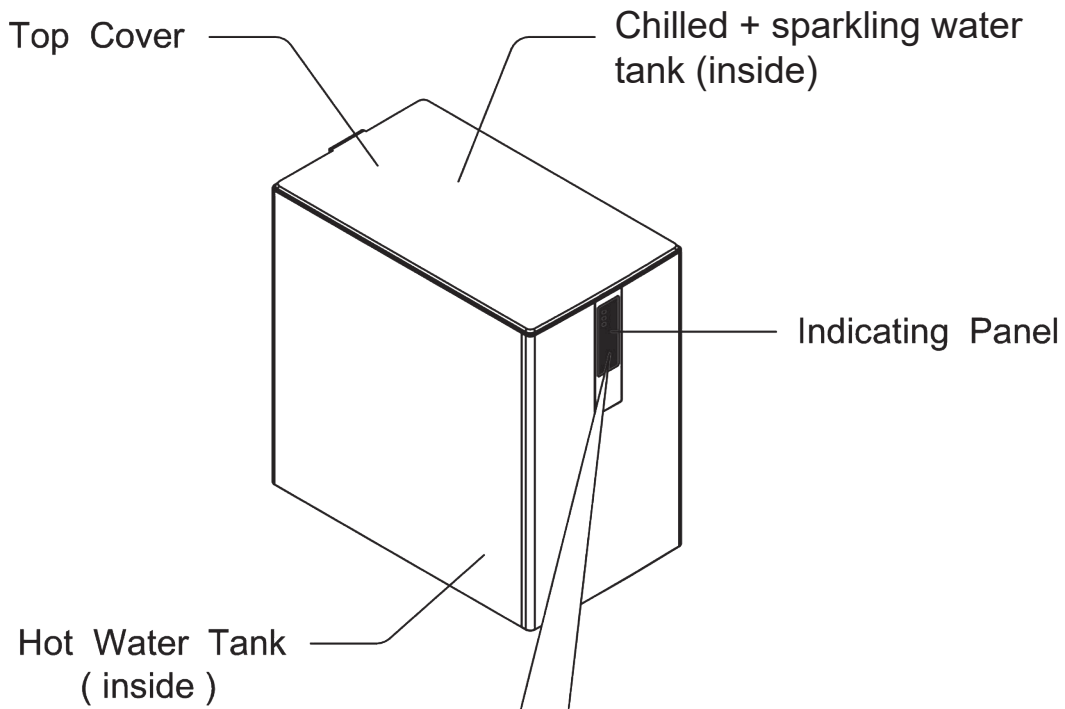

## Positioning and ventilation

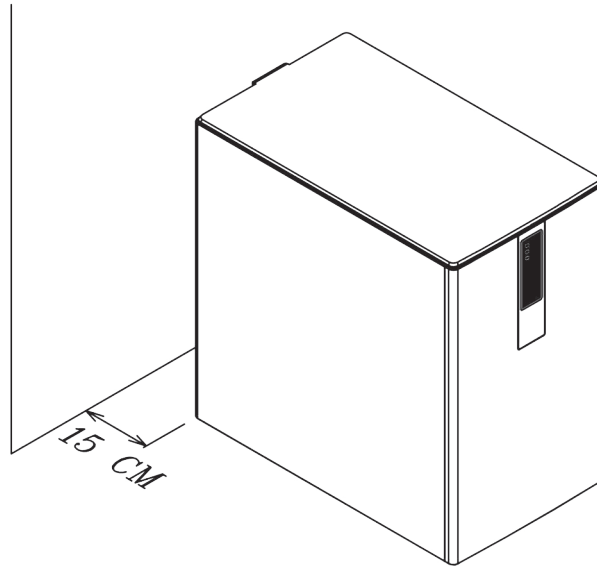

Please consider ventilation, leave some space no less than 15 cm between the wall and water dispenser.

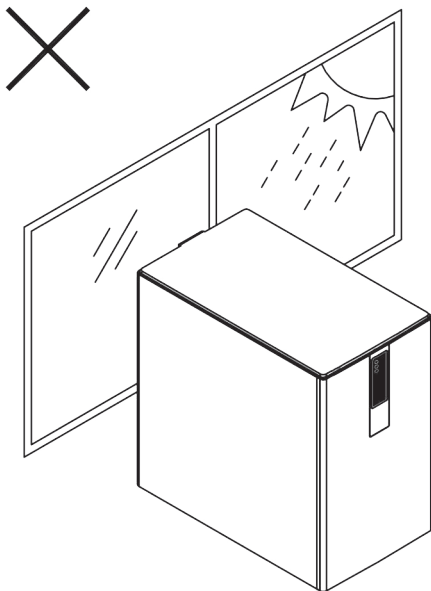

Keep the machine away from sunlight, heat, and wetness.

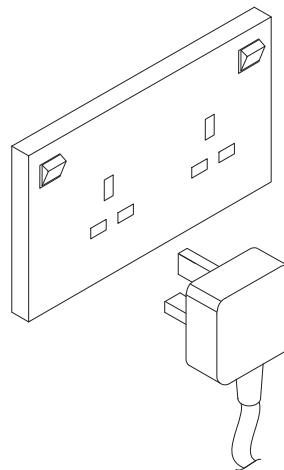

Be sure to use single outlet socket with correct power voltage. Plug the power cord directly into electrical socket.

## Plumbing connections

 Valves and fittings must be sealed with PTFE tape if compression seals are not included.

 Use Wholesome (cat1) water supply  
Water supply pressure range 2 - 4 bar

1. Connect the appliance via a T-piece and isolation (ball valve), see drawing (A).

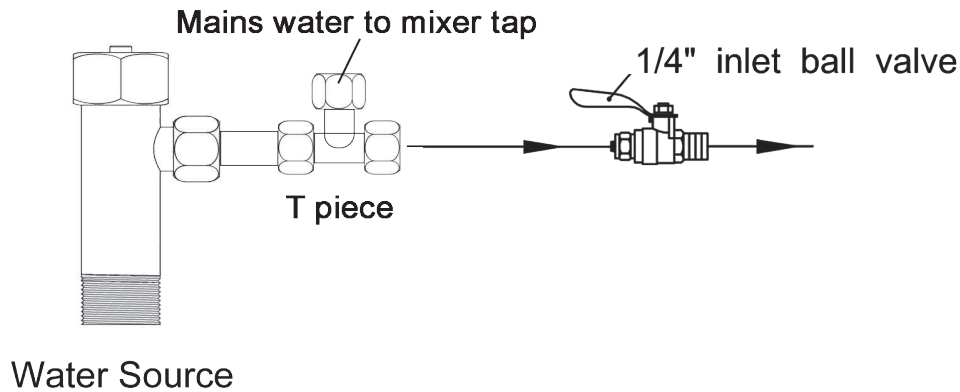

drawing ( A )

2. Connect the 1/4" PE water pipe between the ball valve and the appliance, via the filter, see drawing (B) below.

3. The water inlet connection is at the bottom rear of the appliance, see adjacent.

### Water inlet position

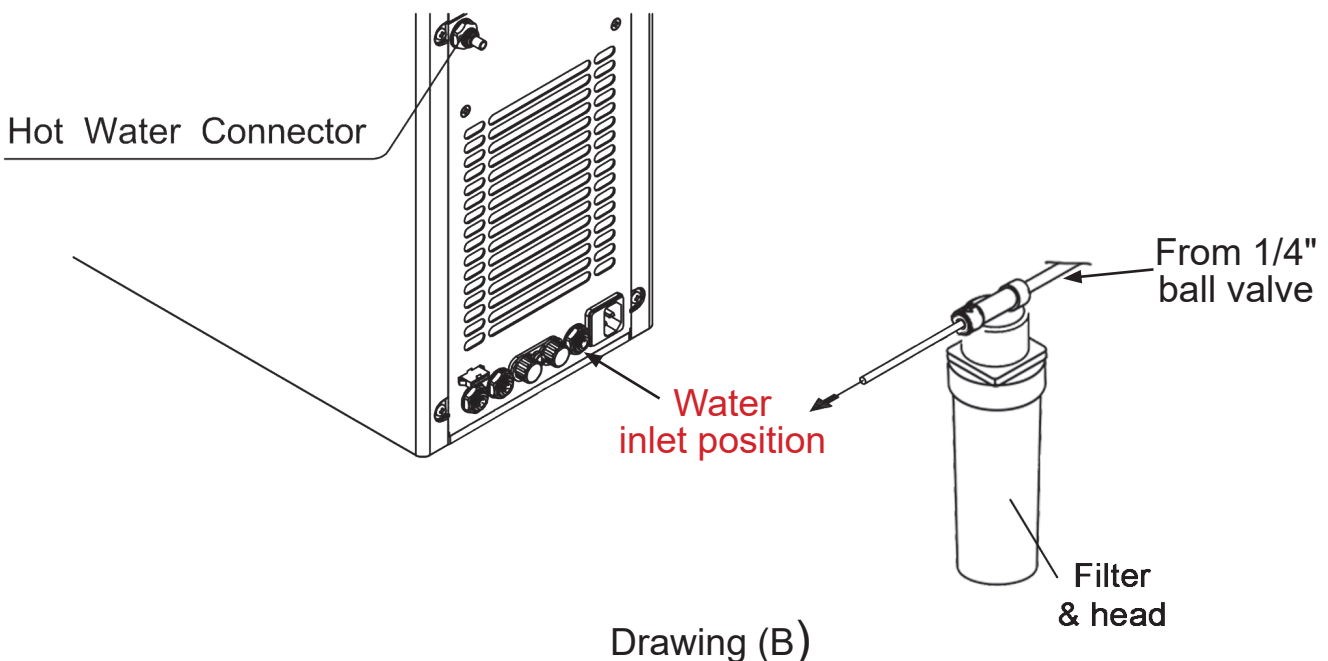
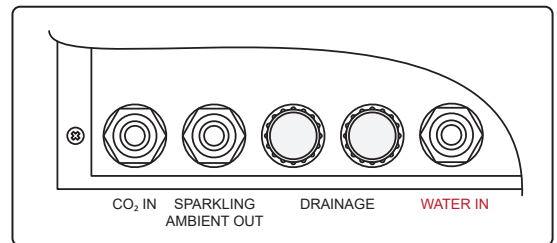

Drawing (B)

## CO<sub>2</sub> connections



Be aware of the risks of hazards which could cause harm when handling compressed CO<sub>2</sub>.

Read the safety instructions at the start of this instruction manual.

Assess the risks before starting the installation.

1. Prepare a pressure regulator, adapter and CO<sub>2</sub> bottle.

2. Connect the pressure regulator to the CO<sub>2</sub> bottle with the adapter.

3. Connect the pressure regulator to the under counter appliance with the CO<sub>2</sub> braided hose supplied, see arrangement below. The CO<sub>2</sub> inlet connection is at the bottom rear of the appliance, see adjacent (middle diagram).

4. Secure the CO<sub>2</sub> bottle with the strap provided.

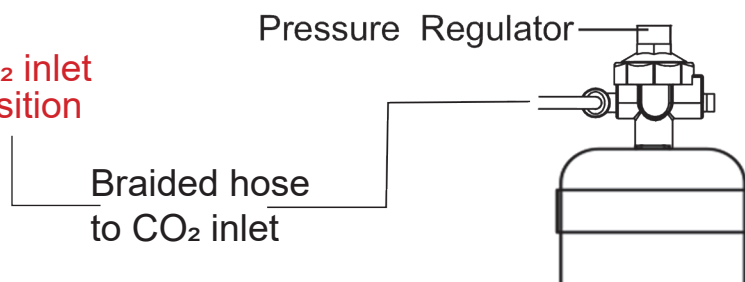
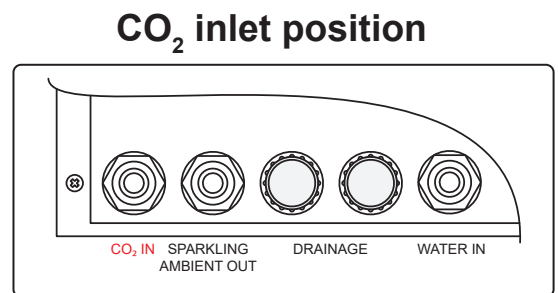
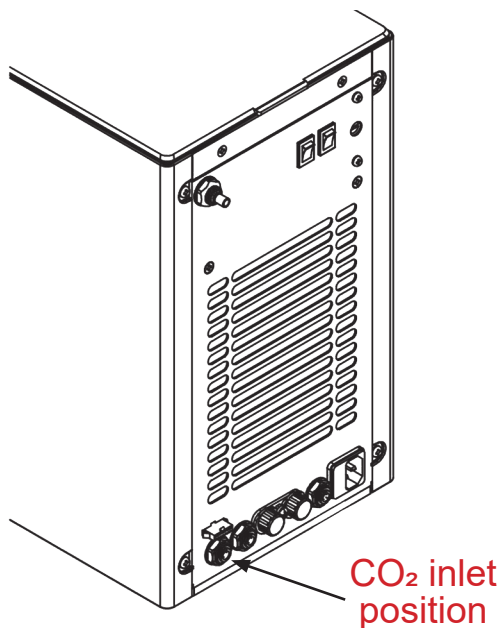
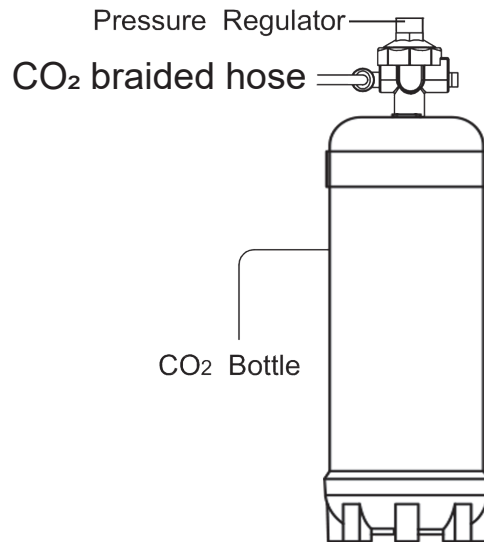

## Connect the system together

5. Please turn off power supply and water source before piping installation, then connect hot and ambient inlet water metal pipe with hot water source and ambient water source. Connect  $\phi 8\text{mm}$  drinking water inlet pipe and three way valve to water dispenser as marked in below image. Finally, connect the connection cable with the connector on rear panel, and plug in the power cord.

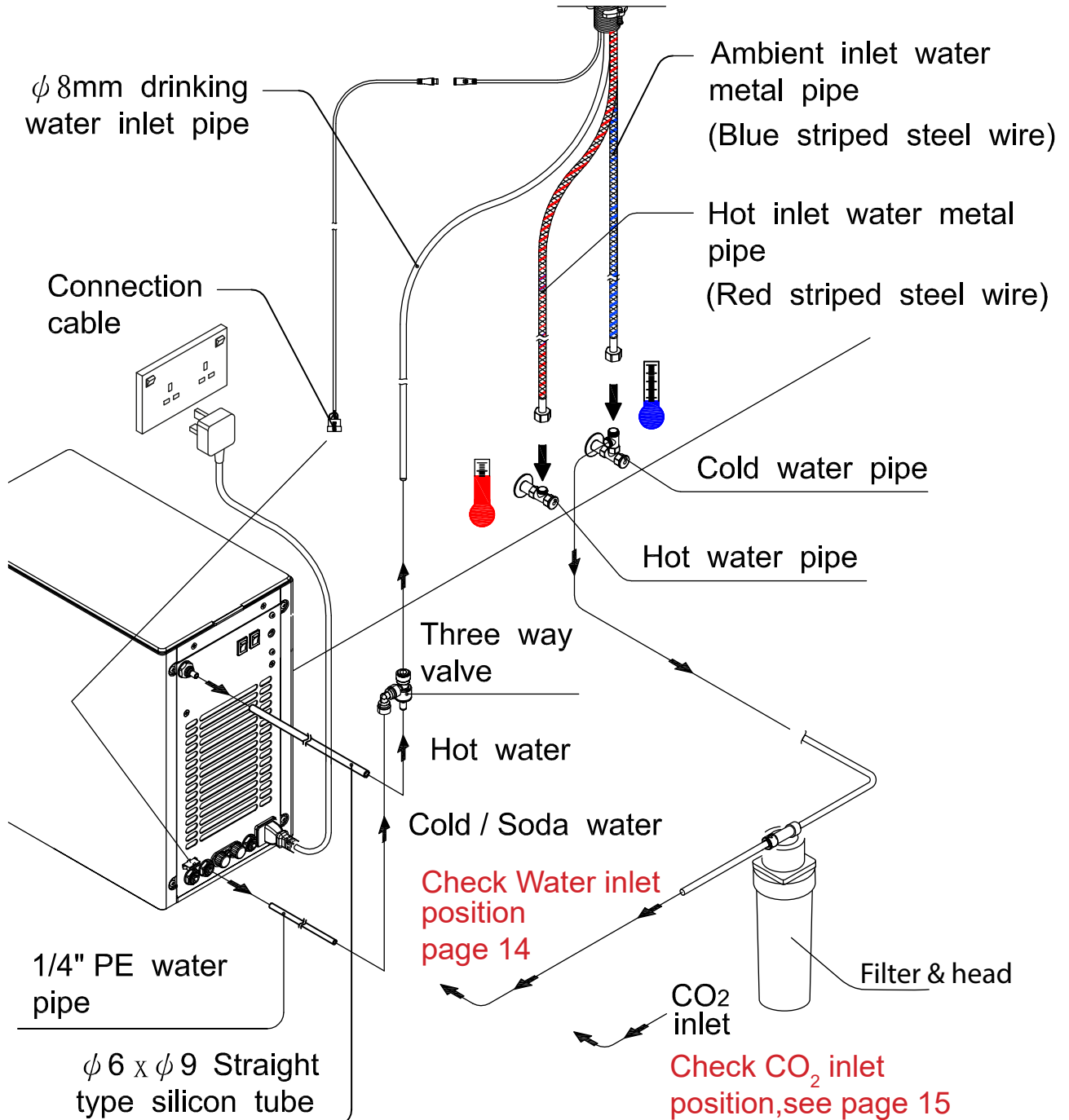



## Set up the chilled water system and flush the filter

1. Ensure that the power switches on the rear panel are OFF.
2. Connect the appliance to the mains electrical power supply.
3. Turn on the mains water isolation valve.
4. See page 22 for tap operation.
5. Dispense 10 litres of chilled water to flush the filter, to ensure best quality drinking water.
6. Rotate and hold the dispense control to the chilled water position until water is dispensed, it make take 1 - 2 mins.

Boiling chilled and sparkling water power switches

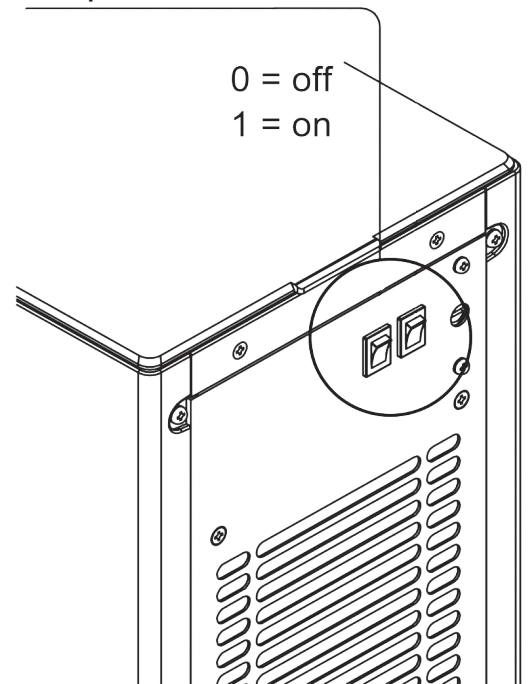

## Set up the chilled water system

7. Switch ON the chilled water power switch at the back of the appliance, to start the chilling cycle.
8. It takes up to 40 mins. to cool the chilled water to the rated temperature.

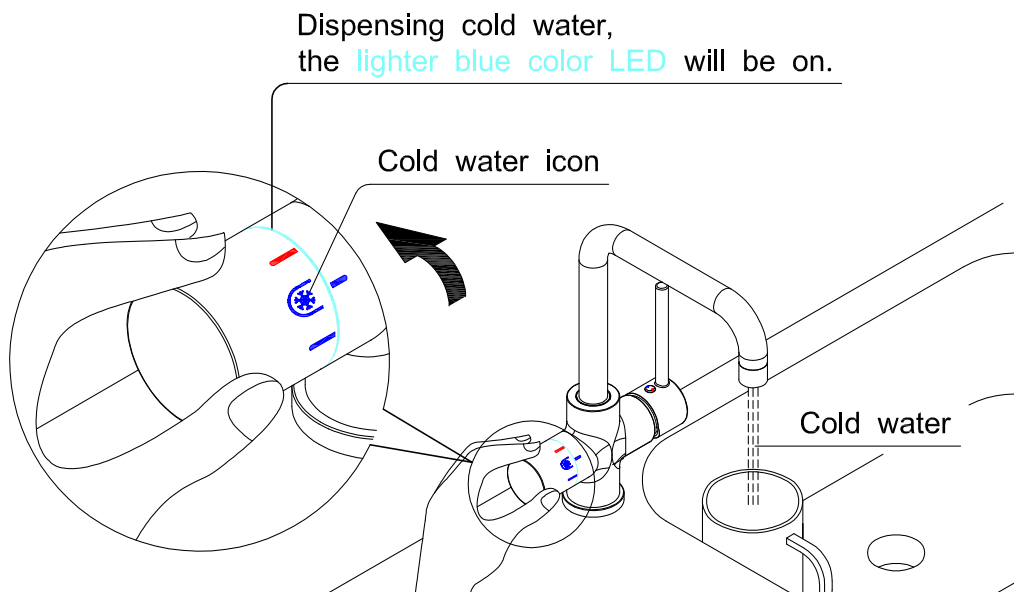

## Set up the sparkling water system

1. Ensure that the power switches on the rear panel are OFF.
2. See page 22 for tap operation.
3. Dispense 10 litres of chilled water to flush the filter, to ensure best quality drinking water.
4. Switch ON the sparkling water power switch at the back of the appliance, to start the sparkling water chilling cycle.
5. It takes up to 40 mins. to cool the chilled water to the rated temperature.
6. Sparkling water is ready to be dispensed.

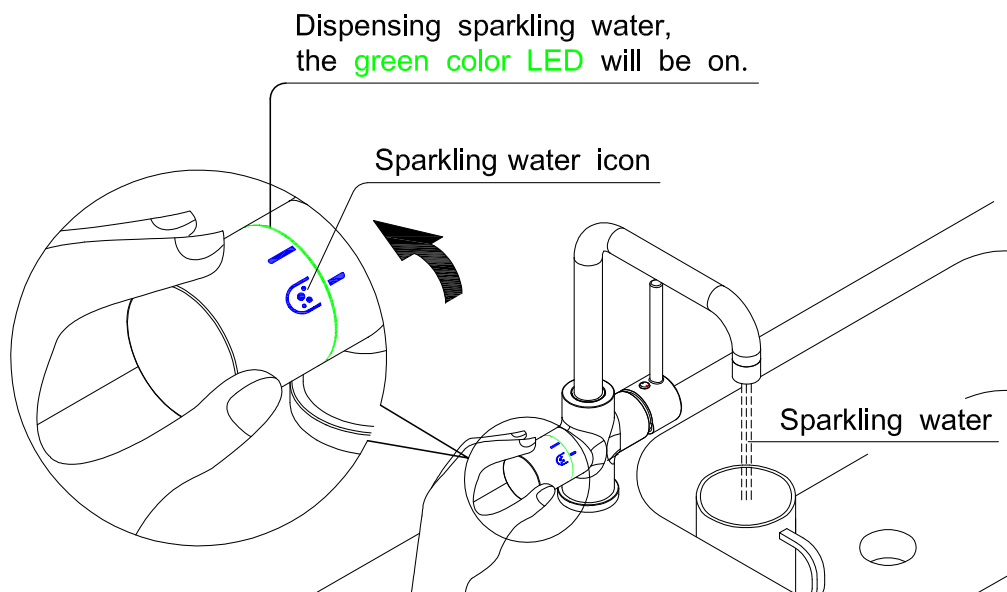

## Set up the boiling water system



**IMPORTANT** water must be dispensed from the boiling system before switching ON the Boiling water switch, to ensure that the heating element has been immersed

1. Ensure that the power switches on the rear panel are OFF (see page 17).
2. Rotate and hold the dispense control to the boiling water position to disable the safety lock. See page 22 for tap operation.
3. Then re-rotate to the boiling water position to dispense.
4. Switch ON the boiling water power switch at the back of the appliance, to start the boiling water cycle. (see page 17).

Please rotate again within 3 seconds when red LED light is blinking, then the red LED light will stop blinking and start to dispense hot water.

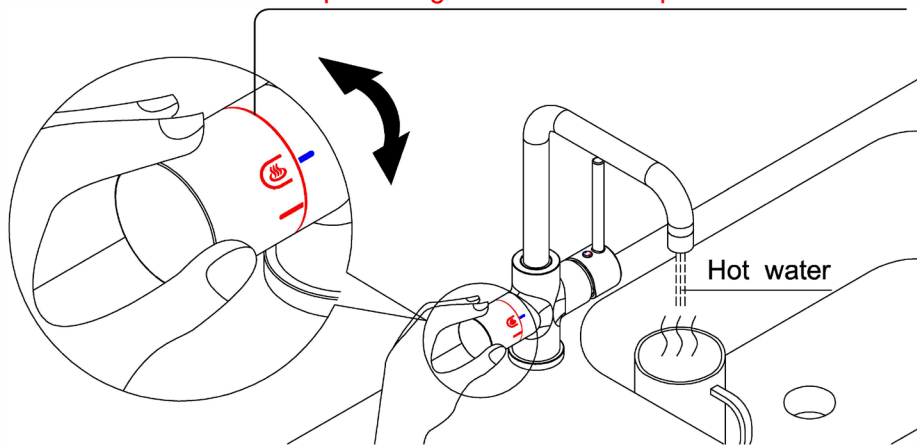

Rotate the controller to hot water icon, the red LED light will be blinking, this is to unlock the hot water, the hot water will not be dispensed.

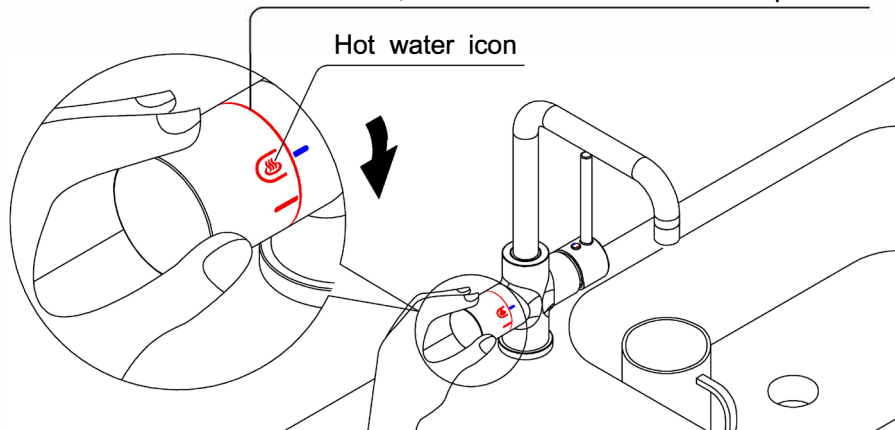

5. The water in the boiling tank begins to heat. It takes up to 10 mins. to heat the water to the boiling water set point.

## Adjust the boiling water set point

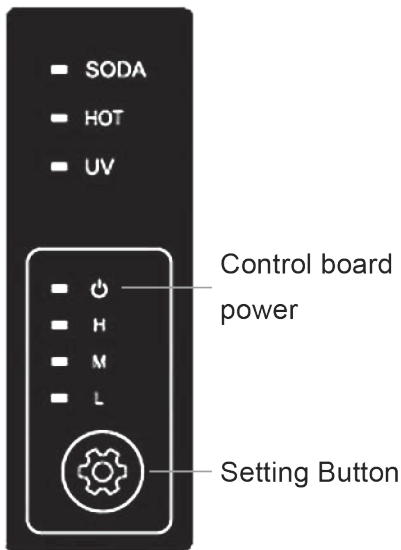

Indicator & setting

Base on the altitude differences, boiling point can be different to affect hot water dispensing.

The setting button on the panel may be used to change the maximum heating temperature of hot water according to the local geographic conditions to prevent over-boiling.

### To change the maximum heating temperature:

1. Press setting button once to enter setting mode.
2. Under setting mode, press setting button to change option. The selected option will be blinking.
3. Press and hold setting button for 2 seconds to save and change the selected option and complete the process. There is beep sound to remind user that setting process is completed.

H: Maximum temperature (98/96 celsius)

M: -2 degree from maximum temperature

L: -5 degree from maximum temperature.

Press and hold setting button for 5 seconds to shuts off the faucet function to prevent water from flowing while cleaning. Press button once again to enable faucet's dispensing function.

## How to dispense mixed water

1. There are two marks on the tap knob for cold and hot water. Blue color is ambient water and red color is hot water.

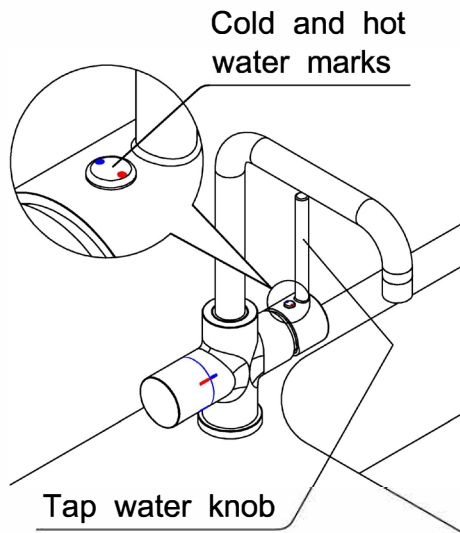

2. Hold tap knob and rotate, follow the arrow direction to choose hot or ambient water.

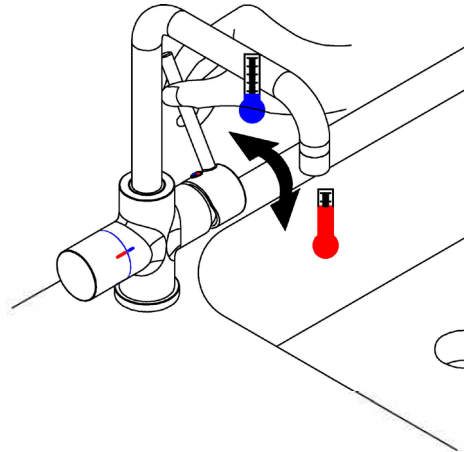



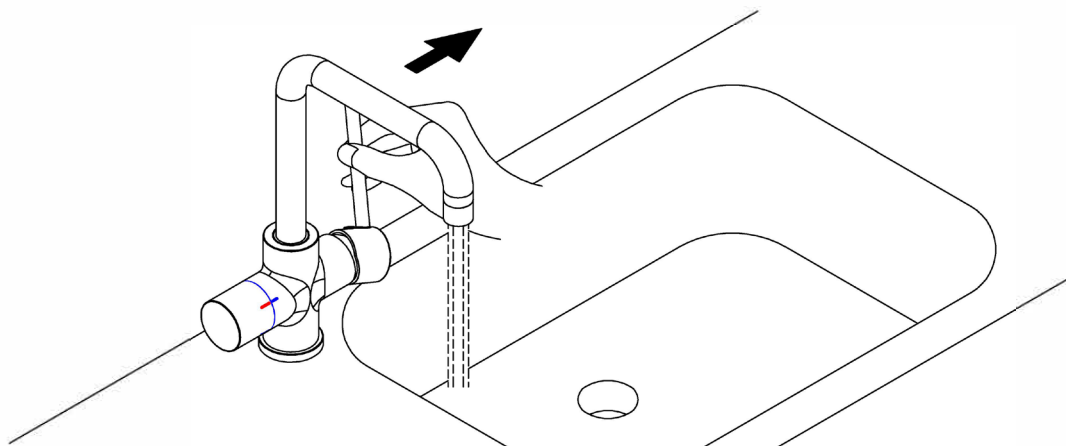



3. Pull the knob to right as arrow direction, the water will be dispensed.



## Boiling, chilled and sparkling functionality

There are three functions on the rotation controller and the icon of turning off the water supply.

-  Hot water icon
-  Stop dispensing icon
-  Cold water icon
-  Stop dispensing icon
-  Sparkling water icon
-  Warm water icon

Align the stop dispensing icon on the rotation controller with the stop dispensing icon on the tap body to stop dispensing water; the blue LED light will be on.

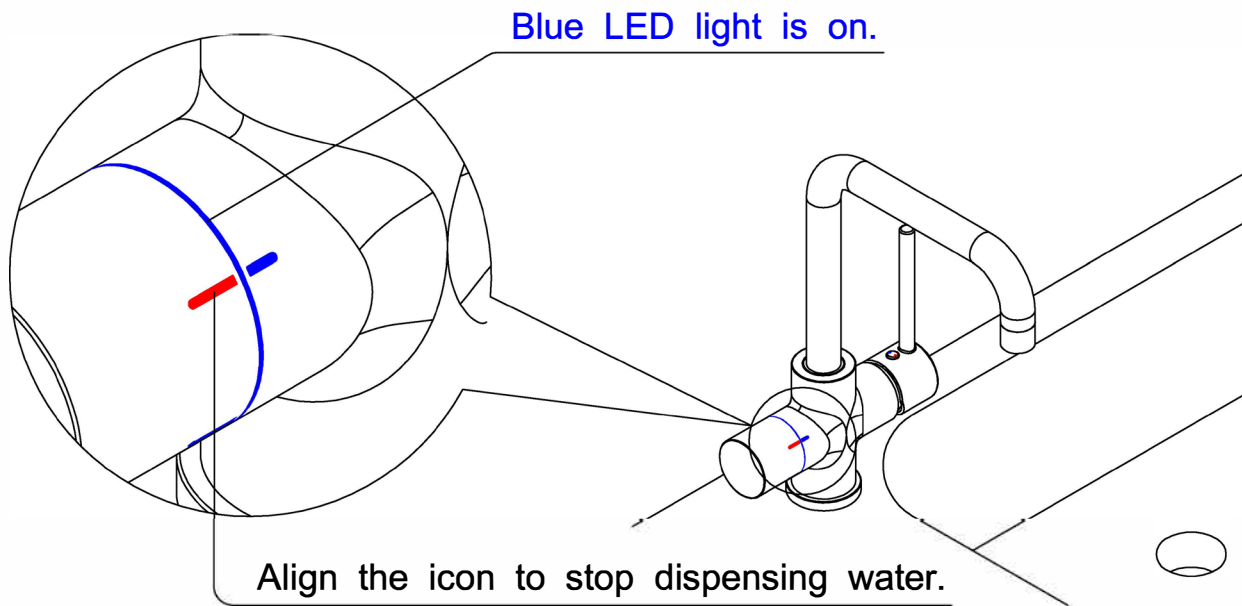

The LED light will be purple, when the water dispenser is heating hot water.

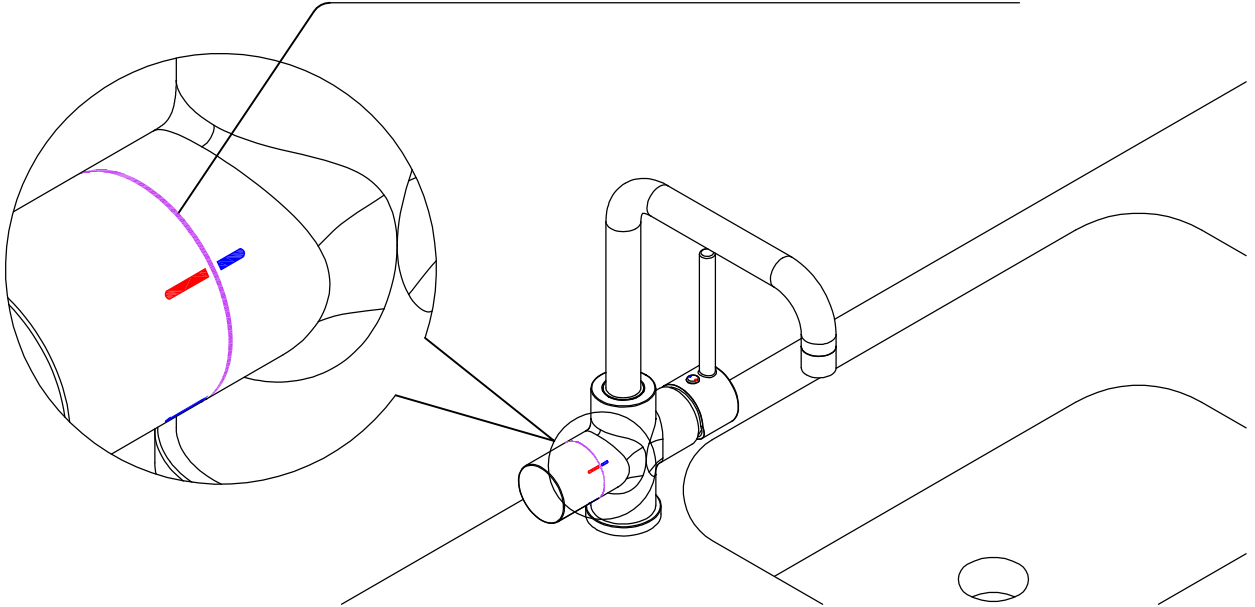

The LED light returns to blue color, when heating process is done.

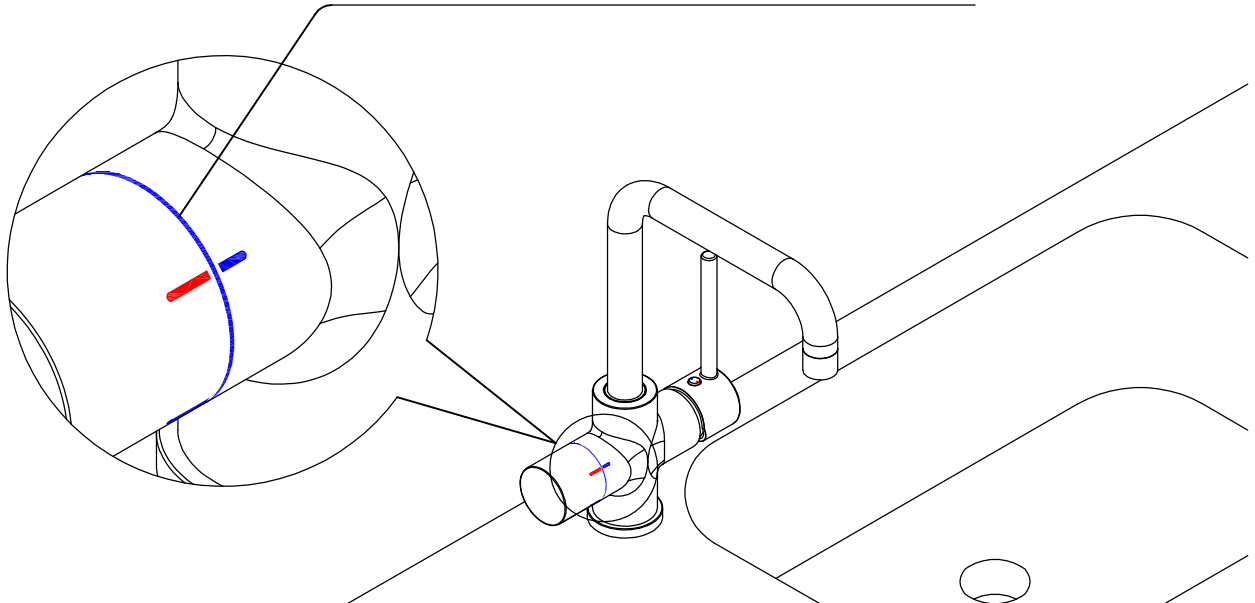

## Chilled water dispense

Dispensing cold water, the **lighter blue color LED** will be on.

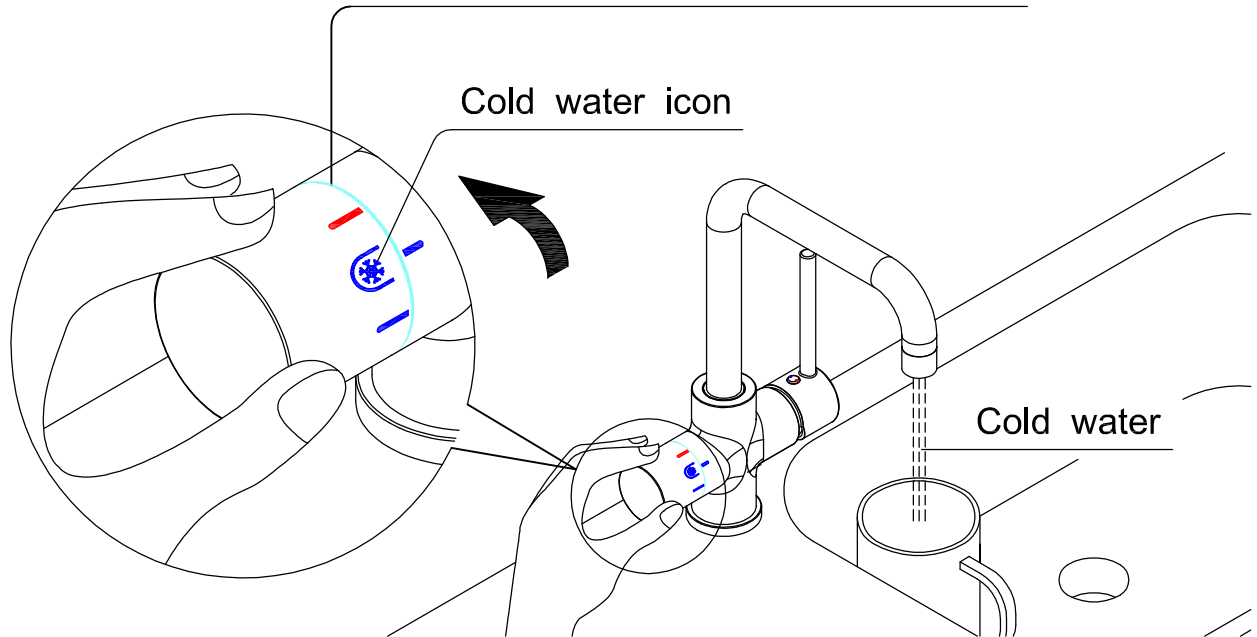

## Sparkling water dispense

Dispensing sparkling water, the **green color LED** will be on.

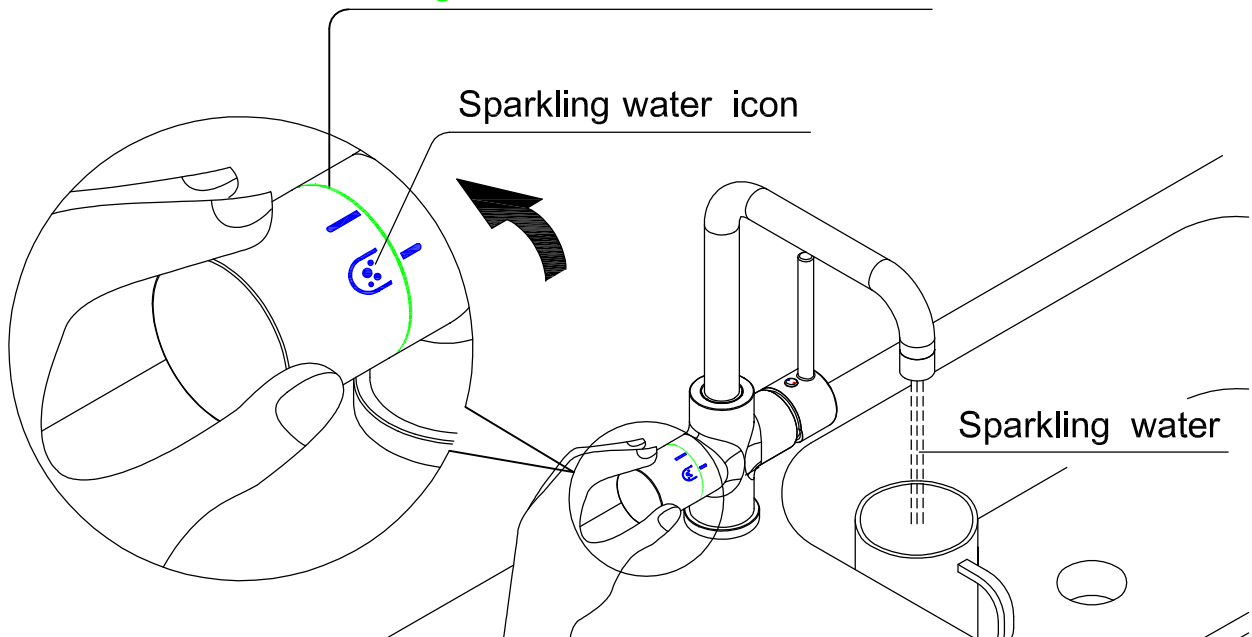



## Boiling water dispense

Rotate the controller to hot water icon, the red LED light will be blinking, this is to unlock the hot water, the hot water will not be dispensed.

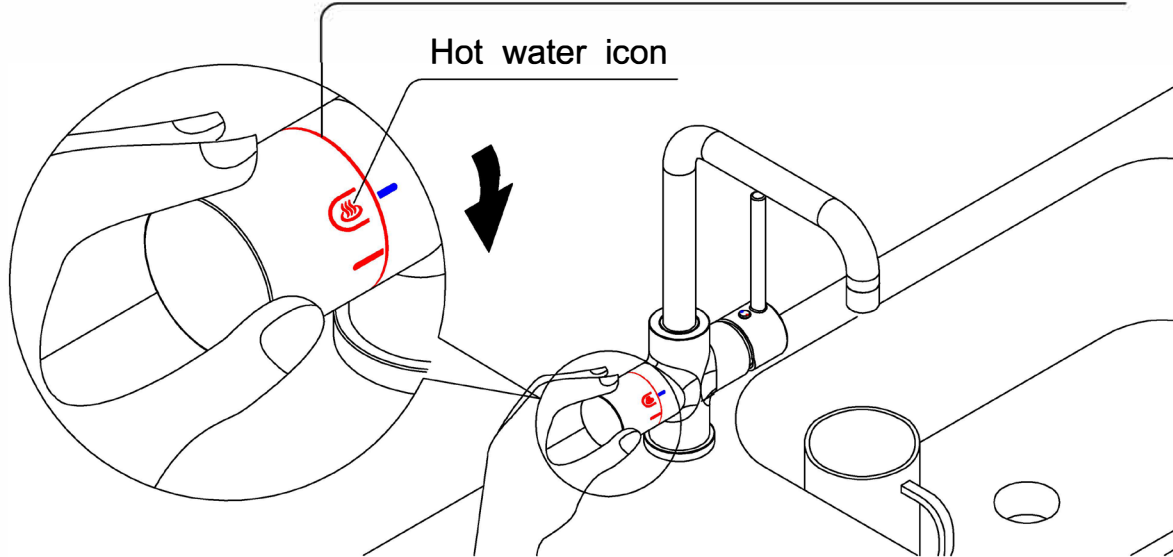

Please rotate again within 3 seconds when red LED light is blinking, then the red LED light will stop blinking and start to dispense hot water.

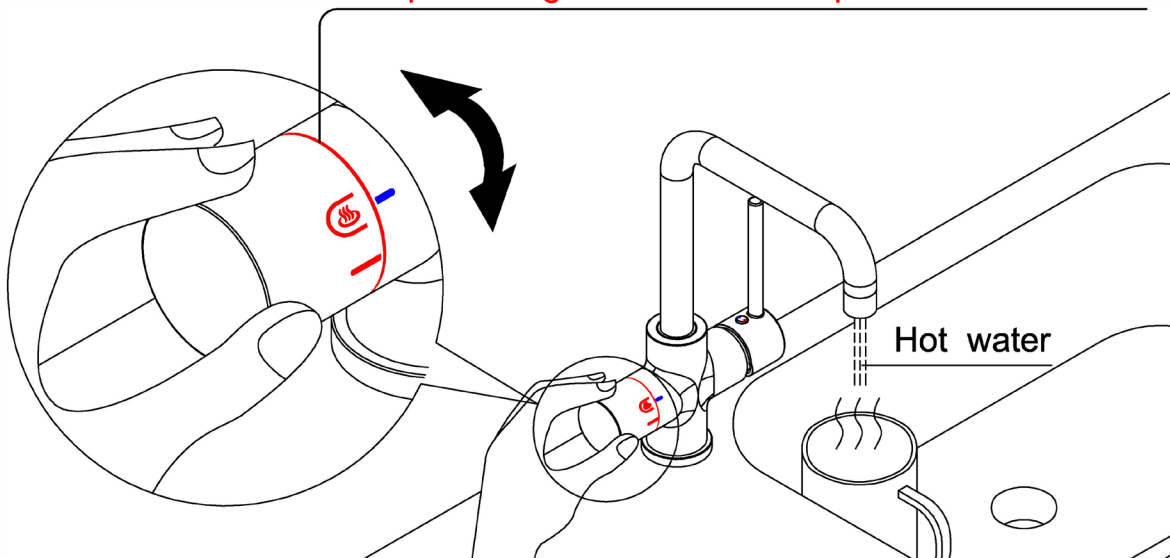

## Filter replacement



Not changing the filter cartridge when required may affect the water quality.

Sanitisation should be carried out at all filter changes, or at intervals of no more than 6 months.



Use instructions supplied with the filter cartridge.

1. Turn OFF the power supply to the appliances.
2. Turn OFF the mains water supply.
3. Remove the old filter (see below).
4. Be aware that some water may drip from the filter head.
5. Remove the sanitary cap from the new filter, do not touch the connector
6. Moisten the new filter connector with clean tap water.
7. Insert the new filter (see below).
8. Dispense 10 litres of chilled water to flush the filter.

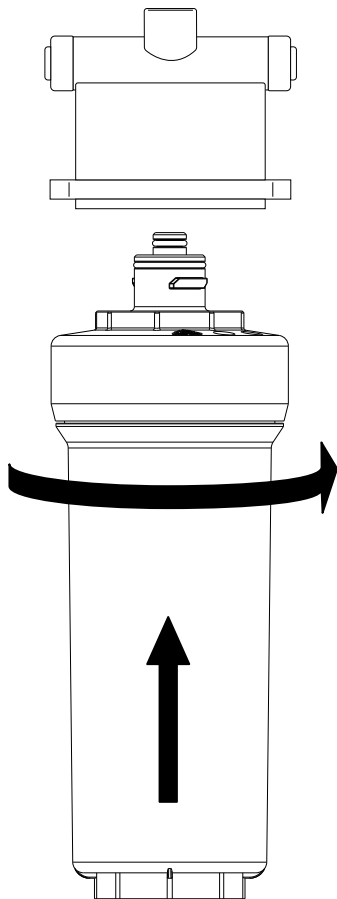

**Insert new filter**

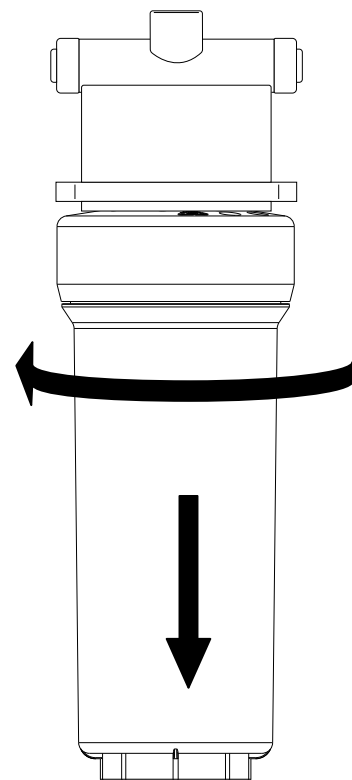

**Remove old filter**

# UV lamp replacement (recommended every 12 months)

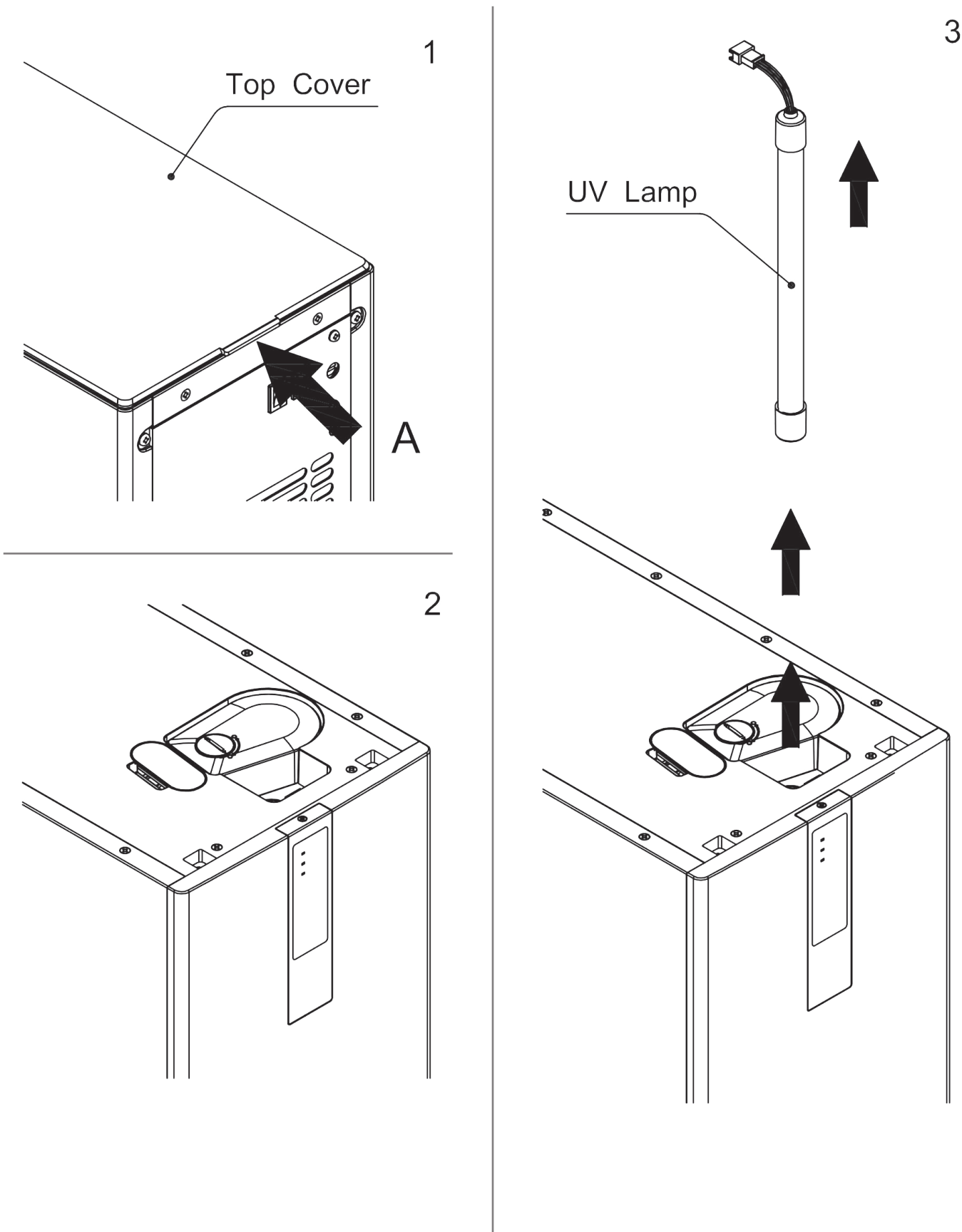

## Cleaning



- Wipe surfaces with a damp cloth or antibacterial alcohol wipes, then wipe dry with a clean, dry microfibre cloth or paper towel.
- Food-grade disinfection wipes may be used to clean around and within the tap spout.



### **IMPORTANT**

- Do not use strong, corrosive, or abrasive cleaning materials.
- Do not use air-drying disinfectant sprays.
- Failure to remove the cleaning liquid may damage the finish of the tap.

## Trouble shooting

Defection Status	Possible Defection Reason	Solution
Hot water is not hot	1. The hot power switch is off.	Turn the hot power switch on.
	2. Hot temperature protection is enabled due to dry-heat.	Call for service to reset the protection button on the hot tank.
	3. Problem with PCB or thermostat.	Please contact service people.
No hot water	1. No water from mains water supply.	Check inlet water supply.
	2. Inlet water pressure is too low.	Check inlet water pressure from pre-filtration system or water supply.
	3. Water is not being filling into hot tank.	Please press hot water button to fill water into hot tank until water comes out.
Cold water is not cold	1. The cold power switch at back is off	Turn the cold power switch on.
	2. Chilling time is not enough.	Please wait 40 minutes for water chilling.
	3. Refrigerant leaks.	Contact service people.
No cold water	1. No water from mains water supply.	Check inlet water supply.
	2. Cold water is being filling into cold tank.	Contact the service people.
	3. Inlet water pressure is too low.	Check inlet water pressure from pre-filtration system or water supply.
	4. Water in cold water tank got frozen.	Unplug the power cord then wait for 4 – 8 hours. Internal pipe may be broken please contact service people as well.
No sparkling water	1. CO <sub>2</sub> runs out.	Replace a new CO <sub>2</sub> Cylinder.
	2. The soda power switch at back is off.	Turn the soda power switch on.
	3. Water is unable to be filled to sparkling water tank.	Contact the service people.

## Trouble shooting

Defection Status	Possible Defection Reason	Solution
Hot water is dripping from dispensing nozzle.	1. Inlet water pressure is too low.	Check inlet water pressure from pre-filtration system or water supply.
	2. The solenoid valve got malfunction.	Contact service people.
Sparkling water is dripping from dispensing nozzle.	1. The remaining sparkling water in pipe is flowing due to CO <sub>2</sub>	Wait for a few seconds, it will be stopped.
	2. The solenoid valve got malfunction.	Contact service people.
UV indicator light is blinking and hearing beeps when dispensing water.	1. UV lamp is failure or no UV lamp is connected	Replace a UV lamp or check if the UV wire is disconnected.
	2. UV board is failure.	Contact service people.
All dispensing buttons are blinking and hearing beeps when press button.	1. There is leakage detected inside of water dispenser.	Unplug the power cord, then dry water on the internal base or ask for service.
	2. The waste water container is full.	Please drain all water from waste water container.
Bubble of sparkling water is insufficient.	1. The CO <sub>2</sub> and water doesn't mixed properly.	Please wait more time.
	2. CO <sub>2</sub> almost runs out.	Replace CO <sub>2</sub> cylinder
	3. CO <sub>2</sub> output pressure is too low.	Please adjust output pressure to 4 bar as suggestion.



# fohen

Fohen UK  
Trafalgar House  
Rash's Green  
Dereham  
Norfolk  
NR19 1JG

0808 196 2480  
hello@fohen.co.uk  
[www.fohen.co.uk](http://www.fohen.co.uk)

