

Fahrenheit

Technical Specification

98°C Boiling Tank

Element	Specification
Boiler Height (mm)	315
Boiler Width (mm)	210
Boiler Depth (mm)	210
Boiler Weight (Kg)	5.8
Boiler Capacity (L)	2.4
Temperature Control	75°C - 98°C
Construction Material	Stainless Steel / Glass
Heating Up Time	20 Minutes
Rated Input (kw)	1.5
Standby Power (W)	2.2
Rated Voltage (V)	220 - 240
Operating Pressure	1.5 - 5.0 Bar
Plug Type	Fused 13A 3 Pin Plug
Power Cord Length (mm)	910
Function Type	Touch Screen Digital Control

Carbon Purity Filter

Element	Specification
Replacement Cycle	6 Months
PE Tube Length (mm)	1000
Fittings Included	Yes
Rated Water Capacity	3.5 l/m
Connection 1	1/2" BSP Male & PE Tube Adaptor
Connection 2	1/2" BSP Female & PE Tube Adaptor

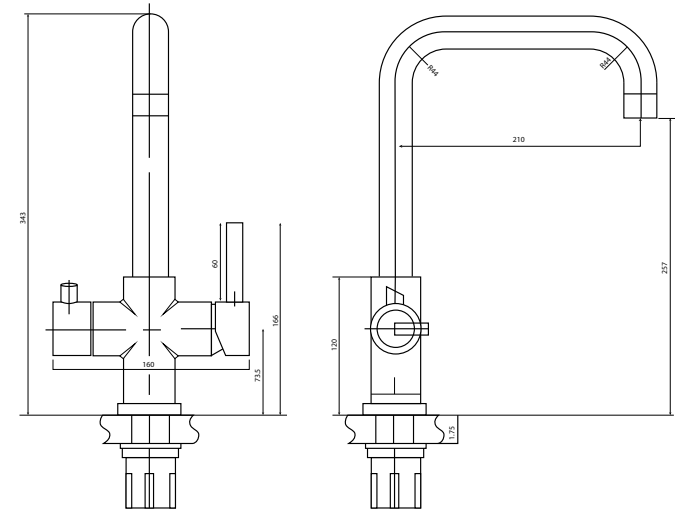

Fahrenheit Boiling Water Tap

Element	Specification
Range	Fahrenheit
Colour Finish Options	12
Tap Height (mm)	343
Spout Projection (mm)	210
Product Weight (Kg)	2.33
Construction Material	Brass
Installation Type	Deck Mounted
Flow Rate	2 Litres Per Minute
Child Safety	Spring Lock Mechanism
Cartridge Type	35mm Cartridge
Thermostat Cartridge Type	18mm Cartridge
Flow Type	Tri Flow
Handle Type	Lever
Swivel Spout	Yes
Tap Tails Included	Yes
Inlet Connection	1/2" BSP Flexible Tails
Worktop Hole	Ø 35mm