

# General Instructions

Please retain product label and instructions for future reference

**03DTSHAX0608FGD4MW-V1**

**DIP TREATED SHIPLAP APEX 6X8 FULLY GLAZED DOUBLE DOOR 4 MEDIUM WINDOW**

## BEFORE YOU START PLEASE READ INSTRUCTIONS CAREFULLY

- Check the pack and make sure you have all the parts listed.
- When you are ready to start, make sure you have the right tools at hand (not supplied) including a Phillips screwdriver, Stanley knife, Wood saw, Step ladder, Hammer and a Drill with 2mm bit.
- Ensure there is plenty of space and a clean dry area for assembly.

## LOCATION FOR YOUR GARDEN BUILDING

A minimum of 60cm should be left around the perimeter of your garden building to allow access for maintenance, annual treatment and to allow air flow around the building.

Where possible you should avoid placing your garden building underneath large trees to prevent the tree causing damage to the building.

## TIMBER

As with all natural materials, timber can be affected during various weather conditions. For the duration of heavy or extended periods of rain, swelling of the wood panels may occur. Warping of the wood may also occur during excessive dry spells due to an interior moisture loss. Unfortunately, these processes cannot be avoided but can be helped. It is suggested that the outdoor building is sprayed with water during extended periods of warm sunshine and sheltered as much as possible during rain or snow.

Once your garden building has been installed it will need to be treated as soon as possible and annually to prevent the timber from deteriorating and to waterproof it. This is required to maintain the anti-rot guarantee.

Dip Treated buildings - Require a preservative treatment to protect against rot and decay and a waterproof treatment to prevent water ingress

Pressure Treated buildings - Require a waterproof treatment to prevent water ingress

Log Cabins - Are supplied untreated and require a preservative and waterproofing treatment.

## BUILDING A BASE

When thinking about where the building and base is going to be constructed:  
Ensure that there will be access to all sides for maintenance work and annual treatment.

Ensure the base is level and is built on firm ground, to prevent distortion. Refer to diagrams for the base dimensions, The base should be slightly smaller than the external measurement of the building, i.e. The cladding should overlap the base, creating a run off for water. It is also recommended that the floor be at least 25mm above the surrounding ground level to avoid flooding.

## TYPES OF BASE

- Concrete 75mm laid on top of 75mm hard-core.
- Slabs laid on 50mm of sharp sand.

*Whilst all products manufactured are made to the highest standards of Safety and in the case of childrens products independently tested to EN71 level, we cannot accept responsibility for your safety whilst erecting or using this product.*



x2

All buildings should be erected by two adults



Winter = High Moisture = Expansion  
Summer = Low Moisture = Contraction



2mm Drill bit

For ease of assembly, you **MUST** pilot drill all screw holes and ensure all screw heads are countersunk.



## CAUTION

Every effort has been made during the manufacturing process to eliminate the prospect of splinters on rough surfaces of the timber. You are strongly advised to wear gloves when working with or handling rough sawn timber.



For ease of assembly, you will need a tape measure to check dimensions of components.

Screws & Nails



Measure overall length

Bolts



Measure under the head

To identify the fixings required for each step use a measuring tape.

**\*\*Protim Aquatan T5 (621)\*\***

Your building has been dip treated with **Aquatan**.

Aquatan is a water-based concentrate which is diluted with water, the building has been treated by the correct application of Aquatan solution and then allowed to dry.

Aquatan is a decorative finish to colour the wood, which is applied industrially to timber fence panels and garden buildings.

**Aquatan undiluted contains:** boric acid, sodium hydroxide 32% solution, aqueous mixture of sodium dioctyl sulphosuccinat and alcohols: 2, 4, 6-trichlorophenol.



REGISTER FOR YOUR  
**ANTI-ROT**  
GUARANTEE TODAY

PLEASE SCAN HERE:



For assistance please contact customer care on: 01636 821215

**Mercia Garden Products Limited,**

**Sutton On Trent,**

**Newark,**

**Nottinghamshire,**

**NG23 6QN**

[www.merciagardenproducts.co.uk](http://www.merciagardenproducts.co.uk)



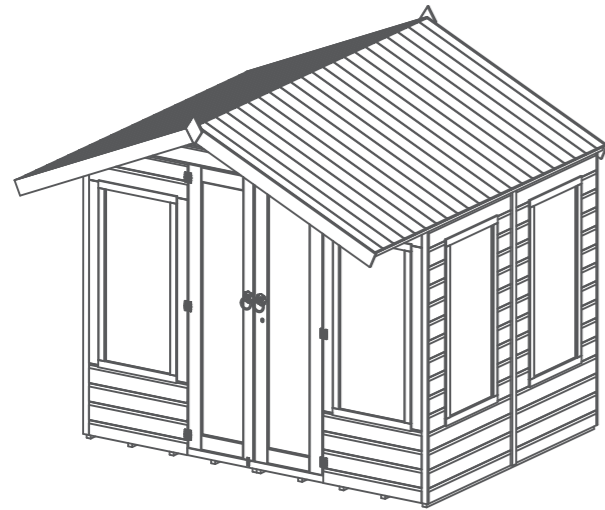

### 6x8 Summer House

**Pack Required:**  
03DTSHAX0608FGD4MW-V1 QTY 1

**Overall Dimensions:**  
Width = 2494mm  
Depth = 2457mm  
Height = 2344mm

**Base Dimensions:**  
Width = 2350mm  
Depth = 1753mm



### 6x8 Summer House with Veranda

**Pack Required:**  
03DTSHAX0608FGD4MW-V1 QTY 1  
03DTSHAX0208WCVPB-V1 QTY 1

**Overall Dimensions:**  
Width = 2494mm  
Depth = 2457mm  
Height = 2344mm

**Base Dimensions:**  
Width = 2350mm  
Depth = 2390mm

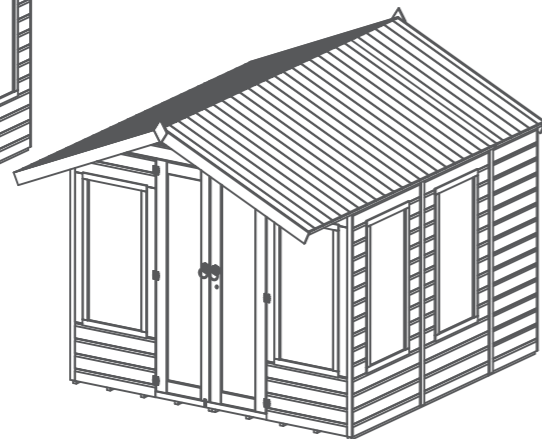
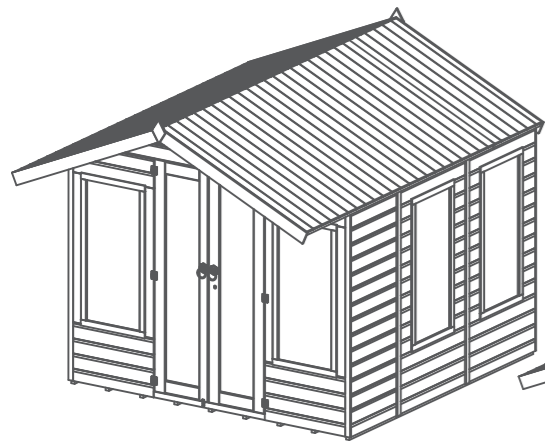

### 8x8 Summer House

**Pack Required:**  
03DTSHAX0608FGD4MW-V1 QTY 1  
03DTSHAX0208NWPB-V1 QTY 1

**Overall Dimensions:**  
Width = 2494mm  
Depth = 3057mm  
Height = 2344mm

**Base Dimensions:**  
Width = 2350mm  
Depth = 2353mm

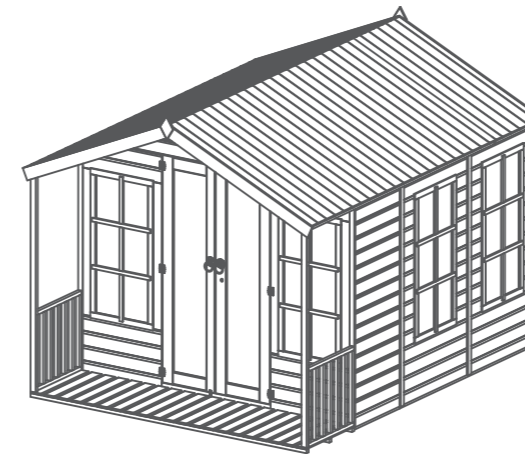

### 8x8 Summer House with Veranda

**Pack Required:**  
03DTSHAX0608FGD4MW-V1 QTY 1  
03DTSHAX0208NWPB-V1 QTY 1  
03DTSHAX0208WCVPB-V1 QTY 1

**Overall Dimensions:**  
Width = 2494mm  
Depth = 3057mm  
Height = 2344mm

**Base Dimensions:**  
Width = 2350mm  
Depth = 2990mm

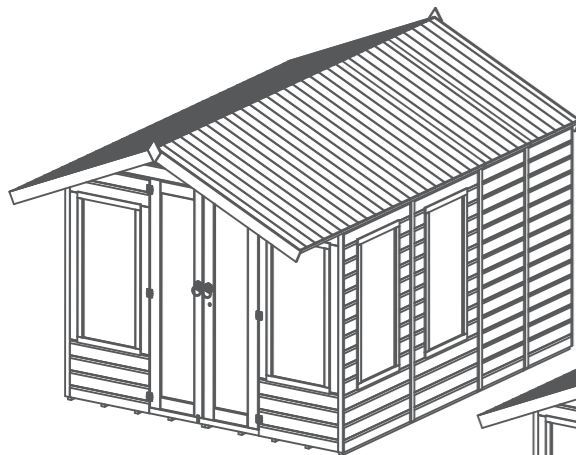

### 10x8 Summer House

**Pack Required:**  
03DTSHAX0608FGD4MW-V1 QTY 1  
03DTSHAX0208NWPB-V1 QTY 2

**Overall Dimensions:**  
Width = 2494mm  
Depth = 3657mm  
Height = 2344mm

**Base Dimensions:**  
Width = 2350mm  
Depth = 2953mm



### 10x8 Summer House with Veranda

**Pack Required:**  
03DTSHAX0608FGD4MW-V1 QTY 1  
03DTSHAX0208NWPB-V1 QTY 2  
03DTSHAX0208WCVPB-V1 QTY 1

**Overall Dimensions:**  
Width = 2494mm  
Depth = 3657mm  
Height = 2344mm

**Base Dimensions:**  
Width = 2350mm  
Depth = 3590mm

## Building Content - Pack A

03DTSHAX0608FGD4MW-V1

1

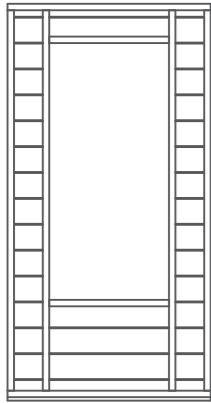

**Side Window Panel QTY 2**  
AI-03S11SH1SFWC879X1717-V1

2

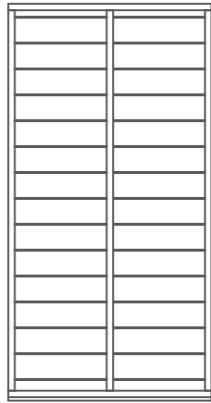

**Side Panel QTY 2**  
AI-S11SHPP879X1717-V1

3

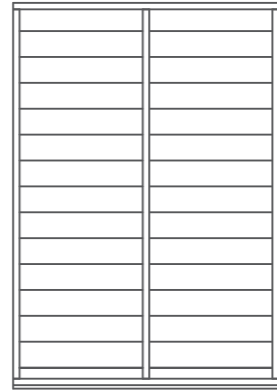

**Back Panel QTY 2**  
AI-S11SHPPPTF1150X1669-V1

4



**Window QTY 4**  
AI-FW540X1132-V1

5

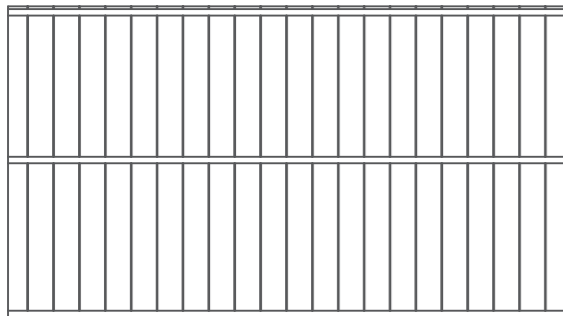

**Roof QTY 2**  
AI-S11MBAR2409X1345-V1

6

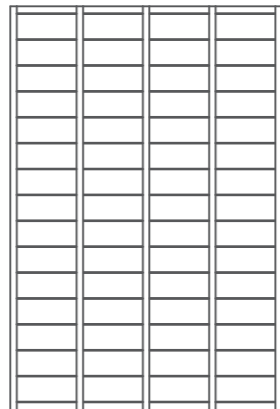

**Floor QTY 2**  
AI-R11MBF1175X1753-V1

7

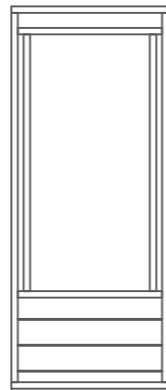

**Front Window Panel QTY 2**  
AI-03S11SH1SFWC680X1669-V1

8

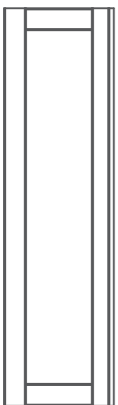

**Secondary Door QTY 1**  
AI-STDFGSD475X1715-V1

9



**Master Door QTY 1**  
AI-STDFGMD475X1715-V1

10



**Plain Gable Top QTY 1**  
AI-S11SHAGT2300X566-V1

11



**Door Gable Top QTY 1**  
AI-S11SHADDGT2300X566-V1

12



**Door Framing 28x28x940mm QTY 1**  
FS2828-940mm

13



**Gable Cover Trims 12x30x610mm QTY 4**  
S1230-610mm

14



**Cover Trims 12x40x1712mm QTY 7**  
S1240-1712mm

15



**Door Frame Strip 12x40x996mm QTY 1**  
S1240-996mm

16



**Door Frame Strip 12x40x1740mm QTY 2**  
S1240-1740mm

17



**Door Cover Trim 12x43x940mm QTY 1**  
S1243-940mm

18



**Fascia 12x95x1365mm QTY 4**  
S1295-1365mm

19



**Ridge Bar 27x70x1703mm QTY 1**  
F2770-1703mm

20

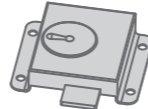

**Press Lock QTY 1**  
PI-07-0018

21



**Ring Pull QTY 2**  
PI-07-0032

22

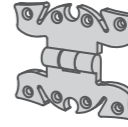

**Hinge QTY 6**  
PI-07-0004

23

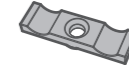

**Turn Button QTY 2**  
PI-07-0182

24

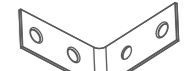

**Corner Brace QTY 2**  
PI-07-0012

25

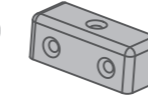

**Window Blocks QTY 16**  
PI-07-0011

26



**Shed Finial QTY 2**  
SHED DIAMOND FINIAL

27



**Felt**  
PI-01-0003

28

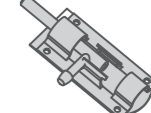

**Tower Bolt QTY 2**  
PI-07-0068

## Nail Bag

There may be extra screws present in the nail bag



60mm Screw x 10



30mm Black Screw x 48



50mm Screw x 71



20mm Black Screw x 22



40mm Screw x 19



Felt Tacks x 150



30mm Screw x 110

## Building Content - Pack B

03DTSHAX0208NWPB-V1

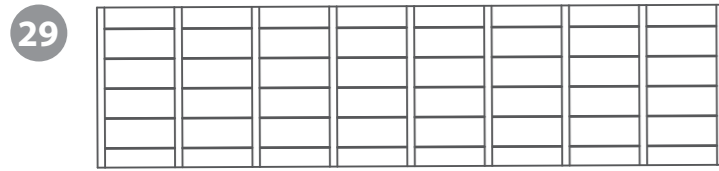

**Floor Extension QTY 1**  
AI-R11MBF2350X600-V1

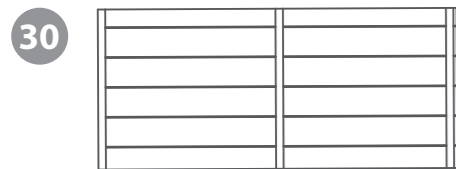

**Roof Extension QTY 2**  
AI-S11MBAR600X1345-V1

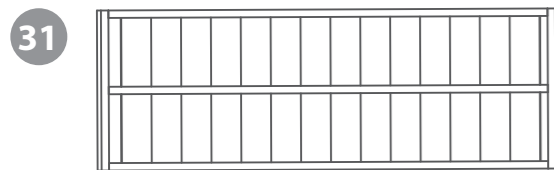

**Plain Panel Extension QTY 2**  
AI-S11SHPP600X1717-V1



**Cover Trims 12x40x1712mm QTY 2**  
S1240-1712mm

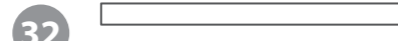

**32 Floor Blocks QTY 8**  
F2828-400mm



**33 Ridge Bar 27x70x599mm QTY 1**  
F2770-599mm

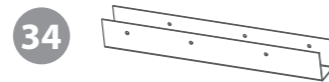

**34 U Channel QTY 3**  
PI-07-0031

## Nail Bag

There may be extra screws present in the nail bag

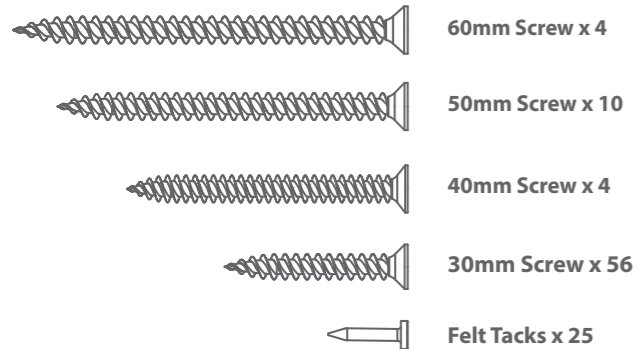

If 2ft Extension Pack has been purchased,  
Please follow Steps labelled **2ft EXTENSION**  
**PACK** where present

## Building Content - Pack C

03DTSHAX0208WCVPB-V1

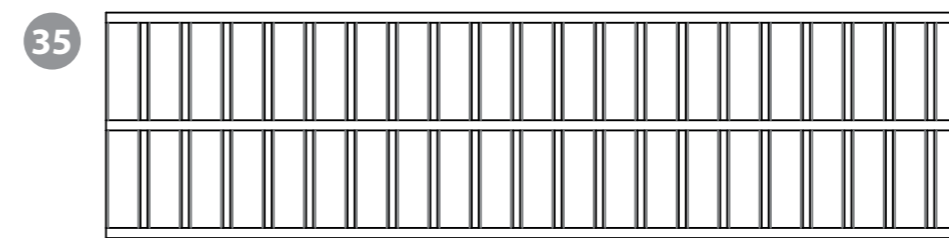

**Veranda Floor QTY 1**  
AI-R11STVF2380X622-V1

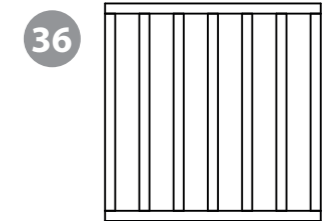

**36 Rail QTY 2**  
AI-03FR600X595-V1



**37 Roof Support - 27x44x1719mm QTY 2**  
F2744-G-1739mm

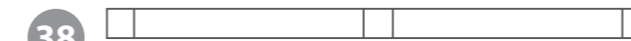

**38 Window Cross A - 16x27x500mm QTY 8**  
WC1627-500mm



**39 Window Cross B - 16x27x1094mm QTY 4**  
WC1627-1094mm

## Nail Bag

There may be extra screws present in the nail bag

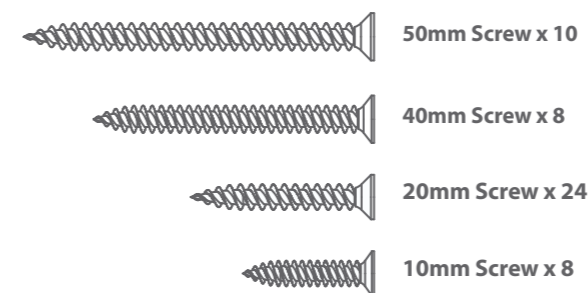

## Pre Assembly

Before assembling remove the transportation blocks from the bottom of each panel.

Take care removing the blocks as to not damage the panels. Tap with a flat headed screwdriver and hammer.

Dispose of the blocks once removed

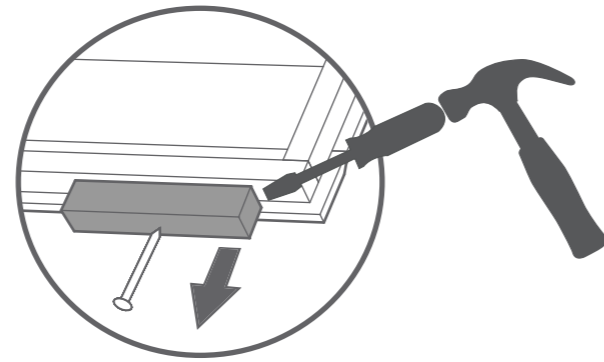

## 2ft EXTENSION PACK

### Step 1a

- Parts needed - No. 6 QTY 2  
 - No. 29 QTY 1  
 - No. 32 QTY 8

Place the floor panels (No.6) onto a firm and level base. Ensure the base has suitable drainage, free from areas where standing water can collect.

Secure the floors together using 10x50mm screws through the floor bearers in an alternating pattern.

Fix the Floor Extension (No.27) to the assembled floors, Secure using Floor blocks with 4x30mm screws per Floor block

Ensure the floor blocks are equally spaced between the framing and equally spread across both floors

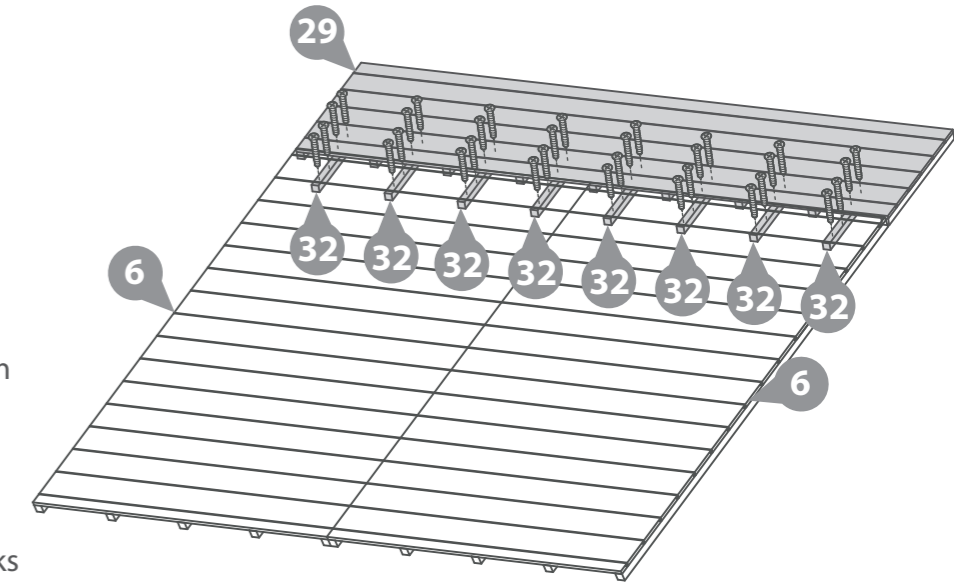

- 32x30mm Screws  
 10x50mm Screws

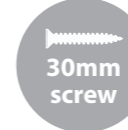

## Step 1

- Parts needed - No. 6 QTY 2

Place the floor panels (No.6) onto a firm and level base. Ensure the base has suitable drainage, free from areas where standing water can collect.

Secure the floors together using 10x50mm screws through the floor bearers in an alternating pattern.

- 10x50mm Screws

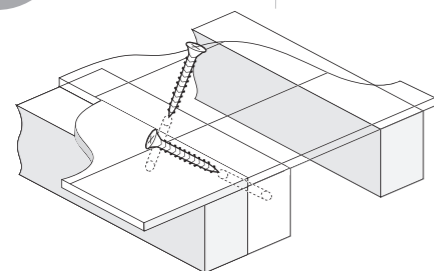

**IMPORTANT: Pre-drill before fixing screws.**

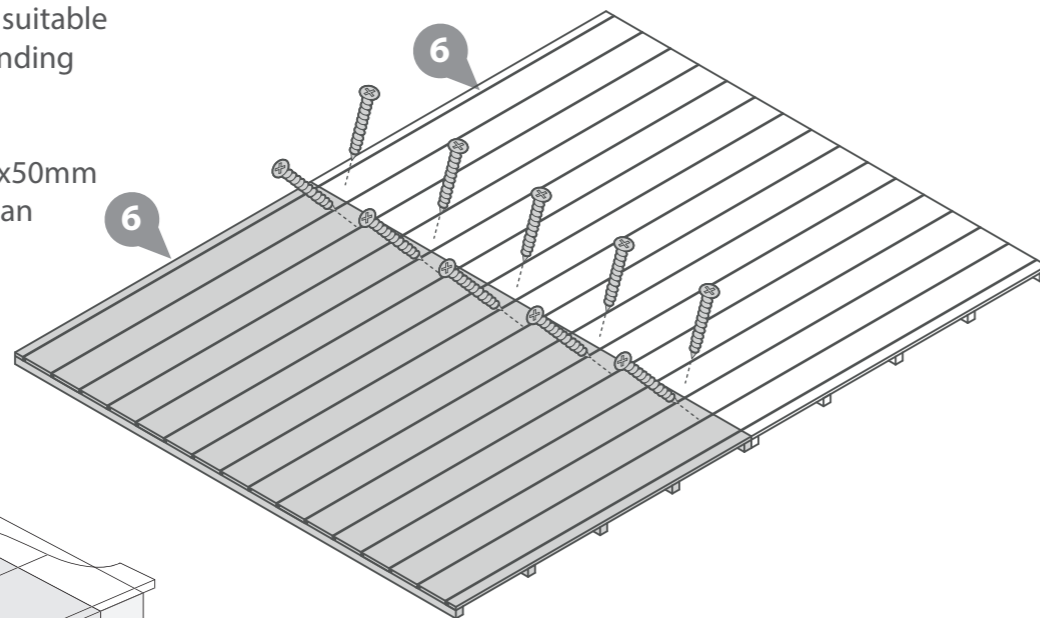

### 8x8 Summer House

- 32x30mm Screws  
 10x50mm Screws

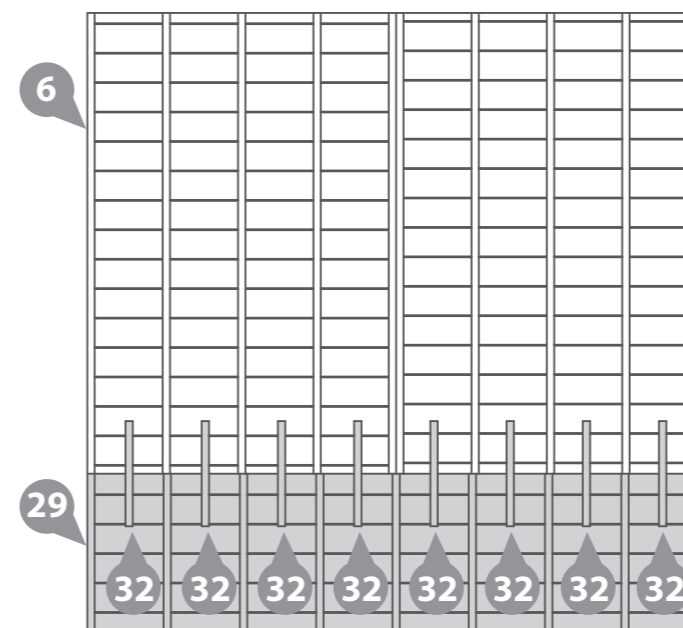

### 10x8 Summer House

- 64x30mm Screws  
 10x50mm Screws

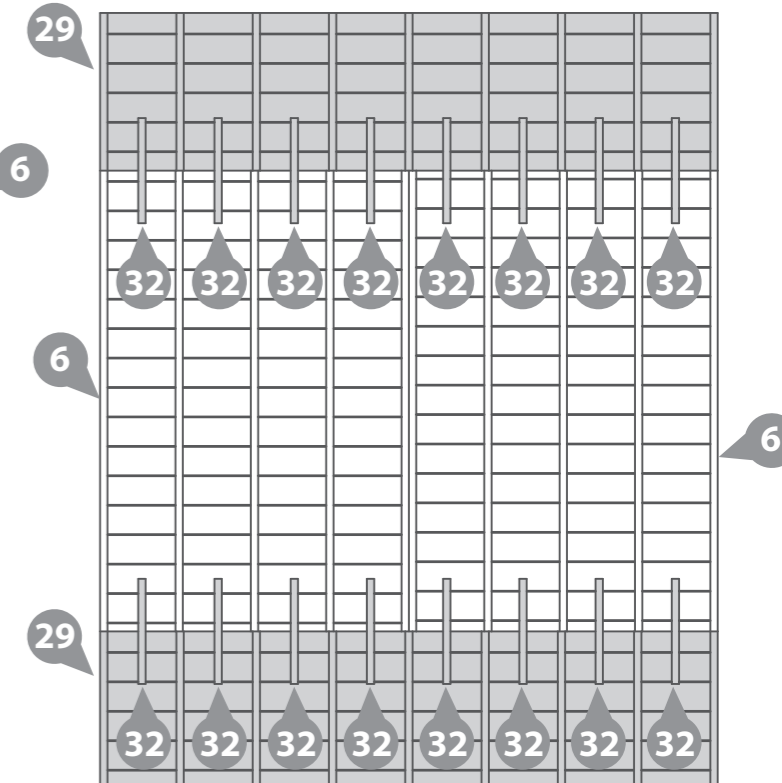

## Step 2

Parts Needed- No.2 QTY 1  
- No.3 QTY 1

Place the Side panel (No.2) and the Back Panel (No.3) onto the floor. Fix at the corner using 3x50mm screws.

**Do not secure the building to the floor until the roof has been fitted.**

Position the panels so there is equal spacing between the floor and cladding on all sides.

**The side panels should sit higher than then Back panels**



**Please note: The side panels are all interchangeable and can be positioned in a variety of configurations. Decide which works best before assembly**

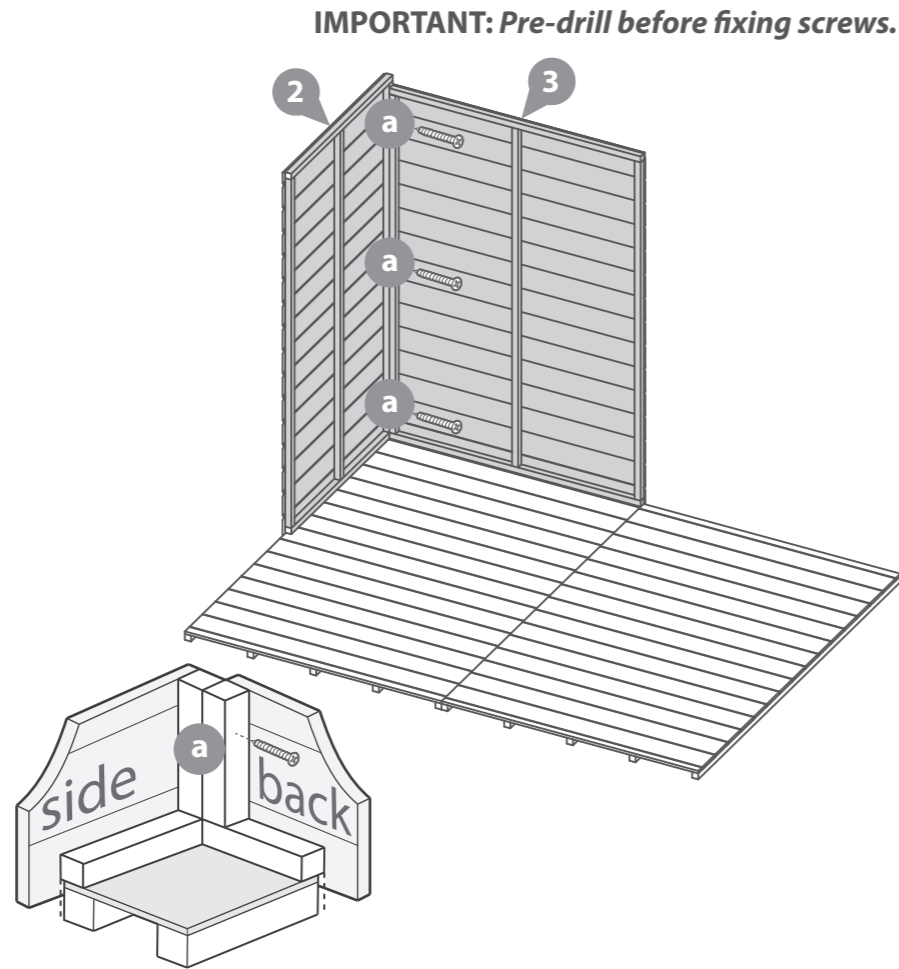

## Step 3

Parts Needed- No.2 QTY 1  
- No.3 QTY 1

Place the Side panel (No.2) and the Back Panel (No.3) along side the standing panels. Fix in an alternating pattern using 3x50mm screws per panel.

**Do not secure the building to the floor until the roof has been fitted.**

Position the panels so there is equal spacing between the floor and cladding on all sides.

6x50mm Screws



**Please note: The side panels are all interchangeable and can be positioned in a variety of configurations. Decide which works best before assembly**

**IMPORTANT: Pre-drill before fixing screws.**

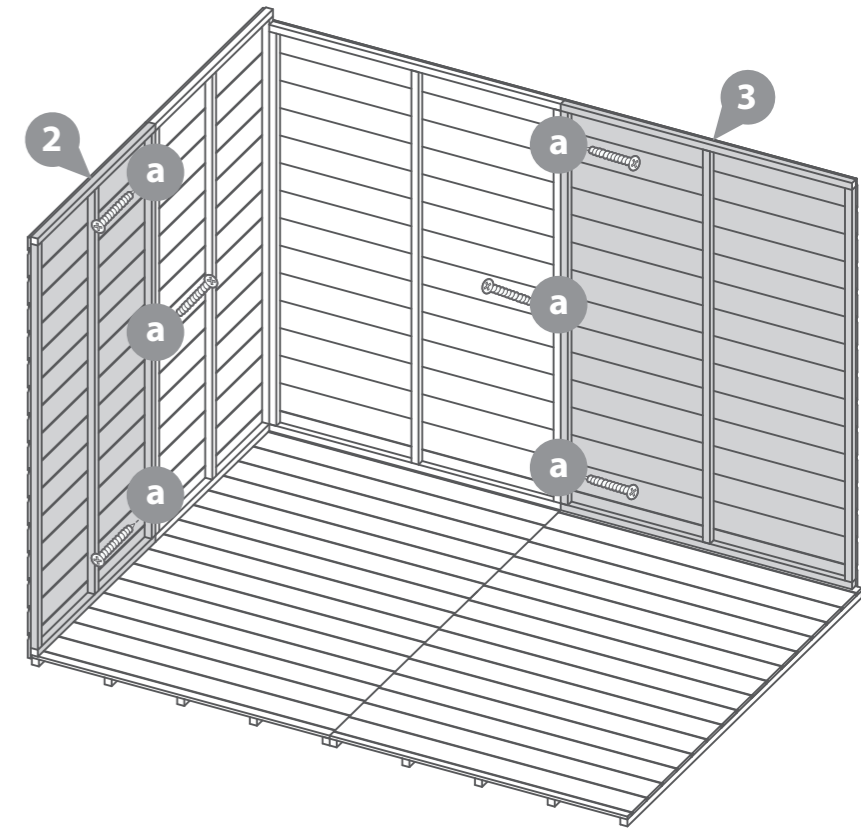

## 2ft EXTENSION PACK

### Step 2a

Parts Needed- No.2 QTY 1  
- No.3 QTY 1  
- No.31 QTY 1

Place the Plain panel Extension (No.31) and the Back Panel (No.3) onto the floor. Fix at the corner using 3x50mm screws.

Place the Side panel (No.2) onto the floor and fix along the side in alternating pattern using 3x50mm screws.

**Do not secure the building to the floor until the roof has been fitted.**

Position the panels so there is equal spacing between the floor and cladding on all sides.

**The side panels should sit higher than the Back panels**

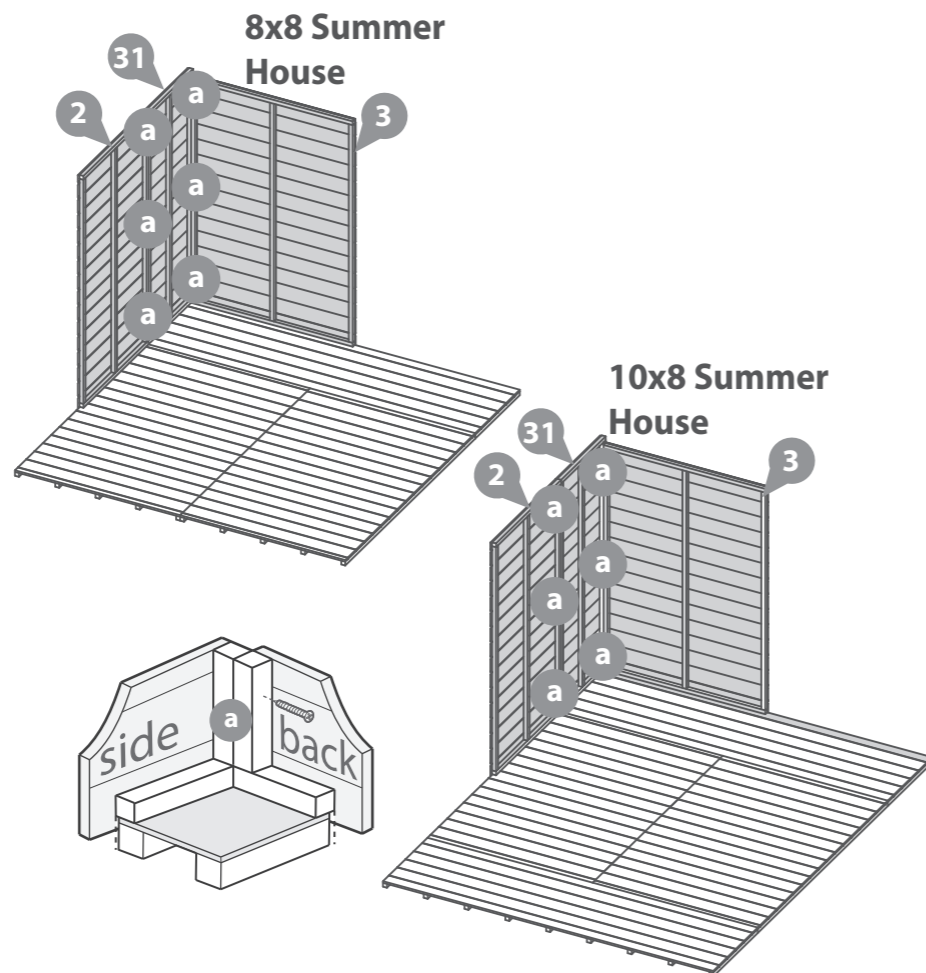

## 2ft EXTENSION PACK

### Step 3a

Parts Needed- No.2 QTY 1  
- No.3 QTY 1  
- No.31 QTY 1

Place the Back Panel (No.3) and the Side panel (No.2) onto the floor. Fix in an alternating pattern using 3x50mm screws per panel

Place the Plain panel Extension (No.31) onto the floor. Fix at the corner using 3x50mm screws

**Do not secure the building to the floor until the roof has been fitted.**

Position the panels so there is equal spacing between the floor and cladding on all sides.

**The side panels should sit higher than the Back panels**

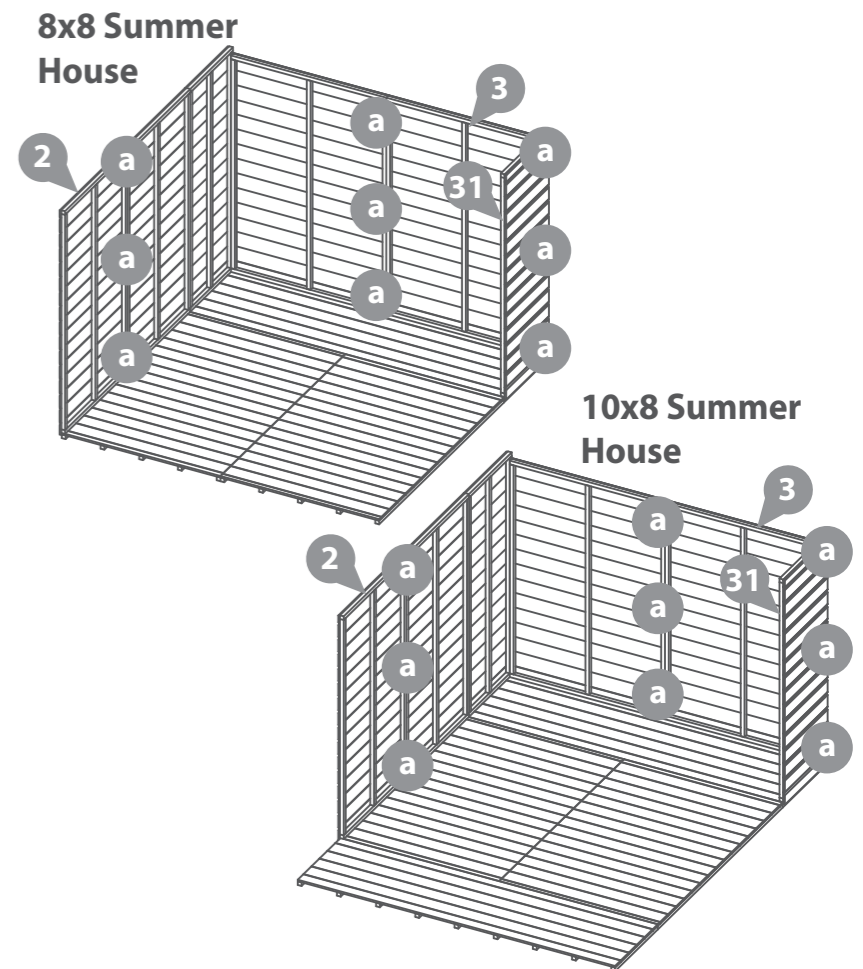

## Step 4

Parts Needed- No.1 QTY 2

Place the Side Window panels (No.1) onto the floor. Fix in an alternating pattern using 3x50mm screws per panel.

**Do not secure the building to the floor until the roof has been fitted.**

Position the panels so there is equal spacing between the floor and cladding on all sides.

6x50mm Screws

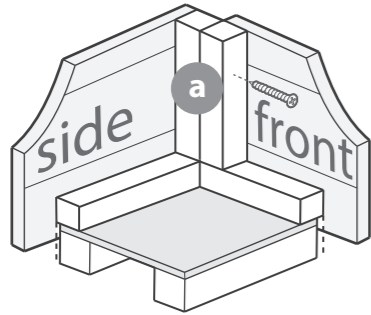

**Please note: The side panels are all interchangeable and can be positioned in a variety of configurations. Decide which works best before assembly**

**IMPORTANT: Pre-drill before fixing screws.**

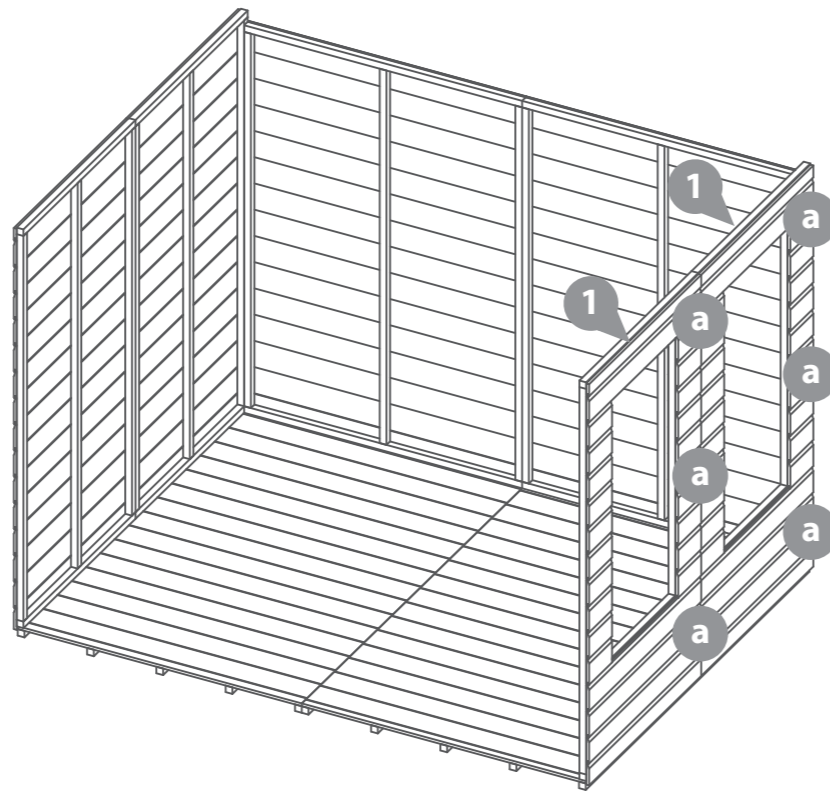

## 2ft EXTENSION PACK

10x8 SUMMER HOUSE ONLY

### Step 4a

Parts Needed- No.31 QTY 2

Place the Plain panels Extensions (No.31) onto the floor. Fix in an alternating pattern using 3x50mm screws per panel.

**Do not secure the building to the floor until the roof has been fitted.**

Position the panels so there is equal spacing between the floor and cladding on all sides.

6x50mm Screws

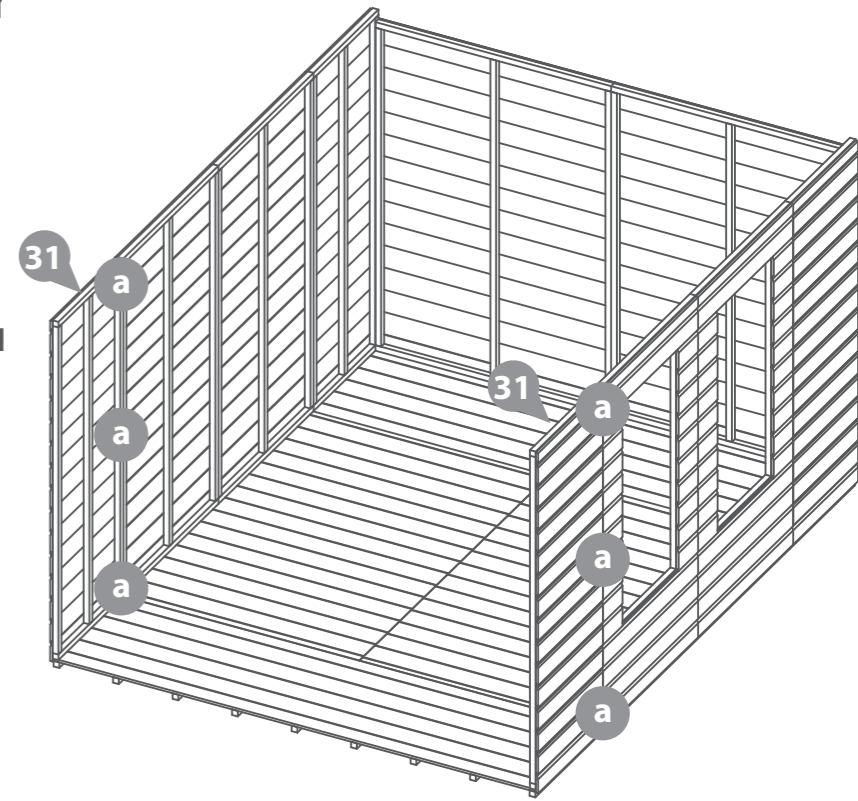
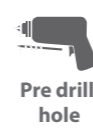

**Please note: The side panels are all interchangeable and can be positioned in a variety of configurations. Decide which works best before assembly**

## 2ft EXTENSION PACK

8x8 Summer House

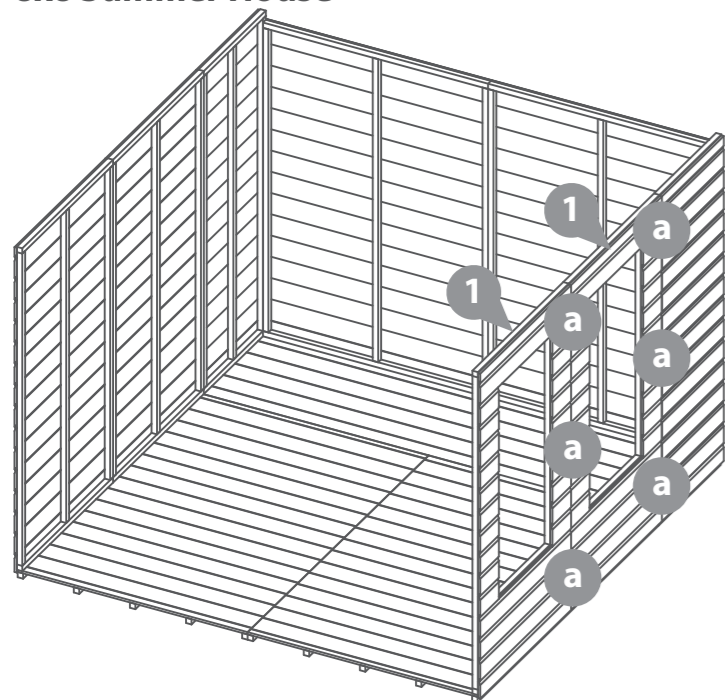

10x8 Summer House

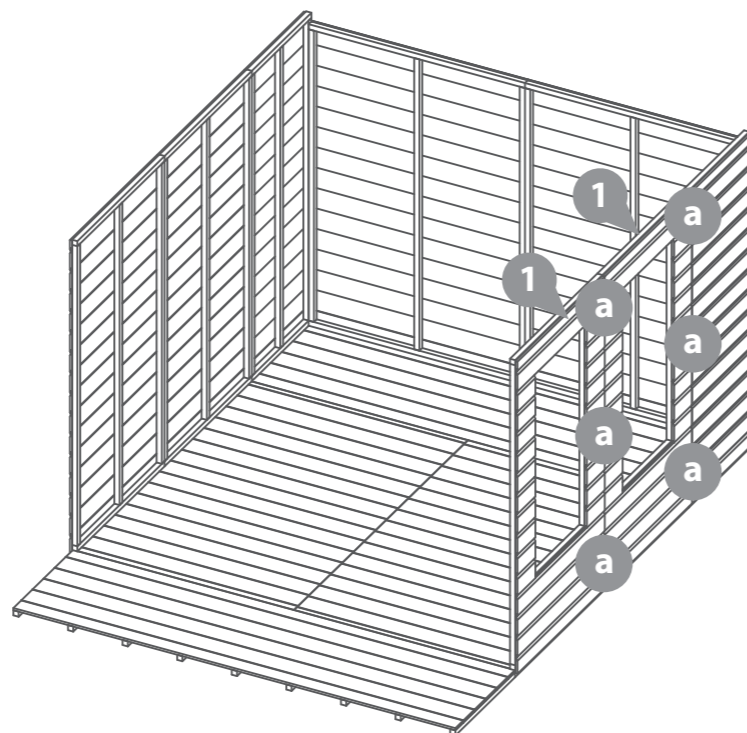

## Step 5

Parts Needed- No.7 QTY 2

Place the Front Window panel (No.7) onto the floor, fix the corners using 3x50mm screws

**Do not secure the building to the floor until the roof has been fitted.**

Position the panels so there is equal spacing between the floor and cladding on all sides.

The Front panels should sit lower than the Side panels

6x50mm Screws



Pre drill hole

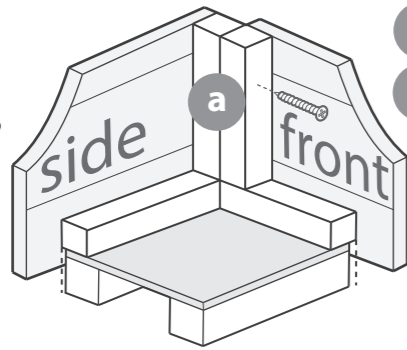

**IMPORTANT: Pre-drill before fixing screws.**

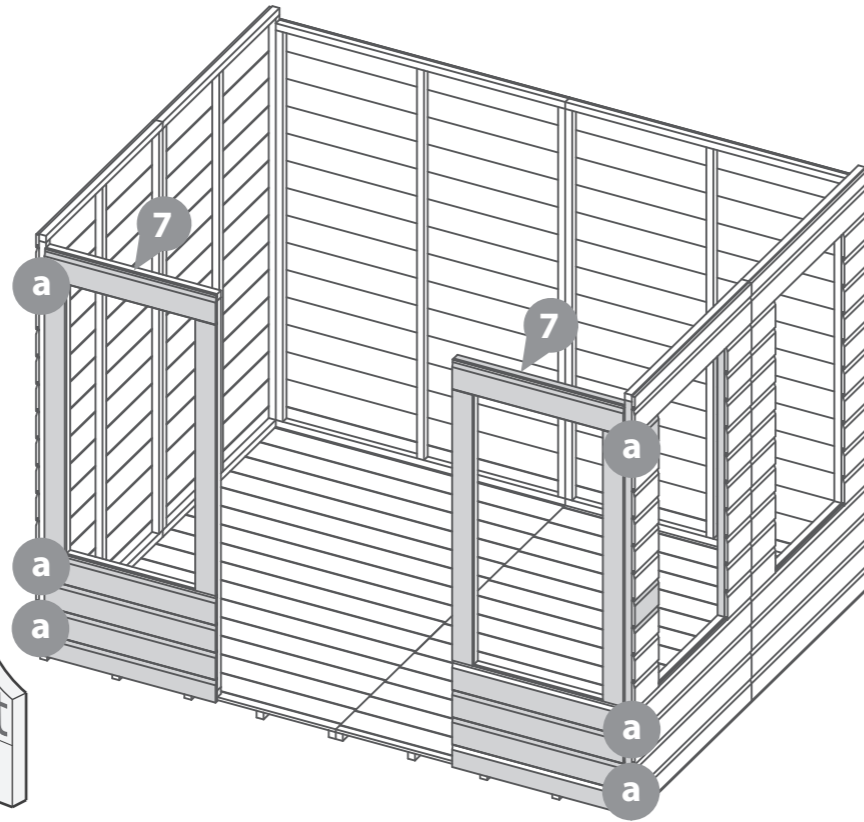

## Step 6

Parts Needed- No.12 QTY 1

Place the Door Framing (No.12) onto the floor, between the Front Window Panels. Ensure the framing is flush to the Window Panel framing.

**Ensure that the panels are all equally spaced to the floor before fixing the door framing.**

Secure the Door framing to the floor using 3x40mm screws

3x40mm Screws



Pre drill hole

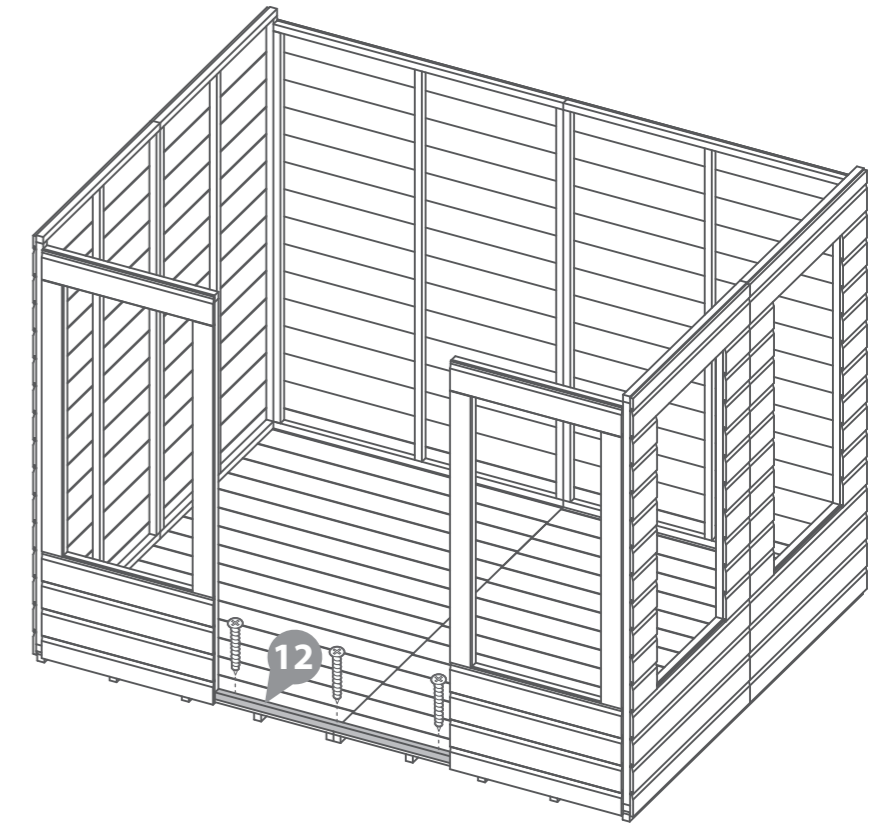

## 2ft EXTENSION PACK

8x8 Summer House

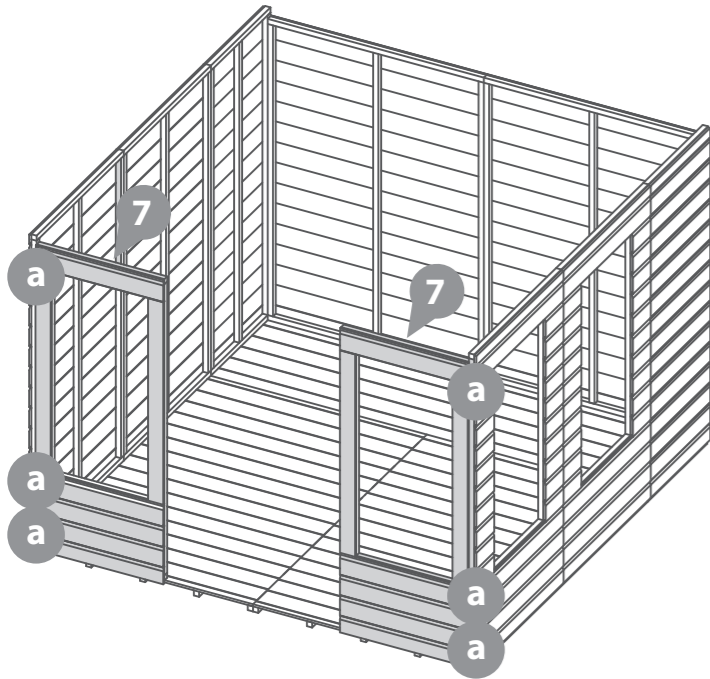

10x8 Summer House

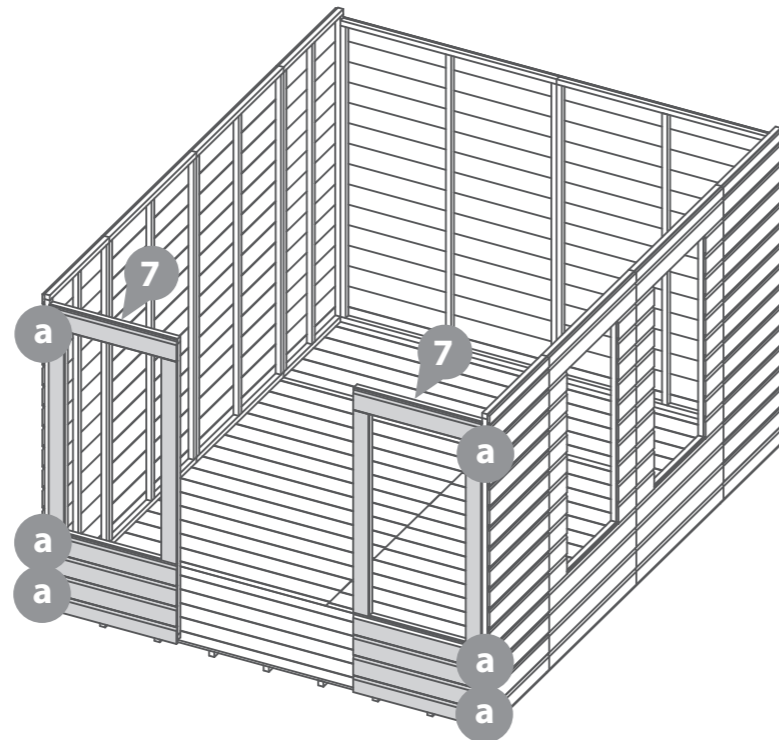

## Step 7

Parts Needed- No.10 QTY 1  
- No.11 QTY 1

Place the Plain Gable Top (No.10) on top of the Back panels. Fix using 6x50mm screws in an alternating pattern, going through the gable framing and into the panel framing below.

Place the Door gable top (No.11) on top of the Front Window Panel. Fix using 4x50mm screws

**Ensure Cladding is fitted correctly and flush to the panels before securing.**

10x50mm Screws



Pre drill hole

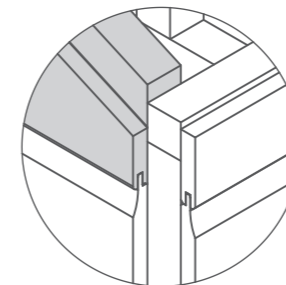

**IMPORTANT: Pre-drill before fixing screws.**

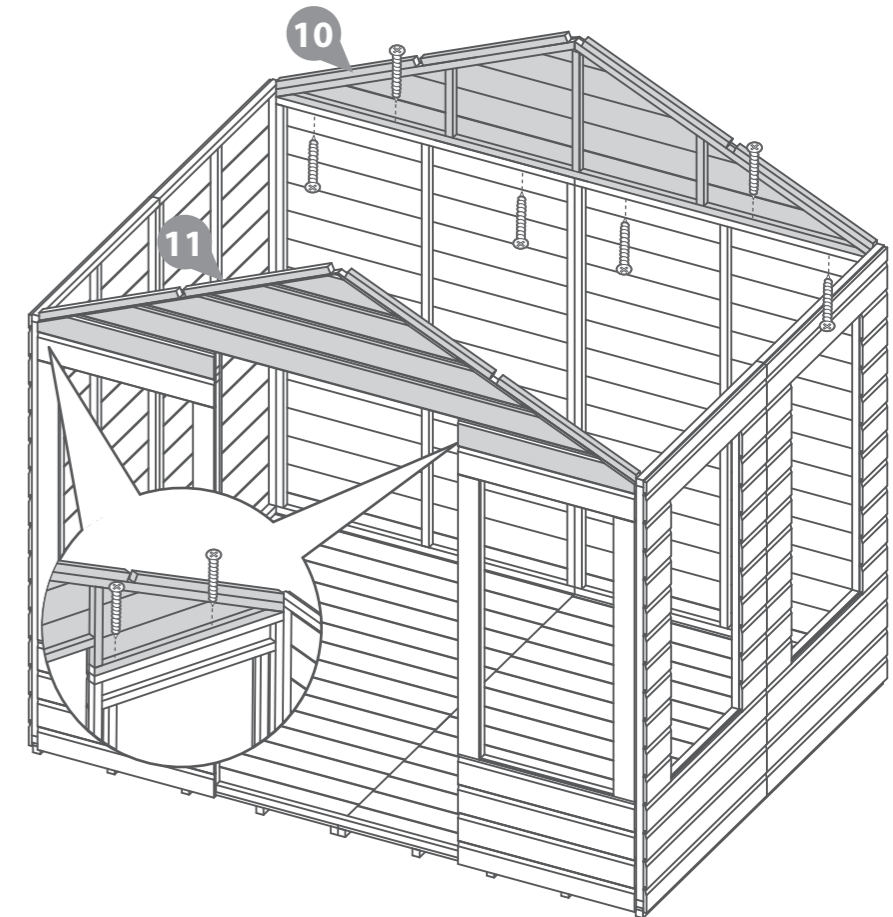



## Step 8

Parts Needed- No.19 QTY 1  
- No.24 QTY 2

Fix the Corner Braces (No.24) to each end of the Ridge Bar (No.19) using 2x30mm screws per corner brace.

Fix the Ridge bar to the top of each Gable using 2x30mm screws per corner brace. Ensure it is flush to the gable framing as shown.

8x30mm Screws

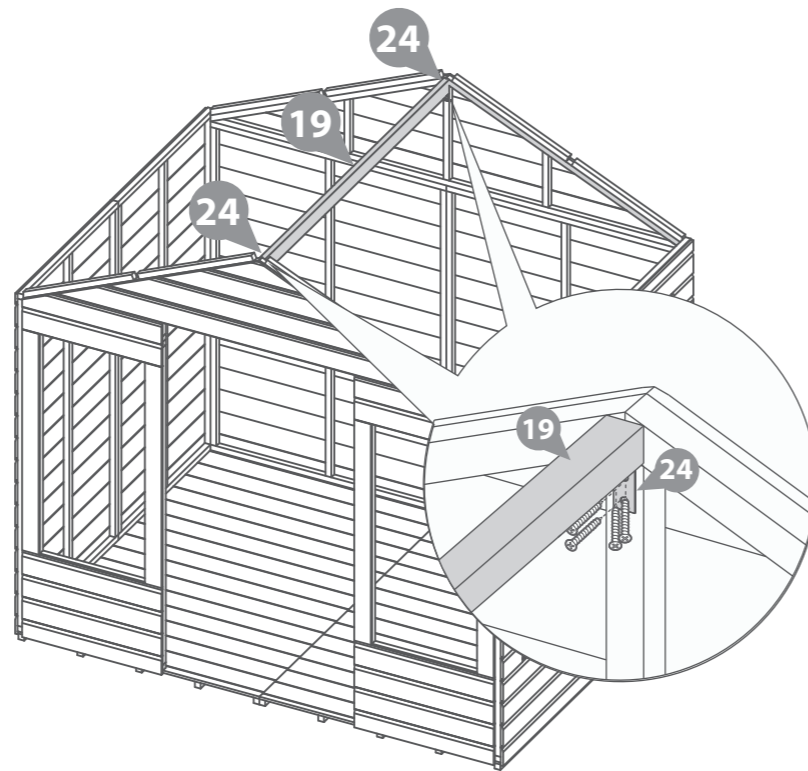
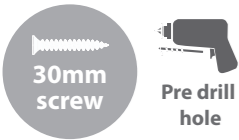

## 2ft EXTENSION PACK

### Step 8a

8x8 Summer House Parts Needed  
- No.33 QTY 1  
- No.34 QTY 1  
10x8 Summer House Parts Needed  
- No.33 QTY 2  
- No.34 QTY 2

Fix the Ridge bar Extension (No.33) to the Ridge Bar (No.19) using U Channels (No.34), secure the U Channels using 6x30mm screws per U channel

Fix the Corner Braces to each end of the assembled Ridge Bar using 2x30mm screws per corner brace.

Fix the Ridge bar to the top of each Gable using 2x30mm screws per corner brace. Ensure it is flush to the gable framing as shown.

14x30mm Screws (8x8 Summer House)  
20x30mm Screws (10x8 Summer House)

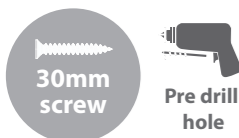

8x8 Summer House

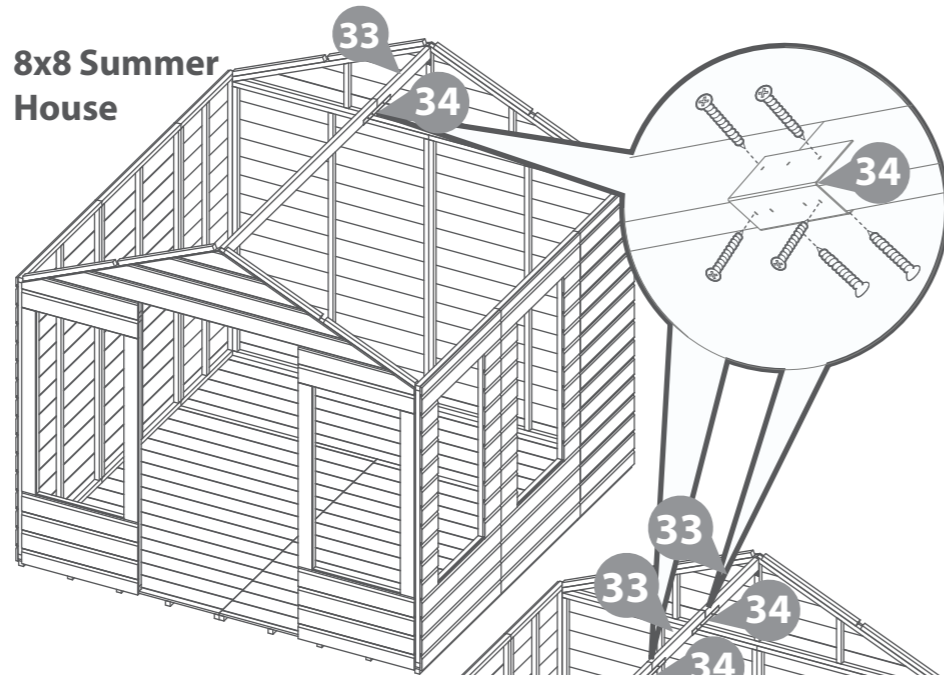

10x8 Summer House

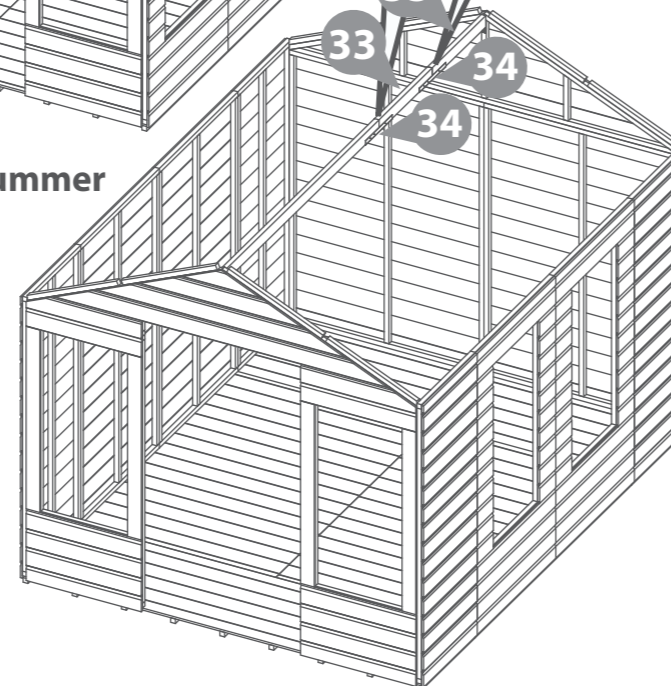

## Step 9

Parts needed - No. 5 QTY 2

For 2ft Extension Pack, go to Step 9a on the next page

Place the Roof Panels (No. 5) on top of the building making sure the framing in the roof panels sits firmly within the Gable Tops (No.10 and No.11) and on top of the Ridge Bar (No.19).

**\*\*Make sure that you have got the roof panels the correct way round with the recess at the top of the apex as shown in the diagram.\*\***

**\*\*The edges of the roof panels must be flush with the outer cladding of the Plain Gable Top (No.10).\*\***

From the top, fix directly through the roof panels (No.5) and into the ridge bar (No.19) the below using 5x60mm screws per roof panel.

It is essential that the ridge bar (No.19) and roof panel (No.5) framing pull together when fixed with 60mm screws. You may require another person pushing the ridge bar (No.19) up from below to achieve this.

HINT - Follow the nailing line of the framing on the roof panel so that you are more likely to fix into the ridge bar below.

Fix the remaining sides of the roof panels using 40mm screws, ensuring to go through to the framing below.

16x40mm Screws  
10x60mm Screws



IMPORTANT: Pre-drill before fixing screws.

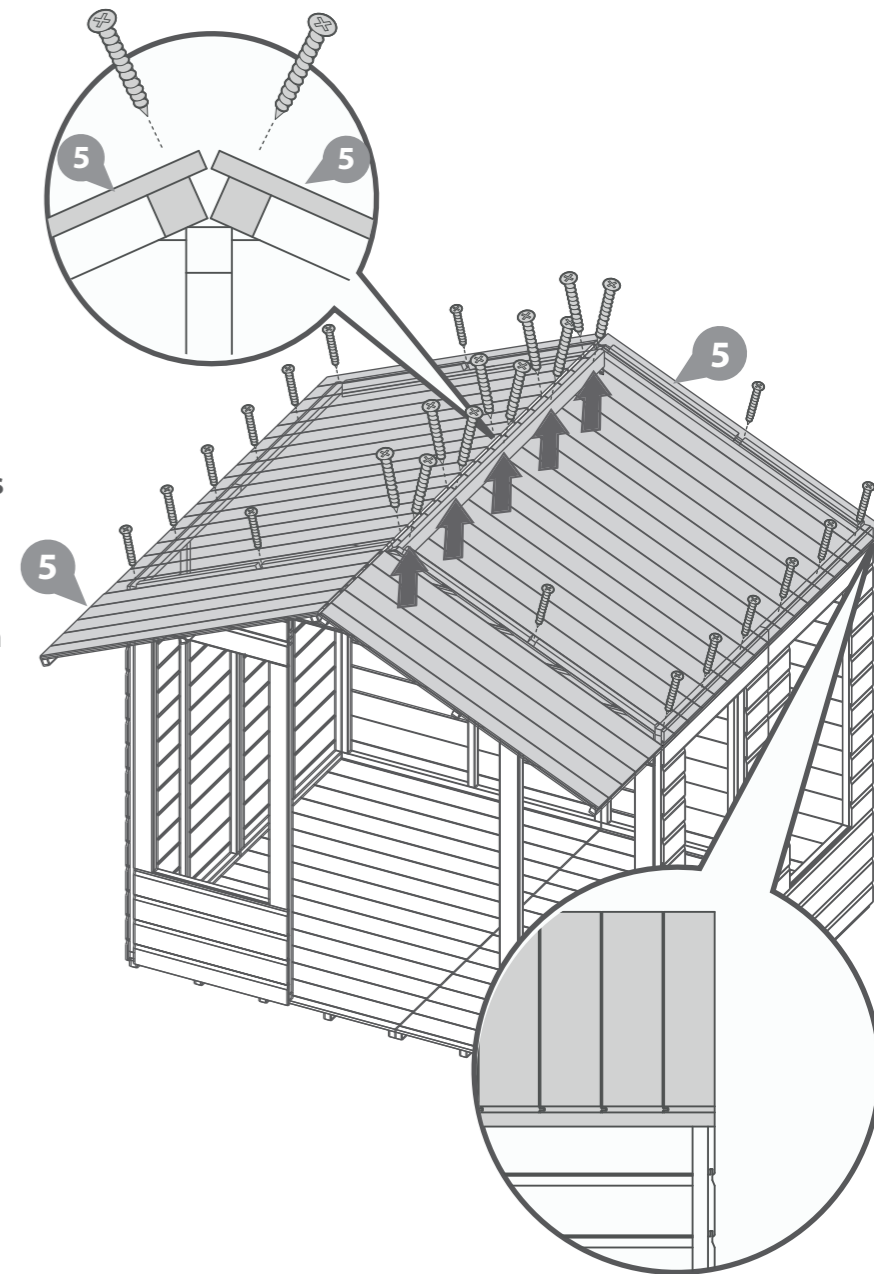

# 2ft EXTENSION PACK

## Step 9a

### 8x8 Summer House Parts Needed

- No.5 QTY 2
- No.30 QTY 2

### 10x8 Summer House Parts Needed

- No.5 QTY 2
- No.30 QTY 4

**a** Place a Roof Panel (No.5) and Roof extension panel (No.30) on to one side of the building making sure the framing in the roof panel sit firmly within the Gable Top (No.11) and on top of the Ridge Bar (No.19).

From the top, fix directly through the roof panels (No.5 and No.30) and into the ridge bar (No.19) below using 5x60mm screws per roof panel.

**\*\*Place Roof Extension panels (No.30) to the back of the building and keep the Roof Panel (No.5) to the front of the building\*\***

**\*\*Make sure that you have got the roof panels the correct way round with the recess at the top of the apex as shown in the diagram.\*\***

**\*\*The edges of the roof panels must be flush with the outer cladding of the Plain Gable Top (No.10).\*\***

**b** Once one side of the roof has been fixed to the ridge bar, lay the next Roof Panel (No.5) on top fo the building, using the fixed roofs as a guide and secure to the ridge bar using 5x60mm screws

**c** Following the lay out of the Roof extensions already laid on the bulindg, fix the remaining roof extensions onto the building and secure to the ridge bar using 2x60mm screws per Roof Extension

It is essential that the ridge bar (No.19) and roof panels framing pull together when fixed with 60mm screws. You may require another person pushing the ridge bar (No.19) up from below to achieve this.

HINT - Follow the nailing line of the framing on the roof panel so that you are more likely to fix into the ridge bar below.

Fix the remaining sides of the roof panels using 40mm screws, ensuring to go through to the framing below.

- (8x8 Summer House)**  
 20x40mm Screws  
 14x60mm Screws

- (10x8 Summer House)**  
 24x40mm Screws  
 18x60mm Screws

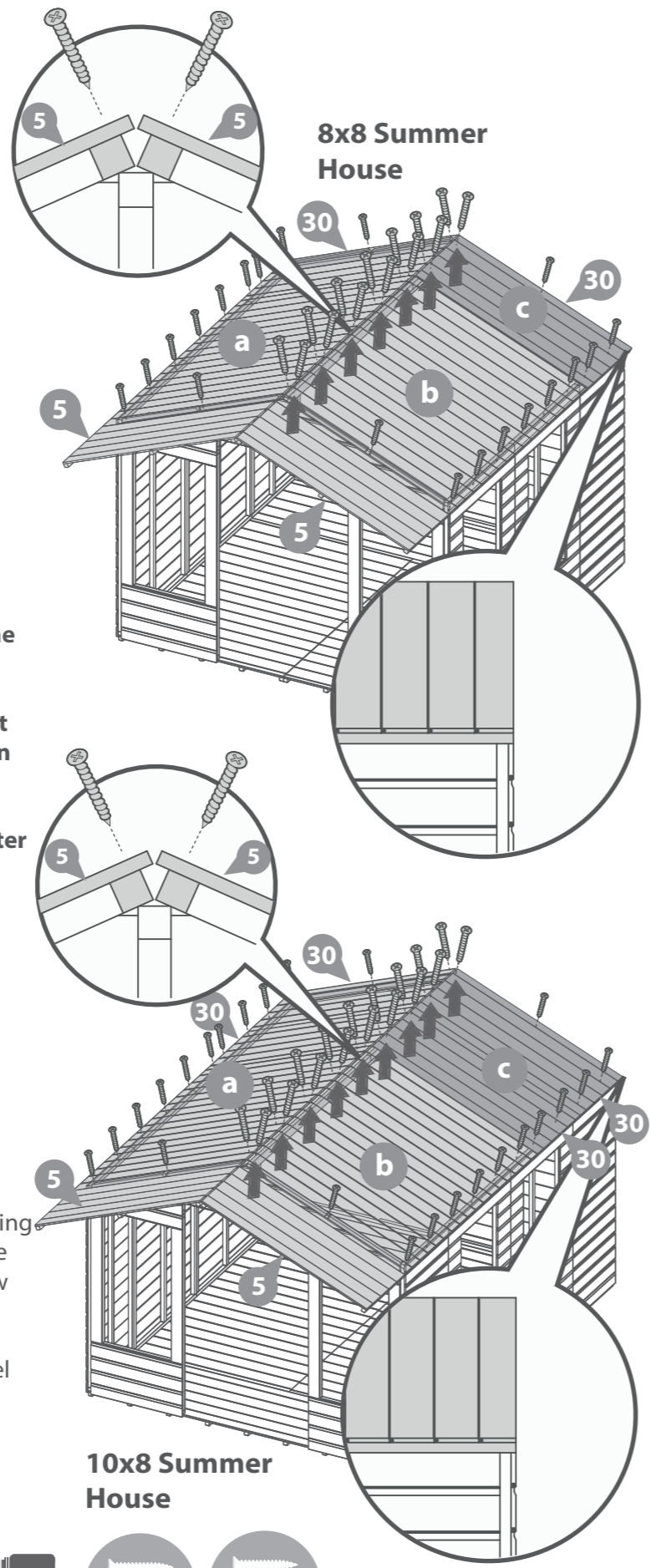

# 2ft EXTENSION PACK

## Step 9a Continued

### 8x8 Summer House Parts Needed

- No.34 QTY 2

### 10x8 Summer House Parts Needed

- No.34 QTY 4

Once the Roofs have been layed out, fix the U channel (No.34) to the Roof Panel (No.5) and the Roof Panel Extension (No.30).

Ensure the U channel is equally spaced over both roofs framing, secure the U channel using 6x30mm screws per channel

Repeat for both roof panels

**8x8 Summer House-**  
 12x30mm Screws

**10x8 Summer House-**  
 24x30mm Screws

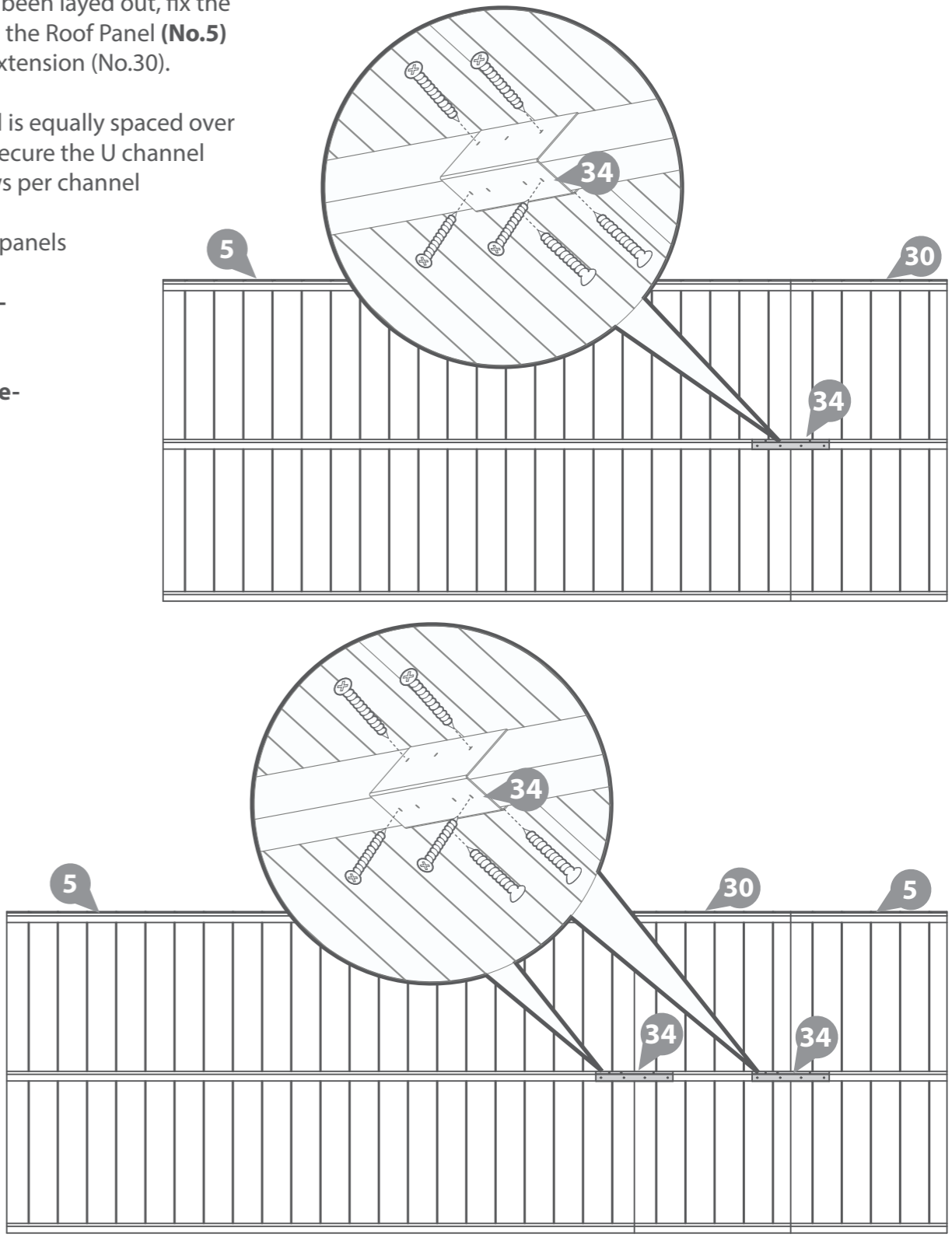

## Step 10

Once the roof is fixed, attach the building to the Floor with 50mm screws.

Ensure the screws go through the panel into the Floor framing

### 30x50mm Screws

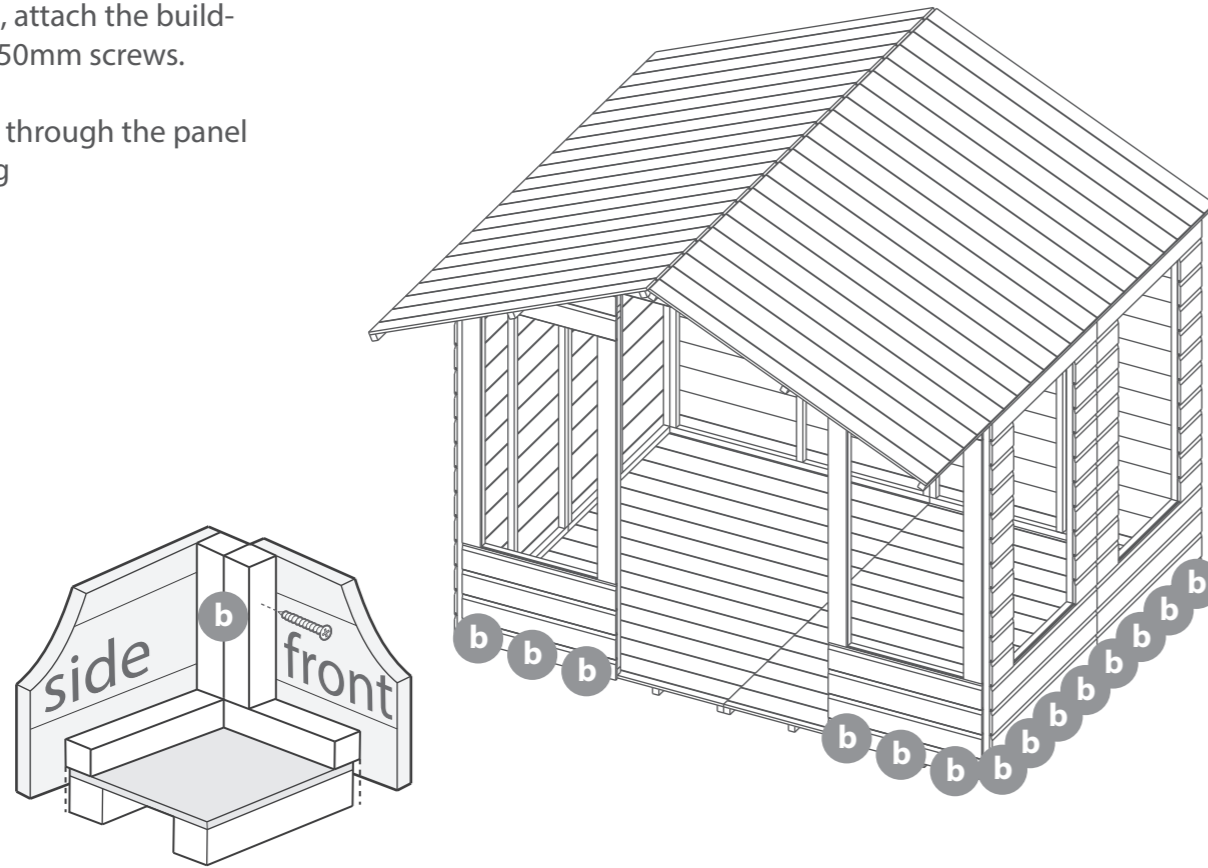
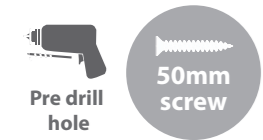

## Step 11

Parts Needed- No.4 QTY 4  
- No.25 QTY 16

Fix the Window Blocks (No. 25) to the sides, top and bottom (internally) of the Window (No.4) as shown with 1x30mm screw per block.

4 Window blocks should be used per window

Place the Window into the window hole in the Front and Side Window Panel and fix by screwing through the Window Block (No.25) into the framing using 2x30mm screws per block, as shown.

### 48x30mm screws.



**IMPORTANT: Pre-drill before fixing screws.**

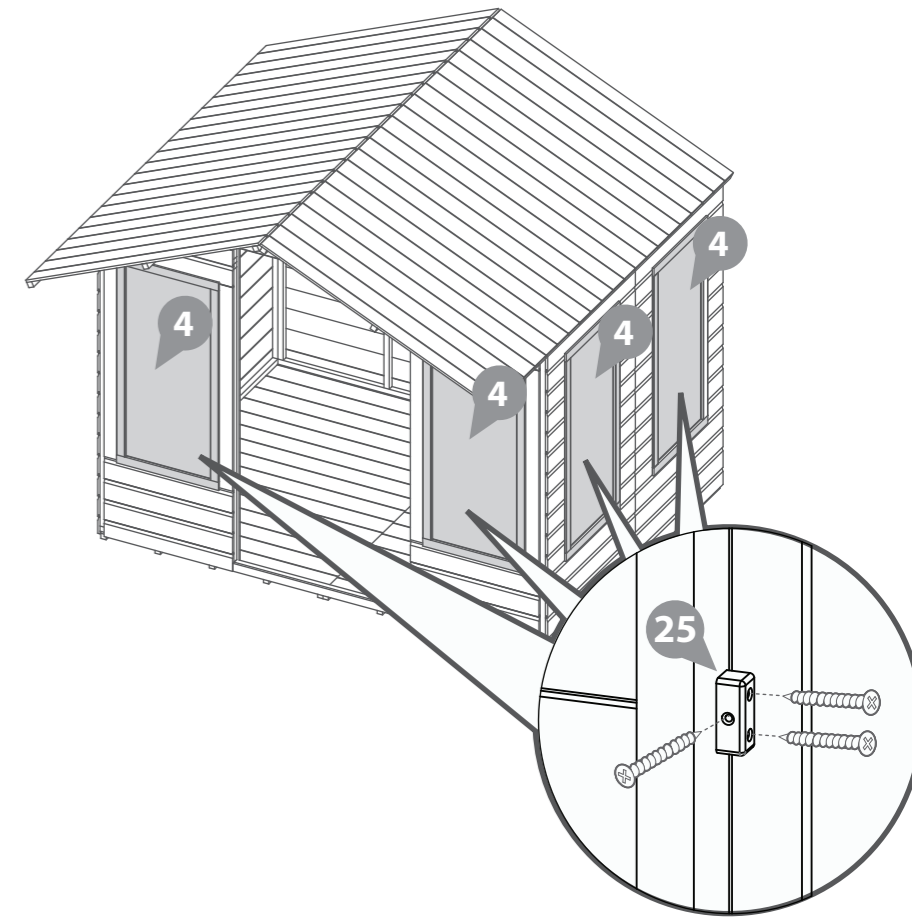

## 2ft EXTENSION PACK Step 10a

### 8x8 Summer House

34x50mm Screws

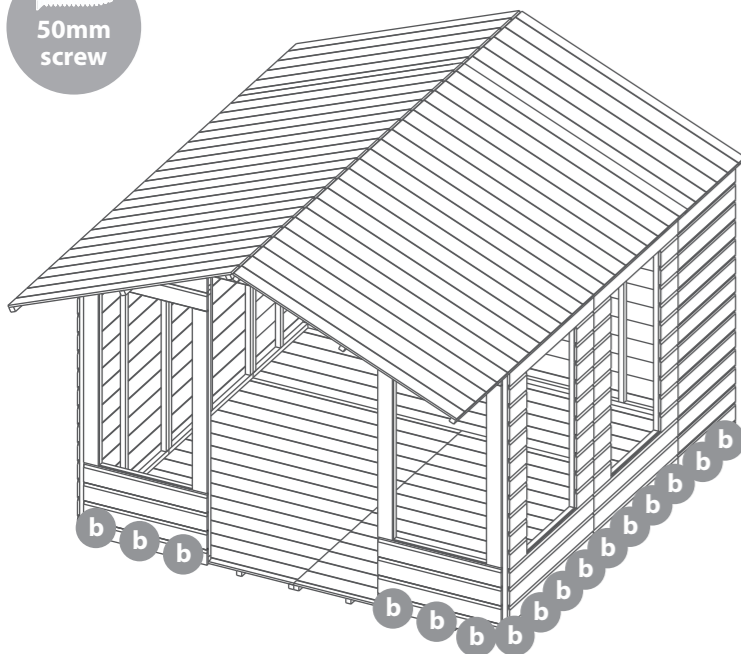

### 10x8 Summer House

38x50mm Screws

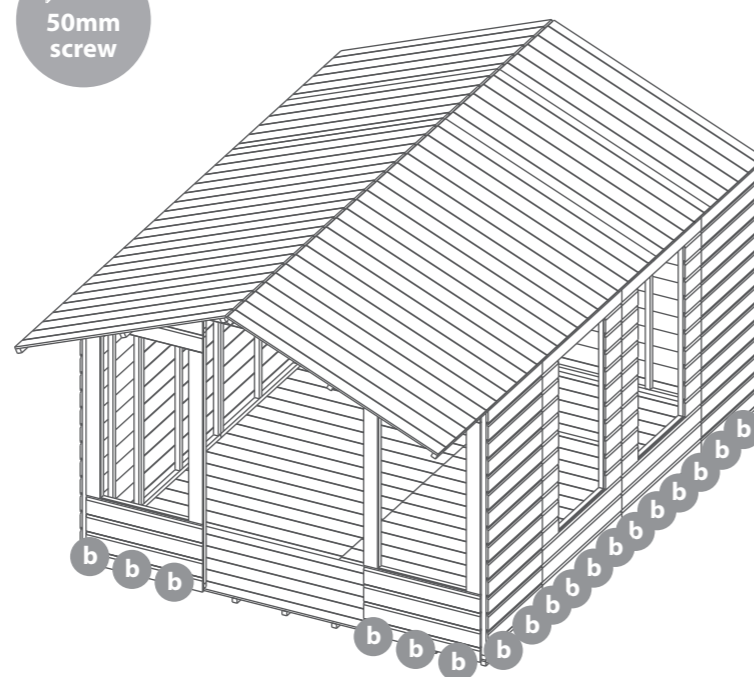

## Step 12

Parts Needed- No.8 QTY 1  
 - No.9 QTY 1  
 - No.22 QTY 6

Fix 3 Hinges (No. 22) to each Door (No.8 and No.9) securing with 4x30mm black screws per hinge. Position as shown.

Fix each Door to the building with 4x30mm black screws per hinge.

Ensure the doors open and close freely.

48x30mm Black screws.

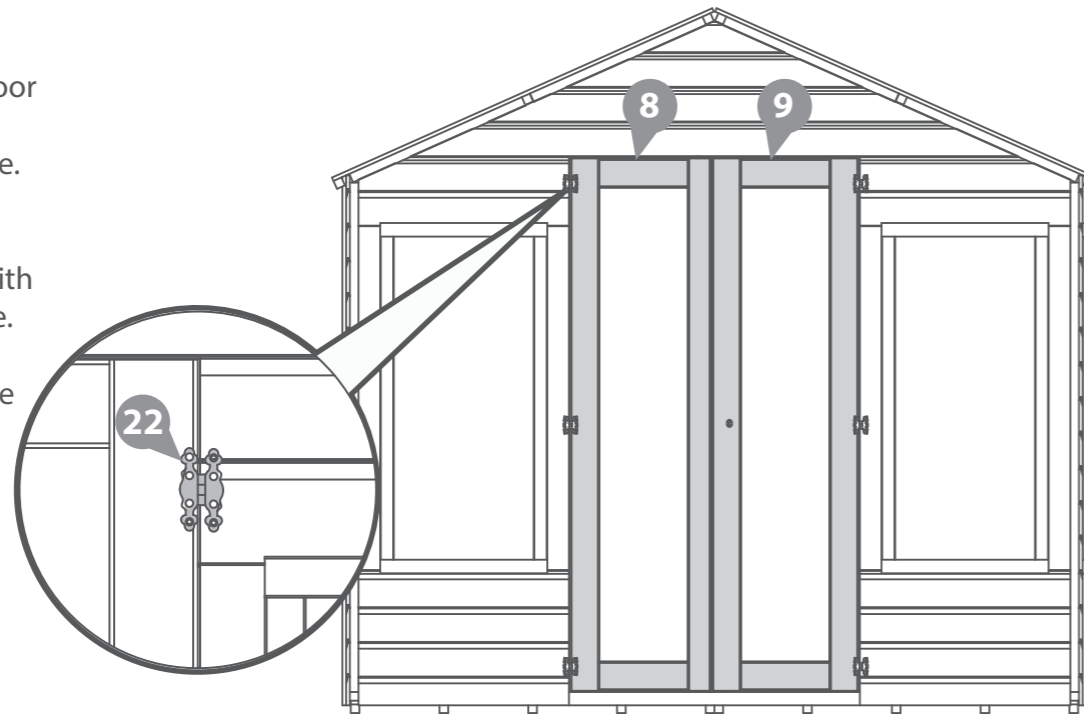
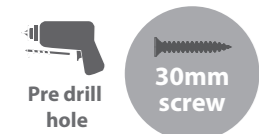

IMPORTANT: Pre-drill before fixing screws.

## Step 14

Parts Needed- No.15 QTY 1  
 - No.16 QTY 2

On the inside of the building fix the Door Frame Strips (No.15 and No.16), to the top and sides of the doors frames. Make sure that the edges are flush with the edge of the framing. Fix with 4x30mm screws per strip.

12x30mm Screws

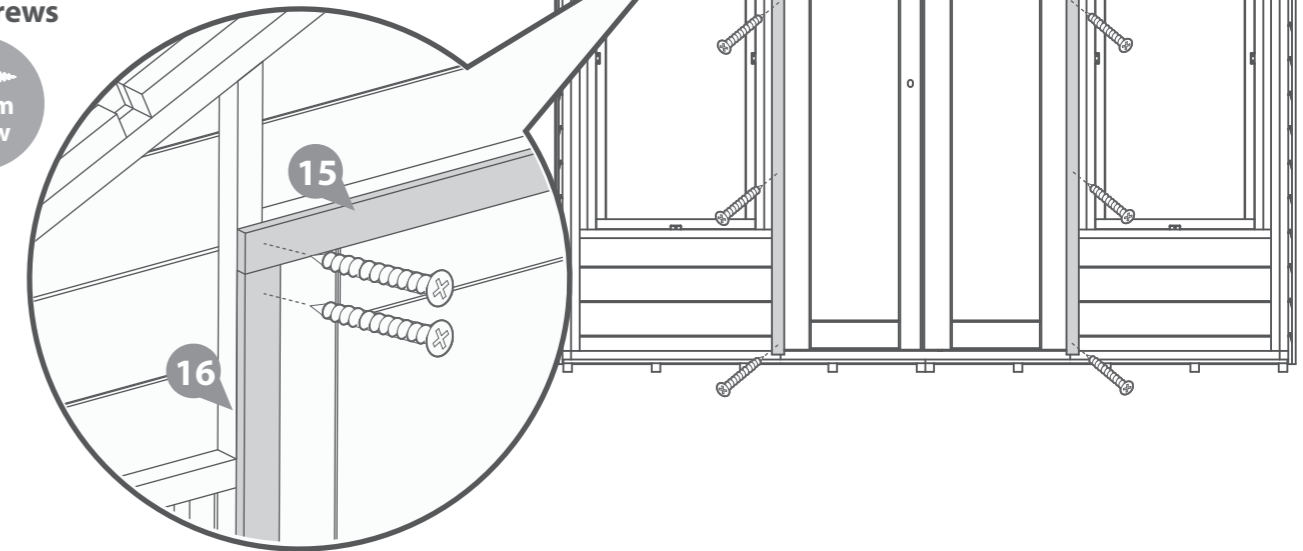

Internal View

## Step 13

Parts Needed- No.21 QTY 2  
 - No.17 QTY 1

Fix a Ring Pull (No. 21) to the front of each door using 4x20mm black screws per ring pull.

Fix the Door Cover trim (No.17) to the bottom of the door opening, secure to the framing piece using 3x30mm screws, ensuring the top of the cover trim is flush with the framing

8x20mm black screws.  
 3x30mm screws

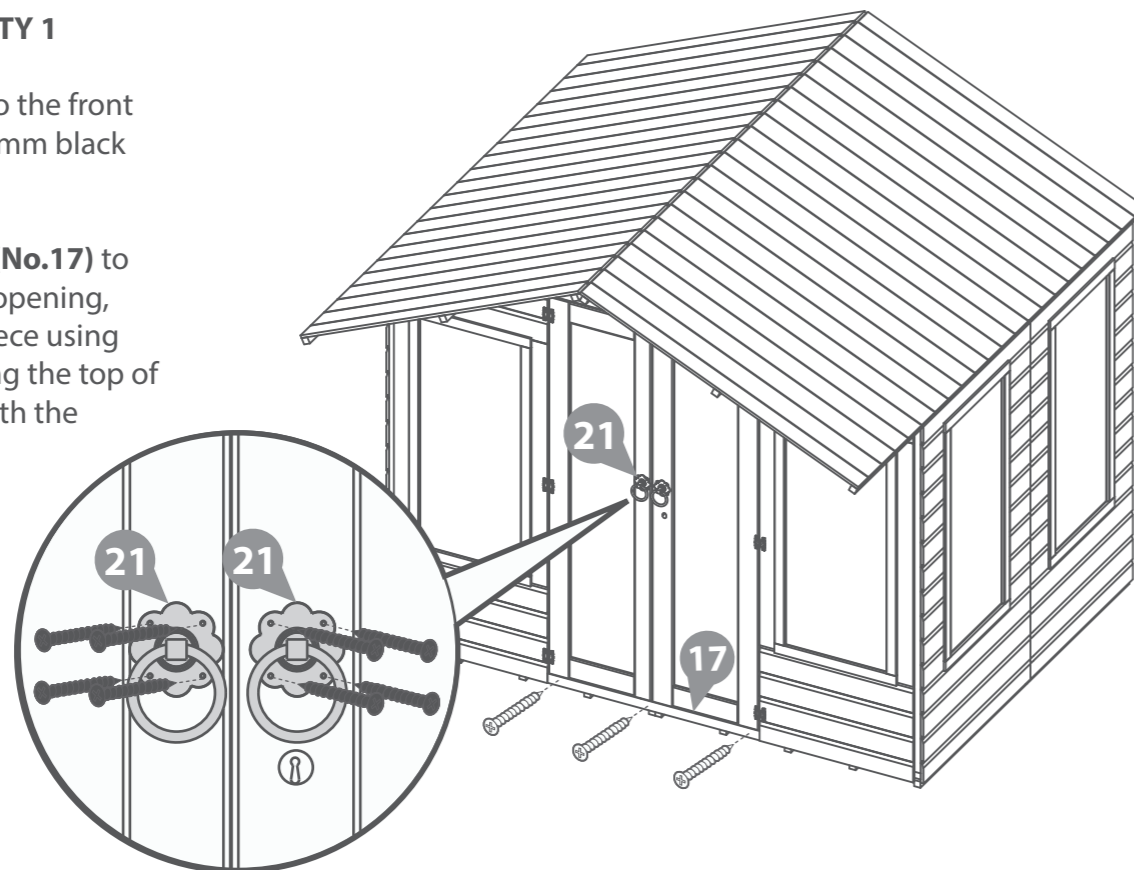
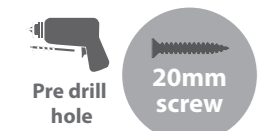

IMPORTANT: Pre-drill before fixing screws.

## Step 15

Parts Needed- No.20 QTY 1

Fix the Press lock (No.20) to the back (internally) of the Master door (No. 9) with 4x20mm black screws. Making sure to align the key holes.

4x20mm Black screws.

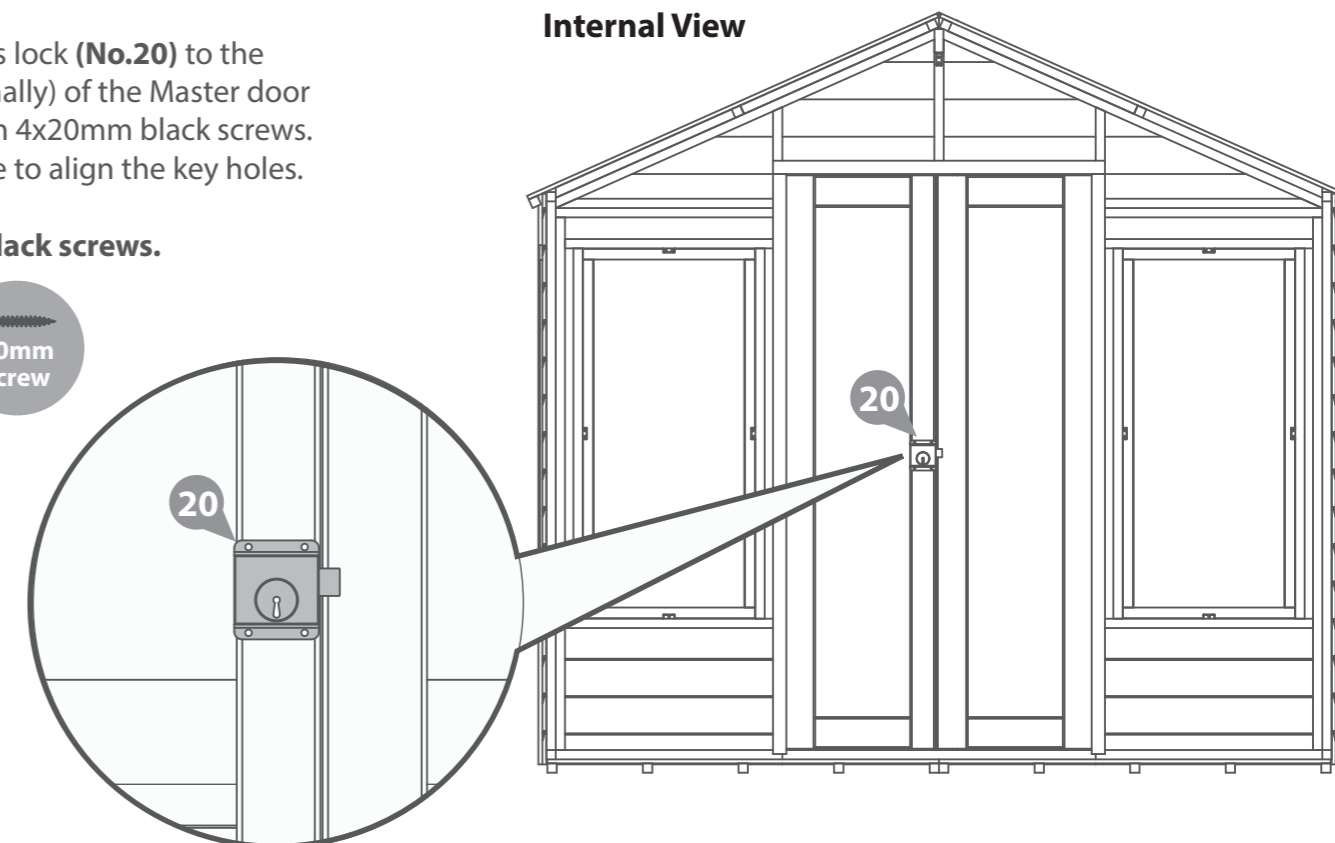

Internal View

IMPORTANT: Pre-drill before fixing screws.

## Step 16

Parts Needed- No.28 QTY 2

Attach the tower bolts (No.28) to the top and bottom of the secondary door using 4x20mm screws per bolt.

*\*Mark the position of the bolt with a pencil on the framing and drill a hole to site the bolts.*

8x20mm black screws

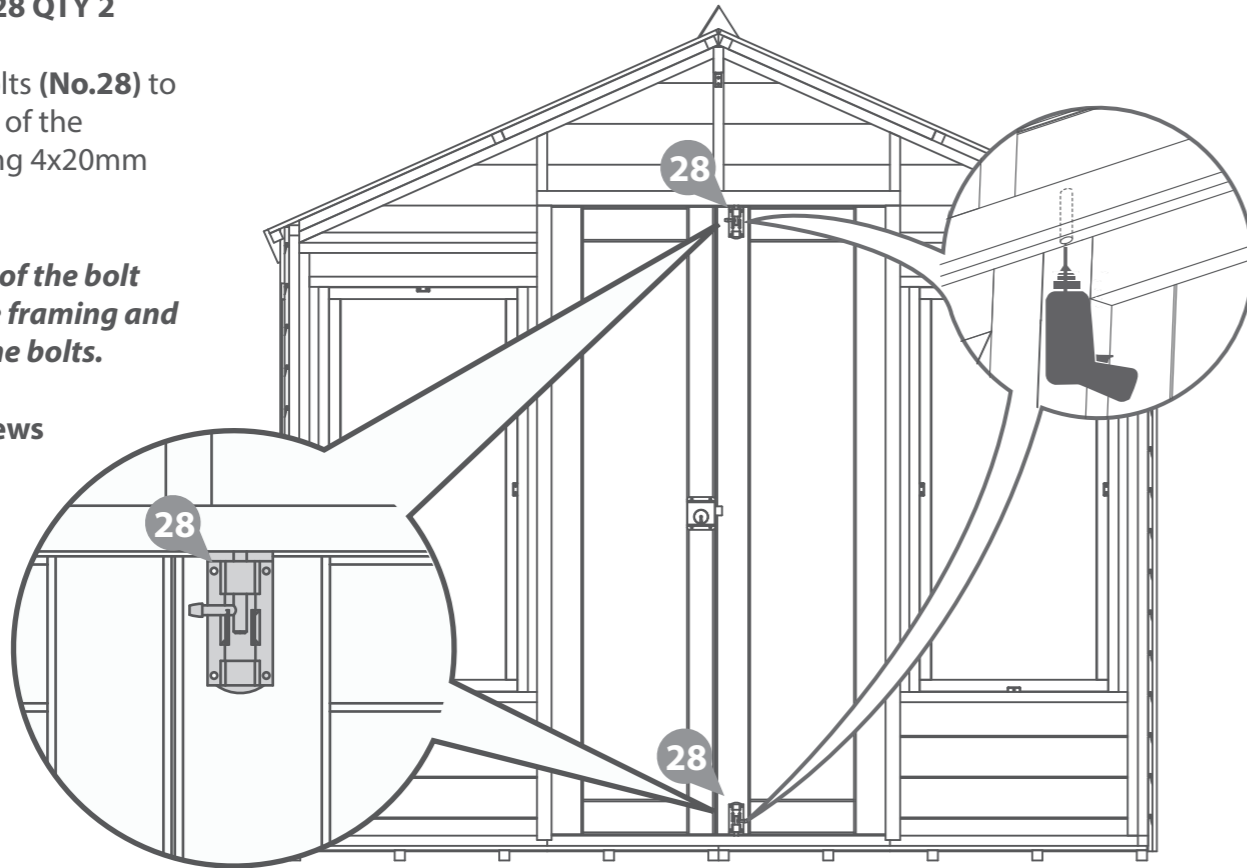

**IMPORTANT: Pre-drill before fixing screws.**

## Step 18

Parts Needed- No.14 QTY 7

Fix the Cover trims (No. 14) to each corner and over the panel joins, secure using 3x30mm screws per cover trim.

Cover trims may need cutting to size

21x30mm Screws.



Pre drill hole



30mm screw



\*Cut down trims to fit

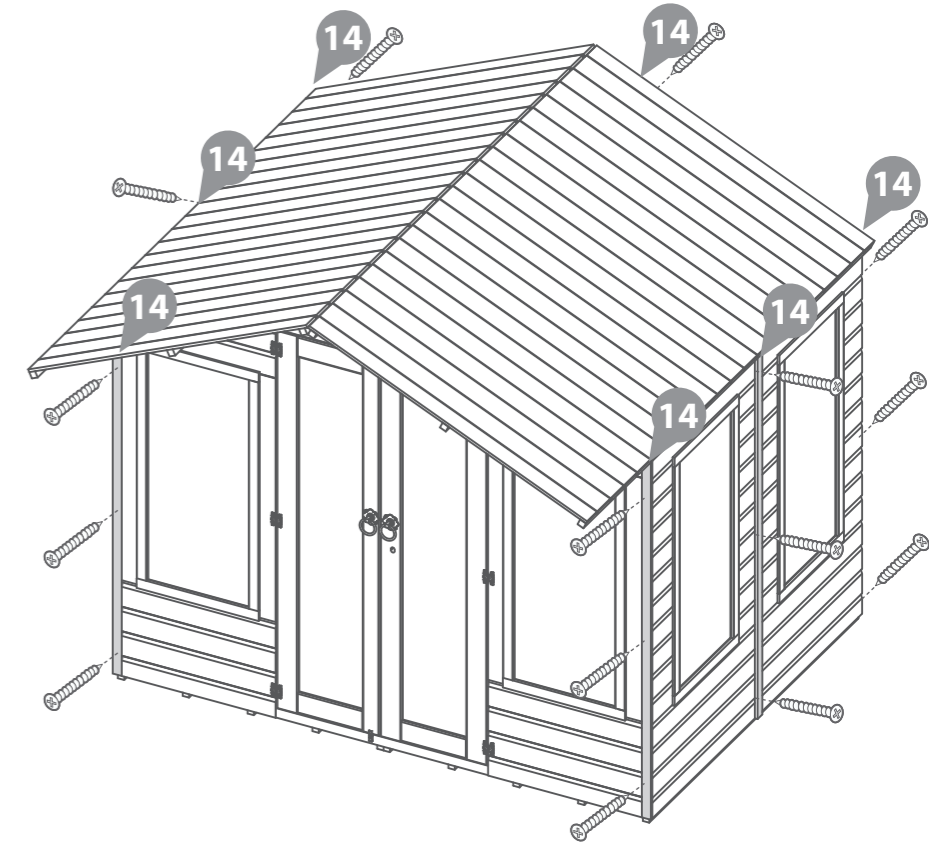

**IMPORTANT: Pre-drill before fixing screws.**

## Step 17

Parts Needed- No.23 QTY 2

Fix the Turn Buttons (No.23) above each door (externally) using 1x20mm black screw per Turn Button.

2x20mm Black screws.



Pre drill hole



20mm screw

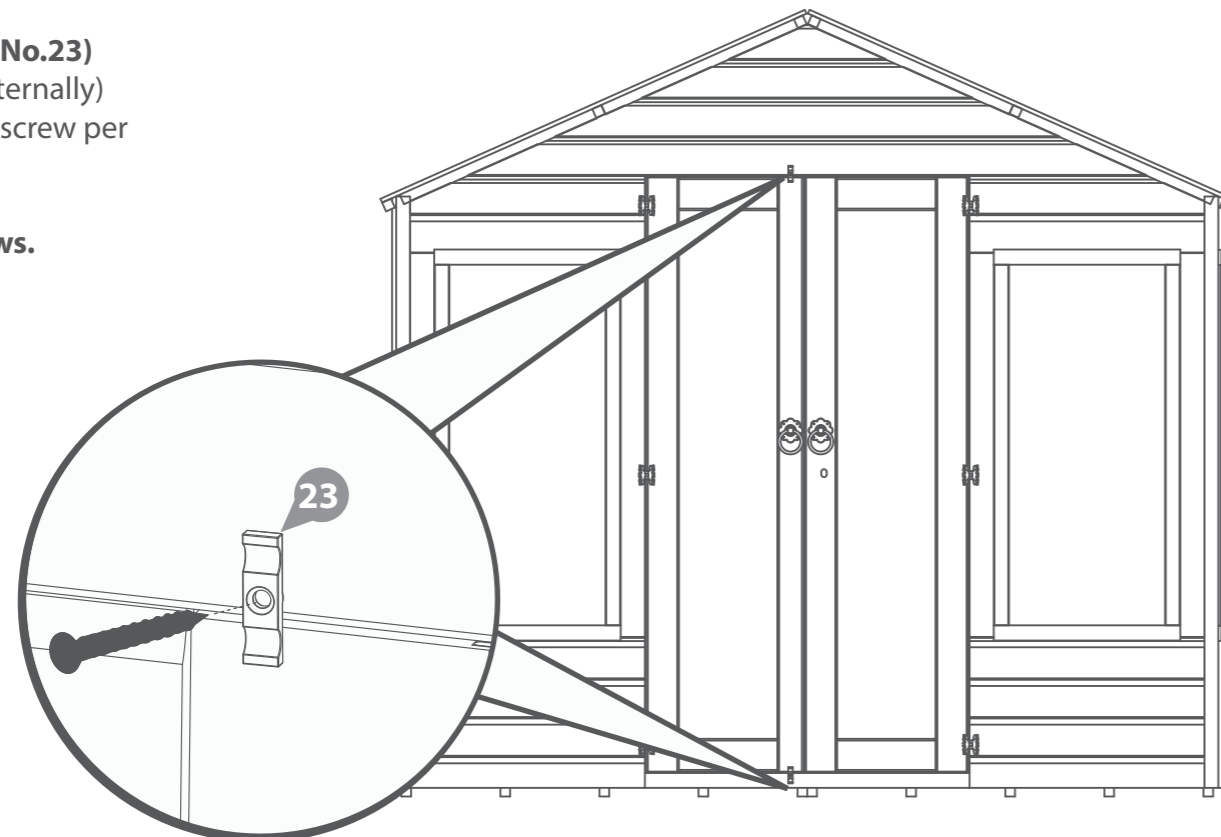

**IMPORTANT: Pre-drill before fixing screws.**

## 2ft EXTENSION PACK

### Step 18a

8x8 Summer House Parts Needed - No.14 QTY 9

10x8 Summer House Needed - No.14 QTY 11

27x30mm Screws (8x8 Summer House)

33x30mm Screws (10x8 Summer House)

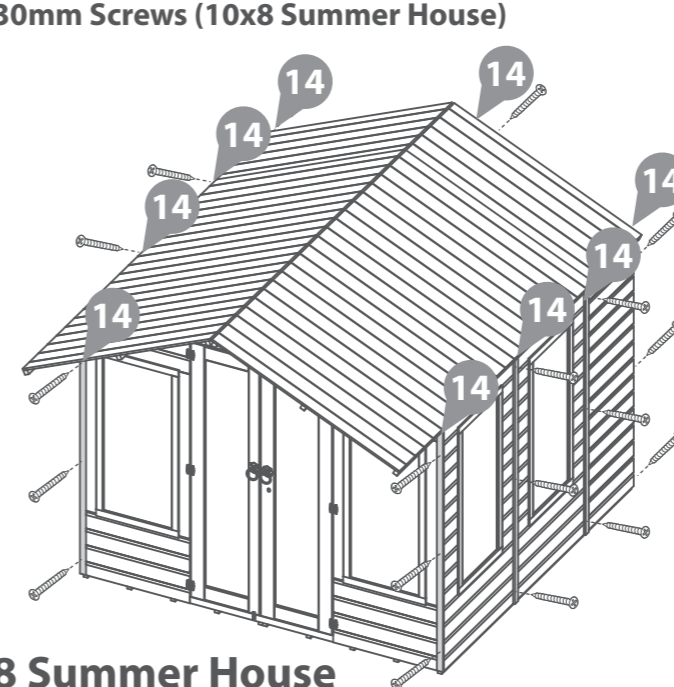

8x8 Summer House

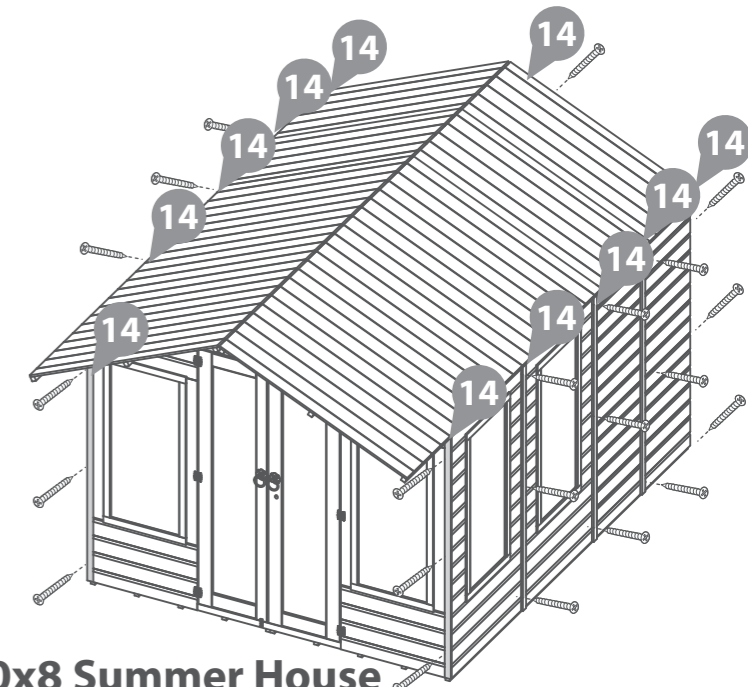

10x8 Summer House

## Step 19

Parts Needed- No.13 QTY 4

Fix the Gable Cover Trims (No.13) to the building with 2x30mm screws per Trim.

The Gable Cover Trims will need to be cut to fit the angle.

8x30mm screws.



**IMPORTANT: Pre-drill before fixing screws.**

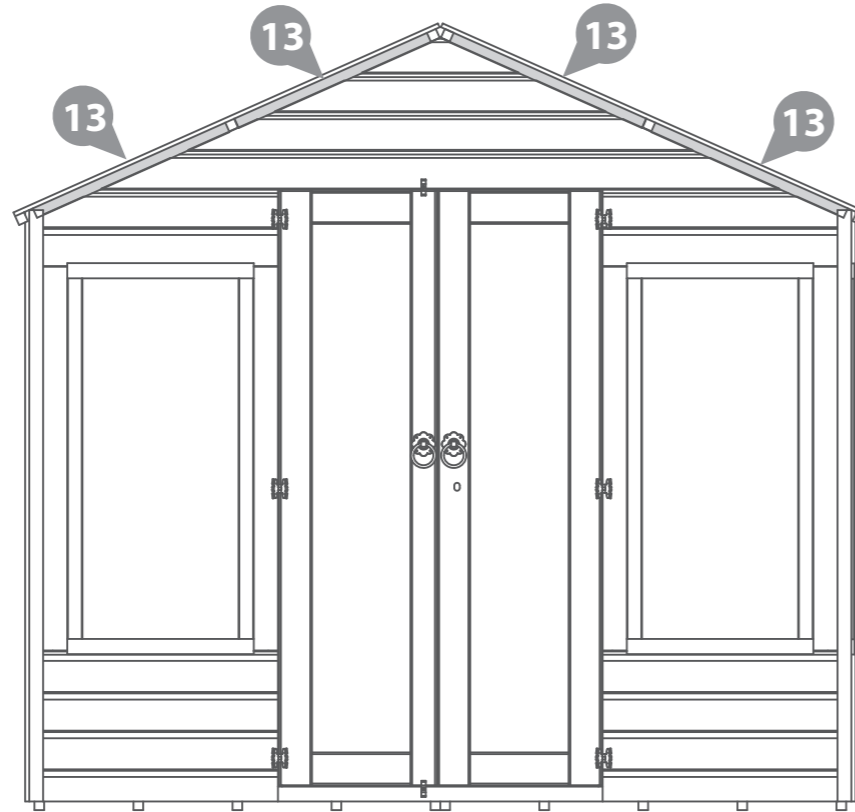

## Step 20

Parts Needed- No.27 QTY 1

Cut the Felt (No. 27) into 3 sheets of 2510mm and lay onto the roof in the order shown in the diagram. Making sure there is 50mm of overhang on each side.

Fix to the buildings using evenly spaced felt tacks.

150 x Felt tacks.

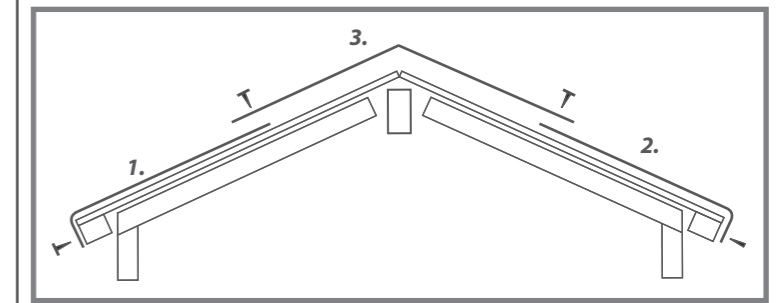
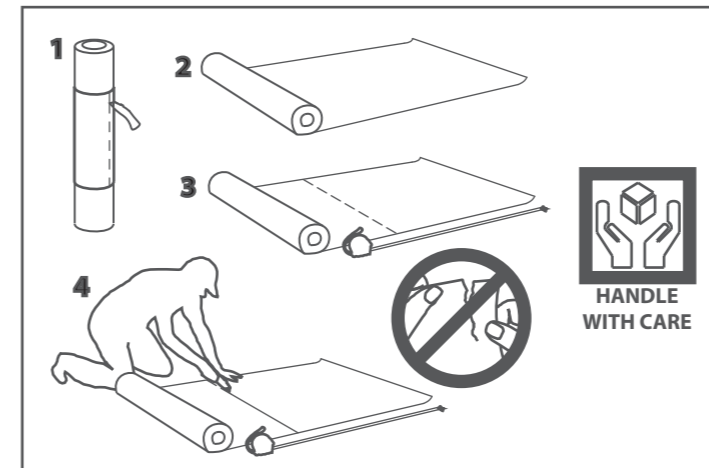
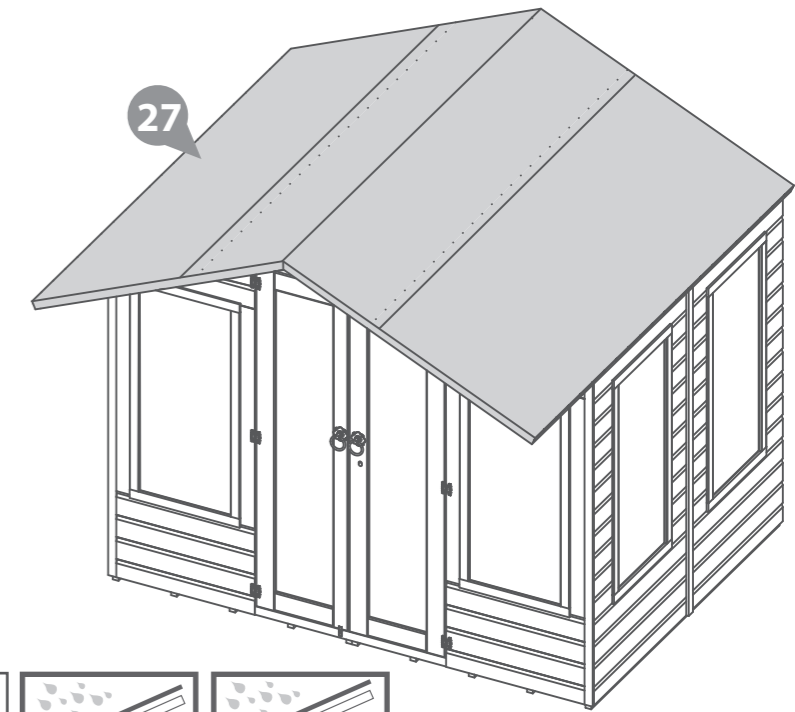

## 2ft EXTENSION PACK

### Step 20a

#### 8x8 Summer House

Felt Dimensions Required:  
3110mm (L) x 1000mm (W)

175 x Felt tacks.

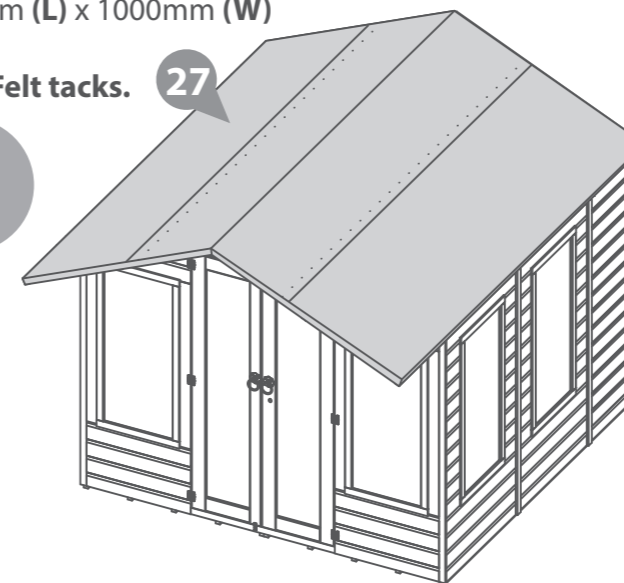

#### 10x8 Summer House

Felt Dimensions Required:  
3710mm (L) x 1000mm (W)

200 x Felt tacks.

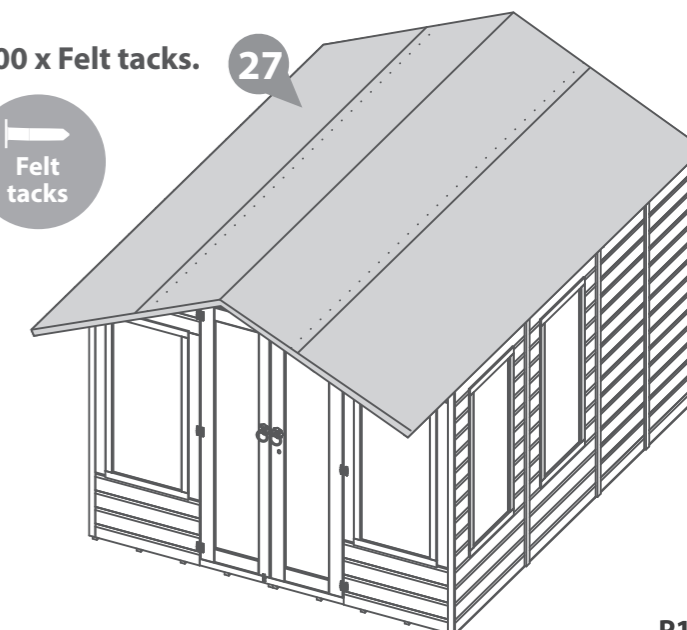

If Veranda Pack has been purchased, Please Go to **Page 15** and continue from **Step 20b**

## Step 21

Parts Needed- No.18 QTY 4  
- No.26 QTY 2

Fix the Fascia (No. 18) to each end of the roof, securing with 3x30mm screws per Fascia. Ensure the screws go through the roof framing

Fix the Diamond Finials (No.26) to the Fascias using 2x30mm screws per finial.

10x30mm Screws.

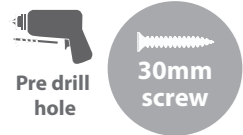

**IMPORTANT: Pre-drill before fixing screws.**

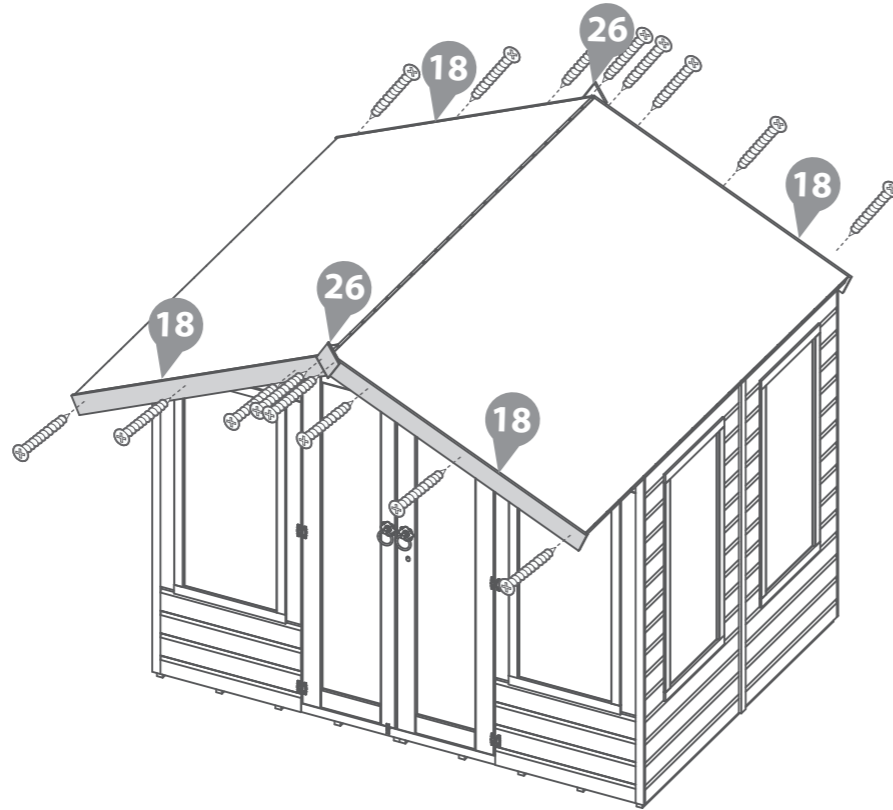

## VERANDA PACK

### Step 20b

Parts Needed- No.35 QTY 4

Place the Veranda (No.35) at the front of the building, flush to the front of the building. Secure using 4x50mm Screws at an angle into the front of the building.

4x50mm screws.

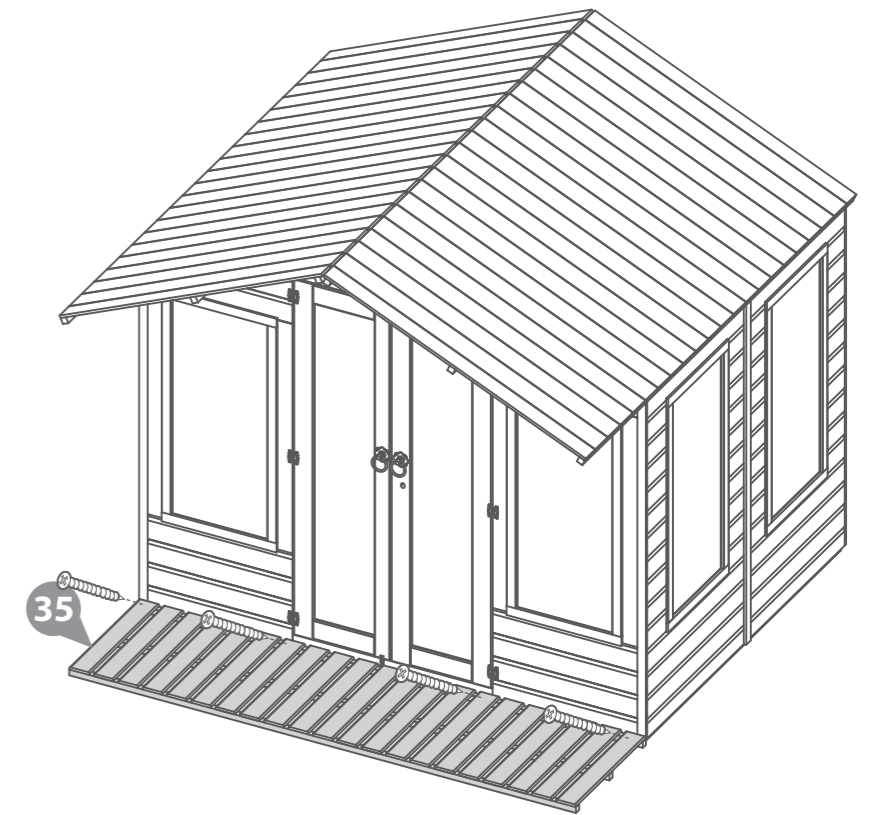

### Step 21b

Parts Needed- No.36 QTY 2

Fix the Rails (No.36) to the building using 2x40mm screws per railing, ensuring to go through to the Cover trim on the front of the building. Using 4x40mm screws, fix the rails to the veranda floor

8x40mm screws.

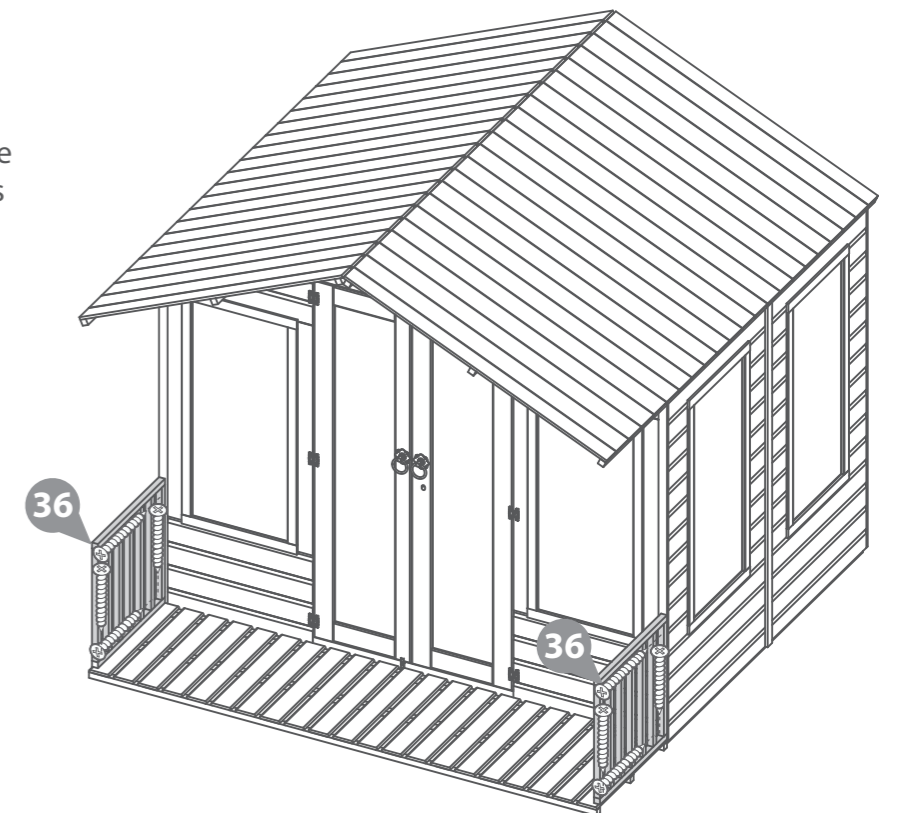
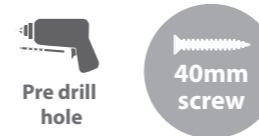

It is **ESSENTIAL** that you apply wood treatment immediately after the building has been assembled.

AFTER TREATMENT: score around protective cover on glazing and carefully peel covering back

## Step 22b

Parts Needed- No.37 QTY 2

Fix the Roof Support (No.37) to the building by screwing through the roof into the top of the framing using 1x50mm screw and through the framing into the railing using 2x50mm screws, as shown.

6x50mm screws.



50mm screw

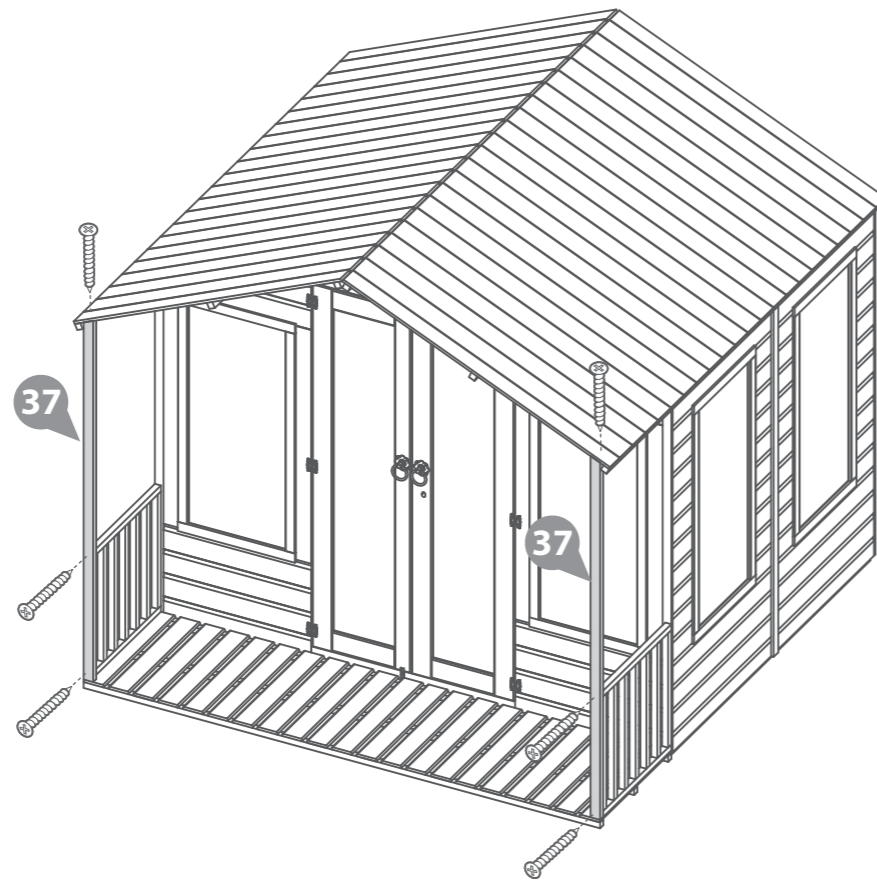

## Step 23b

Parts Needed- No.38 QTY 8  
- No.39 QTY 4

Locate the Window Crosses (No.38 and No.39) into the windows.

Fix by screwing through the Cross into the Window framing using 6x20mm screws, as shown in the diagram.

Further secure the crosses by screwing 1x10mm screw at each meeting point, as shown in the diagram.

24x20mm screws.  
8x10mm screws.



10mm screw

20mm screw

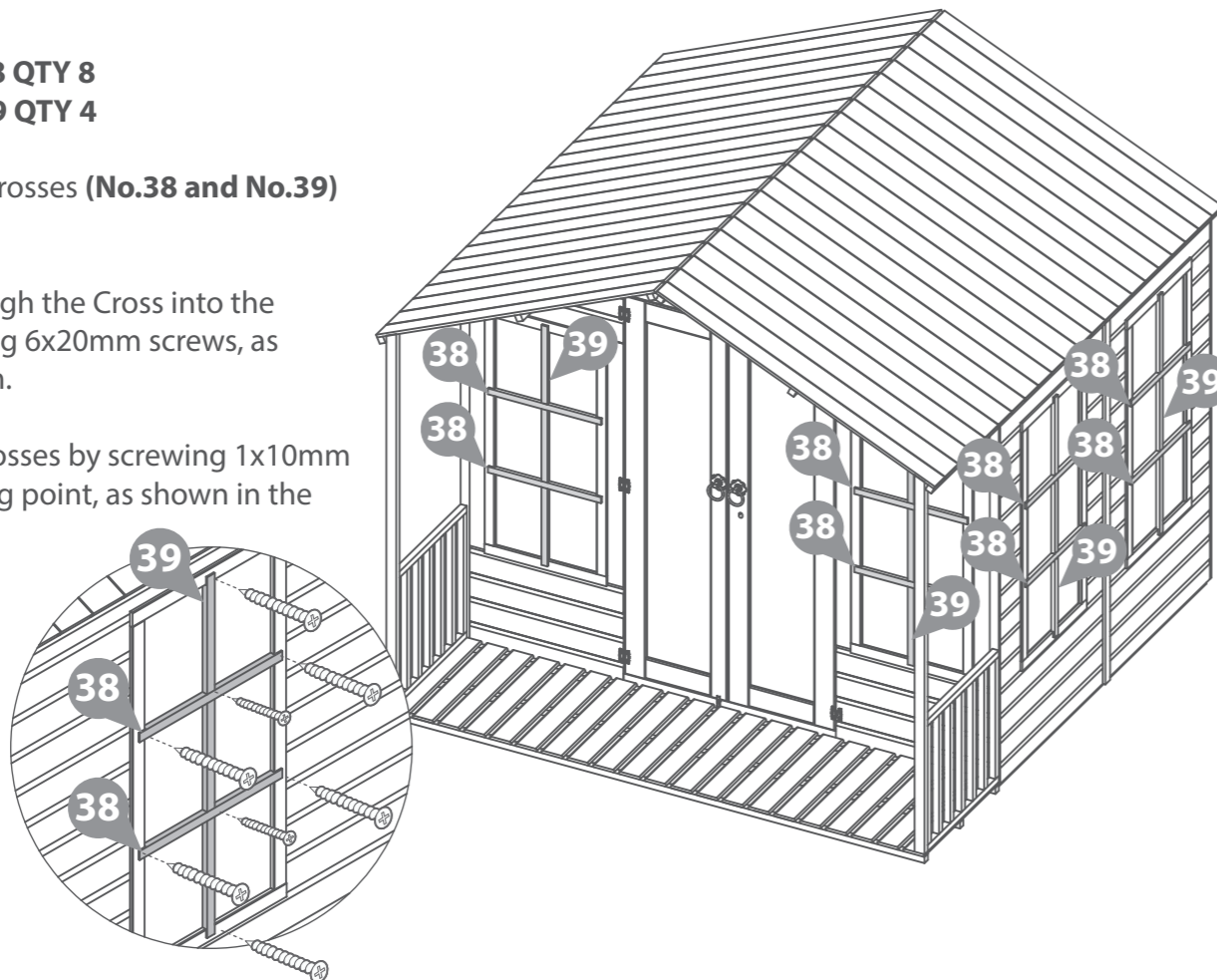

## Step 24b

Parts Needed- No.27 QTY 1

Cut the Felt (No. 27) into 3 sheets of 2510mm and lay onto the roof in the order shown in the diagram. Making sure there is 50mm of overhang on each side.

Fix to the buildings using evenly spaced felt tacks.

150 x Felt tacks.

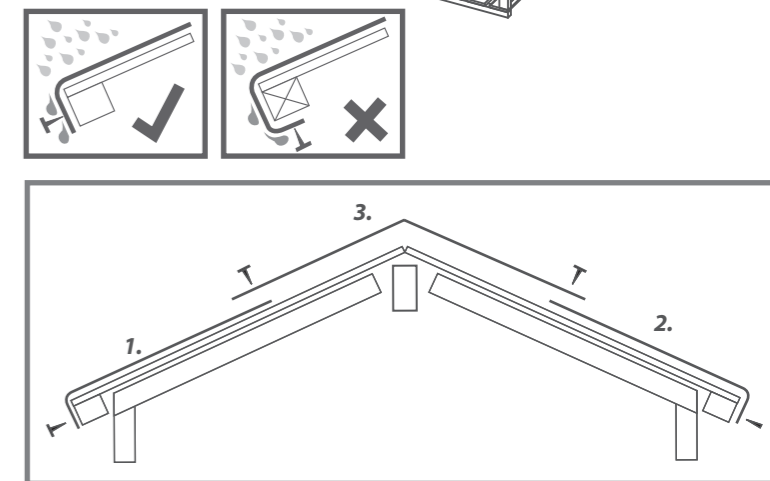
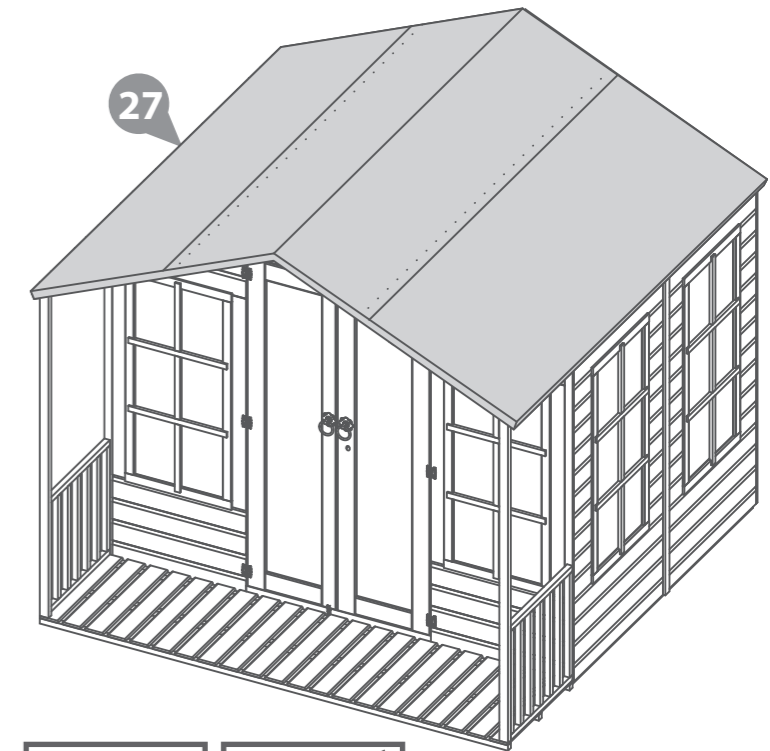
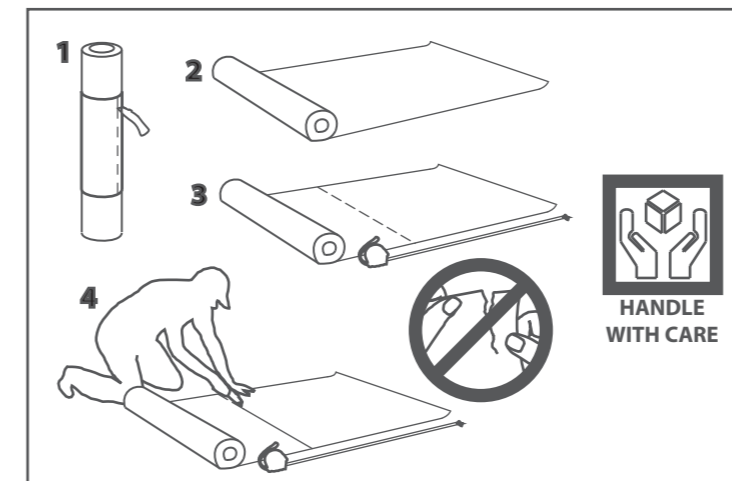

## 2ft EXTENSION PACK 8x8 Summer House

Felt Dimensions Required:  
3110mm (L) x 1000mm (W)

175 x Felt tacks.

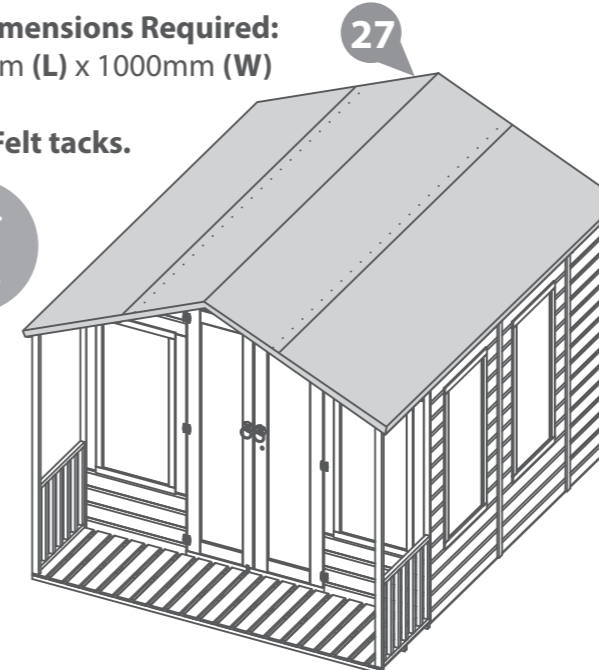

## 10x8 Summer House

Felt Dimensions Required:  
3710mm (L) x 1000mm (W)

200 x Felt tacks.

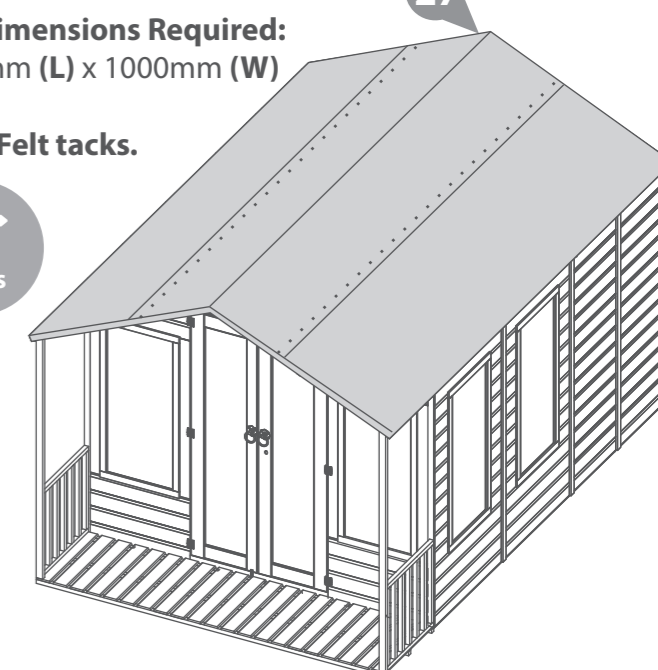



## Step 25b

Parts Needed- No.18 QTY 4  
- No.26 QTY 2

Fix Fascia (No. 18) to each end of the roof, securing with 3x30mm screws per Fascia. Ensure the screws go through the roof framing

Fix the Diamond Finials (No.26) to the Fascias using 2x30mm screws per finial.

10x30mm Screws.



Pre drill hole



30mm screw

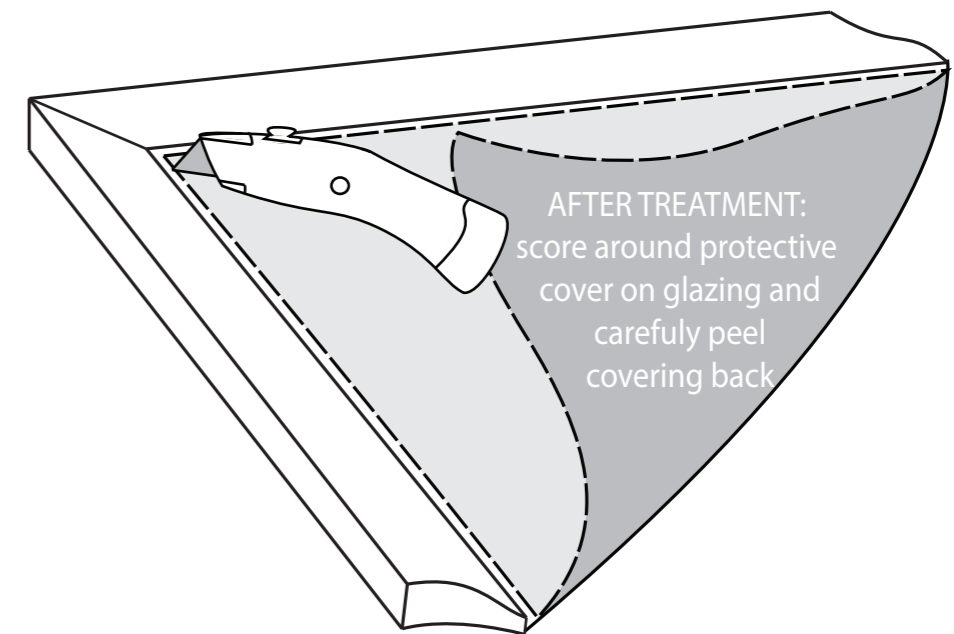
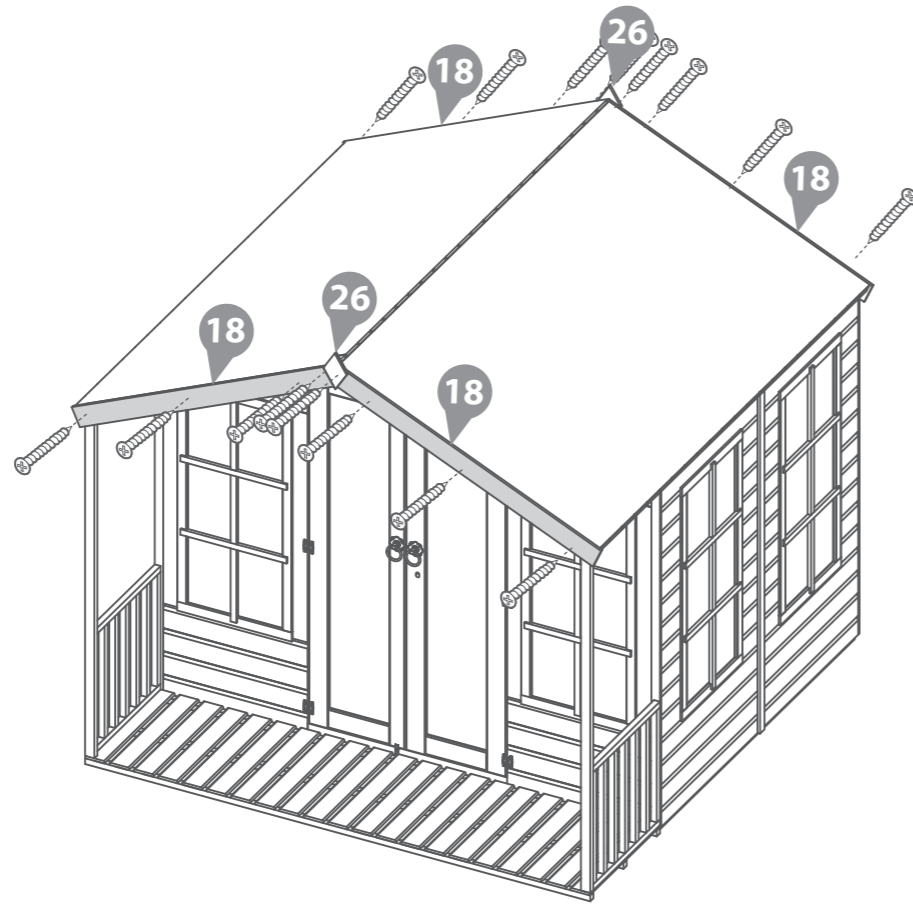

All our garden buildings have been designed and manufactured with care and attention to be the perfect addition to your outdoor space. To ensure you do get the best out of your new garden building and to increase the longevity we advise that you follow the product instructions and our manufacturer's recommendations as detailed below. Thank you for choosing a Mercia Garden product!

## 1 Choosing the most suitable location for your garden building...

A minimum of 60cm should be left around the perimeter of your garden building to allow access for maintenance, annual treatment and to allow air flow around the building.

Where possible you should avoid placing your garden building underneath large trees to prevent the tree causing damage to the building.

## 2 Preparing the base for your garden building...

All our buildings must be built on a firm, level base to ensure the longevity of the building and prevent the wood from distorting. We recommend either concrete, concrete slabs or a wooden base, such as our 'Portabase'.

The base should be slightly smaller than the external measurement of the building, i.e. the cladding should overlap the base, creating a run off for water and preventing water from pooling underneath the building.

We also recommend that the floor of the garden building is a minimum of 25mm above the surrounding ground level to avoid flooding.

## 3 After installation...

Once your garden building has been installed it will need to be treated as soon as possible and annually to prevent the timber from deteriorating and to waterproof it. This is required to maintain the anti-rot guarantee.

Dip Treated buildings - Require a preservative treatment to protect against rot and decay and a waterproof treatment to prevent water ingress

Pressure Treated buildings - Require a waterproof treatment to prevent water ingress

Log Cabins/Insulated Garden Rooms - Are supplied untreated and require a preservative and waterproofing treatment

We also recommend using a silicon sealant on the inside and outside of the windows as soon as possible after assembly and treatment to fully seal the windows.

Roofing felt/covering should be checked annually and replaced or fixed accordingly.

## 4 General maintenance and wood characteristics

As wood is a natural material it may be affected by the following:

**Shrinkage and warping** - The timber used in the construction of your garden building will have retained some of its natural moisture content. The moisture content of the timber will vary, depending upon prevailing environmental conditions, which will result in the components either naturally expanding or contracting. As the components dry out shrinkage may occur. A good waterproofing treatment from the start is the best protection to minimise the effect of moisture loss/intake.

In extended periods of very warm weather getting some moisture to the building will help the overall balance. You can do this by spraying it down lightly with a garden hose. In contrast after snow fall try to remove the snow as best as possible from the roof to prevent moisture intake and to remove the extra weight.

Top tip - using a garden brush will help you to reach the highest part of the building to remove snow and any debris left from bad weather.

**Damp and mould** - During the winter months, cold and damp conditions can result in an increased amount of moisture within your garden building, especially when used infrequently. Condensation can form on the timber and other items stored within your garden building. If left this moisture is likely to cause mould and mildew. To prevent the build-up of moisture, we recommend leaving the door or windows of your building open from time to time, to allow the fresh air to circulate. We also advise against storing wet or damp items in your garden building as this will also increase the level of moisture in the building. If mould or mildew does start to form within your building we recommend using an anti-mould cleaner to remove it and to prevent it spreading, which if left untreated could permanently damage your garden building.

**Splits, cracks and knots** - You may notice small splits and cracks in some components or holes may appear where knots shrink and fall out. This will not affect the structure of your Garden building however if you wish to fill them this can be easily done using any good quality wood filler.

**Sap** - is naturally occurring in wood and may appear in some boards of your garden building. If you wish to remove the sap, we advise waiting until it is dry and then using a sharp knife to carefully remove it. If the removal of the sap causes a hole in the timber, we recommend using a good quality wood filler to fill it.

For more handy hints and tips on how to care and maintain your garden building please refer to the MGP Customer Portal at [www.mgplogistics.co.uk](http://www.mgplogistics.co.uk)

Any further questions?

Contact our  
Customer Service  
Team on:  
01636 821215

## 1 Manufacturer's Warranty

All Mercia Garden Products are supplied with a 1 year warranty on all parts against manufacturing defects.  
This warranty does not cover movement, warping or splitting of timber products over time.

This warranty will be voided if any of the following occur:

1. The building has been customised or modified/adapted in any way.
2. The person claiming is not the original purchaser of the building.
3. Any damage has been caused by or as a result of misuse.
4. The building has not been maintained and cared for in accordance to our advisories and manufacturer's recommendations.
5. The building has not been treated annually or as per the manufacturer's recommendations, please ensure receipts are kept to validate this claim.
6. The building has not been erected, fitted or installed as per the supplier instructions.
7. The building has not been erected on a suitable sized firm flat, solid level concrete/slab base or placed on pressure treated bearers.
8. The building is or has been placed with 2 feet (60cm) of any obstructions (walls, trees, plants, fences etc.) which can allow moisture to penetrate the timber.
9. The roofing felt has been incorrectly fitted or damaged allowing water ingress, or not properly maintained.
10. Any windows and joints have not been sealed, inside and out, with silicone or other watertight sealant.
11. Any timber has been cut, pierced or drilled without subsequent application of approved cut-end treatment.

## 2 Anti-rot Guarantee

Mercia Garden Products offer a 10 year anti-rot guarantee on all dip treated (a preparatory treatment) and 15 years on all pressure treated products. This guarantee covers solid timber against rot, decay, blue stain and insect attack.

To validate the guarantee the building must be treated with a recognised wood preserver/water proof top coat (as detailed within manufacturer's recommendations) as soon as possible after assembly and annually thereafter.

This guarantee does not cover movement, warping or splitting of timber products over time.

This guarantee will be voided if any of the following occur:

1. The building has been customised or modified/adapted in any way.
2. The person claiming is not the original purchaser of the building.
3. Any damage is caused by or as a result of misuse.
4. The building has not been maintained and cared for in accordance to our advisories and manufacturer's recommendations.
5. The building has not been treated annually or as per the manufacturer's recommendations, please ensure receipts are kept to validate this claim.
6. The building has not been erected, fitted or installed as per the supplier instructions.
7. The building has not been erected on a suitable sized firm flat, solid level concrete/slab base or placed on pressure treated bearers.
8. The building is or has been placed with 2 feet (60cm) of any obstructions (walls, trees, plants, fences etc.) which can allow moisture to penetrate the timber.
9. The roofing felt has been incorrectly fitted or damaged allowing water ingress, or not properly maintained.
10. Any windows and joints have not been sealed, inside and out, with silicone or other watertight sealant.
11. Any timber has been cut, pierced or drilled without subsequent application of approved cut-end treatment.