

**02DTSHPN0606SFD2W-V1-PEFC**  
**6x6 Pent Playhouse**



**WARNING: Only for domestic use**  
**Not suitable for children under 36 months due to small gaps and danger of falling from heights.**  
**To be used under direct supervision of an adult**

## BEFORE YOU START PLEASE READ THE INSTRUCTIONS CAREFULLY

- Check the pack and make sure you have all the parts listed in the parts list provided.
- When you are ready to start, make sure you have the right tools at hand (not supplied) including a Phillips screwdriver, Flathead screwdriver, Stanley knife, Wood saw, Step ladder, Hammer, Spirit level and a Drill with 2mm bit.
- Ensure there is plenty of space and a clean dry area for assembly.
- Ensure you have enough time to build the product to ensure the building is water tight.

## TIMBER

As with all natural materials, timber can be affected during various weather conditions. For the duration of heavy or extended periods of rain, swelling of the wood panels may occur. Warping of the wood may also occur during excessive dry spells due to natural processes. Unfortunately, these processes cannot be avoided but can be helped. It is suggested that the outdoor building is sprayed with water during extended periods of hot weather and sheltered as much as possible during rain or snow.

Our buildings are pre treated with a water based treatment\*\*; this only helps to prevent discolouration whilst in stock. To validate your guarantee and ensure longevity of the product, it is ESSENTIAL the building is treated with a suitable preservative in accordance with the manufacturers recommendations. Care must be taken to ensure the product is placed on a suitable base. We recommended using a suitable protection for your playhouse. As the product is destined for use by children, a water based treatment for childrens toys is ESSENTIAL.

We also recommend treating the building prior to construction.

## POSITIONING YOUR PLAYHOUSE

When thinking about where the building and base is going to be constructed: Ensure that there will be access to all sides for maintenance work and annual treatment.

We recommend a **minimum space of 2m around a playhouse**, away from any structure or obstructions such as fences, garages, houses, overhanging branches, washing lines or electrical wires.

It is recommended that the position of the Playhouse is **not in direct sunlight**.

**Activity toys such as swings and slides for towers shall not be installed over concrete, asphalt or any hard surface.**

## BUILDING A BASE

Ensure the base is level and is built on firm ground, to prevent distortion, checking with a spirit level. Refer to diagrams for the base dimensions. The base should be slightly smaller than the external measurement of the building, i.e. The cladding should overlap the base, creating a run off for water. It is also recommended that the floor be at least 25mm above the surrounding ground level to avoid flooding.

## TYPES OF BASE

- Concrete 75mm laid on top of 75mm hard-core.
- Slabs laid on 50mm of sharp sand.
- Wooden base.



## WARNING

- ONLY SUITABLE FOR DOMESTIC USE.
- TO BE USED UNDER DIRECT SUPERVISION OF AN ADULT.
- THIS PRODUCT SHOULD NOT BE MODIFIED IN ANY WAY. ANY MODIFICATIONS SHOULD BE DETERMINED BY THE MANUFACTURER AND CARRIED OUT ACCORDING TO THE INSTRUCTIONS.
- DO NOT ALLOW YOUR CHILD TO PLAY WITH ANY COMPONENT PARTS PRIOR TO ASSEMBLY.
- MAX AGE OF 14 YEARS.
- THIS TOY IS FOR OUTDOOR USE ONLY.
- USE A WATER BASED TREATMENT THAT IS EN71 TESTED

## CAUTION

Wood is a natural product and can change post manufacture. So despite every effort being made to ensure the material used are cut and machined to a clean and smooth finish, care must be taken when handling the product and preparing for use by your child.

Any areas of concern, in the play areas, can be rubbed over with sandpaper to achieve a smoother finish. Alternatively, call the customer service department who will be happy to arrange replacement panels/parts.



All buildings should be erected by atleast two adults.  
**DO NOT ALLOW CHILDREN TO ASSIST.**



Winter = High Moisture = Expansion  
 Summer = Low Moisture = Contraction



2mm Drill bit  
 12mm CSK

To prevent damage during assembly, you **MUST** pilot drill all screw holes and **ensure all screw heads are countersunk.**



For ease of assembly, you will need a tape measure to check dimensions of components.

*Whilst all products manufactured are made to the highest standards of Safety and in the case of childrens products independently tested to EN71, we cannot accept responsibility for your safety whilst erecting this product.*

## \*\*Protim Aquatan T5 (621)\*\*

Your building has been dip treated with **Aquatan**.

Aquatan is a water-based concentrate which is diluted with water, the building has been treated by the correct application of Aquatan solution and then allowed to dry.

Aquatan is a decorative finish to colour the wood, which is applied industrially to timber fence panels and garden buildings.

**Aquatan undiluted contains:** boric acid, sodium hydroxide 32% solution, aqueous mixture of sodium dioctyl sulphosuccinat and alcohols: 2, 4, 6-trichlorophenol.

**In all instances for assistance with your product, please contact customer care on : 01636 821215 or customerservice@merciagp.co.uk**

**Mercia Garden Products Limited,**  
**Sutton On Trent,**  
**Newark,**  
**Nottinghamshire,**  
**NG23 6QN**



## Playhouse Options:

Take a look at the different playhouse options below which refers to the instruction leaflets required to build each option.

Model	Build Instructions Required
<b>6x6 Pent Playhouse</b> <i>SI-002-001-0072</i>	02DTSHPN0606SFD2W-V1-PEFC ( <i>Playhouse</i> )
<b>6x6 Pent Playhouse &amp; Tower</b> <i>SI-002-001-0114</i>	02DTSHPN0606SFD2W-V1-PEFC ( <i>Playhouse</i> ) 02DTTWR0707-V1-PEFC ( <i>Tower</i> )
<b>6x6 Pent Playhouse, Tower &amp; Slide</b> <i>SI-002-001-0115</i>	02DTSHPN0606SFD2W-V1-PEFC ( <i>Playhouse</i> ) 02DTTWR0707-V1-PEFC ( <i>Tower</i> )
<b>6x6 Pent Playhouse, Tower, Slide &amp; Swing</b> <i>SI-002-001-0106</i>	02DTSHPN0606SFD2W-V1-PEFC ( <i>Playhouse</i> ) 02DTTWR0707-V1-PEFC ( <i>Tower</i> ) 02PATINCSWA-V1-PEFC ( <i>Swing Set</i> )

**6x6 Pent Playhouse, Tower, Slide & Swing**

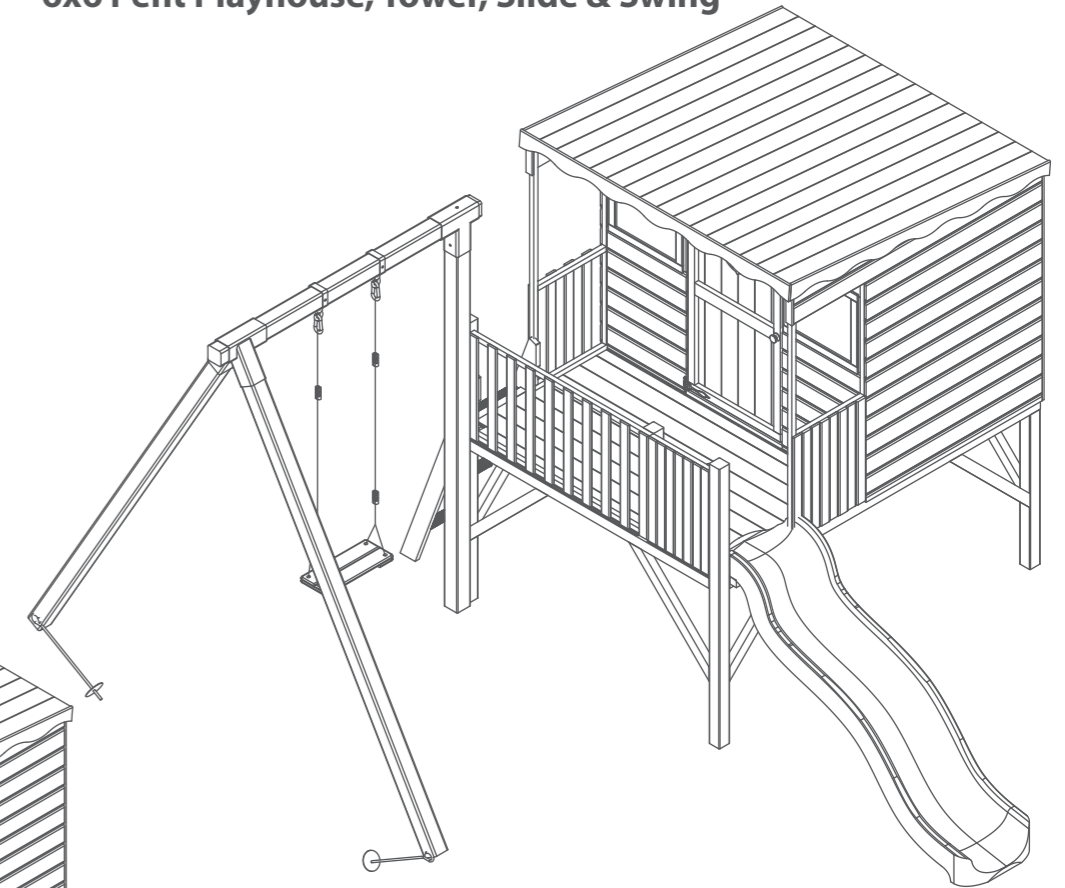

**6x6 Pent Playhouse, Tower & Slide**

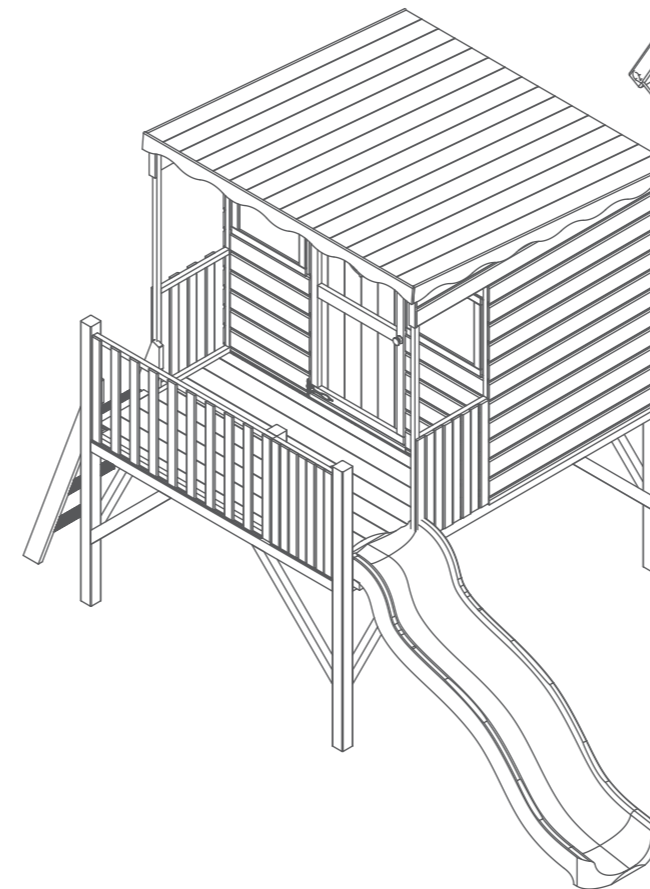

**6x6 Pent Playhouse & Tower**

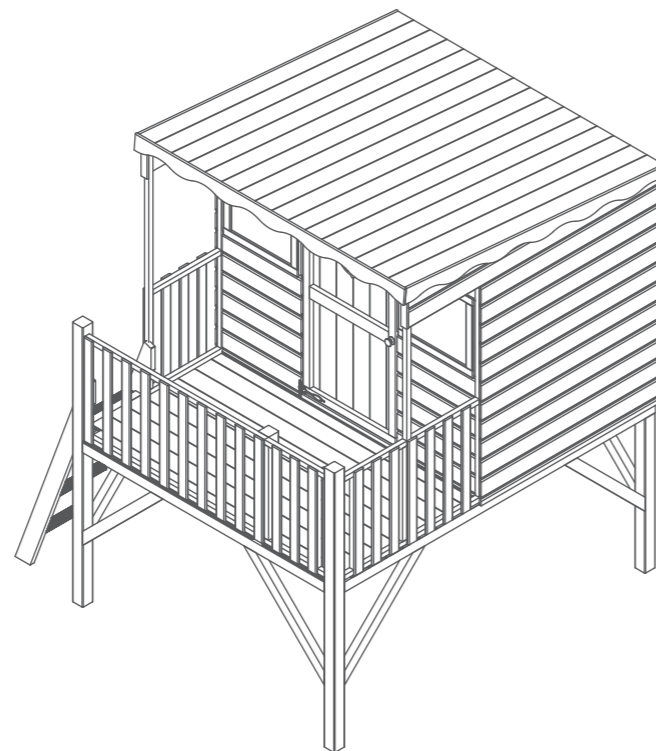

**6x6 Pent Playhouse**

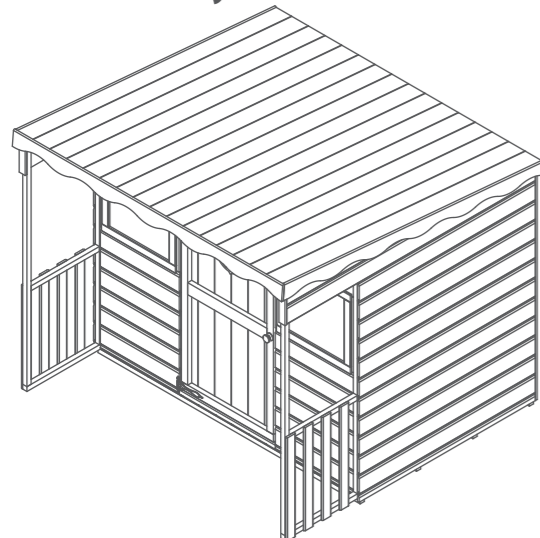

**DO NOT ALLOW YOUR CHILD TO PLAY WITH ANY COMPONENT PARTS PRIOR TO ASSEMBLY.**

Look for the symbols and follow the safety guidelines below.



Ensure screw heads are subflush and sand down any splinters created.



Ensure the screws are fixed squarely and do not protrude.



12mm gap surrounding the door.



50kg per user

**Overall Dimensions:**

Width = 1808mm  
Depth = 1761mm  
Height = 1558mm

**Base Dimensions:**

Width = 1760mm  
Depth = 1668mm

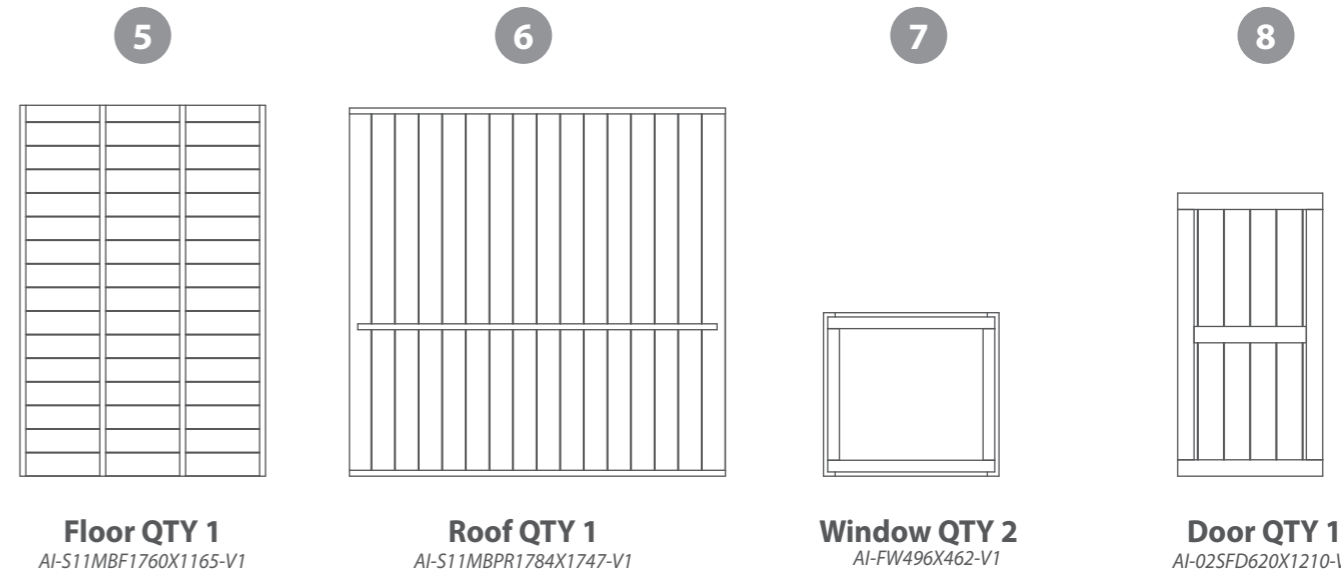
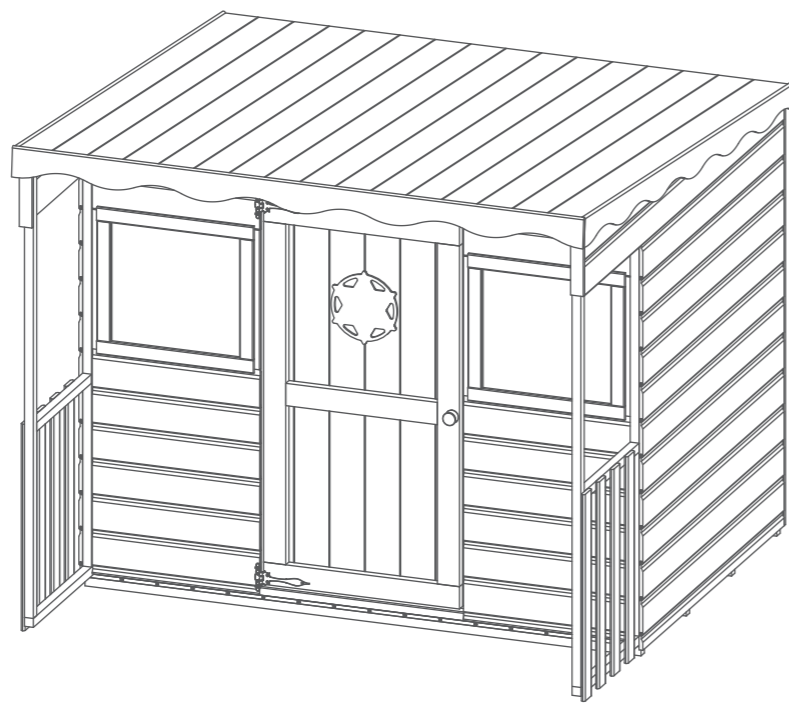

- 9 **Fascia - 12x95x1808mm QTY 1**  
FAS1295-1808mm
- 10 **Fascia - 12x95x1747mm QTY 2**  
FAS1295-1747mm
- 11 **Cover Trim - 12x40x1360mm QTY 2**  
S1240-1360mm
- 12 **Cover Trim - 12x40x205mm QTY 2**  
S1240-205mm
- 13 **Sheriff's Badge / Butterfly QTY 1**  
PI-04-0060 / PI-04-0015
- 14 **Ply Door Stop QTY 2**  
PLY TRIANGLE
- 15 **T-Hinge QTY 2**  
PI-07-0113
- 16 **Wooden Handle QTY 1**  
PI-04-0024
- 17 **Window Block QTY 4**  
PI-07-0011
- 18 **Corner Brace QTY 2**  
PI-07-0012
- 19 **Felt**
- 20 **Door Spacer Strip QTY 4**  
SR1260-100mm

**Building Content** 02DTSHPN0606SFD2W-V1-PEFC :

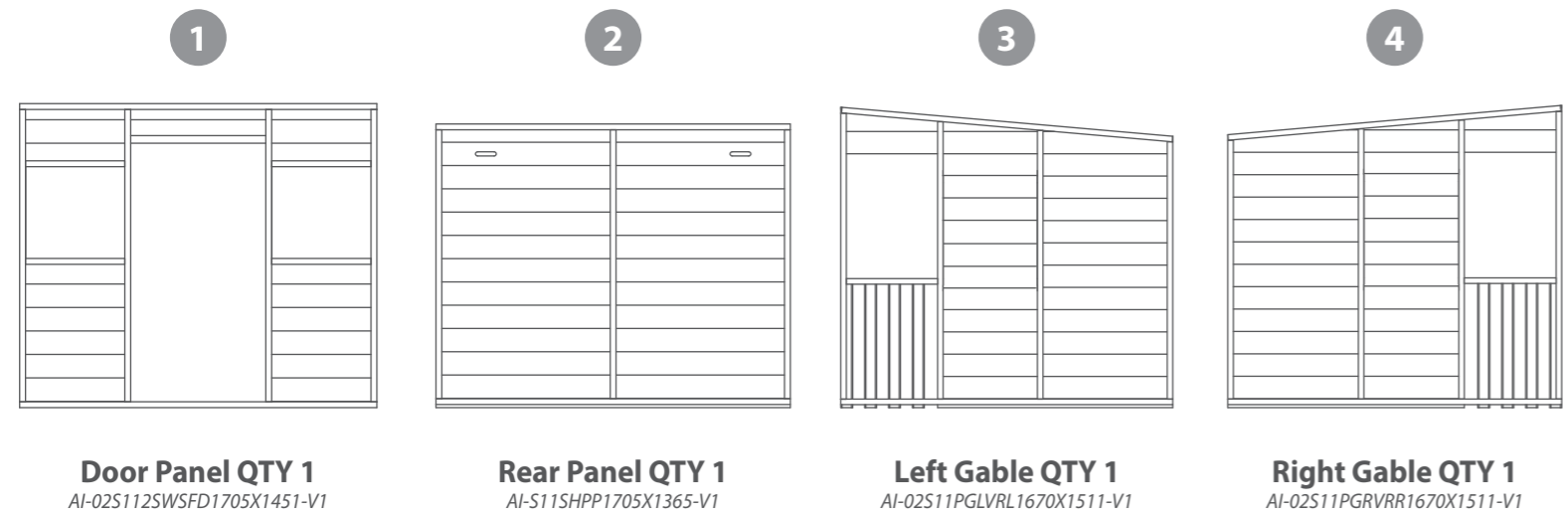

**Nail Bag**

	50mm Screw x 42		10mm Screw x 2
	30mm Screw x 46		Felt Tacks x 65
	30mm Black Screw x 14		

**DO NOT ALLOW YOUR CHILD TO PLAY WITH ANY COMPONENT PARTS PRIOR TO ASSEMBLY.**

**Pre Assembly**

Before assembling remove the transportation blocks from the bottom of each panel.

Take care removing the blocks as to not damage the panels. Tap with a flat headed screwdriver and hammer.

Dispose of the blocks once removed.

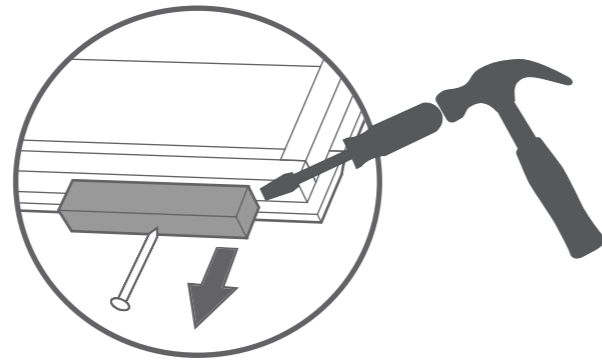

**Step 1**

**Parts needed - 1 & 7 & 17**

Fix the Window Blocks (No. 17) to the Windows (No. 7) as shown with 1x30mm screw.

Place one Window (No. 7) into each window hole in the Door Panel (No.1), fix by screwing through the Window Blocks (No. 17) with 2x30mm screws per window block as shown.

**12x30mm screws.**

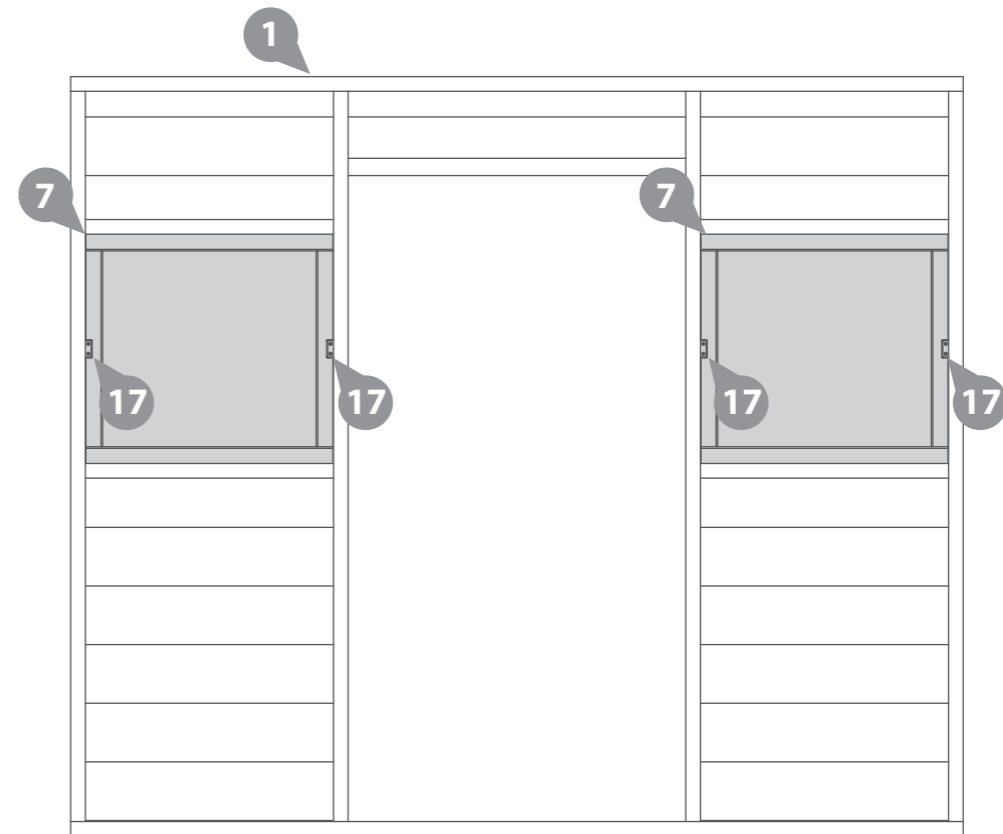
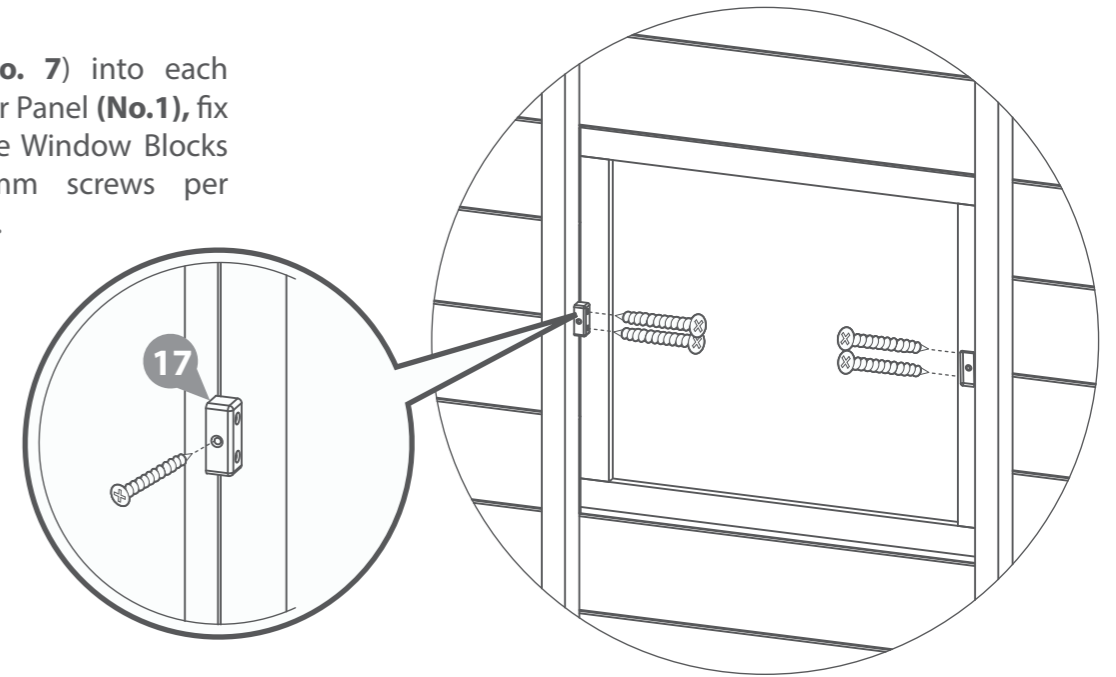

REGISTER FOR YOUR  
**ANTI-ROT**  
GUARANTEE TODAY

PLEASE SCAN HERE:



DO NOT ALLOW YOUR CHILD TO PLAY WITH ANY COMPONENT PARTS PRIOR TO ASSEMBLY.

**Step 2**

Parts needed - 1 & 8 & 15 & 20

**A** Flip the Door Panel (No. 1) over so the boards are facing upwards and place the Door (No. 8) within the door aperture as shown. Position two Door Spacer Strips (No. 20) within the top gap between the door (No. 8) and the door panel (No. 1). Next position two Door Spacer Strips (No. 20) down the hinge side between the door (No. 8) and the door panel (No. 1).

The 12mm gap is to prevent serious injury should a child's fingers become trapped between the door and the door panel.

**B** Place the Hinges (No. 15) at the top and bottom of the door (No. 8) and using 7x30mm black screws per hinge, fix the hinge to the door and the door panel.

14x30mm black screws

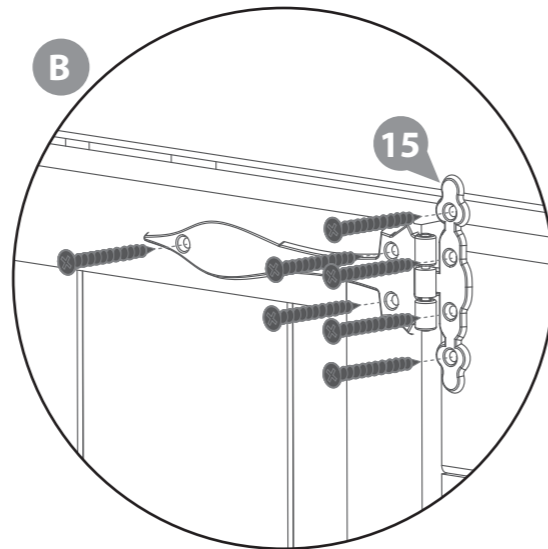
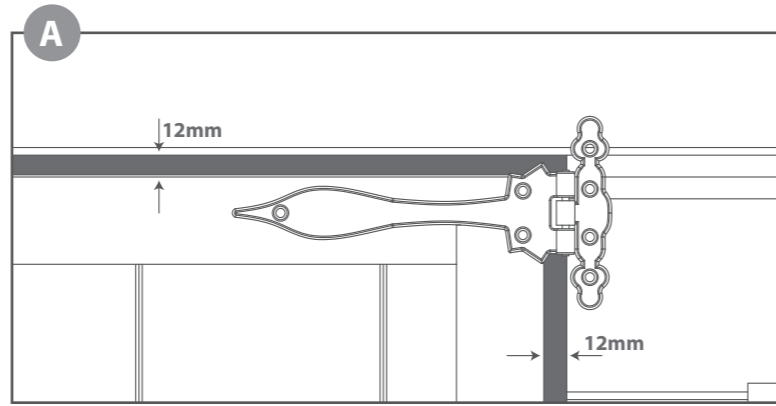
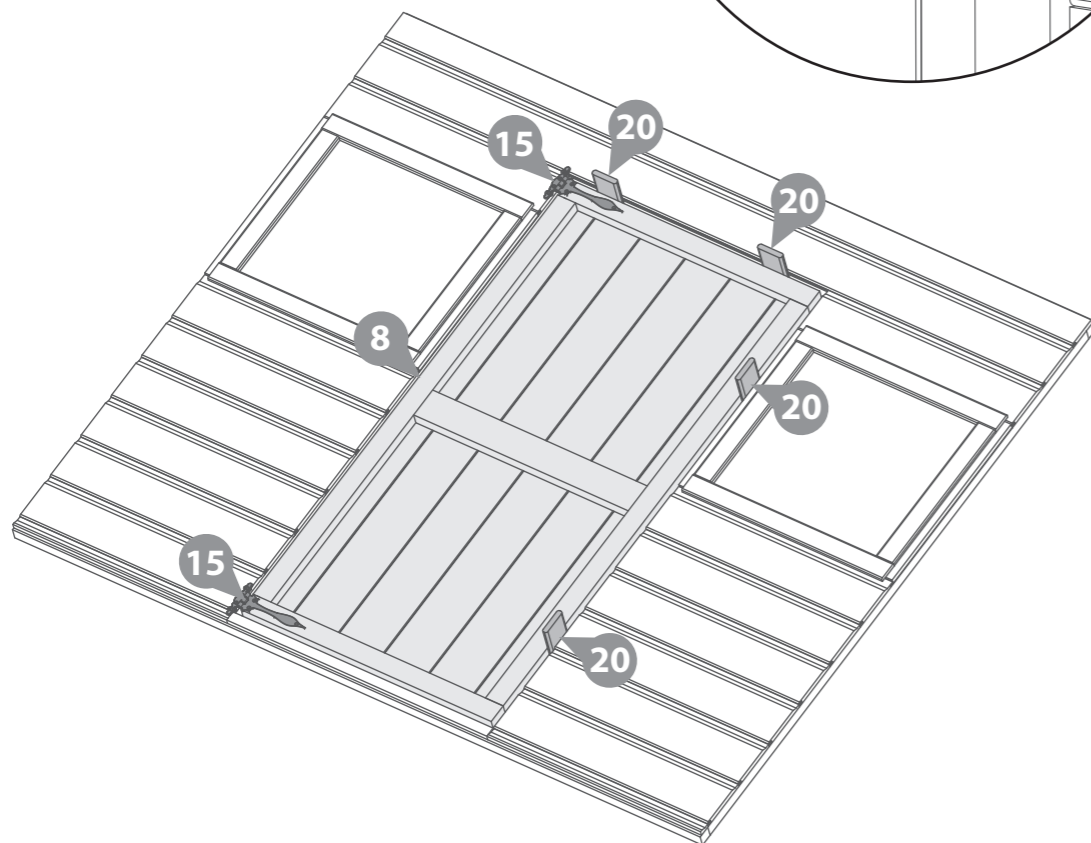
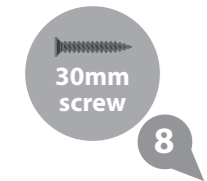

**Step 3**

Parts needed - 5

Place the Floor (No.5) on to a firm and level base, ensure base has suitable drainage free from areas where standing water can collect. (See front page on base requirements).

\*\*Please note: if you have purchased a Tower (02DTTWR0707-V1-PEFC), please construct your playhouse onto the Tower Base rather than the floor.

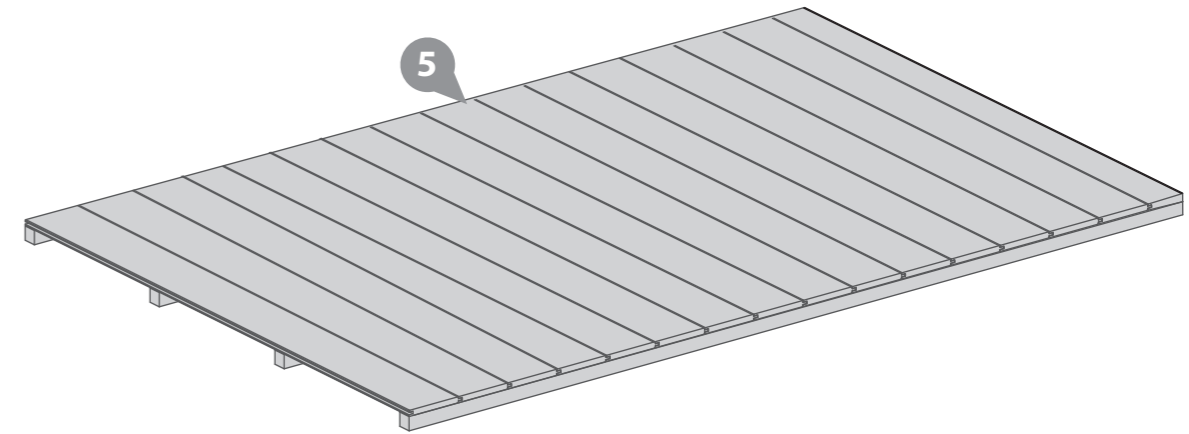

**Step 4**

Parts needed - 2 & 4

Place the Rear Panel (No.2) and the Right Gable (No.4) on top of the floor, ensuring the panels are positioned centrally on the floor, as shown in the illustration.

Fix together by screwing through the framing of the Rear Panel (No.2) into the framing of the Right Gable (No.4) using 3x50mm screws.

Do not secure the building to the Floor until the Roof is fitted.

3x50mm screws.

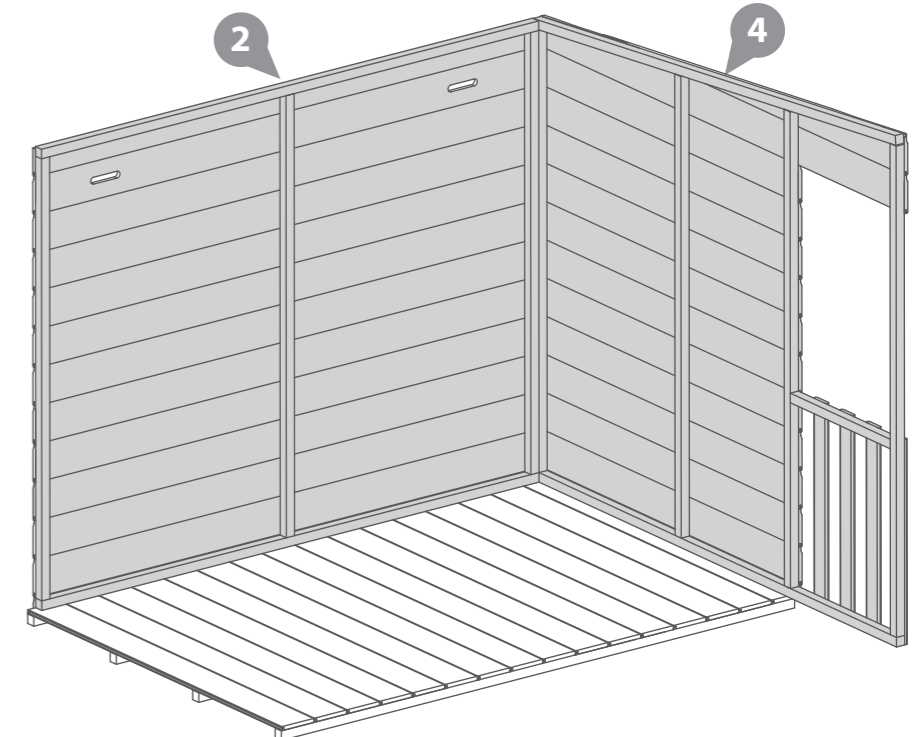
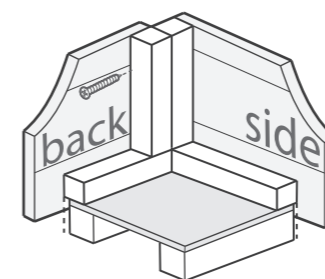

DO NOT ALLOW YOUR CHILD TO PLAY WITH ANY COMPONENT PARTS PRIOR TO ASSEMBLY.

**Step 5**  
Parts needed - 1 & 3

Place the Door Panel (No.1) and the Left Gable (No.3) on top of the floor, ensuring the panels are positioned centrally on the floor, as shown in the illustration.

Fix together by screwing through the framing of the Door Panel (No.1) and Rear Panel (No.2) into the framing of the Left Gable (No.3) and Right Gable (No.4) using 3x50mm screws.

**Do not secure the building to the Floor until the Roof is fitted.**

9x50mm screws.

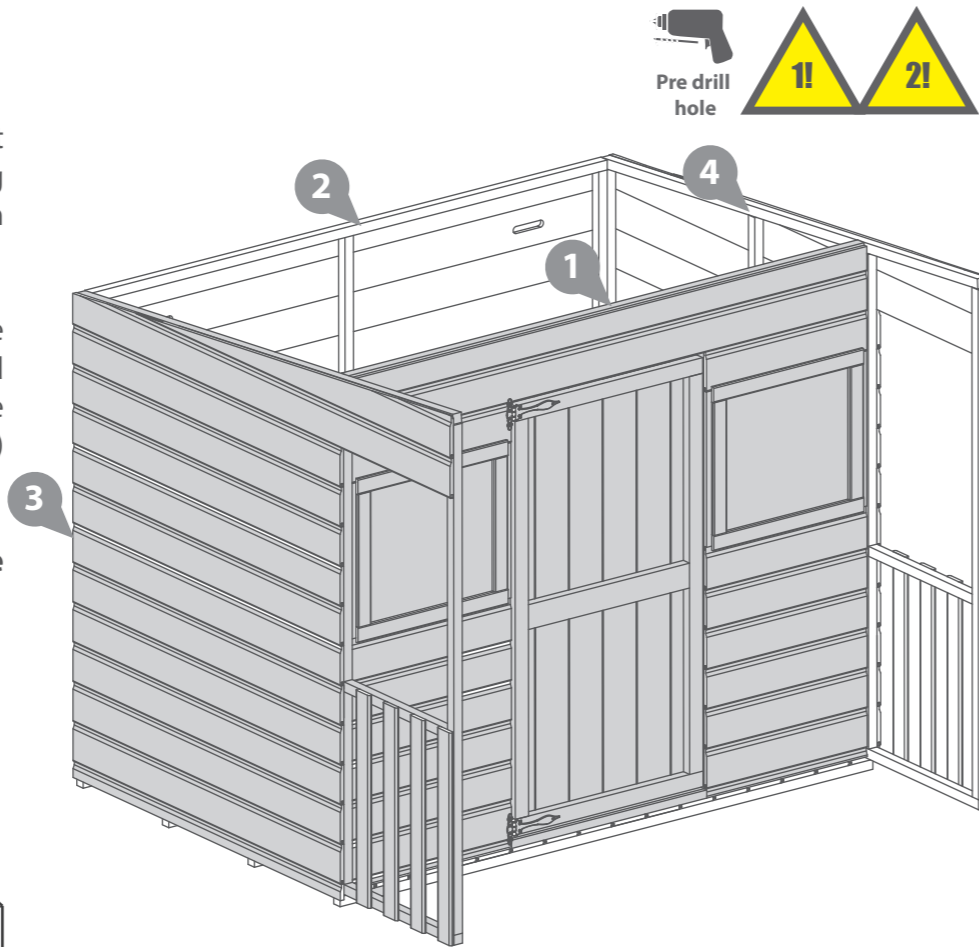
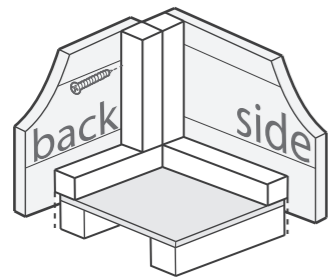

**Step 6**  
Parts needed - 6 & 18

**A** Locate the Roof (No.6) on top of the playhouse, ensuring the central roof bar is in line with the central upright framing of the gables (internally), as shown in the illustration.

**B** Fix by screwing down through the Roof (No.6) into the Panel framing below using 12x50mm screws.

**C** Locate one Corner brace (No. 18) per end of the central framing, and secure using 4x30mm screws per brace.

**Do not secure the building to the Floor until the Roof is fitted.**

12x50mm screws  
8x30mm screws

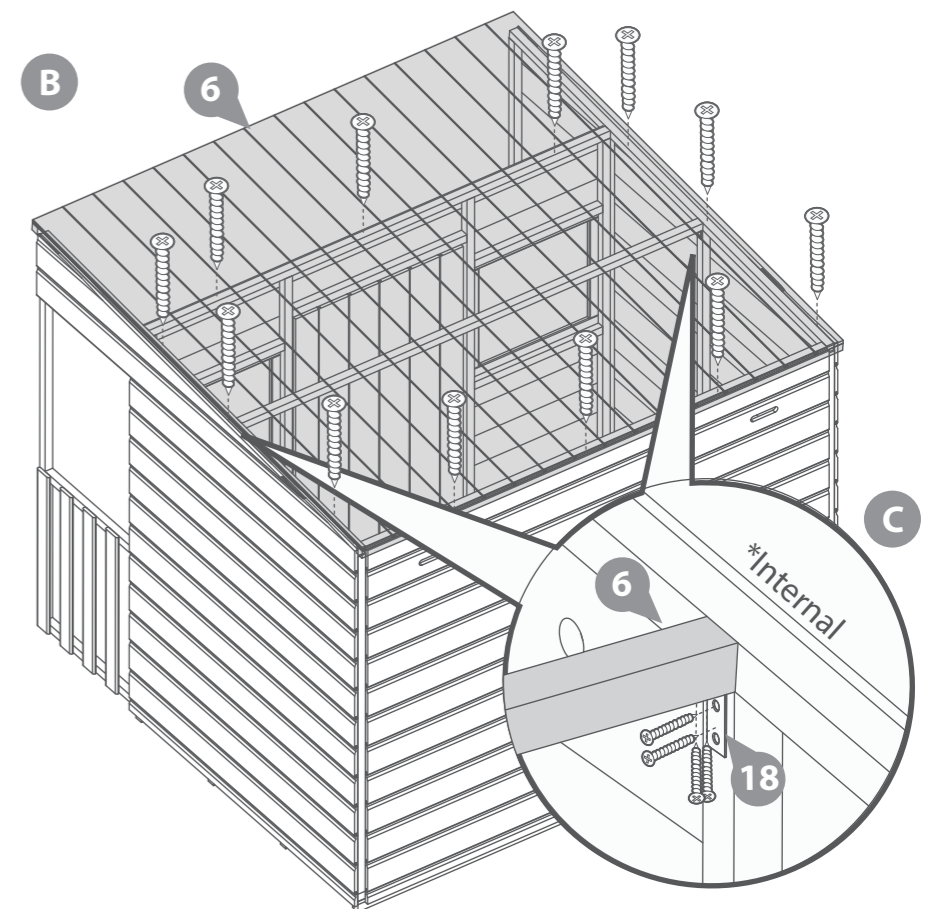
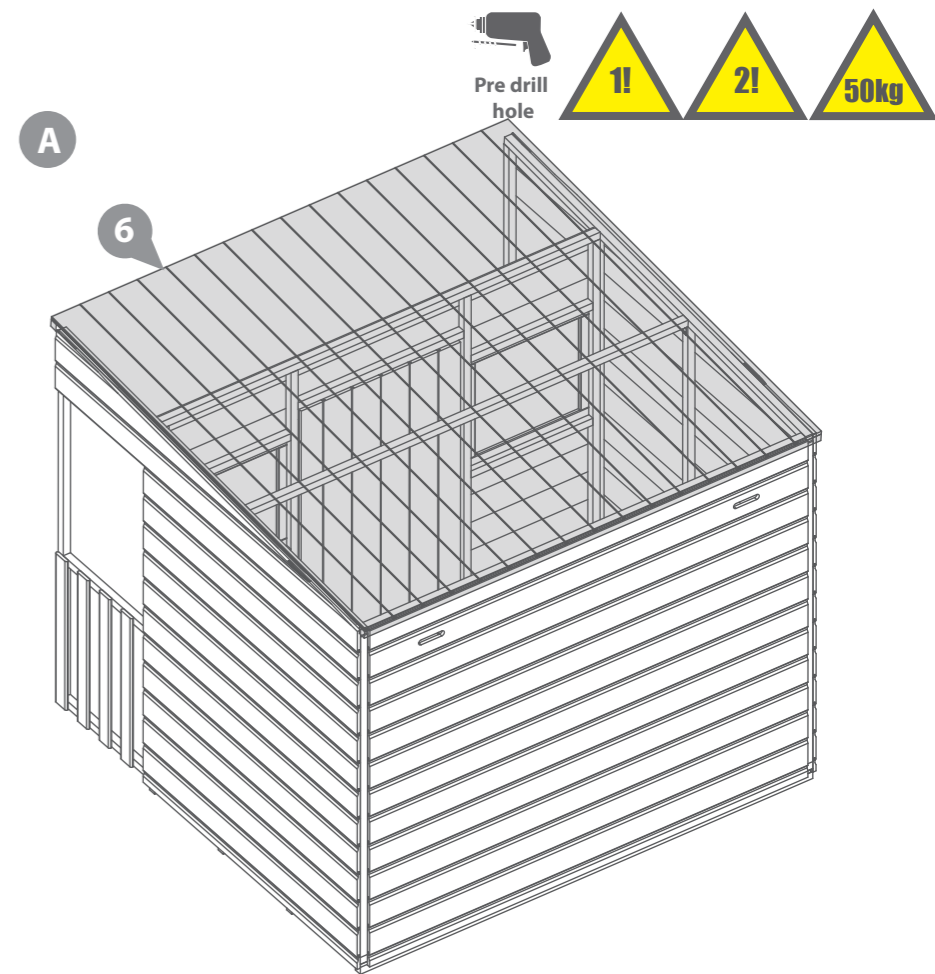

**DO NOT ALLOW YOUR CHILD TO PLAY WITH ANY COMPONENT PARTS PRIOR TO ASSEMBLY.**

**Step 7**

Once the roof is fitted and the building is square, secure the building to the Floor, using 50mm screws in alignment with the floor joists.

**18x50mm Screws**

50mm screw

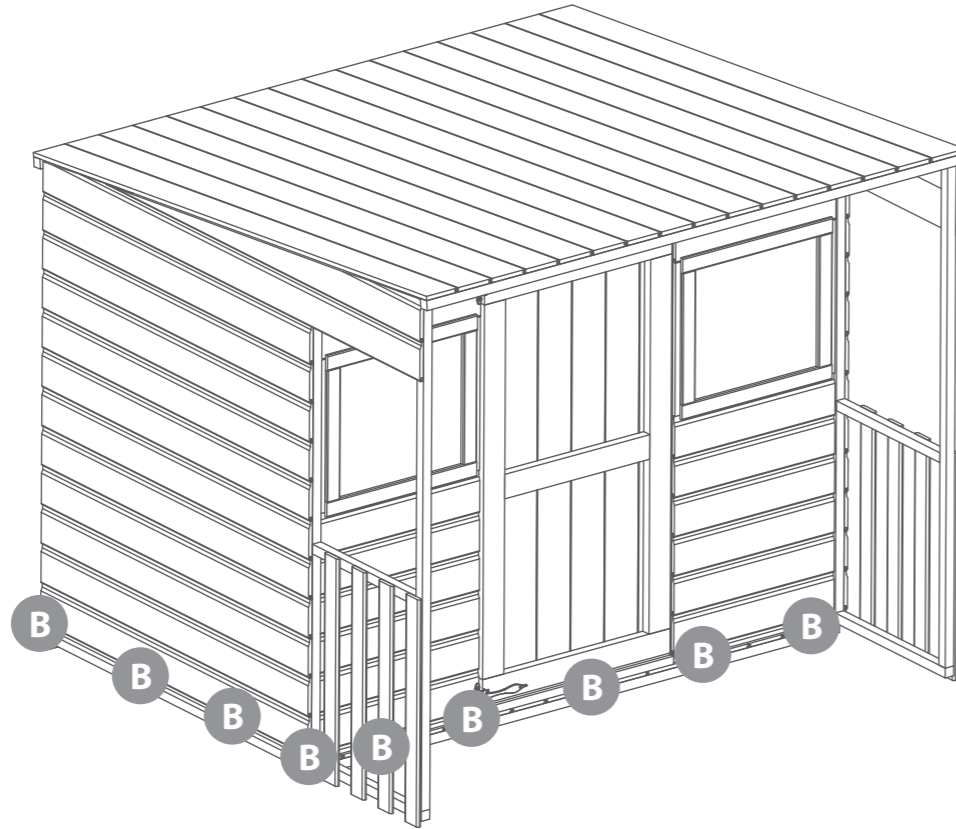
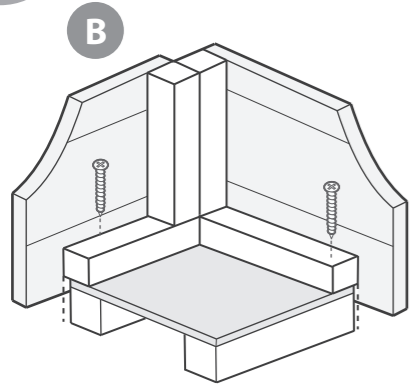

**Step 8**

Cut the felt (No. 19) into 2 sheets measuring: **1900mm (L) X 1000mm (W)** and lay onto roof. Start at the bottom of the roof and work your way up so that rain pours over the top of the laps and not under them. Ensure there is a 50mm overhang around the sides.

Fix into place using 60x felt tacks at 100mm intervals.

**Felt Size: 1900mm**

**65 x Felt Tacks**

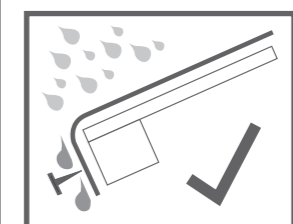
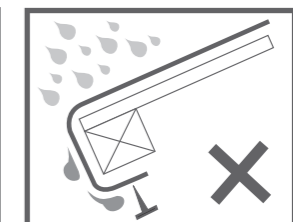
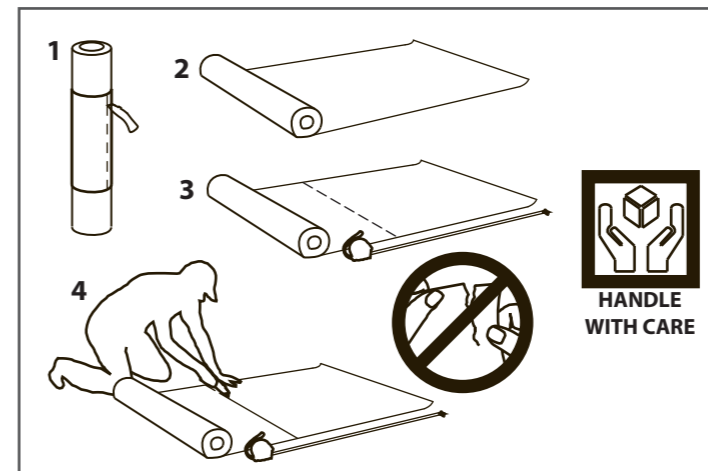
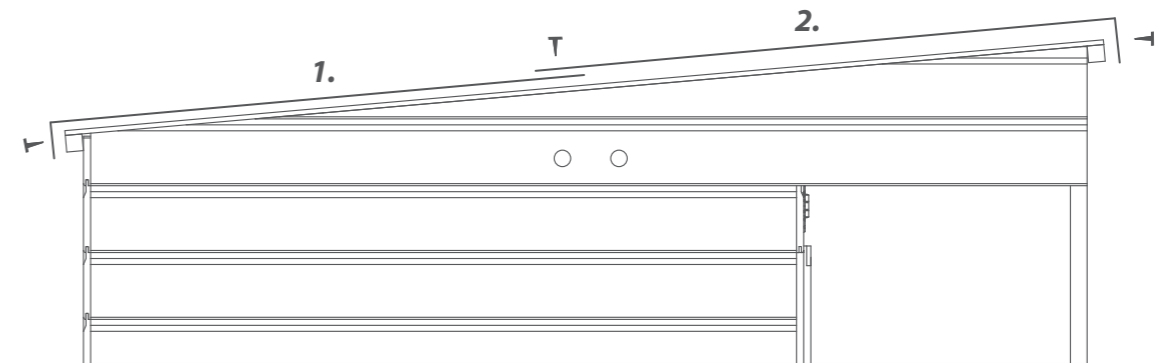
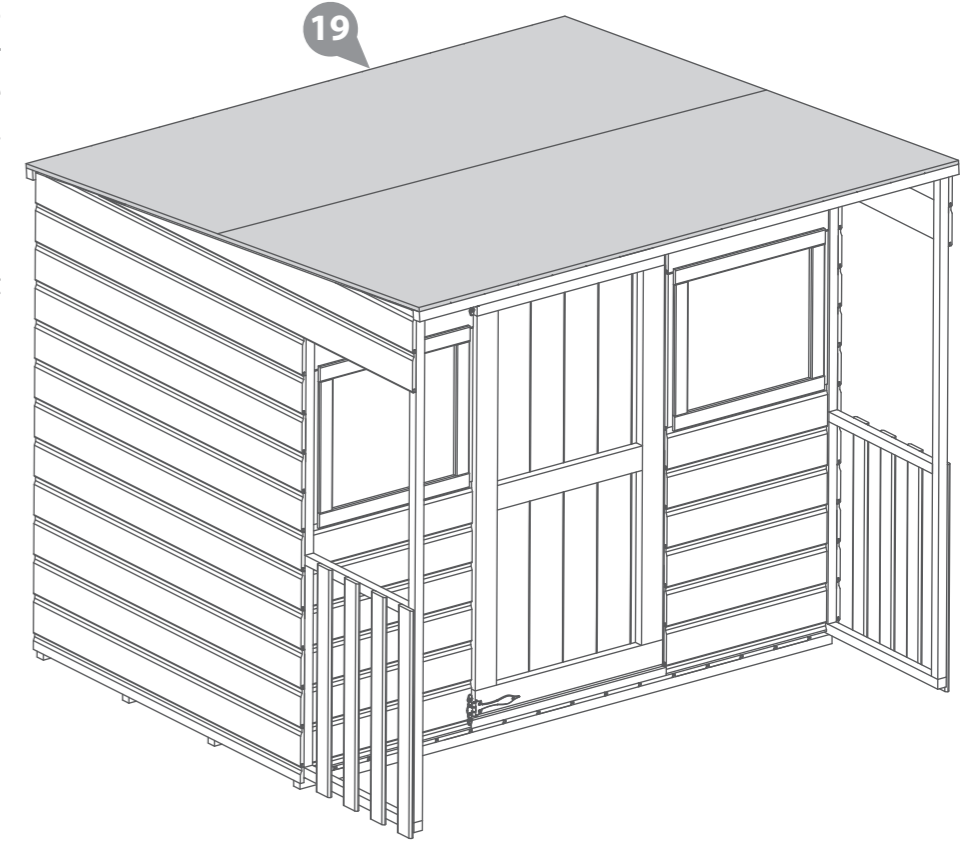

**DO NOT ALLOW YOUR CHILD TO PLAY WITH ANY COMPONENT PARTS PRIOR TO ASSEMBLY.**

**Step 9**  
**Parts needed - 11 & 12**

Locate the Cover Trims (No. 11) onto the back of the playhouse. Fix in place using 3x30mm screws per Cover trim.

Locate the Cover Trims (No. 12) onto the front of the playhouse. Fix in place using 2x30mm screws per Cover trim.

**10x30mm Screws**

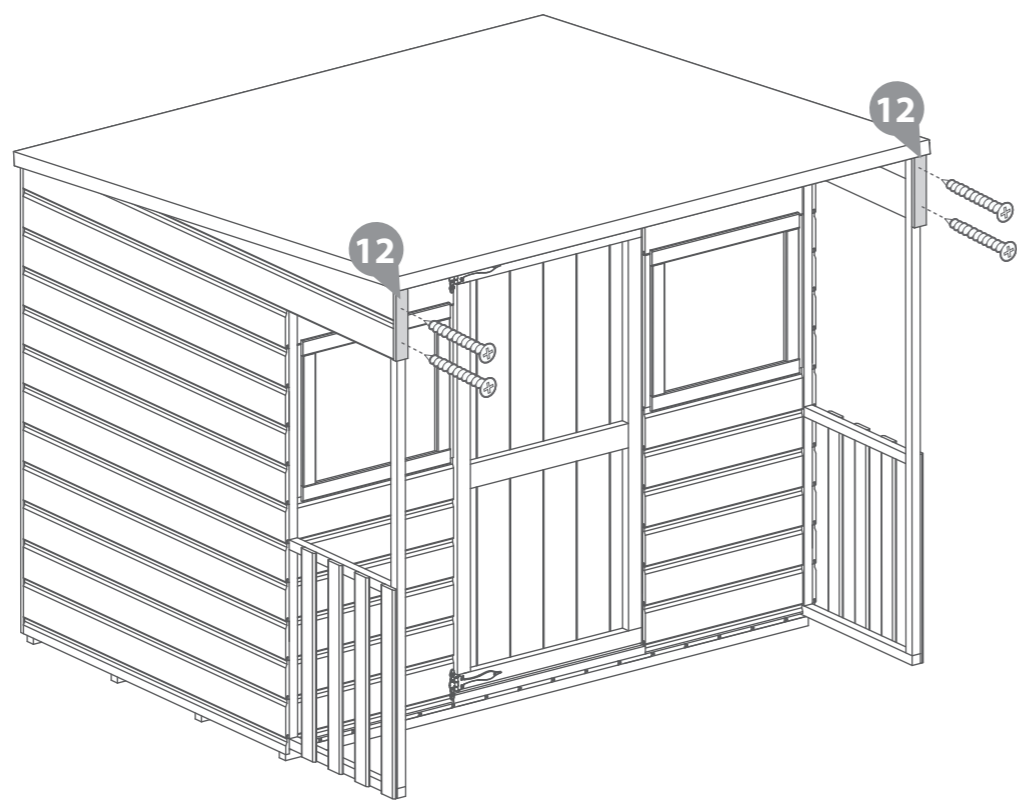
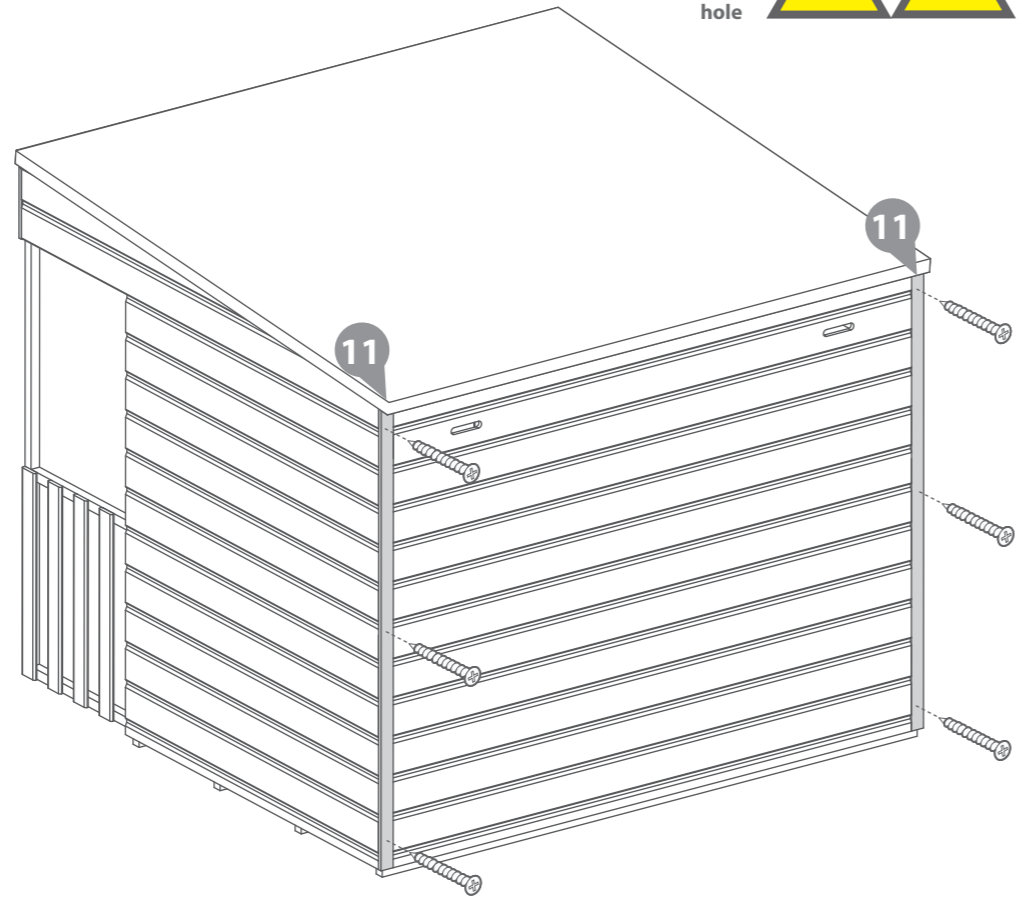

**Step 10**  
**Parts needed - 9 & 10**

Locate the Fascia (No.9) to the front of the building. Fix in place using 4x30mm screws.

Locate the Fascias (No.10) to either side of the building. Fix in place using 3x30mm screws per Fascia.

**10x30mm Screws**

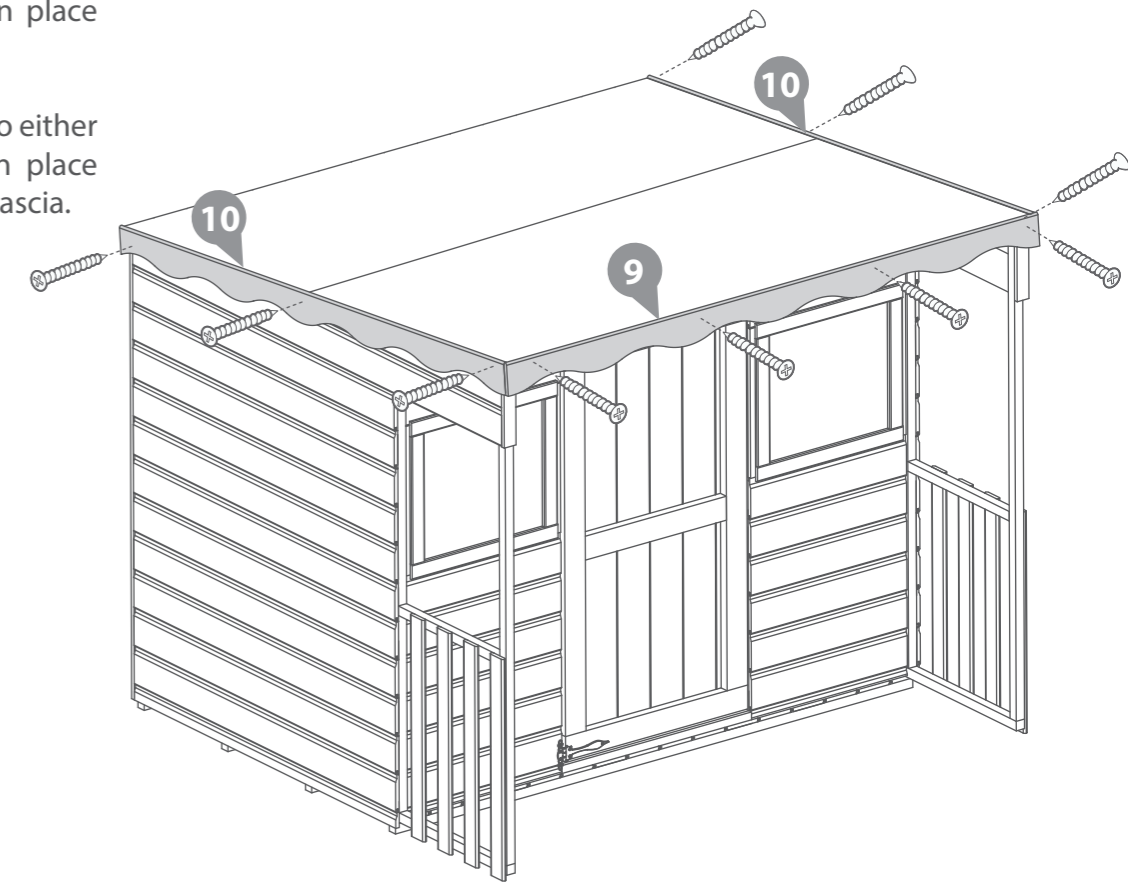

**DO NOT ALLOW YOUR CHILD TO PLAY WITH ANY COMPONENT PARTS PRIOR TO ASSEMBLY.**



**Step 11**

**Parts needed - 13 & 14 & 16**

**A** Locate the Wooden Door Handle (No. 16) onto the outside of the door. Fix in place by hand, screwing through the door with the screw attached to the door handle.

**B** Fix the Ply Door Stop (No. 14) to the inside of the Door Panel at the top and bottom of the door opening using 3x30mm screws as shown per door stop.

**C** Fix the Sheriffs badge / Butterfly (No. 13) onto to the door using 2x10mm screws.

*\*Please note: the same method is used for attaching both the sheriffs badge and butterfly.*

**6x30mm Screws**  
**2x10mm Screws**

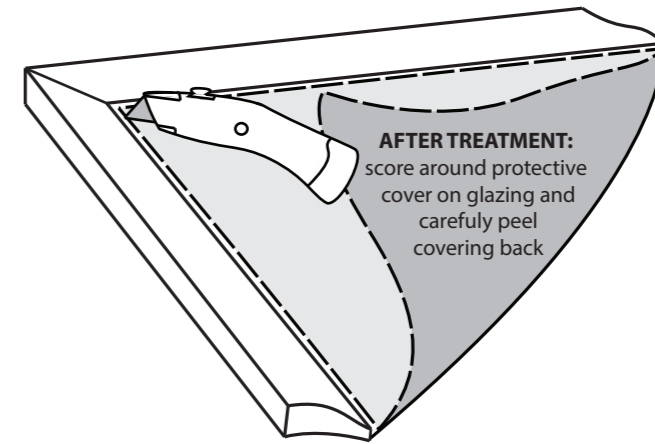
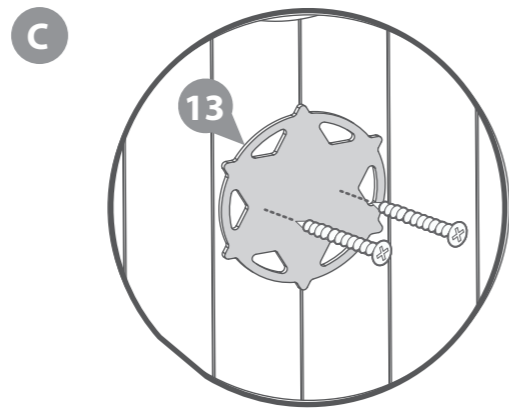
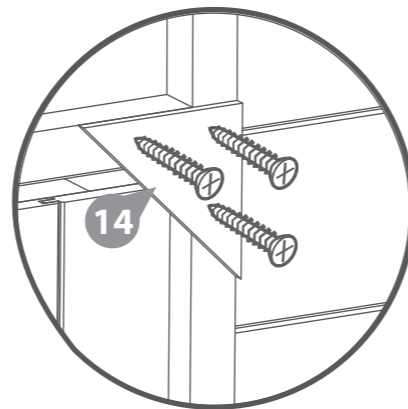
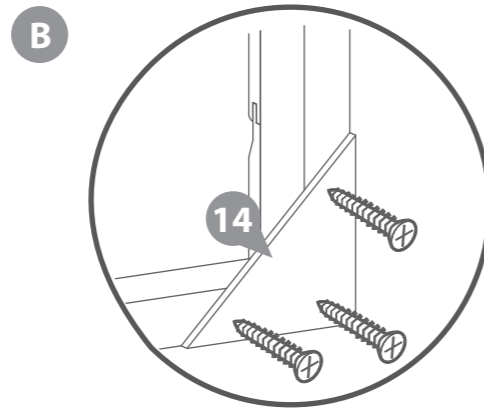
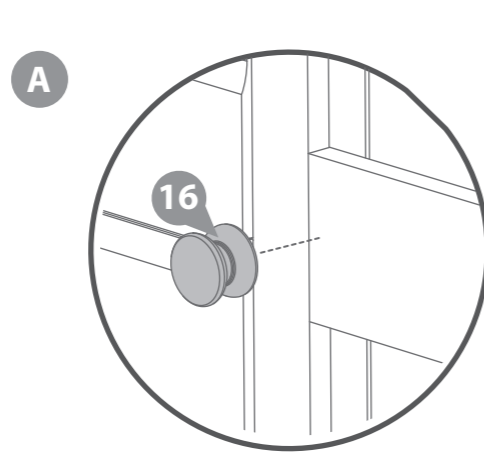
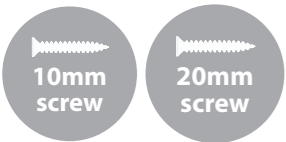

**Playhouse Maintenance:**

It is recommended that the following checks and maintenance are carried out at the beginning of each season as well as at regular intervals during the usage season.

- Check all nuts /bolts/ screws for tightness and tighten when required.
- Check for movement / opening of wood giving rise to protrusion of nail heads and tips.
- Check hinges.
- Replace defective parts in accordance with the manufacturers instructions.
- Check any crossbeams, suspensions and anchors.
- If a swing is included; check the swing seat, chains and ropes.

**IF THESE CHECKS ARE NOT CARRIED OUT THE ACTIVITY TOY COULD BECOME A HAZARD**

**DO NOT ALLOW YOUR CHILD TO PLAY WITH ANY COMPONENT PARTS PRIOR TO ASSEMBLY.**

All our garden buildings have been designed and manufactured with care and attention to be the perfect addition to your outdoor space. To ensure you do get the best out of your new garden building and to increase the longevity we advise that you follow the product instructions and our manufacturer's recommendations as detailed below. Thank you for choosing a Mercia Garden product!

## 1 Choosing the most suitable location for your garden building...

A minimum of 60cm should be left around the perimeter of your garden building to allow access for maintenance, annual treatment and to allow air flow around the building.

Where possible you should avoid placing your garden building underneath large trees to prevent the tree causing damage to the building.

## 2 Preparing the base for your garden building...

All our buildings must be built on a firm, level base to ensure the longevity of the building and prevent the wood from distorting. We recommend either concrete, concrete slabs or a wooden base, such as our 'Portabase'.

The base should be slightly smaller than the external measurement of the building, i.e. the cladding should overlap the base, creating a run off for water and preventing water from pooling underneath the building.

We also recommend that the floor of the garden building is a minimum of 25mm above the surrounding ground level to avoid flooding.

## 3 After installation...

Once your garden building has been installed it will need to be treated as soon as possible and annually to prevent the timber from deteriorating and to waterproof it. This is required to maintain the anti-rot guarantee.

Dip Treated buildings - Require a preservative treatment to protect against rot and decay and a waterproof treatment to prevent water ingress

Pressure Treated buildings - Require a waterproof treatment to prevent water ingress

Log Cabins/Insulated Garden Rooms - Are supplied untreated and require a preservative and waterproofing treatment

We also recommend using a silicon sealant on the inside and outside of the windows as soon as possible after assembly and treatment to fully seal the windows.

Roofing felt/covering should be checked annually and replaced or fixed accordingly.

## 4 General maintenance and wood characteristics

As wood is a natural material it may be affected by the following:

**Shrinkage and warping** - The timber used in the construction of your garden building will have retained some of its natural moisture content. The moisture content of the timber will vary, depending upon prevailing environmental conditions, which will result in the components either naturally expanding or contracting. As the components dry out shrinkage may occur. A good waterproofing treatment from the start is the best protection to minimise the effect of moisture loss/intake.

In extended periods of very warm weather getting some moisture to the building will help the overall balance. You can do this by spraying it down lightly with a garden hose. In contrast after snow fall try to remove the snow as best as possible from the roof to prevent moisture intake and to remove the extra weight.

Top tip - using a garden brush will help you to reach the highest part of the building to remove snow and any debris left from bad weather.

**Damp and mould** - During the winter months, cold and damp conditions can result in an increased amount of moisture within your garden building, especially when used infrequently. Condensation can form on the timber and other items stored within your garden building. If left this moisture is likely to cause mould and mildew. To prevent the build-up of moisture, we recommend leaving the door or windows of your building open from time to time, to allow the fresh air to circulate. We also advise against storing wet or damp items in your garden building as this will also increase the level of moisture in the building. If mould or mildew does start to form within your building we recommend using an anti-mould cleaner to remove it and to prevent it spreading, which if left untreated could permanently damage your garden building.

**Splits, cracks and knots** - You may notice small splits and cracks in some components or holes may appear where knots shrink and fall out. This will not affect the structure of your Garden building however if you wish to fill them this can be easily done using any good quality wood filler.

**Sap** - is naturally occurring in wood and may appear in some boards of your garden building. If you wish to remove the sap, we advise waiting until it is dry and then using a sharp knife to carefully remove it. If the removal of the sap causes a hole in the timber, we recommend using a good quality wood filler to fill it.

For more handy hints and tips on how to care and maintain your garden building please refer to the MGP Customer Portal at [www.mgplogistics.co.uk](http://www.mgplogistics.co.uk)

Any further questions?

Contact our  
Customer Service  
Team on:  
01636 821215

## 1 Manufacturer's Warranty

All Mercia Garden Products are supplied with a 1 year warranty on all parts against manufacturing defects.  
This warranty does not cover movement, warping or splitting of timber products over time.

This warranty will be voided if any of the following occur:

1. The building has been customised or modified/adapted in any way.
2. The person claiming is not the original purchaser of the building.
3. Any damage has been caused by or as a result of misuse.
4. The building has not been maintained and cared for in accordance to our advisories and manufacturer's recommendations.
5. The building has not been treated annually or as per the manufacturer's recommendations, please ensure receipts are kept to validate this claim.
6. The building has not been erected, fitted or installed as per the supplier instructions.
7. The building has not been erected on a suitable sized firm flat, solid level concrete/slab base or placed on pressure treated bearers.
8. The building is or has been placed with 2 feet (60cm) of any obstructions (walls, trees, plants, fences etc.) which can allow moisture to penetrate the timber.
9. The roofing felt has been incorrectly fitted or damaged allowing water ingress, or not properly maintained.
10. Any windows and joints have not been sealed, inside and out, with silicone or other watertight sealant.
11. Any timber has been cut, pierced or drilled without subsequent application of approved cut-end treatment.

## 2 Anti-rot Guarantee

Mercia Garden Products offer a 10 year anti-rot guarantee on all dip treated (a preparatory treatment) and 15 years on all pressure treated products. This guarantee covers solid timber against rot, decay, blue stain and insect attack.

To validate the guarantee the building must be treated with a recognised wood preserver/water proof top coat (as detailed within manufacturer's recommendations) as soon as possible after assembly and annually thereafter.

This guarantee does not cover movement, warping or splitting of timber products over time.

This guarantee will be voided if any of the following occur:

1. The building has been customised or modified/adapted in any way.
2. The person claiming is not the original purchaser of the building.
3. Any damage is caused by or as a result of misuse.
4. The building has not been maintained and cared for in accordance to our advisories and manufacturer's recommendations.
5. The building has not been treated annually or as per the manufacturer's recommendations, please ensure receipts are kept to validate this claim.
6. The building has not been erected, fitted or installed as per the supplier instructions.
7. The building has not been erected on a suitable sized firm flat, solid level concrete/slab base or placed on pressure treated bearers.
8. The building is or has been placed with 2 feet (60cm) of any obstructions (walls, trees, plants, fences etc.) which can allow moisture to penetrate the timber.
9. The roofing felt has been incorrectly fitted or damaged allowing water ingress, or not properly maintained.
10. Any windows and joints have not been sealed, inside and out, with silicone or other watertight sealant.
11. Any timber has been cut, pierced or drilled without subsequent application of approved cut-end treatment.



REGISTER FOR YOUR  
**ANTI-ROT**  
GUARANTEE TODAY

PLEASE SCAN HERE:

