

# General Instructions

Please retain product label and instructions for future reference

**01OVLPA10DDGP-V1**

**OVERLAP APEX SHED 5X10, 10X10, 15X10, 20X10**

## BEFORE YOU START PLEASE READ INSTRUCTIONS CAREFULLY

- Check the pack and make sure you have all the parts listed.
- When you are ready to start, make sure you have the right tools at hand (not supplied) including a Phillips screwdriver, Stanley knife, Wood saw, Step ladder, Hammer and a Drill with 2mm bit.
- Ensure there is plenty of space and a clean dry area for assembly.

## LOCATION FOR YOUR GARDEN BUILDING

A minimum of 60cm should be left around the perimeter of your garden building to allow access for maintenance, annual treatment and to allow air flow around the building.

Where possible you should avoid placing your garden building underneath large trees to prevent the tree causing damage to the building.

## TIMBER

As with all natural materials, timber can be affected during various weather conditions. For the duration of heavy or extended periods of rain, swelling of the wood panels may occur. Warping of the wood may also occur during excessive dry spells due to an interior moisture loss. Unfortunately, these processes cannot be avoided but can be helped. It is suggested that the outdoor building is sprayed with water during extended periods of warm sunshine and sheltered as much as possible during rain or snow.

Once your garden building has been installed it will need to be treated as soon as possible and annually to prevent the timber from deteriorating and to waterproof it. This is required to maintain the anti-rot guarantee.

Dip Treated buildings - Require a preservative treatment to protect against rot and decay and a waterproof treatment to prevent water ingress  
Pressure Treated buildings - Require a waterproof treatment to prevent water ingress  
Log Cabins - Are supplied untreated and require a preservative and waterproofing treatment.

## BUILDING A BASE

When thinking about where the building and base is going to be constructed:  
Ensure that there will be access to all sides for maintenance work and annual treatment.

Ensure the base is level and is built on firm ground, to prevent distortion. Refer to diagrams for the base dimensions, The base should be slightly smaller than the external measurement of the building, i.e. The cladding should overlap the base, creating a run off for water. It is also recommended that the floor be at least 25mm above the surrounding ground level to avoid flooding.

## TYPES OF BASE

- Concrete 75mm laid on top of 75mm hard-core.
- Slabs laid on 50mm of sharp sand.

**Whilst all products manufactured are made to the highest standards of Safety and in the case of childrens products independently tested to EN71 level, we cannot accept responsibility for your safety whilst erecting or using this product.**



x2

All building's should be erected by two adults



Winter = High Moisture = Expansion  
Summer = Low Moisture = Contraction



2mm Drill bit

For ease of assembly, you **MUST** pilot drill all screw holes and ensure all screw heads are countersunk.



## CAUTION

Every effort has been made during the manufacturing process to eliminate the prospect of splinters on rough surfaces of the timber. You are strongly advised to wear gloves when working with or handling rough sawn timber.

## \*\*Protim Aquatan T5 (621)\*\*

Your building has been dip treated with **Aquatan**.

Aquatan is a water-based concentrate which is diluted with water, the building as been treated by the correct application of Aquatan solution and then allowed to dry.

Aquatan is a decorative finish to colour the wood, which is applied industrially to timber fence panels and garden buildings.

**Aquatan undiluted contains:** boric acid, sodium hydroxide 32% solution, aqueous mixture of sodium dioctyl sulphosuccinat and alcohols: 2, 4, 6-trichlorophenol.



REGISTER FOR YOUR  
**ANTI-ROT**  
GUARANTEE TODAY

PLEASE SCAN HERE:



For assistance please contact customer care on: 01636 821215

**Mercia Garden Products Limited,  
Sutton On Trent,  
Newark,  
Nottinghamshire,  
NG23 6QN**

[www.mercia garden products.co.uk](http://www.mercia garden products.co.uk)

# 01OVLPA10DDGP-V1 - OVERLAP APEX SHED 5X10, 10X10, 15X10, 20X10

The building you have purchased can be built in various ways. Within this document it is demonstrated on how to construct your building whether it is a 5x10, 10x10, 15x10 or 20x10.



## 5X10 Apex

**Overall Dimensions:**  
Width = 3097mm  
Depth = 1548mm  
Height = 2255mm

**Base Dimensions:**  
Width = 2974mm  
Depth = 1487mm

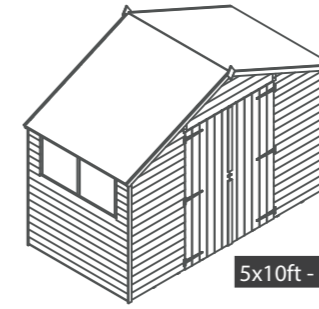

5x10ft - 1 FIXED WINDOW

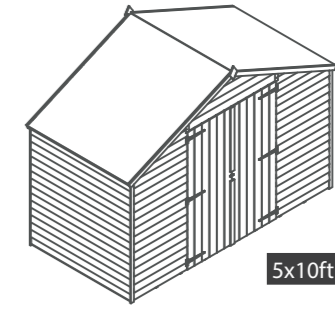

5x10ft - NO WINDOWS

## 10X10 Apex

**Overall Dimensions:**  
Width = 3097mm  
Depth = 3038mm  
Height = 2255mm

**Base Dimensions:**  
Width = 2974mm  
Depth = 2974mm

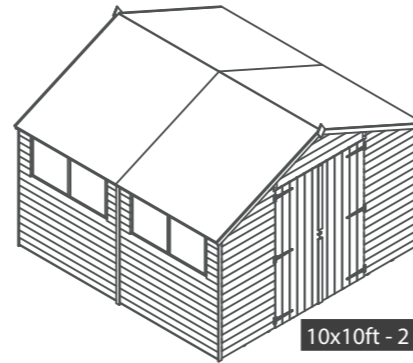

10x10ft - 2 FIXED WINDOWS

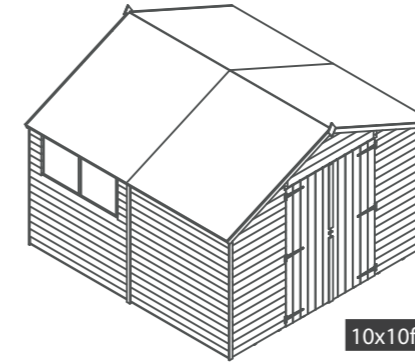

10x10ft - 1 FIXED WINDOW

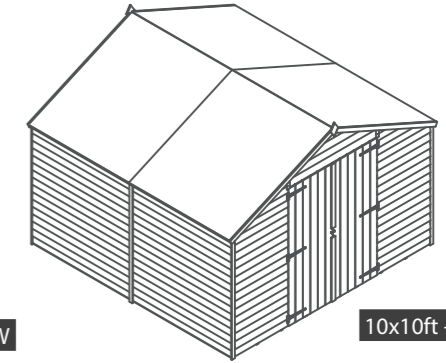

10x10ft - NO WINDOWS

## 15X10 Apex

**Overall Dimensions:**  
Width = 3097mm  
Depth = 4528mm  
Height = 2255mm

**Base Dimensions:**  
Width = 2974mm  
Depth = 4461mm

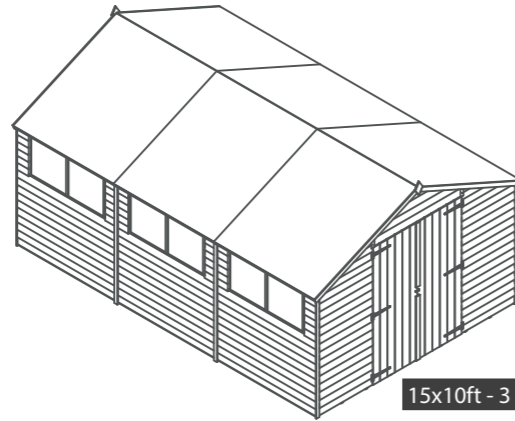

15x10ft - 3 FIXED WINDOWS

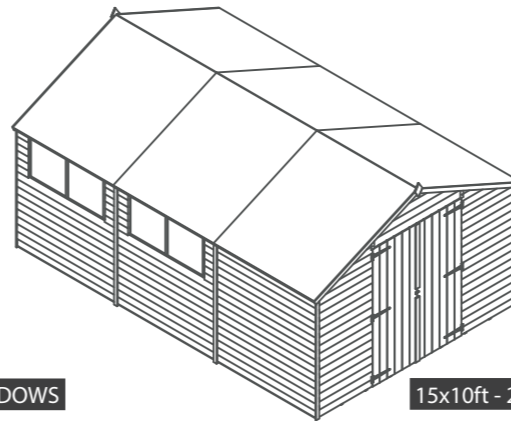

15x10ft - 2 FIXED WINDOWS

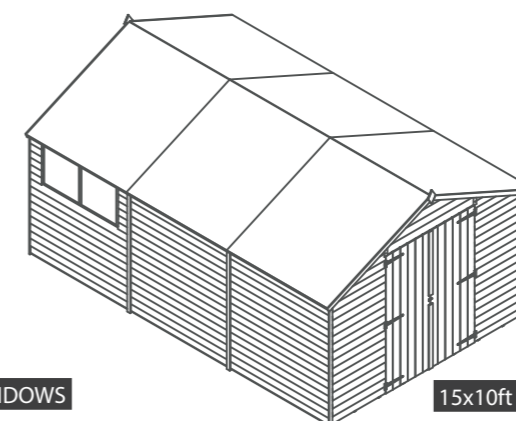

15x10ft - 1 FIXED WINDOW

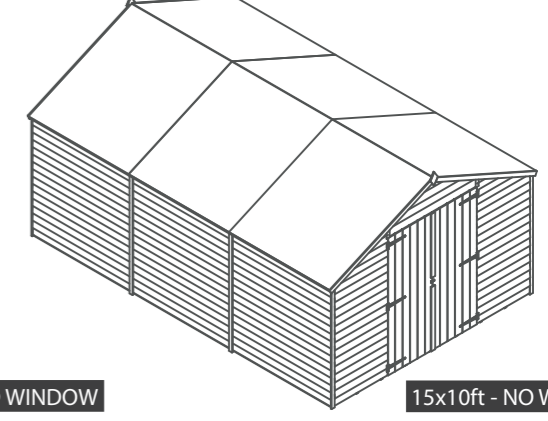

15x10ft - NO WINDOWS

## 20X10 Apex

**Overall Dimensions:**  
Width = 3097mm  
Depth = 6018mm  
Height = 2255mm

**Base Dimensions:**  
Width = 2974mm  
Depth = 5948mm

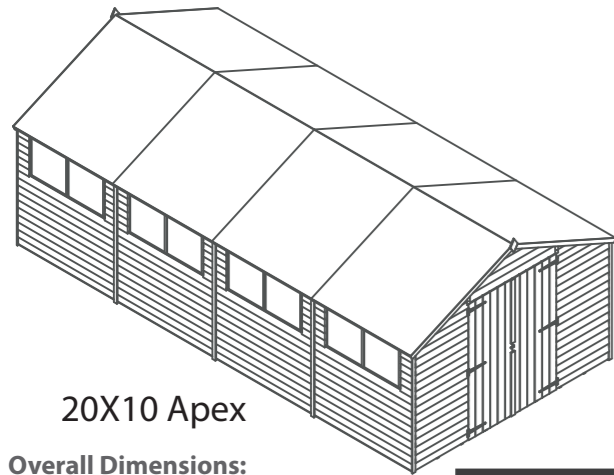

20x10ft - 4 FIXED WINDOWS

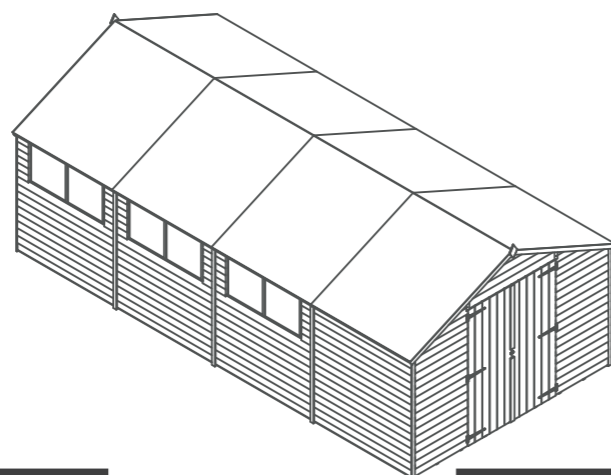

20x10ft - 3 FIXED WINDOWS

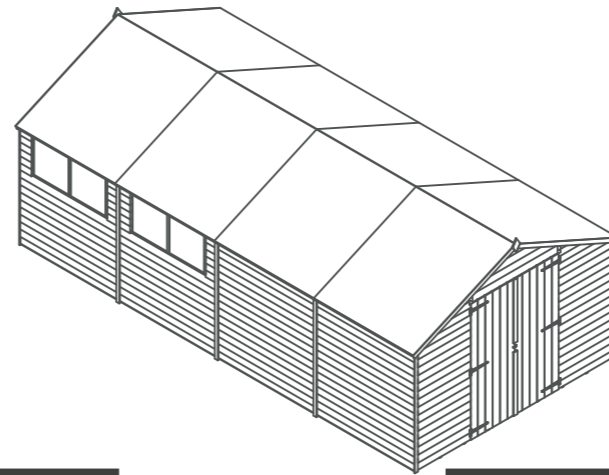

20x10ft - 2 FIXED WINDOWS

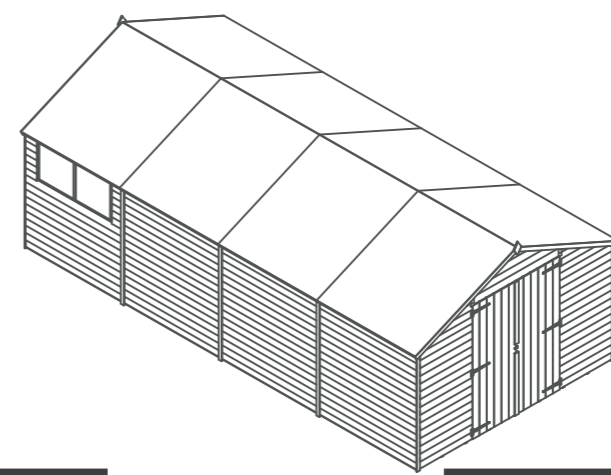

20x10ft - 1 FIXED WINDOW

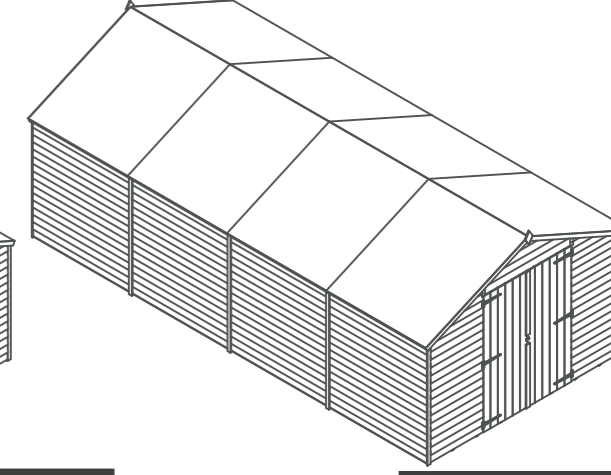

20x10ft - NO WINDOWS

# OVERLAP APEX SHED 10X10

Please retain product label and instructions for future reference

## Building Content - Pack A

01OVLPA10DDGP-V1

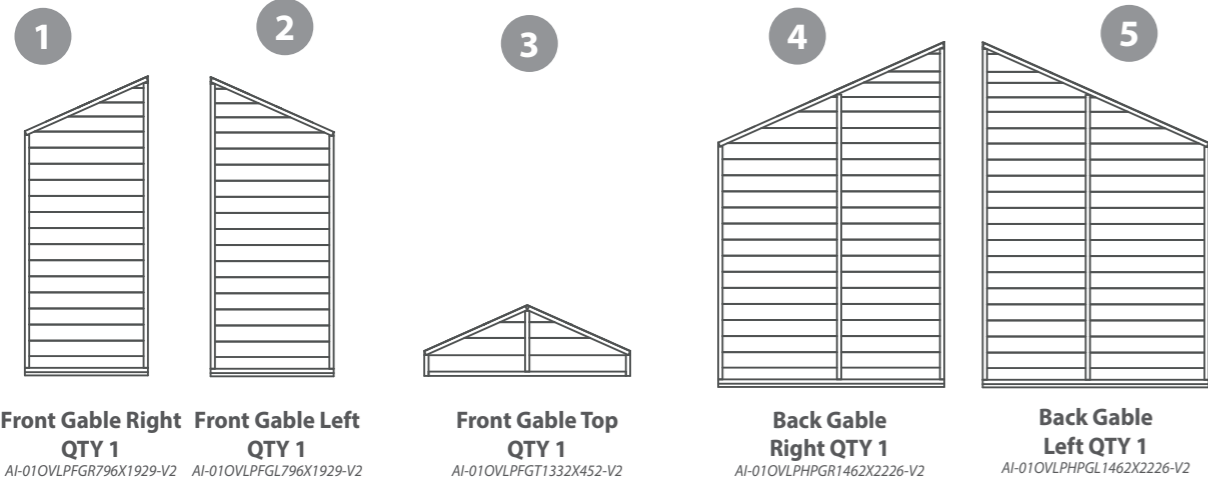

- 6 **Ridge Bar - 27x70x1434mm QTY 1**  
F2770-1434
- 7 **Door Gable Bottom Rail - 28x28x1332mm QTY 1**  
F2828-1332mm
- 8 **Door Strip - 12x56x1000mm QTY 2**  
S1256-1000
- 9 **Cover Trim - 12x45x1585mm QTY 4**  
S1245-1585
- 10 **Door Beading Strip - 12x27x2000mm QTY 2**  
S1227-2000
- 11 **Fascia - 12x56x2000mm QTY 4**  
S1256-2000
- 12 **Door Gable Strip - 7x125x1876mm QTY 1**  
OP7125-1876mm
- 13 **Door Block - 28x28x140mm QTY 2**  
F2828-140
- 14 **Plain Gable Strip - 12x45x1000mm QTY 1**  
S1245-1000
- 15 **Plain Gable Strip - 12x45x2200mm QTY 1**  
S1245-2200

- 16 **Door QTY 2**  
AI-01MBDR1780X661-V1
- 17 **T Hinge QTY 6**  
PI-02-1045
- 18 **Finial QTY 2**  
DIAMOND SHED FINIAL
- 19 **Turn Button QTY 3**  
PI-07-0034
- 20 **L-Bracket QTY 2**  
PI-07-0012
- 21 **Felt**

## Building Content - Pack B Fixed Window

01OVLPA0510FWPB-V1

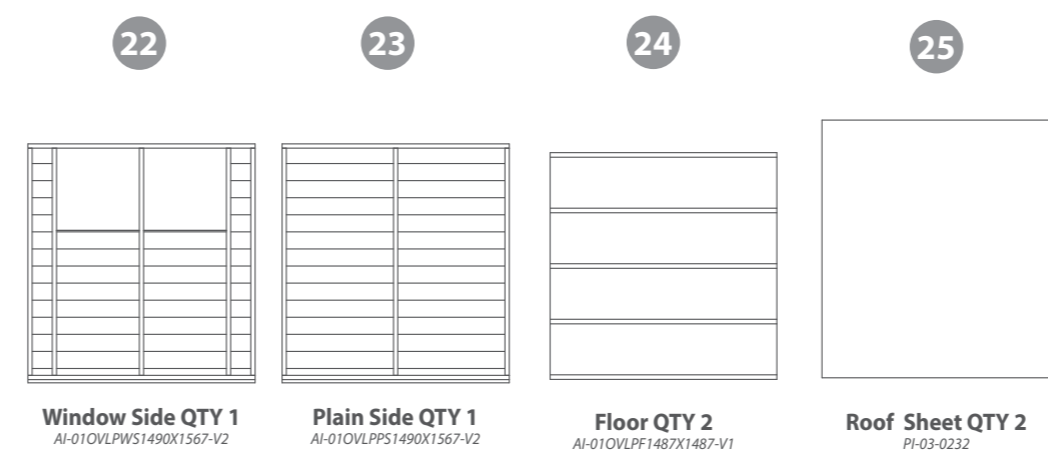

- 26 **Truss QTY 1**  
AI-01TRS2924X690-V2
- 27 **Eaves Frame - 28x28x1502mm QTY 2**  
F2828-1502
- 9 **Cover Trim - 12x45x1585mm QTY 2**  
S1245-1585
- 28 **Ridge Bar - 27x70x1490mm QTY 1**  
F2770-1490
- 29 **Floor Blocks - 28x28x400mm QTY 8**  
F2828-400mm
- 30 **Truss Block - 27x44x140mm QTY 2**  
F2744-G-160 (1X66° cut, 140mm finished length)
- 31 **U Channel QTY 1**  
PI-07-0013
- 32 **Window Strip - 12x27x2000mm QTY 2**  
S1227-2000
- 33 **Styrene QTY 2**  
PI-05-0114
- 34 **Plastic Window Cill QTY 1**  
PI-08-0013

## Building Content - Pack C No Window

01OVLPA0510NWPC-V1

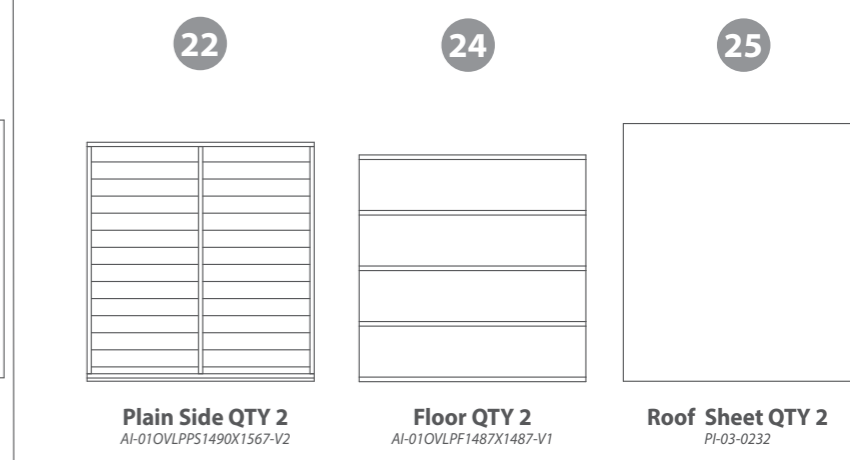

- 26 **Truss QTY 1**  
AI-01TRS2924X690-V2
- 27 **Eaves Frame - 28x28x1502mm QTY 2**  
F2828-1502
- 9 **Cover Trim - 12x45x1585mm QTY 2**  
S1245-1585mm
- 28 **Ridge Bar - 27x70x1490mm QTY 1**  
F2770-1490
- 29 **Floor Blocks - 28x28x400mm QTY 8**  
F2828-400
- 30 **Truss Block - 27x44x140mm QTY 2**  
F2744-G-160 (1X66° cut, 140mm finished length)
- 31 **U Channel QTY 1**  
PI-07-0013

### Nail Bag

There may be extra screws present in the nail bag

- 30mm Screw x 75
- 40mm Screw x 41
- 50mm Screw x 39

### Nail Bag

There may be extra screws present in the nail bag

- Felt Tacks x 100
- 30mm Screw x 33
- 40mm Screw x 54
- 50mm Screw x 14
- 70mm Screw x 6
- 100mm Screw x 2

### Nail Bag

There may be extra screws present in the nail bag

- Felt Tacks x 100
- 30mm Screw x 18
- 40mm Screw x 54
- 50mm Screw x 14
- 70mm Screw x 6
- 100mm Screw x 2



### Pre Assembly

Remove transportation blocks from the bottom of each panel before beginning assembly. Each Panel should have two blocks.

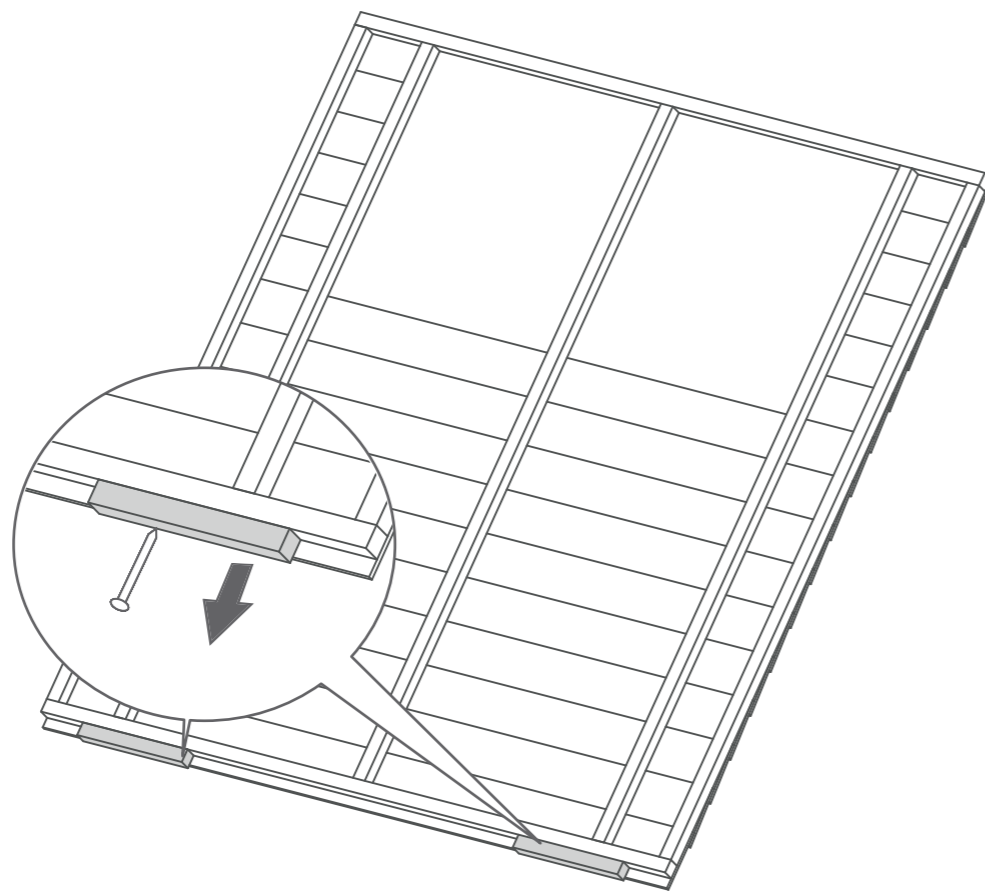

### Step 2

Parts Needed - No. 2 QTY 1

Lay the Front Gable Left (No. 2) next to the Front Top Gable, ensure they are level at the top then fix together using 2x50mm screws. Stagger the screws so they do not collide.

2 x 50mm screws

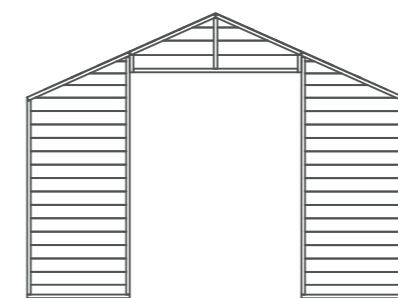
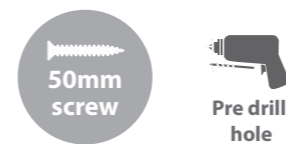

IMPORTANT: Pre-drill before fixing screws.

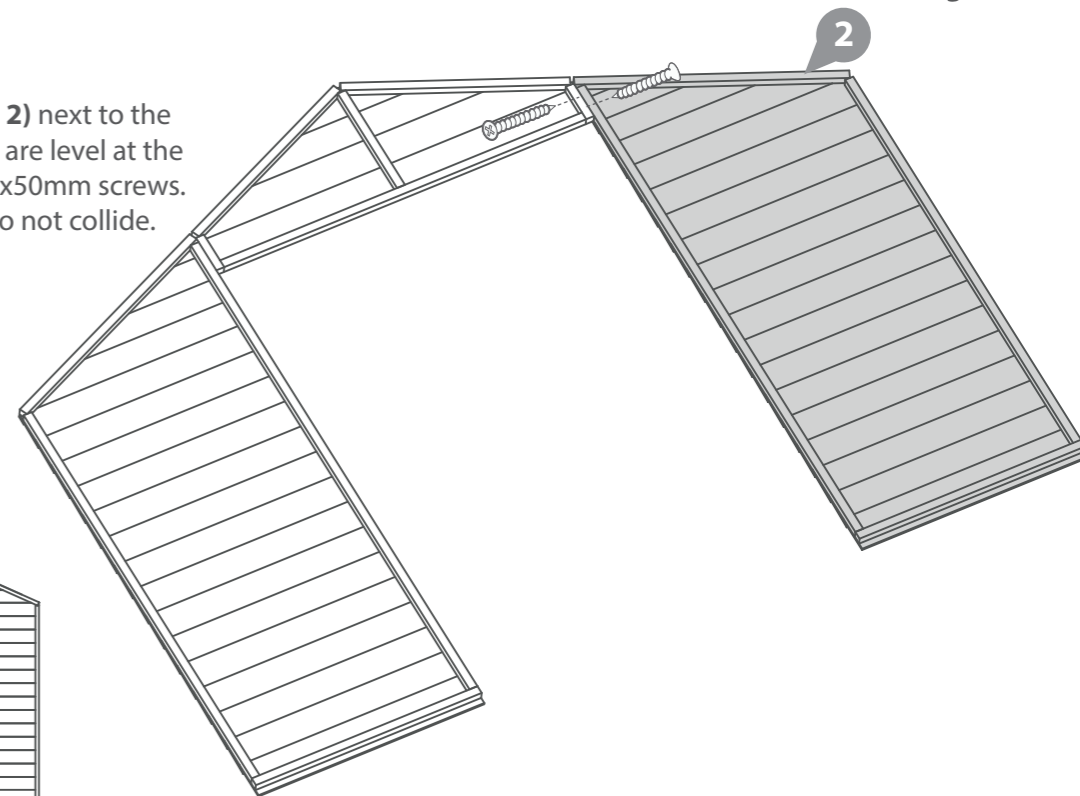

### Step 1 Door Gable Assembly

Parts Needed - No. 1 QTY 1  
No. 3 QTY 1

Lay the Front Gable Right (No 1) and Front Gable top (No 3) on a level floor place them next to each other, ensure they are level at the top then fix together using 2x50mm screws. Stagger the screws so they do not collide.

2 x 50mm screws



IMPORTANT: Pre-drill before fixing screws.

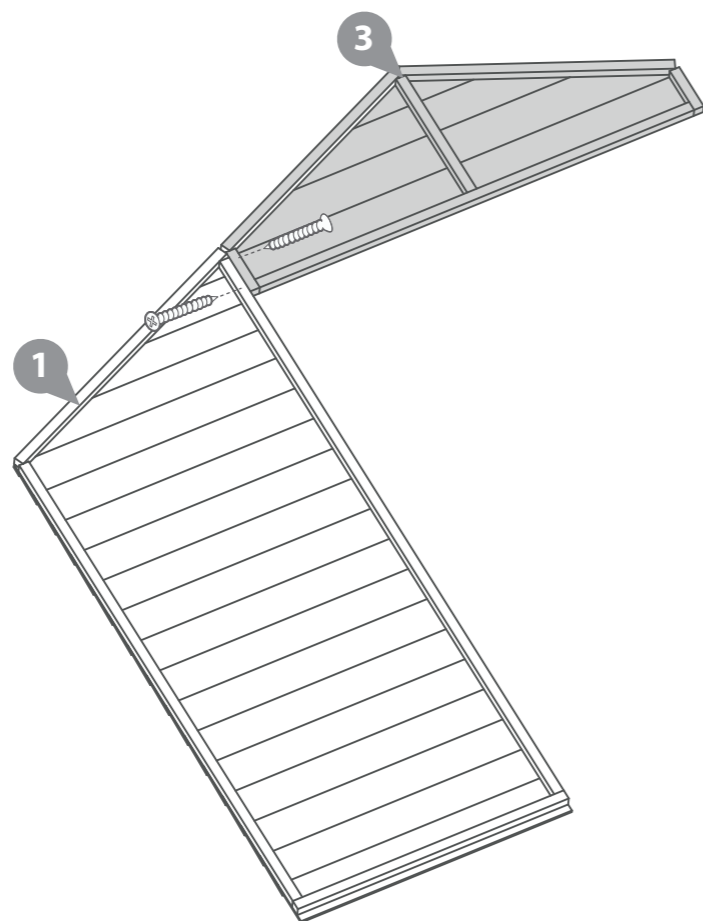

### Step 3

Parts Needed - No. 12 QTY 1

Line the Door Gable Strip up (No. 12) to the assembled gable at the corners as shown in the illustration and fix in place using 40mm screws

6 x 40mm screws

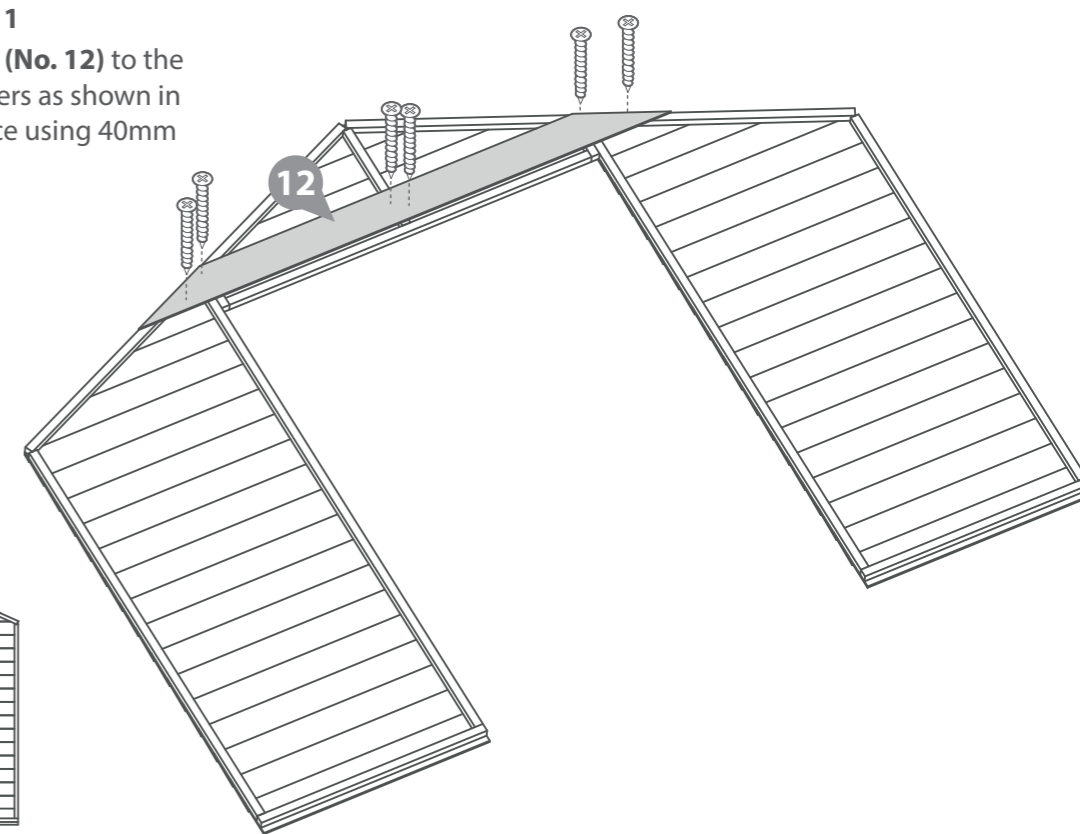
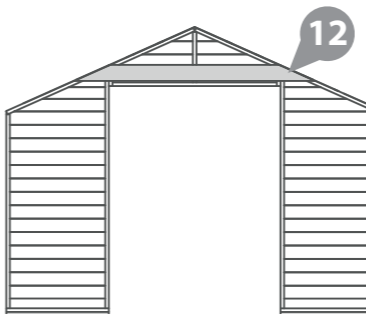
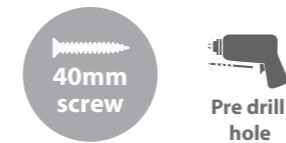

## Step 4 Plain Gable Assembly

Parts Needed - No. 4 QTY 1  
No. 5 QTY 1

Lay the Back Left Gable and Back Right Gable on a level floor place them next to each other, ensure they are level at the top and bottom then fix together using 10x50mm screws. Stagger the screws so they do not collide.

10 x 50mm screws

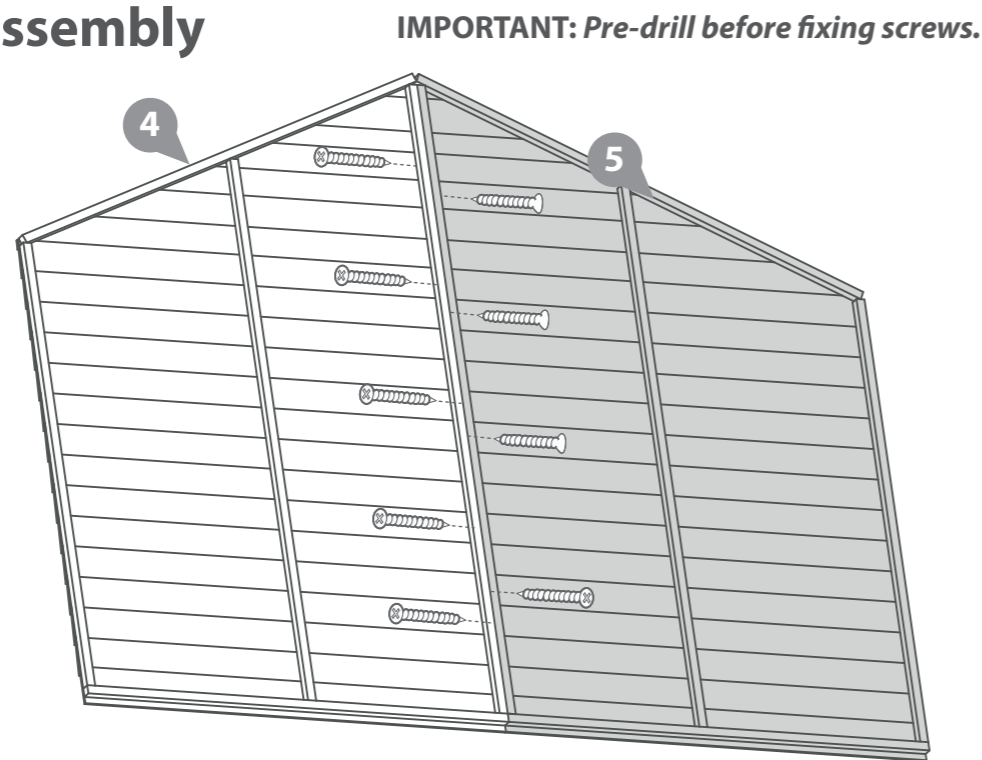
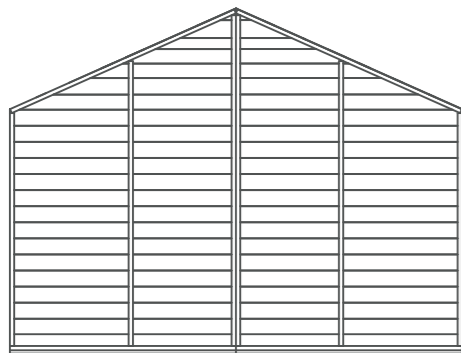
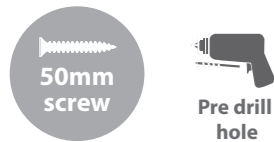

## Step 6

Parts Needed 10x10 - No. 24 QTY 2  
No. 29 QTY 8  
Parts Needed 15x10 - No. 24 QTY 4  
No. 29 QTY 16  
Parts Needed 20x10 - No. 24 QTY 6  
No. 29 QTY 24

Fix another two floor panels (No. 24) using the floor blocks (No. 29) provided.

Place the floor blocks in between the framing as shown in the diagram.

Screw the floor blocks to floor using 2x40mm screws per block screwing through the floor into the floor blocks.

Fix the two floor panels together using the same method shown in step 4 using 8x40mm screws.

Repeat this step once more if you are assembling the 15x10 and another two times if you are assembling the 20x10.

10x10 - 24x40mm screws  
15x10 - 48x40mm screws  
20x10 - 72x40mm screws

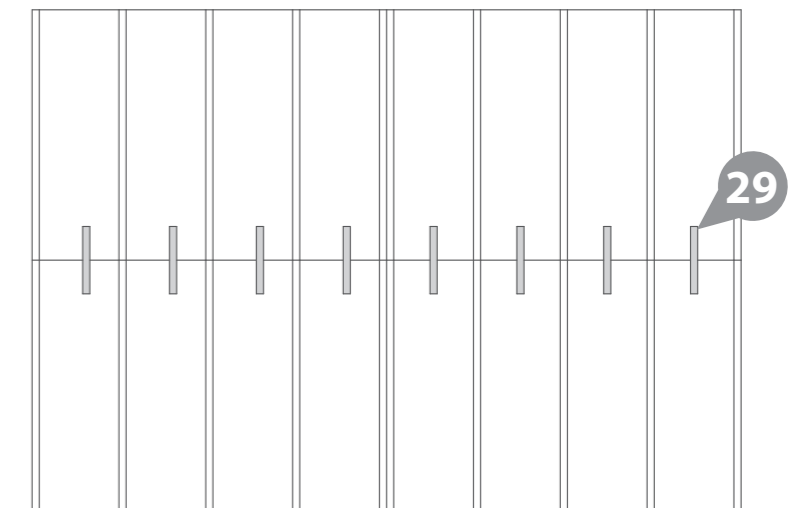
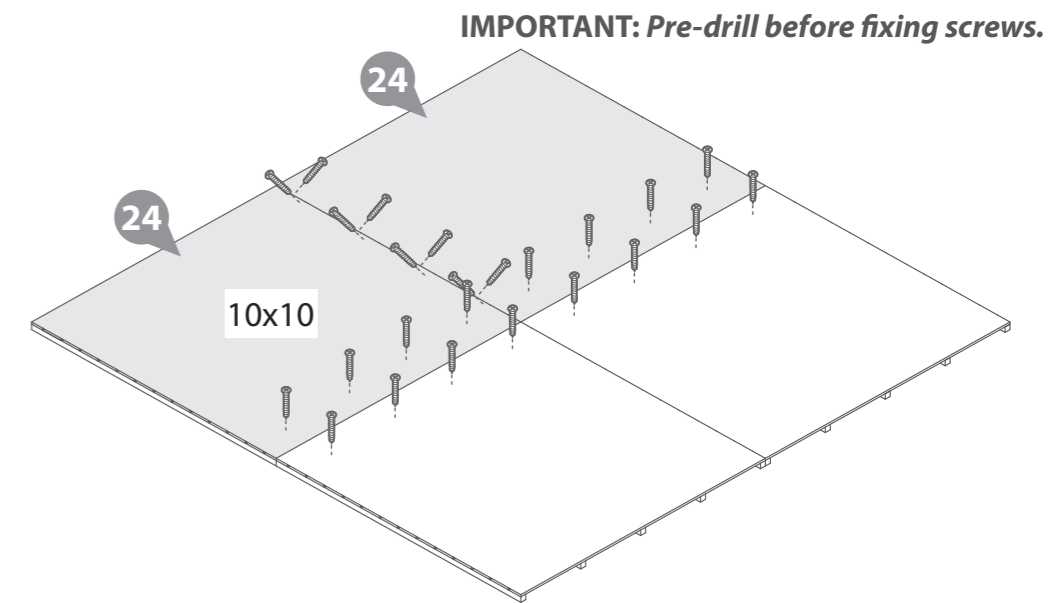
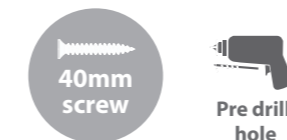

## Step 5

Parts Needed - No. 24 QTY 2

Place floor (No. 24) on firm and level base, ensure base has suitable drainage free from areas where water can collect. (See front page on base requirements).

If you are building a 5x10 shed, please proceed to Step 7:

Attach the floors using 8 x 40mm screws

8 x 40mm screws

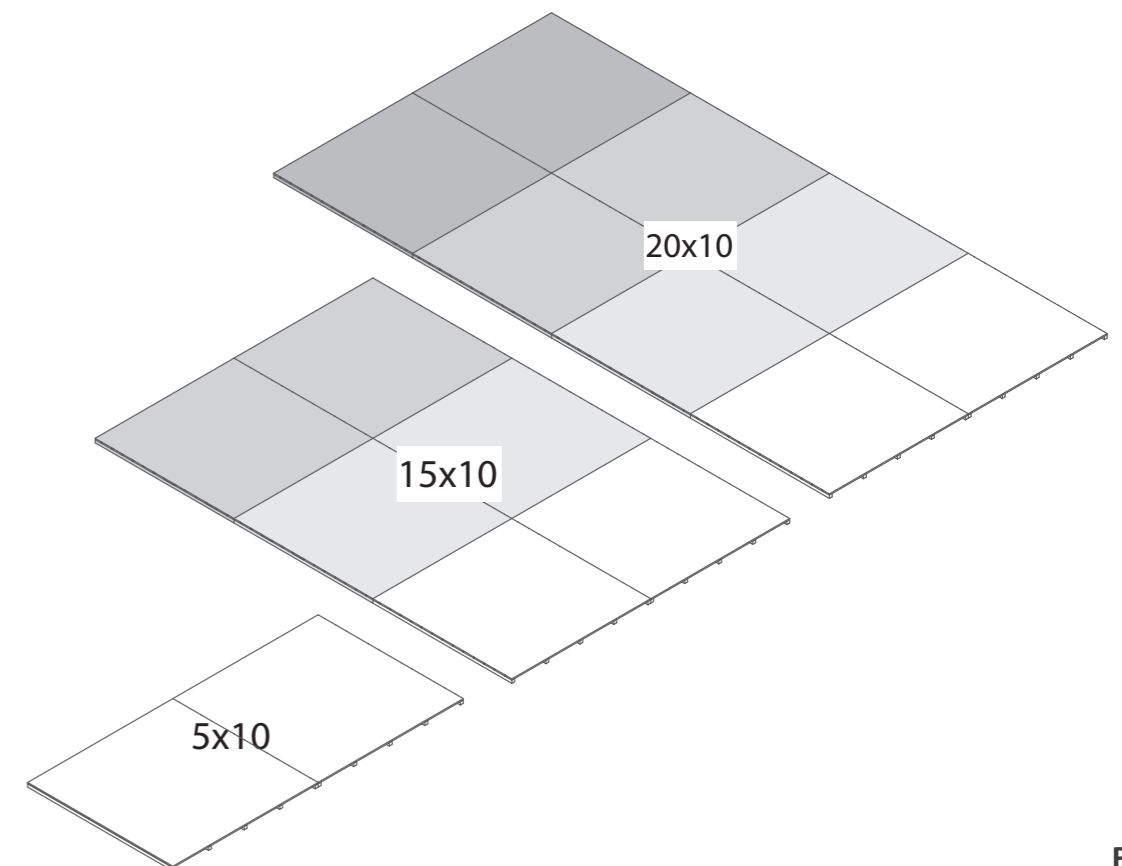
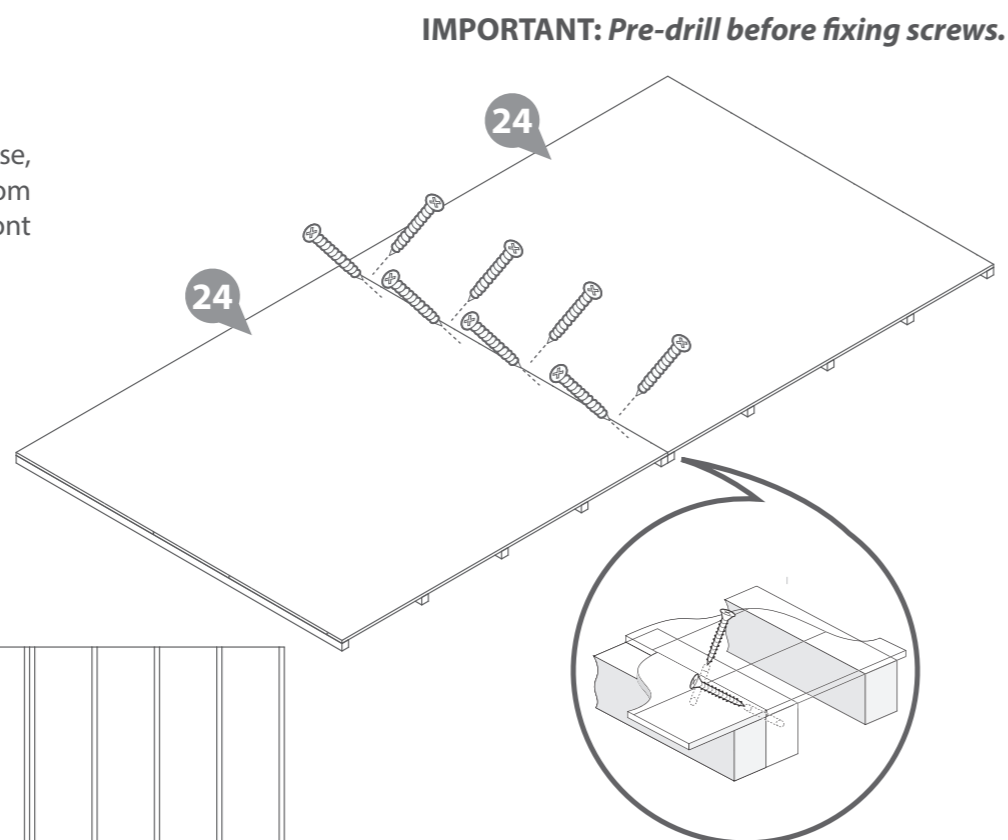
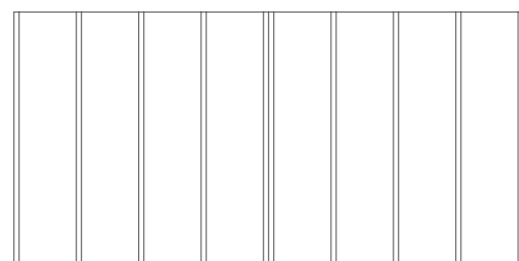
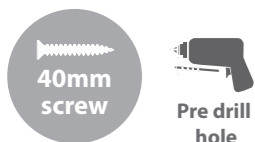

## Step 7

Parts Needed - No. 23 QTY 1

Place the assembled Back Gable Panel (please refer to Step 3 if you have not yet assembled this) and the Plain Panel (No. 23) next to each other and onto the floor as shown in the illustration,

Ensure to position the panels so there is equal spacing between the floor and cladding on each side.

Fix the two Panels together by screwing into the corner using 50mm screws.

3x50mm Screws

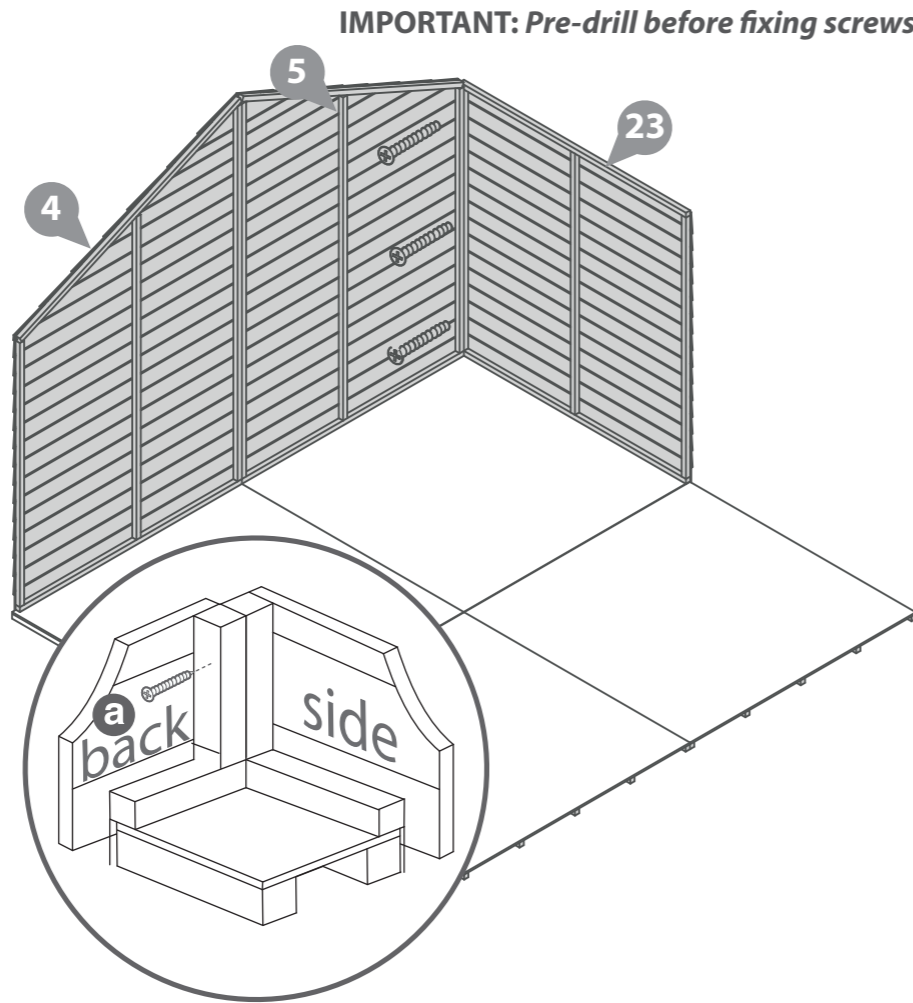
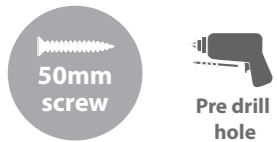

## Step 9

Parts Needed 10x10 - No. 23 QTY 1 (No Window QTY2)  
No. 22 QTY 1 (Fixed Window ONLY)  
Parts Needed 15x10 - No. 23 QTY 2 (No Window QTY4)  
No. 22 QTY 2 (Fixed Window ONLY)  
Parts Needed 20x10 - No. 23 QTY 3 (No Window QTY6)  
No. 22 QTY 3 (Fixed Window ONLY)

Using the same method continue to fix either Window Panels (No. 22) or other Plain Panels (No. 23) on to your shed. Fix at the corners using 50mm screws as shown in the diagram.

Ensure to position the panel so there is equal spacing between the floor and cladding on each side.

Do not secure the building to the floor until the roof is fitted.

10x10 - 6x50mm Screws  
15x10 - 12x50mm Screws  
20x10 - 18x50mm Screws

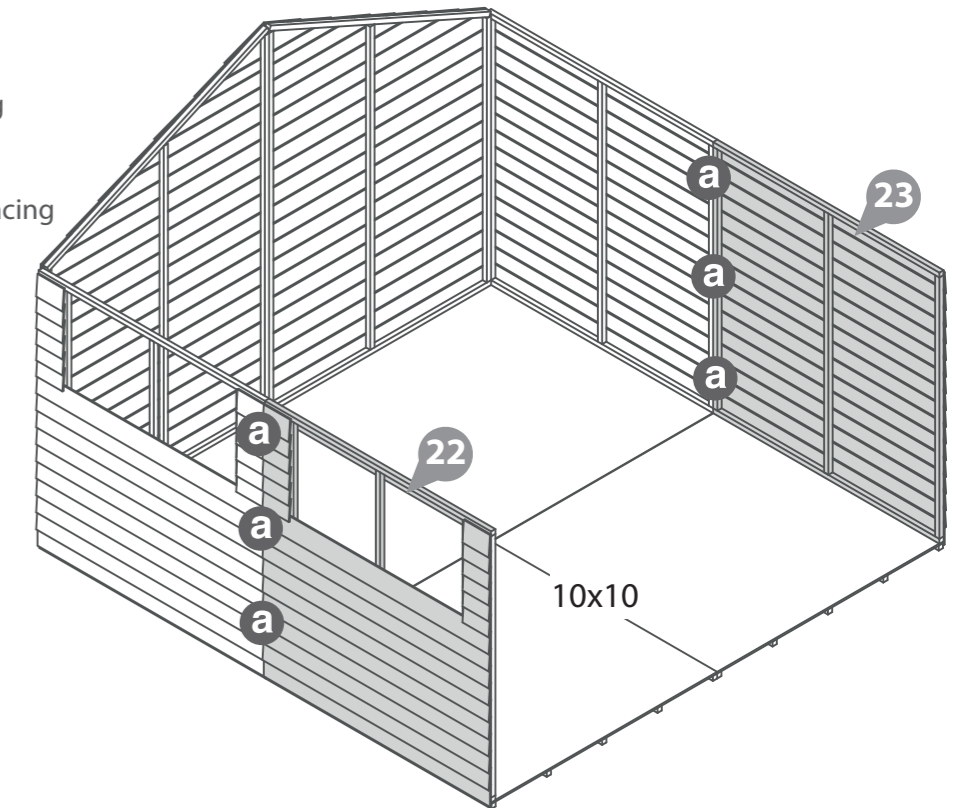
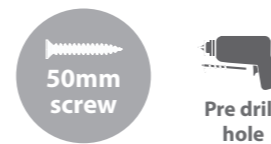

## Step 8

Parts Needed - No. 23 QTY 1 (No Window ONLY)  
No. 22 QTY 1 (Fixed Window ONLY)

On the opposite side of the shed, repeat the method used in Step 7 to fix either a Window Panel (No. 22) or another Plain Panel (No. 23) on to your Shed.

Ensure to position the panels so there is equal spacing between the floor and cladding on each side.

If you are building a 5x10 shed, please proceed to Step 10:

3x50mm Screws

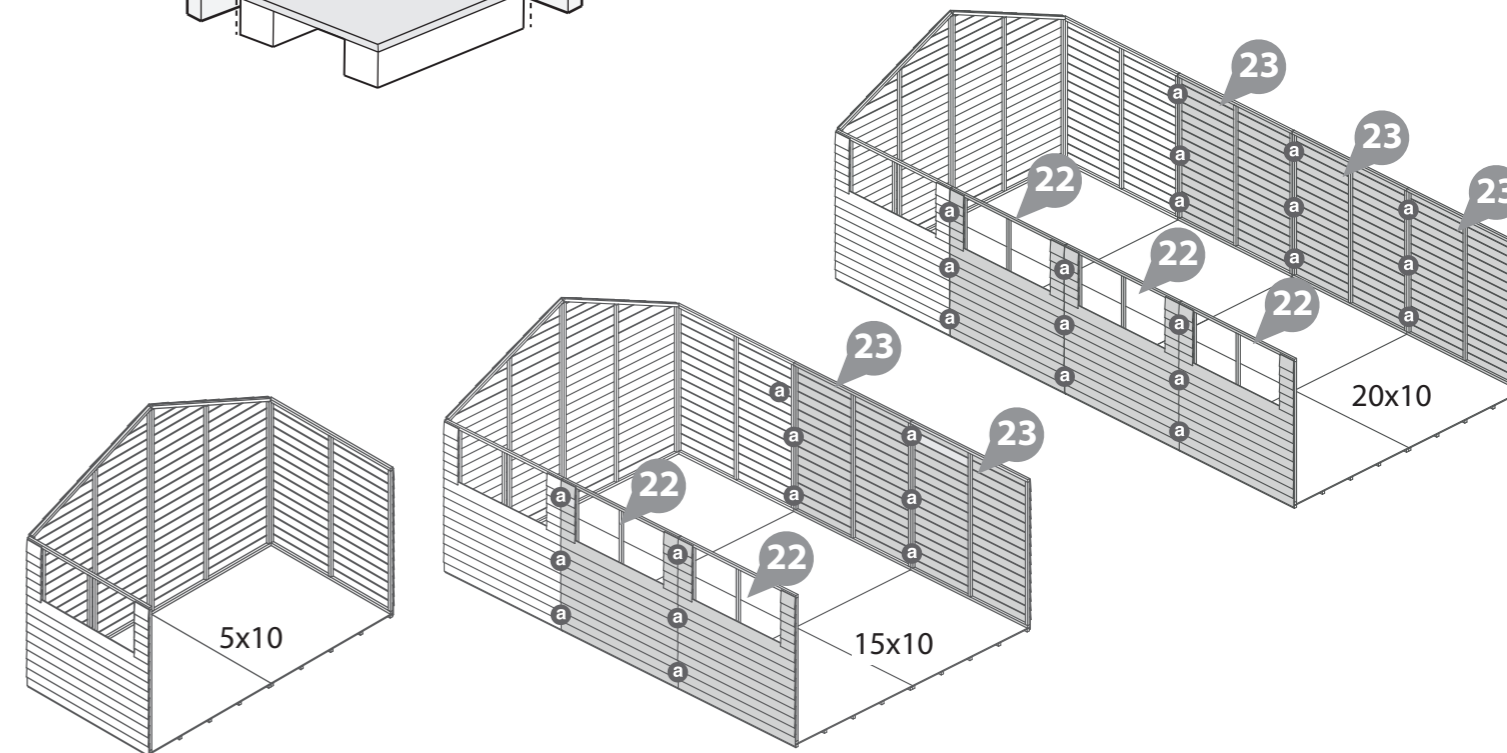
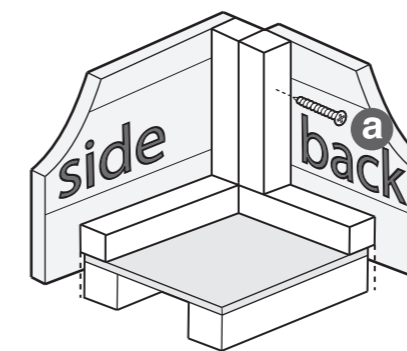
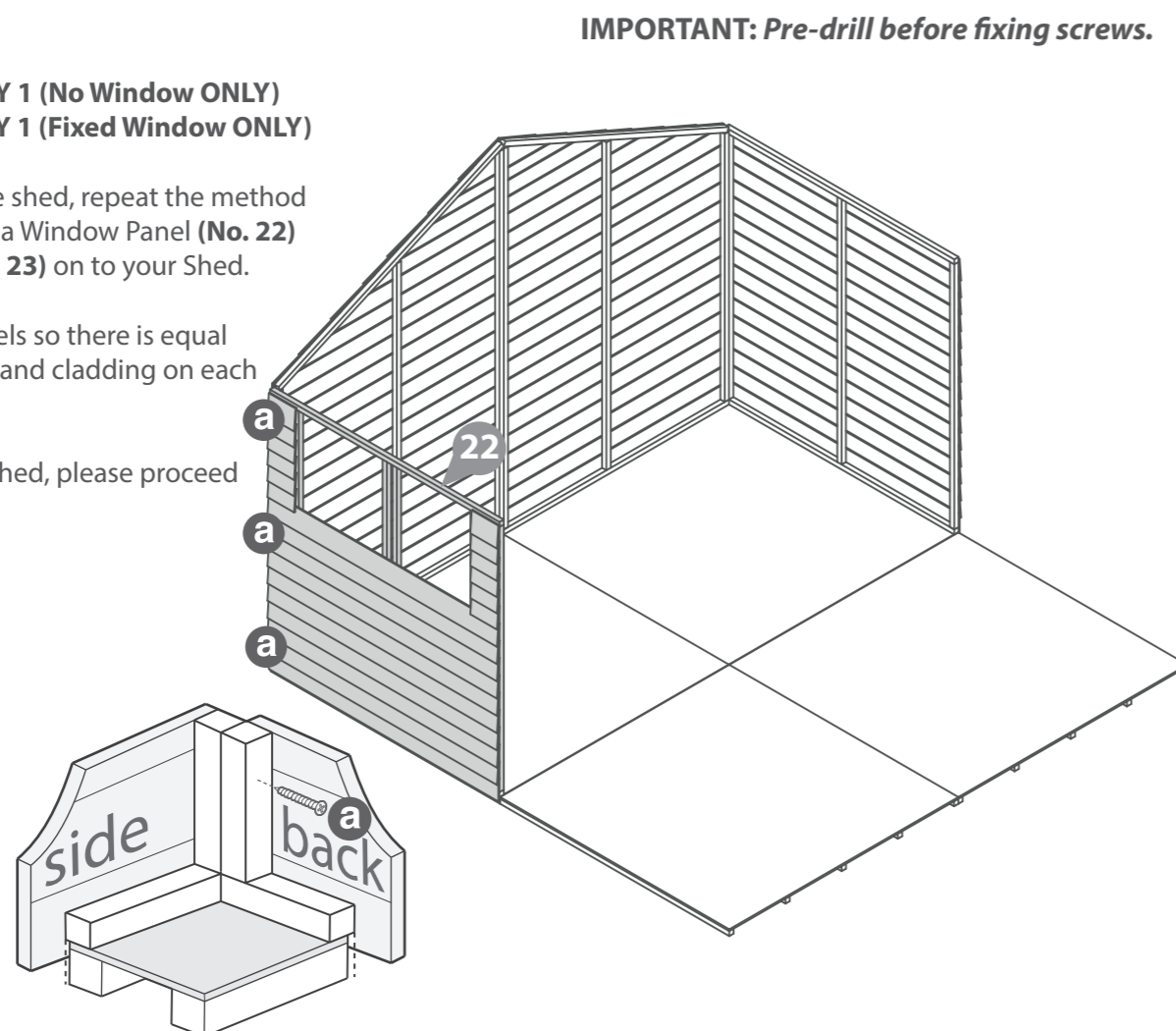



## Step 10

Fix the Door Gable (refer to steps 1 and 2 if you have not already assembled this) at the corners with 50mm screws as shown in diagram.

**6x50mm Screws**

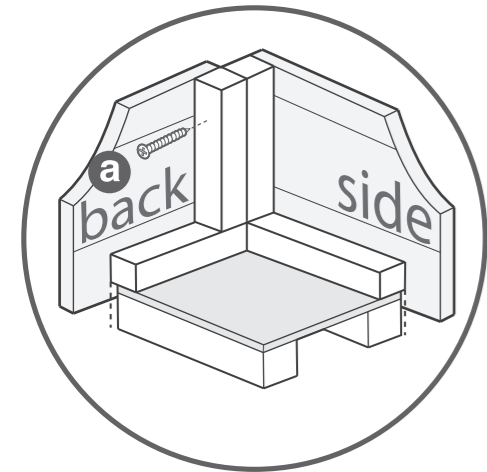
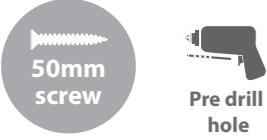

**IMPORTANT: Pre-drill before fixing screws.**

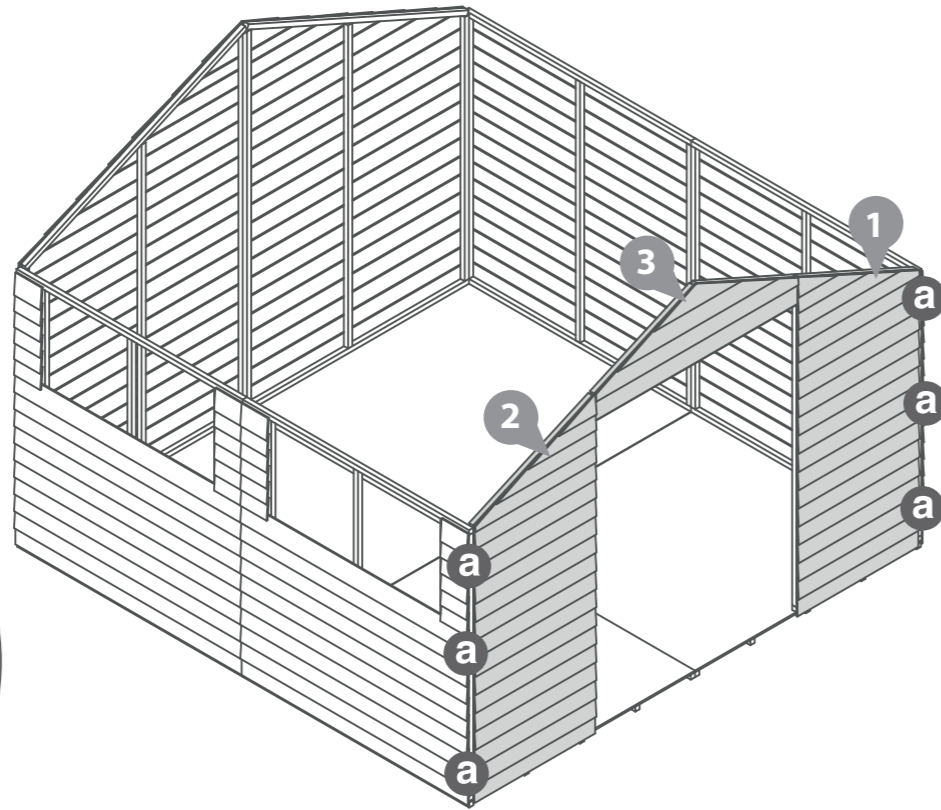

## Step 12

**Parts Needed - No. 17 QTY 6  
No. 16 QTY 2**

Fix the T Hinges (**No. 17**) on to the doors (**No. 16**) and door gable as shown. Ensure that the screws go through the cladding and into the framing behind.

**If you are building a 5x10 shed, please proceed to Step 14.**

**42x30mm screws**

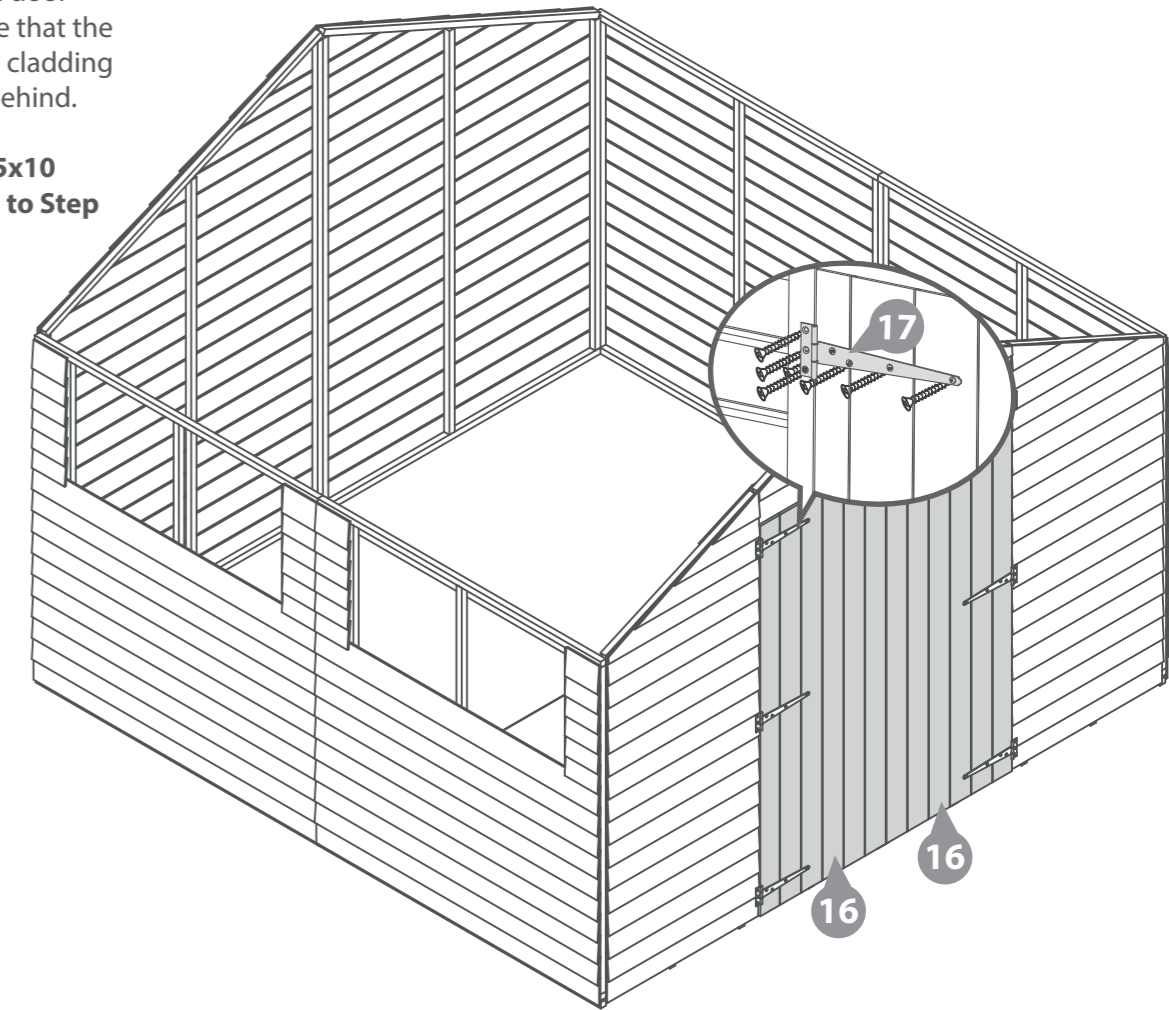
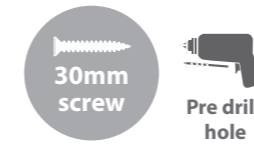

## Step 11

**Parts Needed - No. 7 QTY 1**

Fit the Door Gable Bottom rail (**No. 7**) between the Front Gable Left and Right. Fix to the floor using 3x50mm screws making sure the screws go through to the floor framing.

**3x50mm Screws**

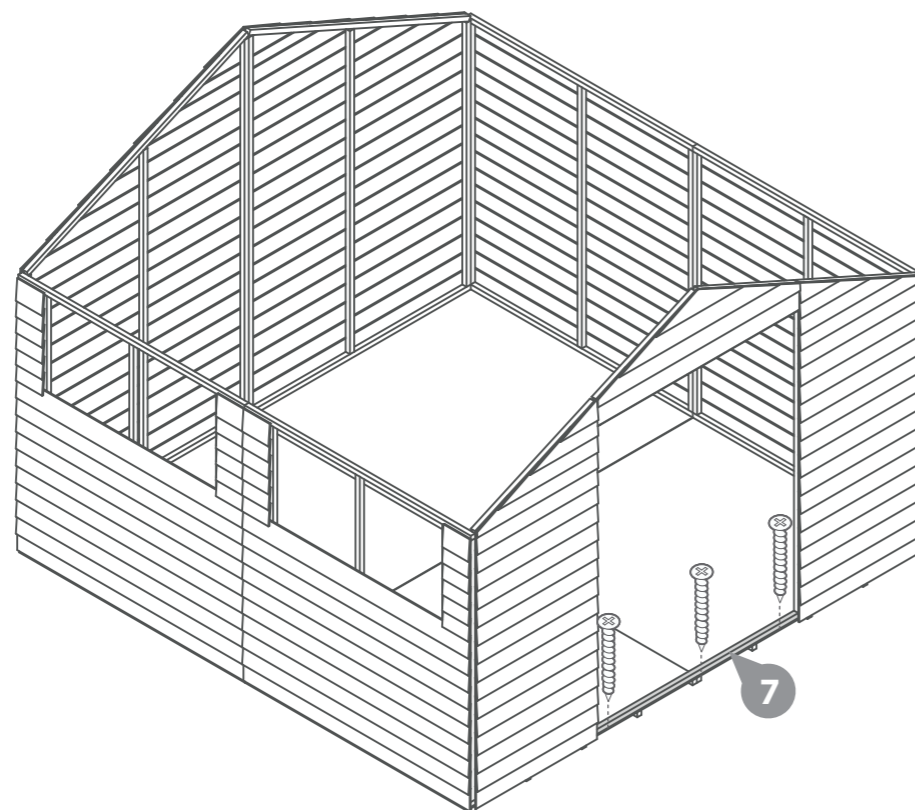

**IMPORTANT: Pre-drill before fixing screws.**

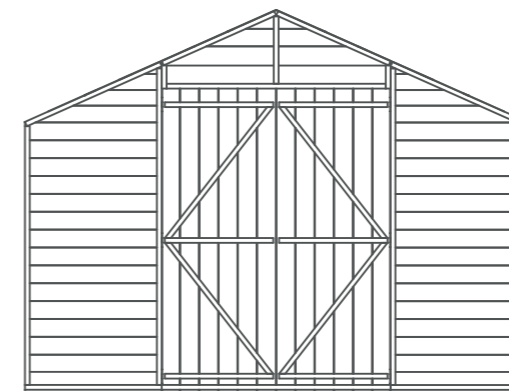

Internal View

# Step 13

- Parts Needed -**  
 10x10 - No. 26 QTY 1  
           No. 30 QTY 2  
 15x10 - No. 26 QTY 2  
           No. 30 QTY 4  
 20x10 - No. 26 QTY 3  
           No. 30 QTY 6

Place a Truss central to where two panels join. Align the top of the truss with the top of the sides as shown in the diagram.  
 HINT - Use a piece from the fixing kit as a guide.  
 Pencil mark the truss position and remove truss.  
 Place the truss blocks up to the pencil mark and fix using 2x70mm screws per block.  
 Place the truss back into position on top of the support block and secure using 100mm screw each side from the top down through the truss and into the block.

For 15x10 and 20x10 build a truss where each panel joins, for 5x10 you will have no trusses, 10x10 you will have one truss, 15x10 you will have two trusses and for the 20x10 you will have three trusses.

- 5x10 - No Truss**  
**10x10 - 4x70mm Screws**  
           2x100mm Screws  
**15x10 - 8x70mm Screws**  
           4x100mm Screws  
**20x10 - 12x70mm Screws**  
           6x100mm Screws

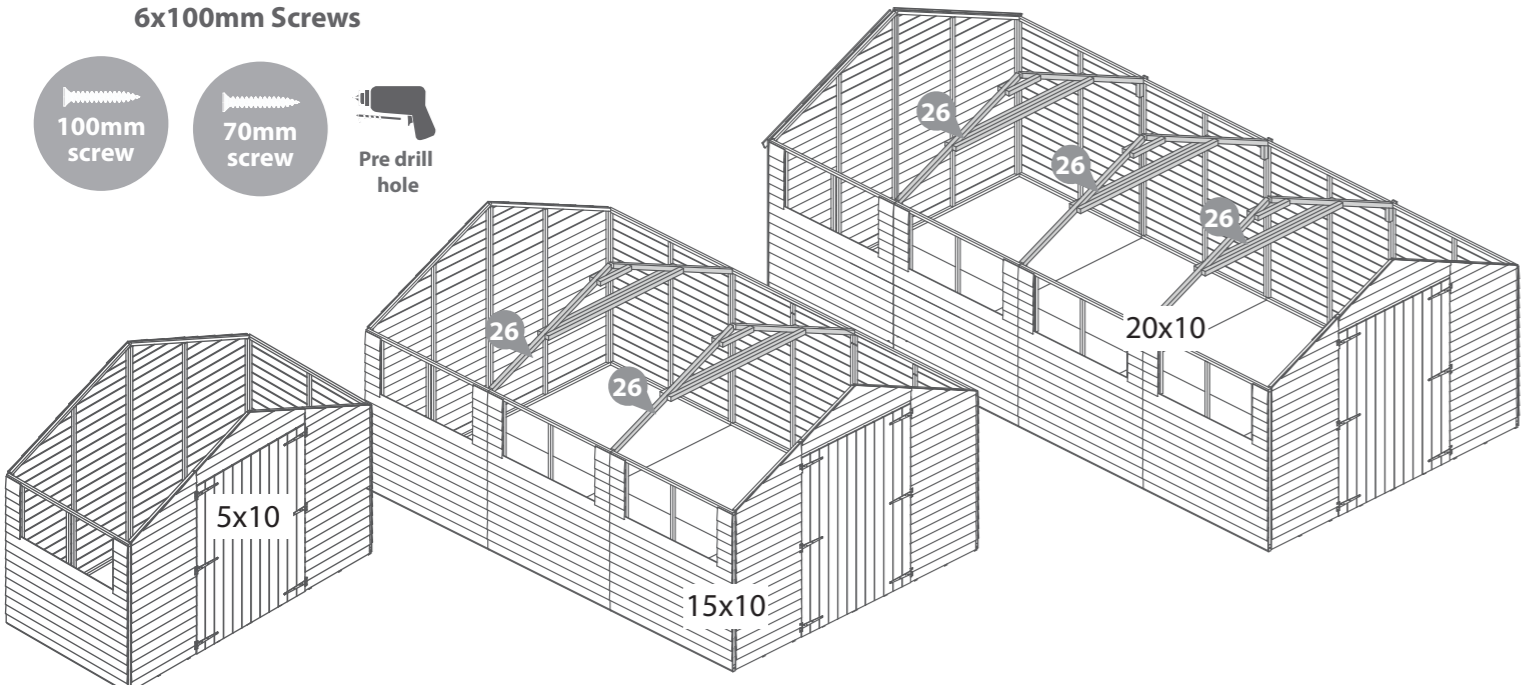
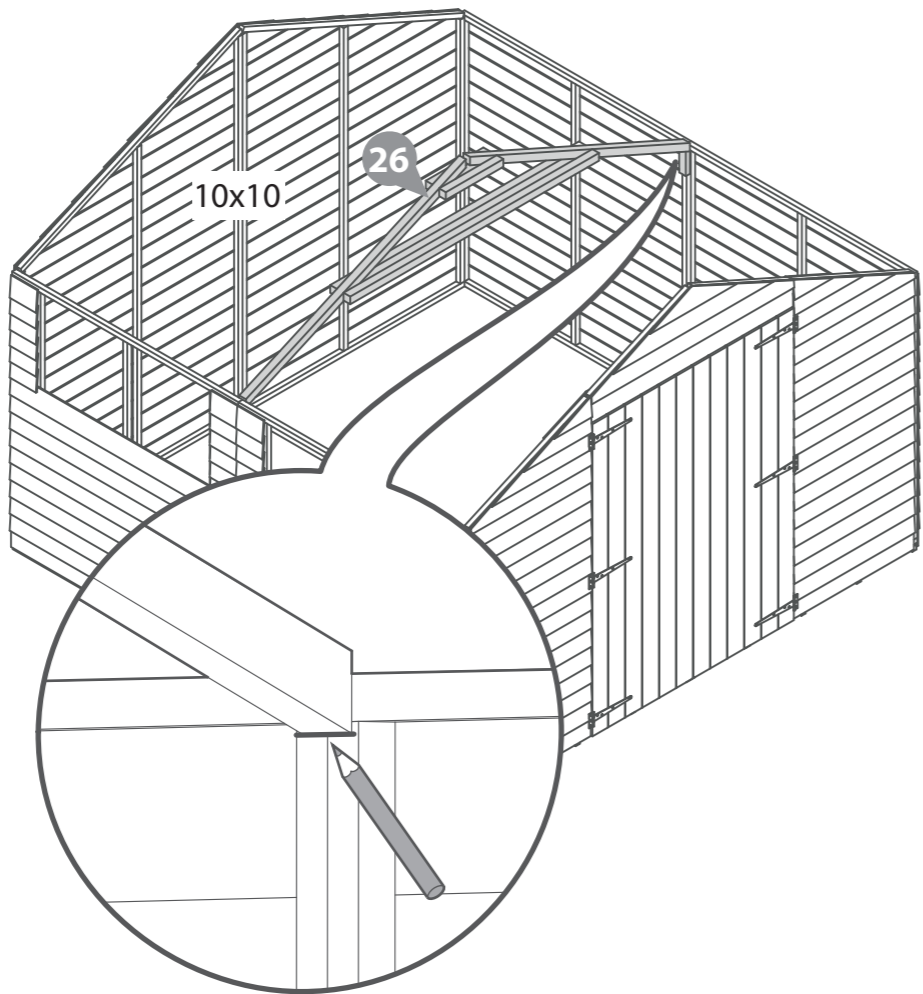
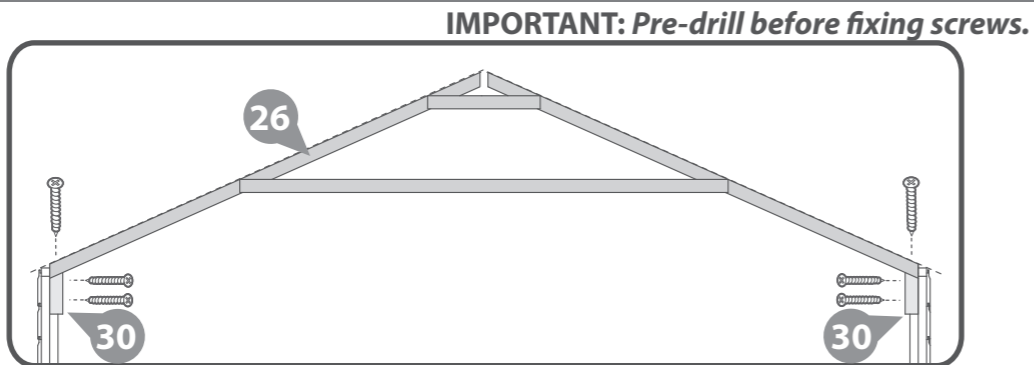
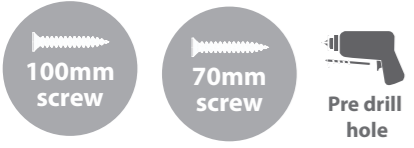

# Step 14

- Parts Needed -**  
 5x10 - No. 6 QTY1, No. 20 QTY 2  
 10x10 - No. 6 QTY 1, No. 20 QTY 2,  
           No. 28 QTY 1, No. 31 QTY 1  
 15x10 - No. 6 QTY 1, No. 20 QTY 2,  
           No. 28 QTY 2, No. 31 QTY 2  
 20x10 - No. 6 QTY 1, No. 20 QTY 2,  
           No. 28 QTY 3, No. 31 QTY 3

For 5x10, you do not need a U-channel. You only need to fit the one ridge bar (No. 6) using the 'L' Brackets.

Position the Ridge Bars (No. 6 & 28) within the 'U' channel (No. 31). Secure from either side with 3x30mm screws and 4x30mm screws from underneath.

For 15x10 you need to add another ridge bar and U-channel. For 20x10 you need to add a further two ridge bars and U-channels.

Secure an 'L' bracket (No. 20) to either end of the ridge bar using 2x30mm screws per bracket.

Place the assembled ridge bar in between the front and back Gables above the already fitted truss. Ensure the top corners of the support bar are flush with each top point of the Gable.

Secure the 'L' brackets (No. 20) on to both the Gables framing using 2x30mm screws.

Using 2x70mm screws, secure the ridge bar to the truss. Screw in from above either side of the truss as shown in the diagram.

**IMPORTANT: Pre-drill before fixing screws.**

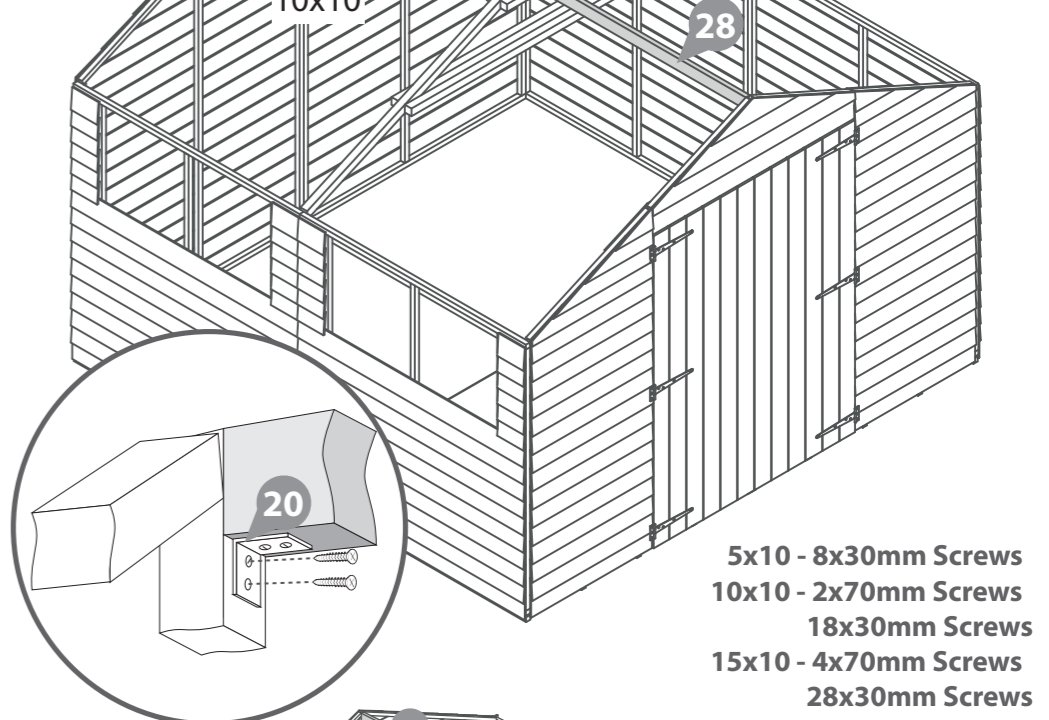
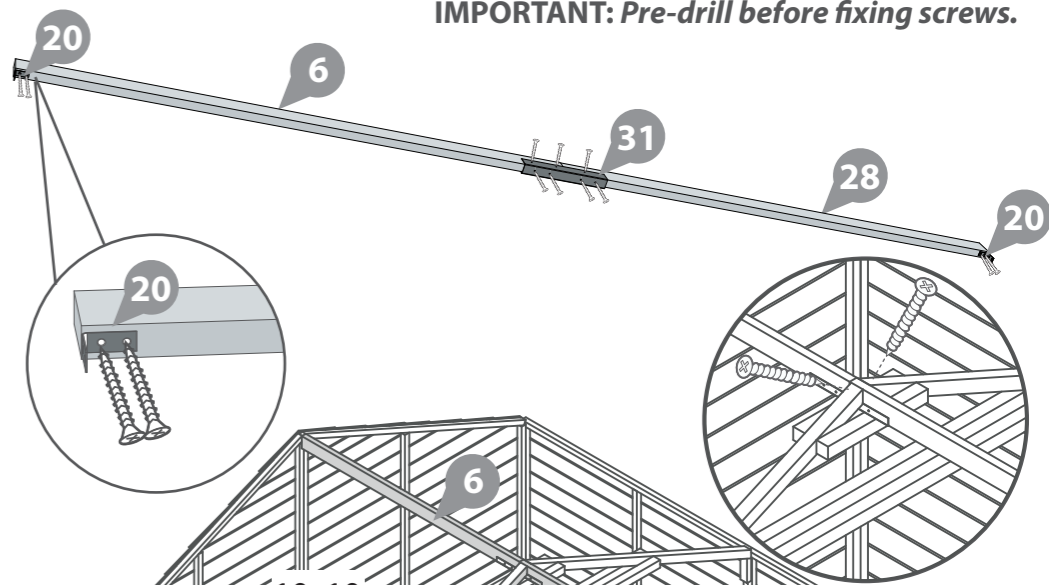

- 5x10 - 8x30mm Screws**  
**10x10 - 2x70mm Screws**  
           18x30mm Screws  
**15x10 - 4x70mm Screws**  
           28x30mm Screws  
**20x10 - 6x70mm Screws**  
           38x30mm Screws

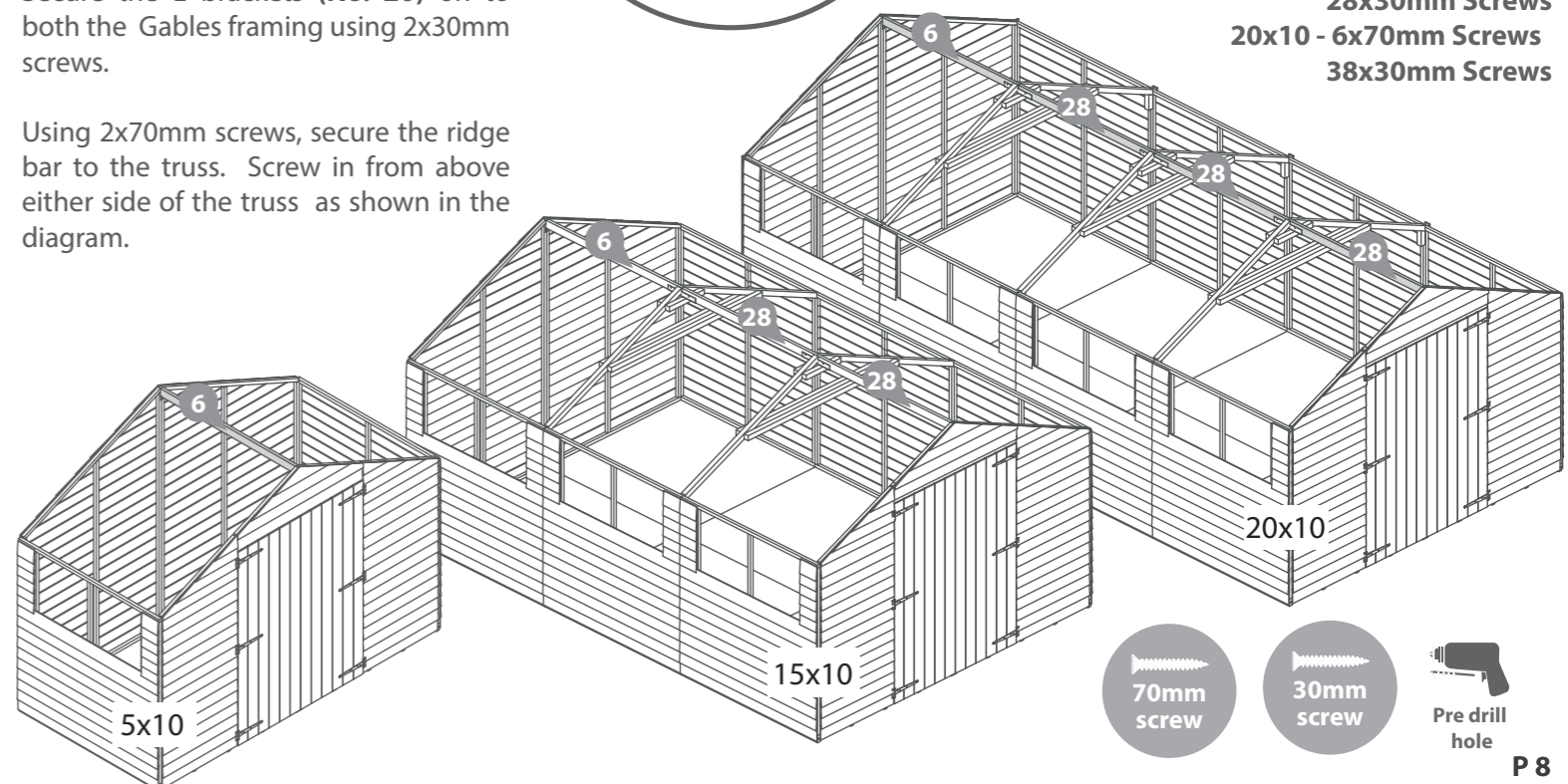



**IMPORTANT: Pre-drill before fixing screws.**

**IMPORTANT: Pre-drill before fixing screws.**

# Step 15

**Parts Needed - No. 27 QTY 2  
No. 25 QTY 2**

Fix the eaves frame (No. 27) to the roof sheet (No. 25) sheet using 4x30mm screws for each sheet.

**If you are constructing a 5x10, go to step 17.**

Place two roof sheets on top of the plain gable and truss making sure the roof sheet sits flush to the outside edge of the plain gable and fix using 40mm screws. Before fixing the roof sheet to the truss frame make sure the edge of the roof sheet sits in the middle of the truss then fix using 40mm screws.

**8x30mm Screws  
24x40mm Screws**

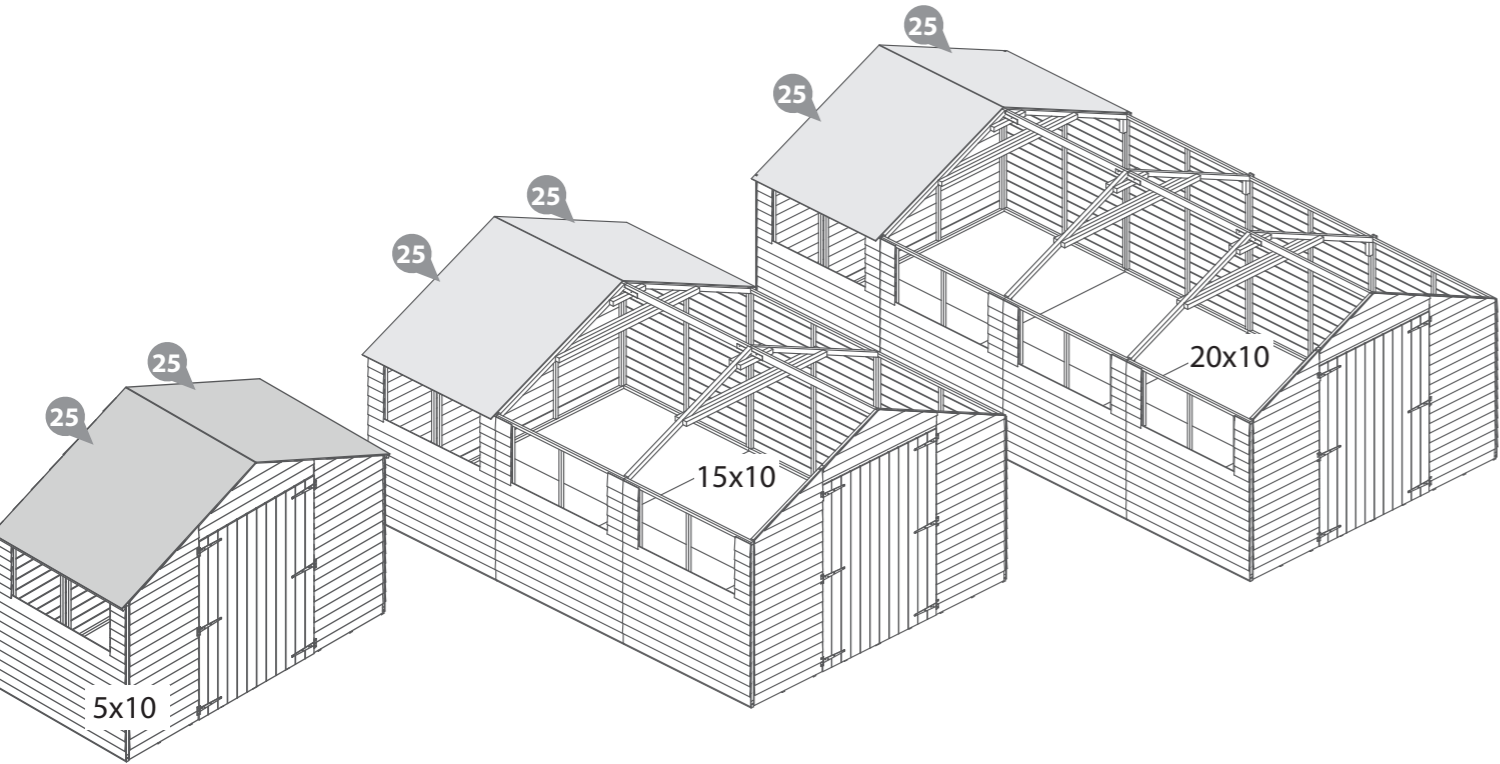
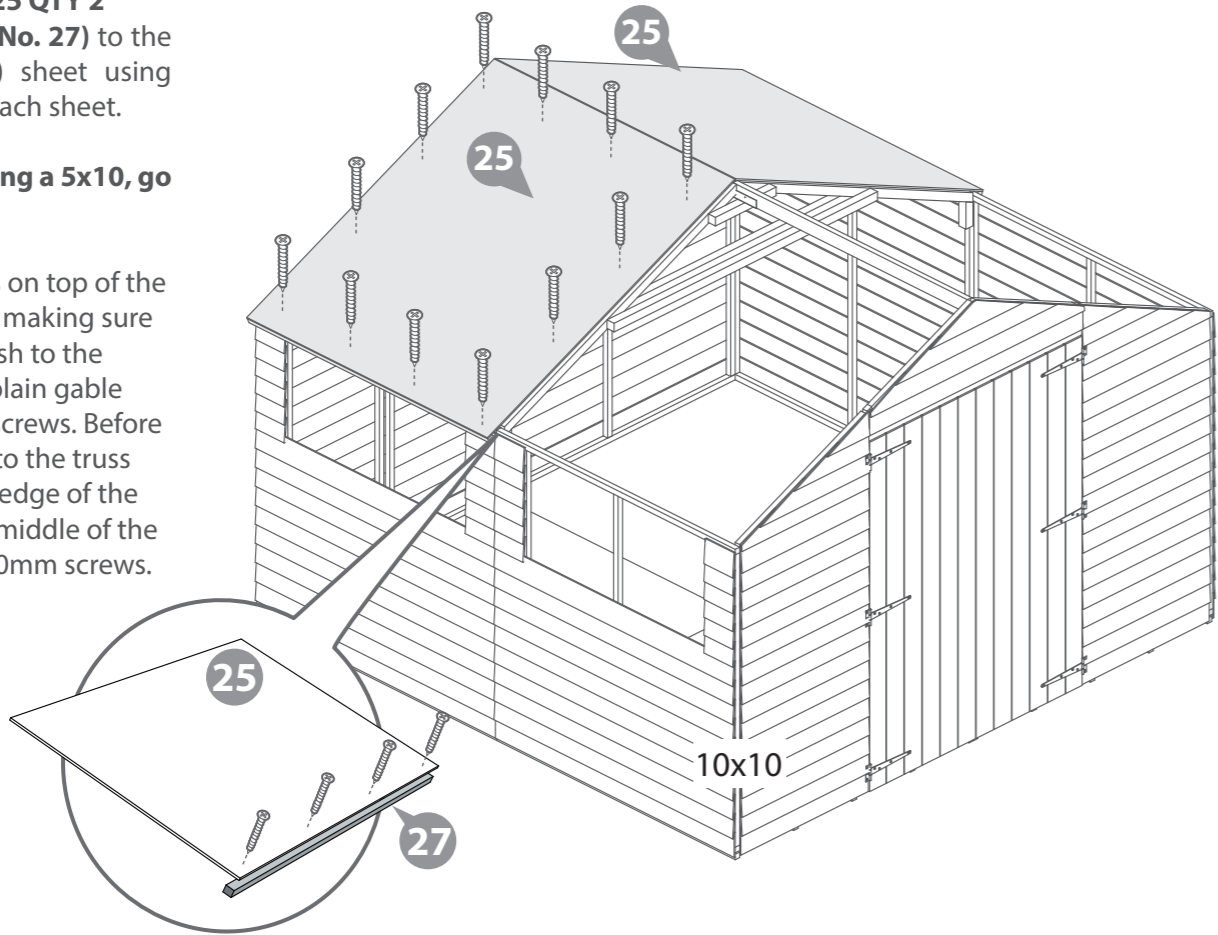
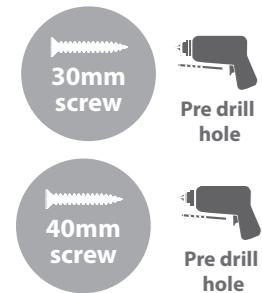

# Step 16

**Parts Needed -  
10x10 - No. 27 QTY 2  
No. 25 QTY 2  
15x10 - No. 27 QTY 4  
No. 25 QTY 4  
20x10 - No. 27 QTY 6  
No. 25 QTY 6**

Fix the remaining eaves frames to the remaining roof sheets using 4x30mm screws per sheet.

Place the roof sheet on top of the truss and ensure that it butts up to the one already fixed. Fix in place with 40mm screws ensuring they go through to the framing.

For 15x10 & 20x10 buildings continue this process until the roof is complete.

**10x10 - 8x30mm Screws  
24x40mm Screws  
15x10 - 16x30mm Screws  
48x40mm Screws  
20x10 - 24x30mm Screws  
72x40mm Screws**

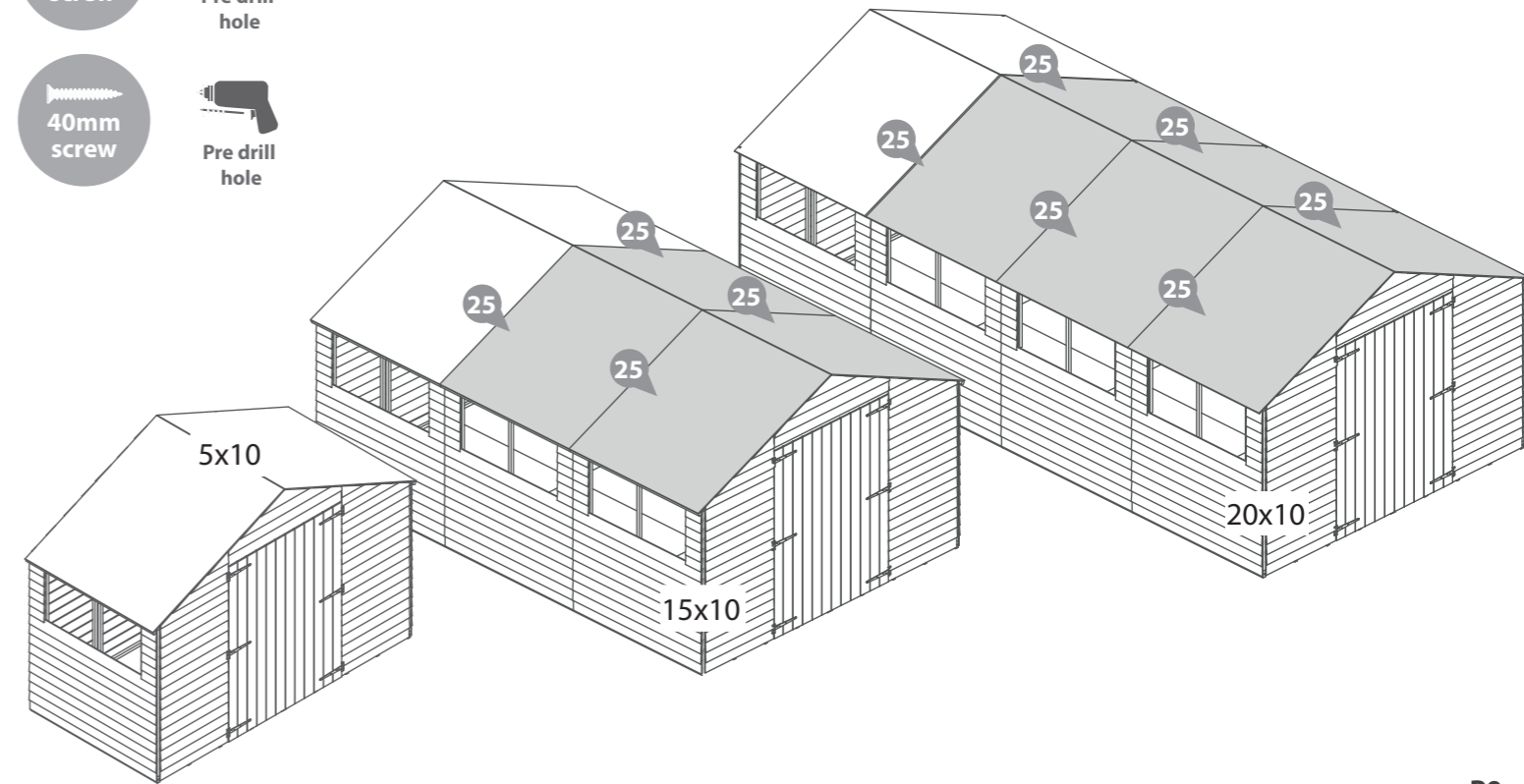

## Step 17

Once the roof is fixed, attach the building to the floor with 50 mm screws.

- 5x10 - 22 x 50mm Screws
- 10x10 - 26 x 50mm Screws
- 15x10 - 34 x 50mm Screws
- 20x10 - 42 x 50mm Screws

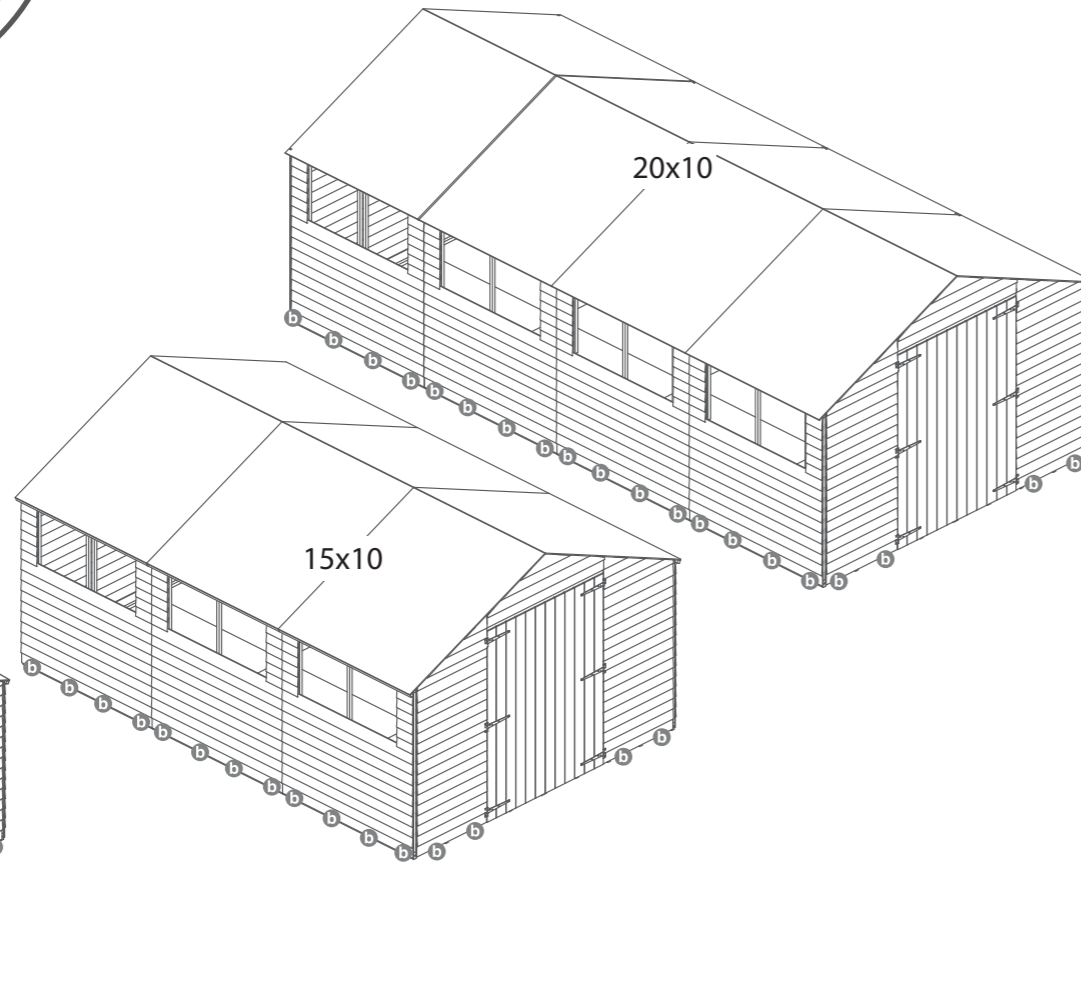
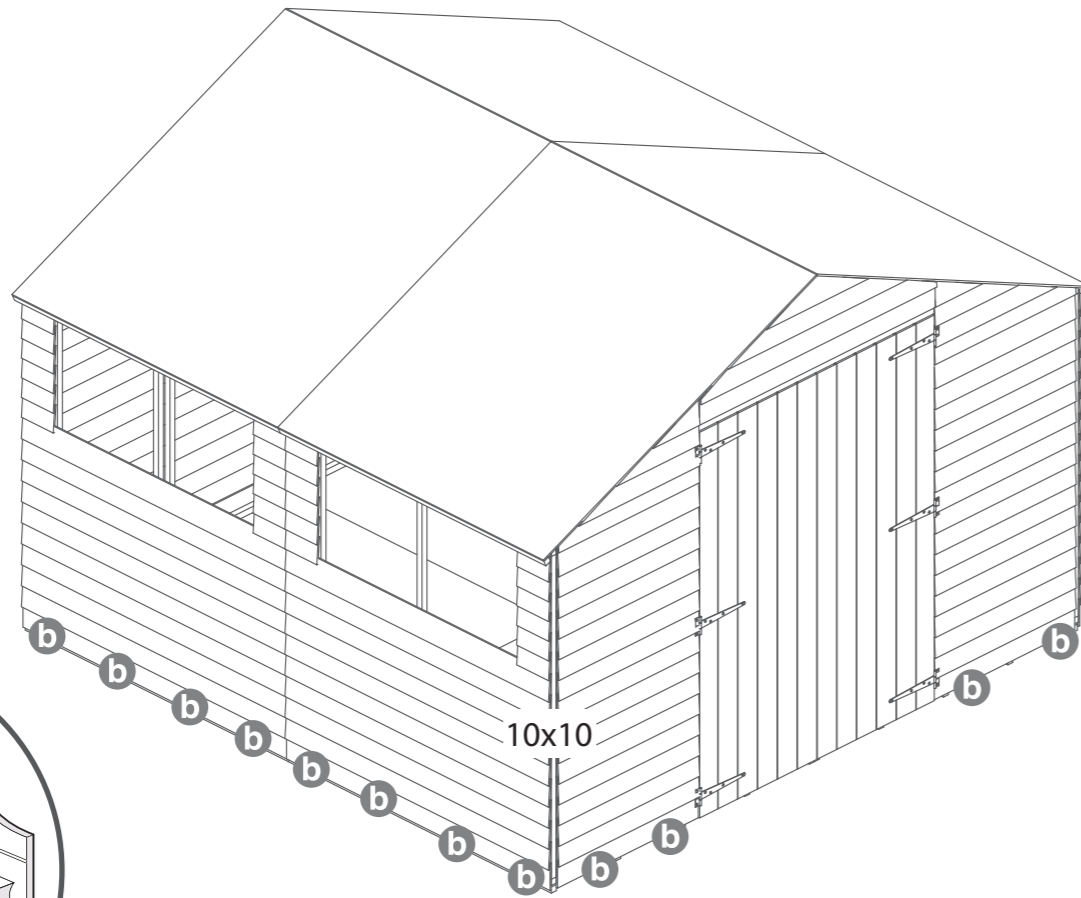
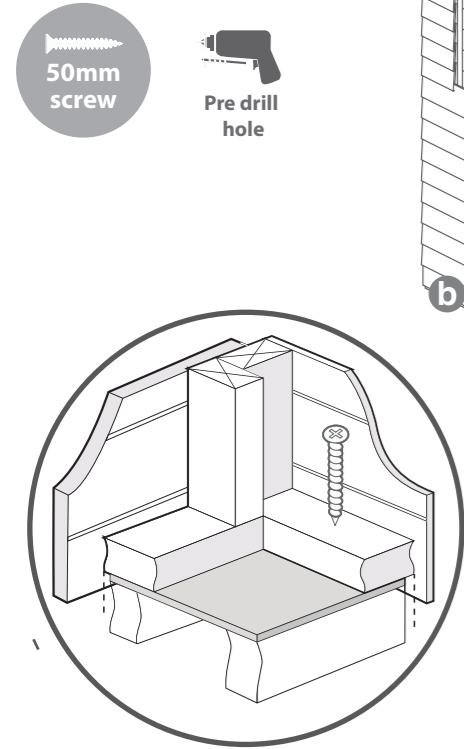

**IMPORTANT: Pre-drill before fixing screws.**

## Step 18

Cut four strips of felt (No. 21) and place onto the roof. See below for sizes.

Place the felt flat onto the roof in the order that is stated on the diagram below.

Once the sheets are laid out fix them onto the roof with tacks 100mm apart.

### Felt Strip Sizes

- 5x10 - 1610mm
- 10x10 - 3110mm
- 15x10 - 4610mm
- 20x10 - 6110mm

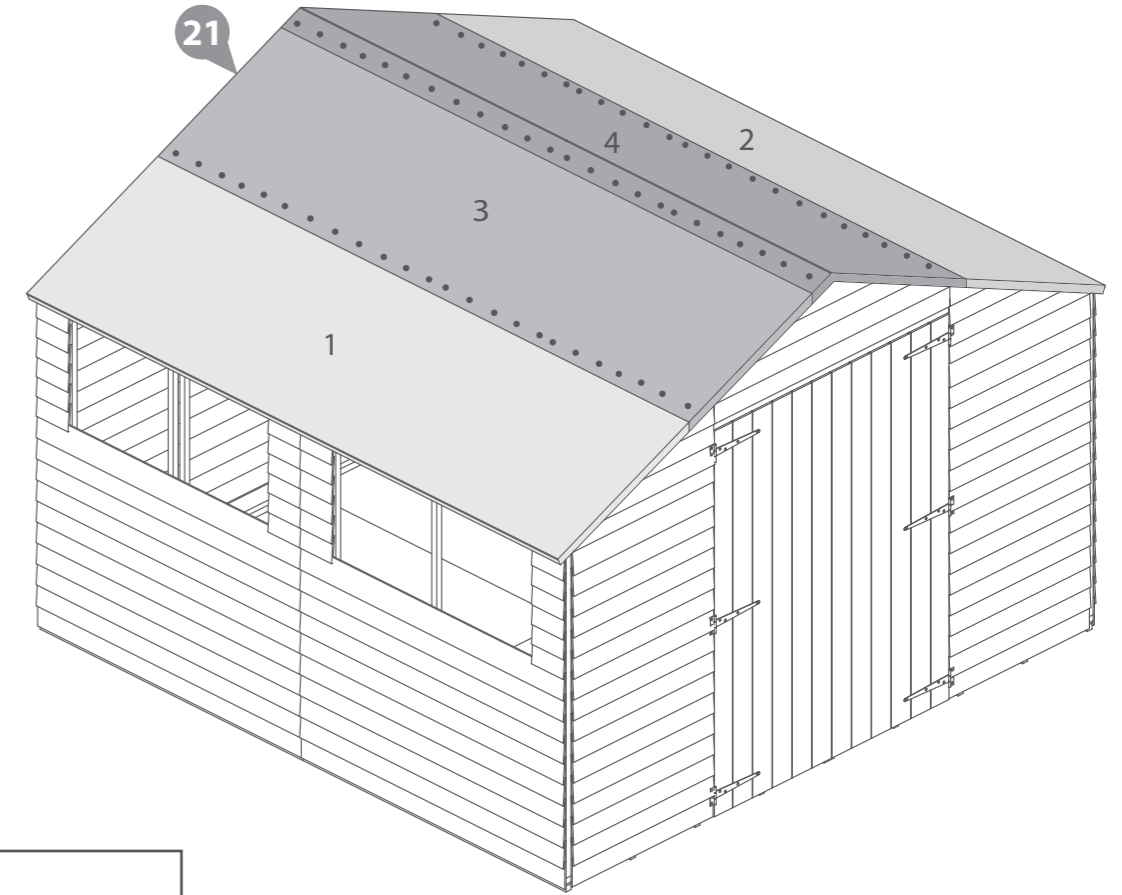
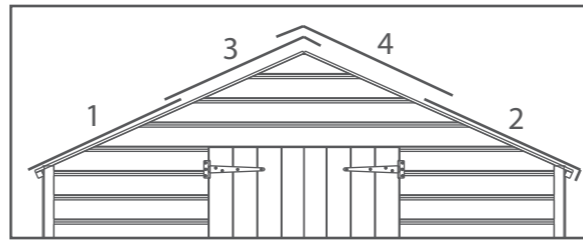

- 5x10 - 100 x felt tacks
- 10x10 - 170 x felt tacks
- 15x10 - 240 x felt tacks
- 20x10 - 310 x felt tacks

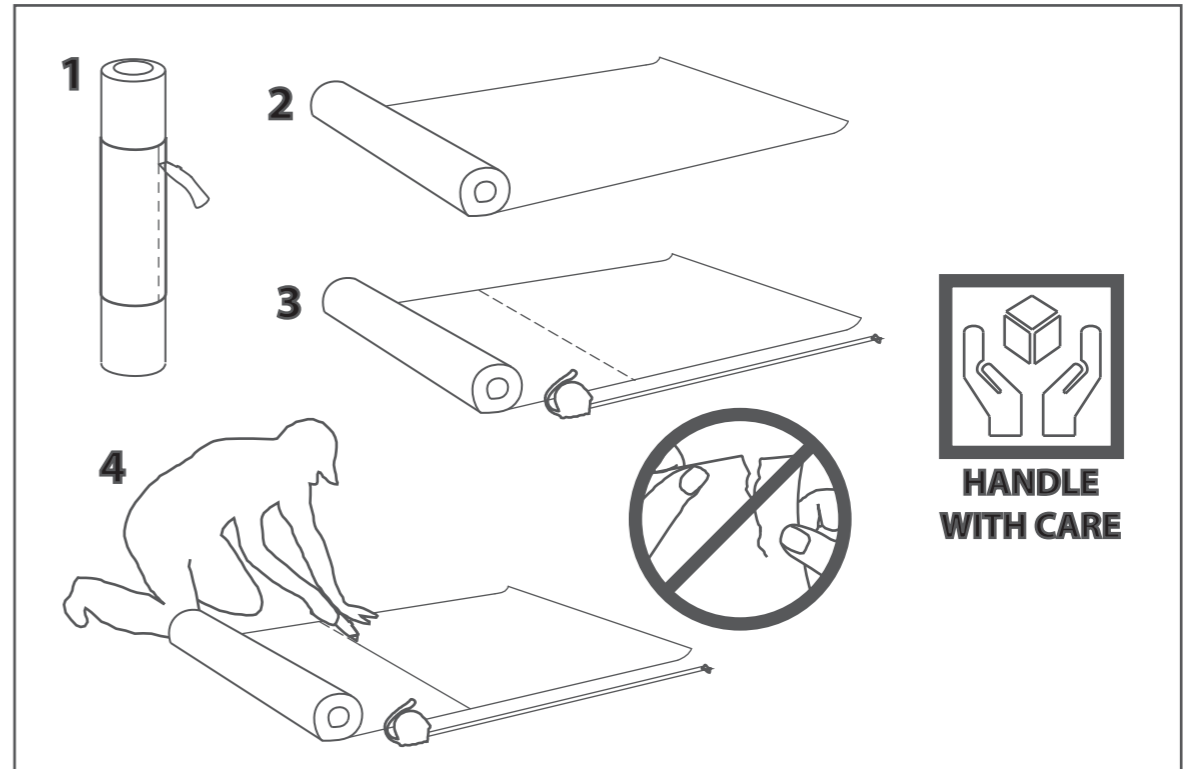



## Step 19

- Parts Needed -**  
 5x10 - No. 9 QTY 4  
 10x10 - No. 9 QTY 6  
 15x10 - No. 9 QTY 8  
 20x10 - No. 9 QTY 10

Using a pencil and a straight edge, measure the Strip (**No.9**) to **1575mm**.

Cut along the marked line to make a cover trim measuring 1575mm in length.

Fit the Cover Trims (**No. 9**) to the front, back and sides where the panels join using 3x40mm screws.

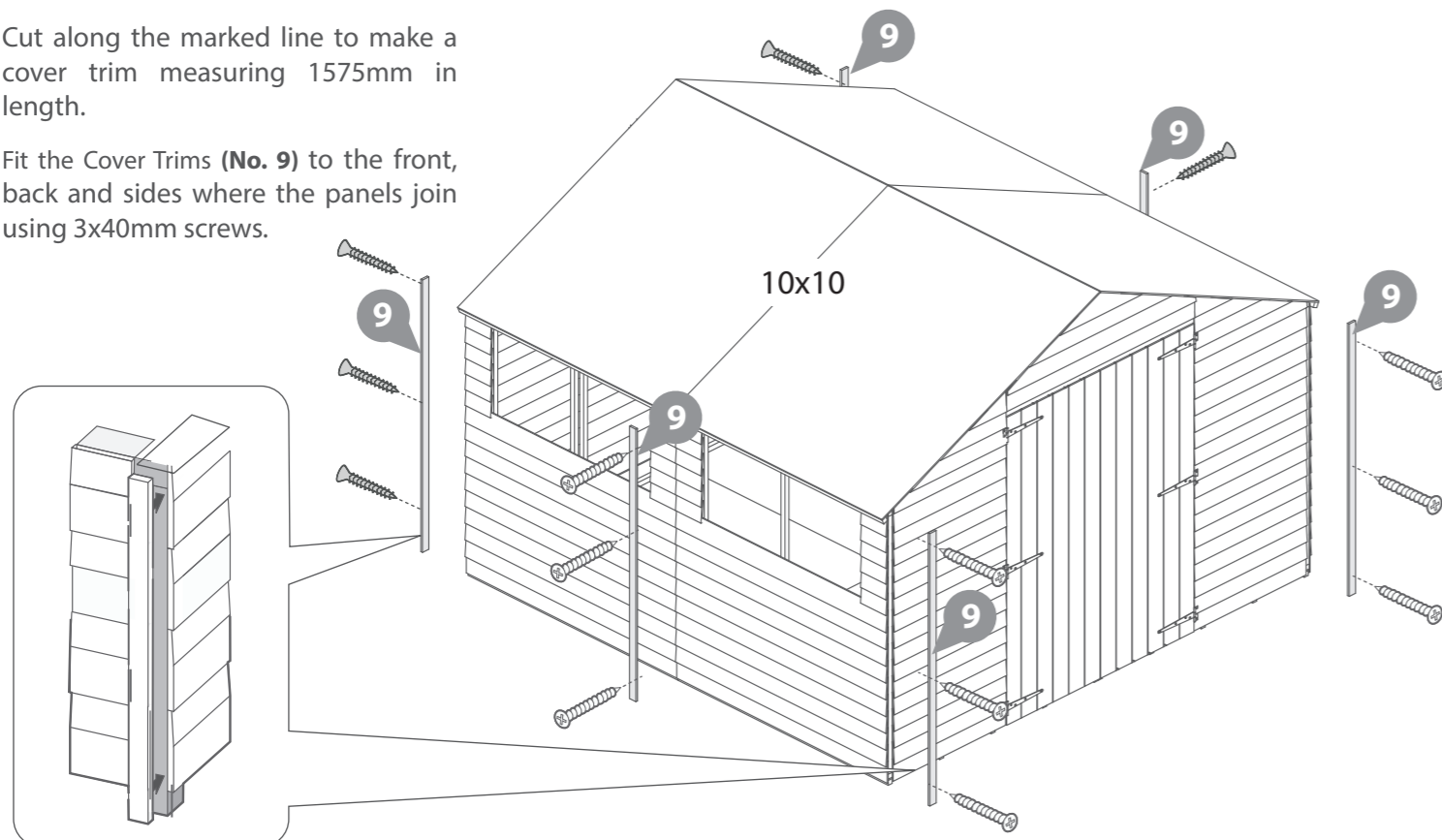

- 5x10 - 12x40mm Screws  
 10x10 - 18x40mm Screws  
 15x10 - 24x40mm Screws  
 20x10 - 30x40mm Screws

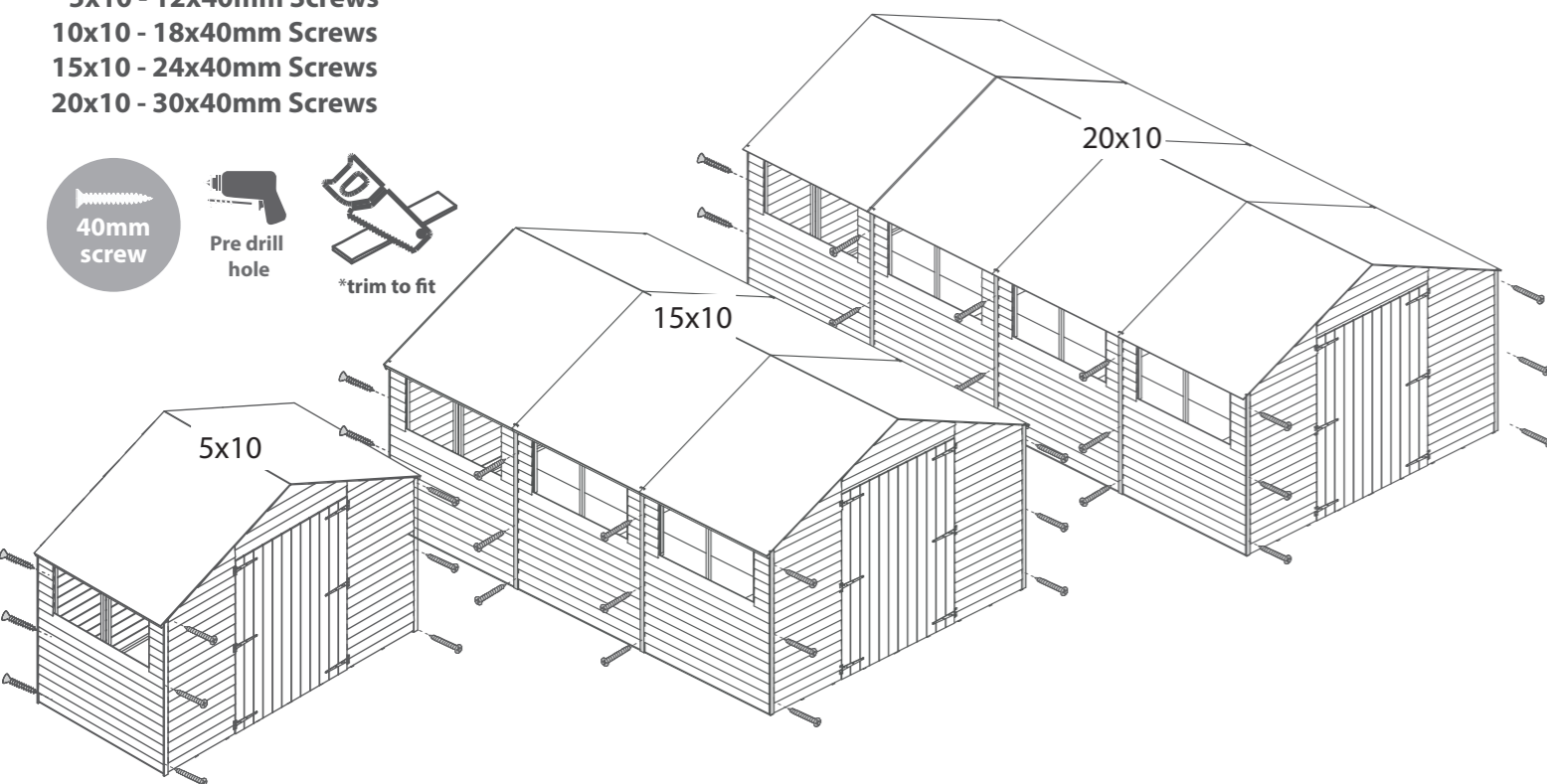

## Step 20

- Parts Needed - No. 15 QTY 1**

Locate the cover trim (**No.15**) on the back of the shed so it covers where the plain gable panels join together. Ensure the Trim sits centrally over the join, as shown in the illustration.

Secure in place using 3x40mm screws.

- 3 x 40mm Screws**

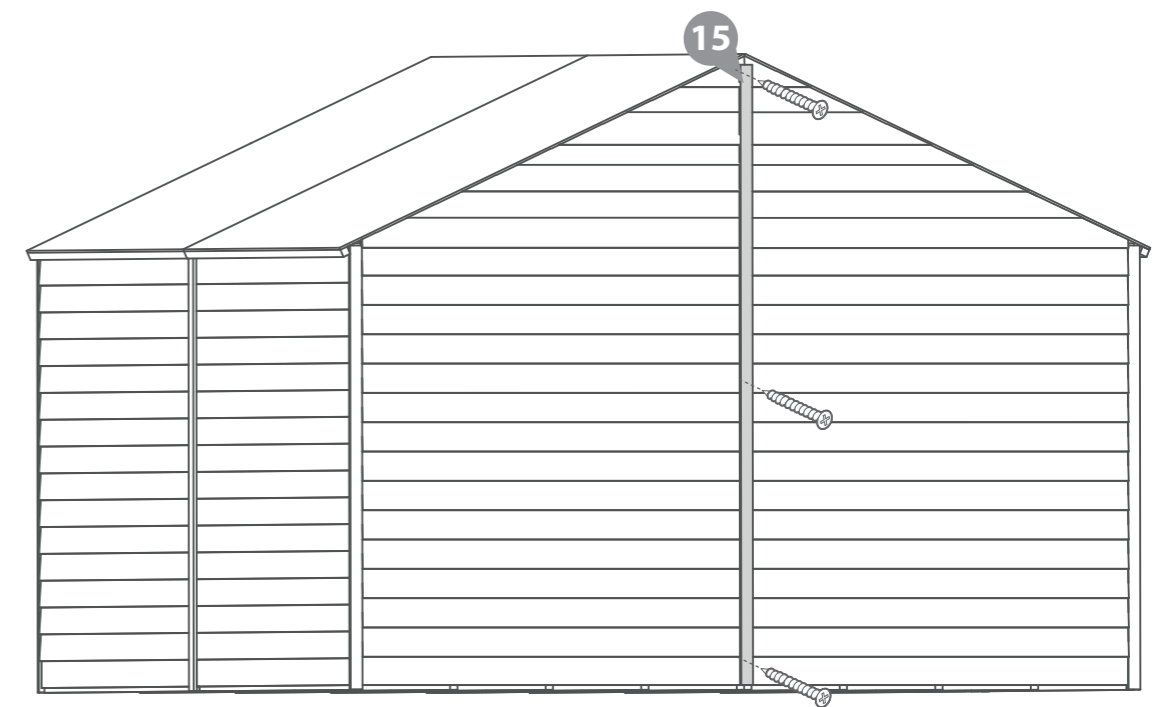
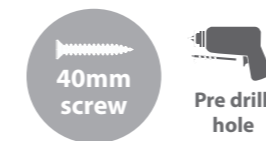

## Step 21

Parts Needed - No. 14 QTY 1

Using a pencil and a straight edge, measure the Strip (No. 14) to create two 250mm length strips.

Cut along the marked lines to make two cover trims measuring 250 mm in length.

Locate the cover trims onto the front gable, so they cover where the panels join together. Ensure the Trims sit centrally over the join, as shown in the illustration.

Secure in place using 3x40mm screws per cover trim.

4 x 40mm Screws

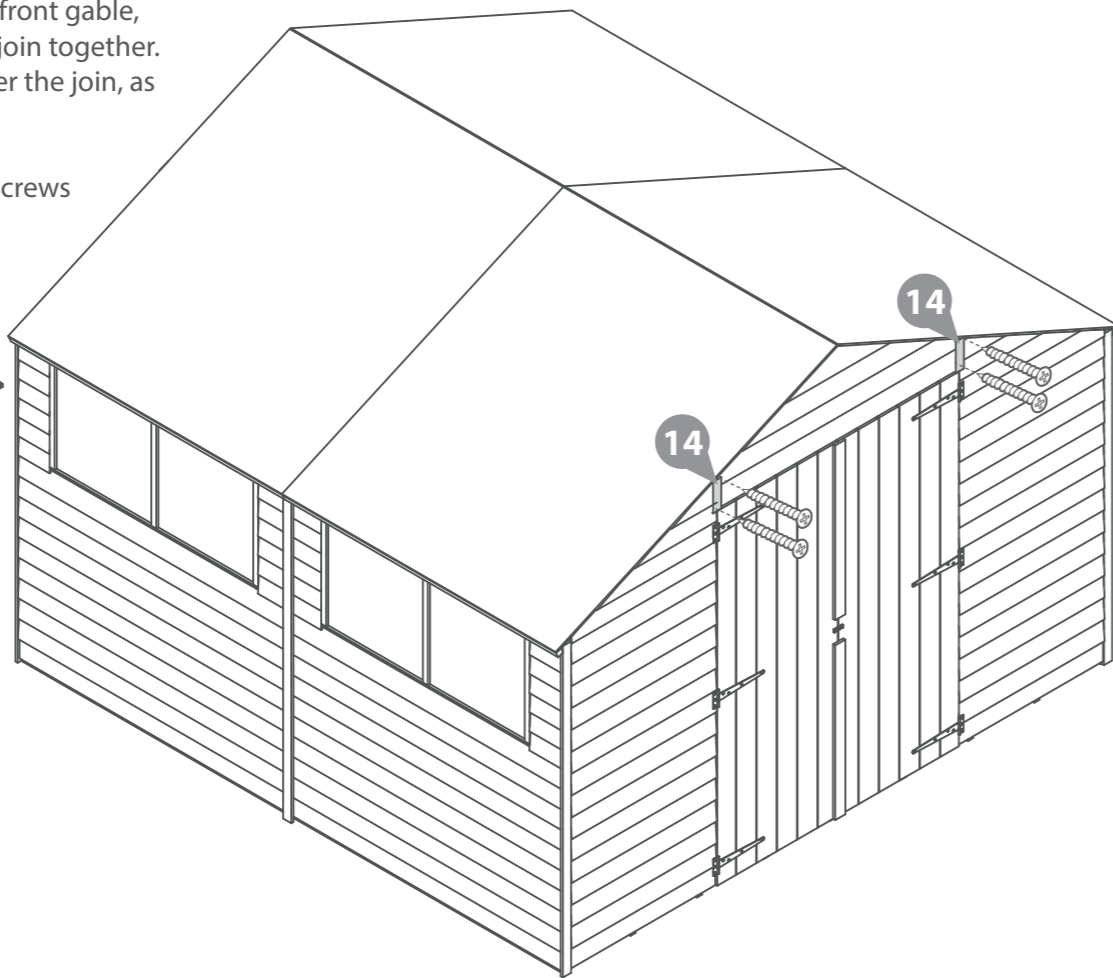

IMPORTANT: Pre-drill before fixing screws.

## Step 22

Parts Needed - No. 11 QTY 4

No. 18 QTY 2

Using a pencil and a straight edge, measure the Strip (No. 11) to 1667mm.

Cut along the marked lines to make a fascia measuring 1667mm in length.

Attach fascias to the roof leaving a slight overhang at the top.

Fit the fascias to the roof over the felt and secure in place with 40mm screws as shown. After the fascias are fitted, attach the two Finials (No. 18) to the front and the back using two screws per Finial. Pre drill to avoid splitting.

16x40mm Screws

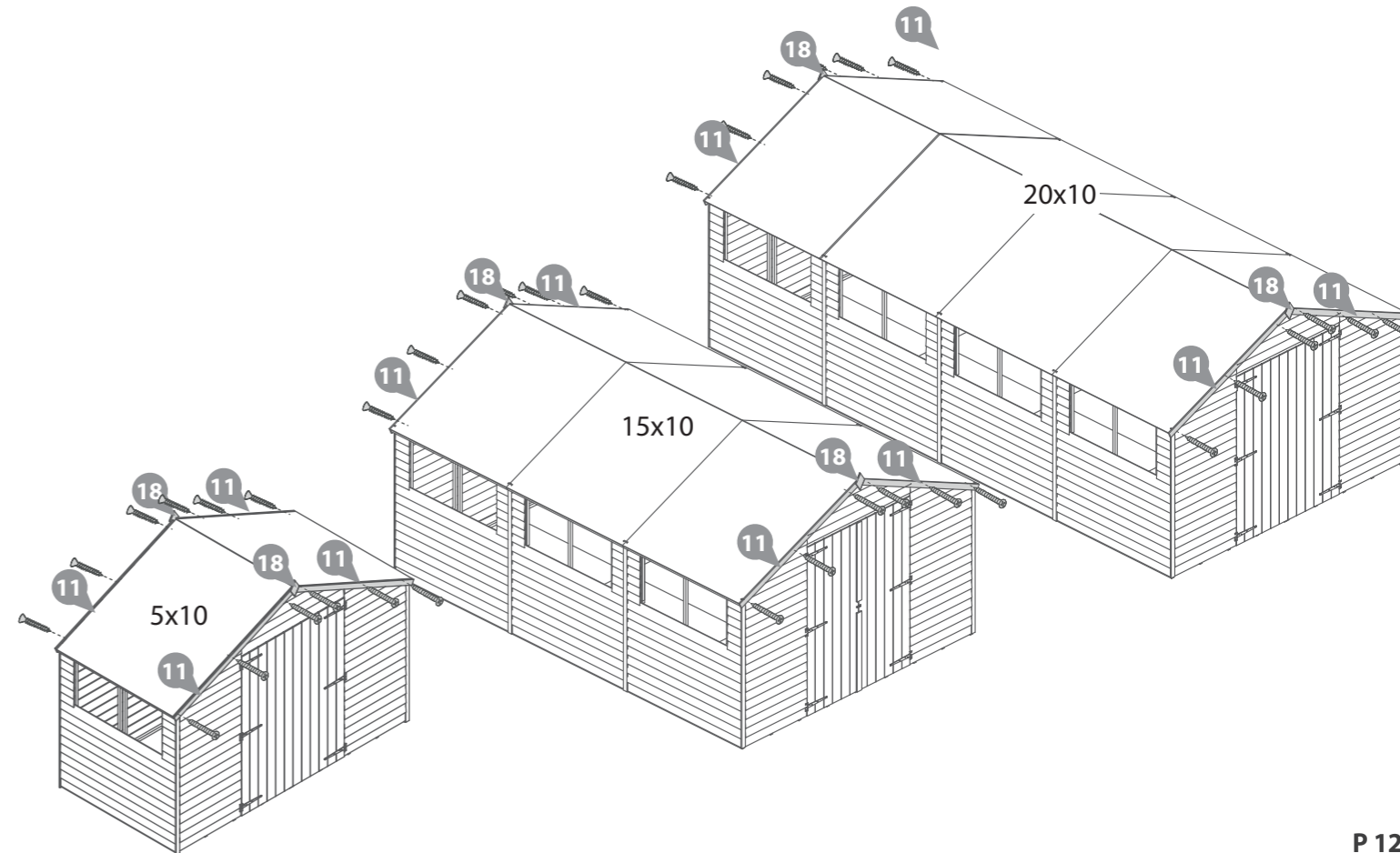

Please retain product label and IMPORTANT: Pre-drill before fixing screws.



# Step 23

Parts Needed - No. 10 QTY 2, No. 13 QTY 2 & No. 19 QTY 2

IMPORTANT: Pre-drill before fixing screws.

**a** First line up the door blocks (No.13) on top of the framing of the doors. Then fix with 2x30mm screws by screwing

**8x30mm Screws**

**b** Use 4x30mm Screws to fix each beading strip (No. 10) onto the door gable. Ensure that the screw is parallel with the door frame when fixing the strip to the door gable as shown in the close up view. Trim strips down to fit.

**8x30mm Screws**

**c** Attach the turn button (No.19) to the top and bottom door blocks with 1x30mm screw for each

**2x30mm Screws**

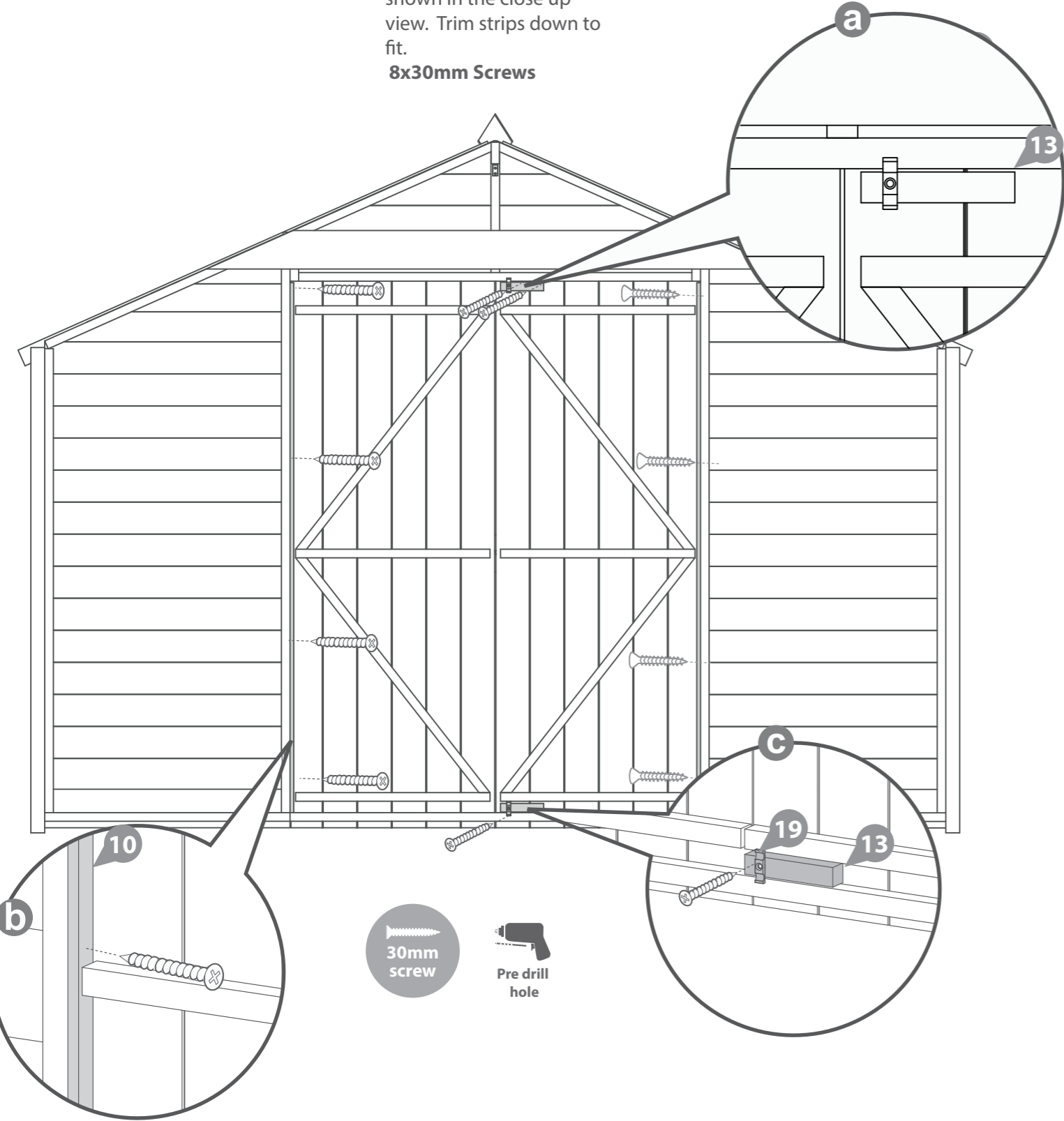

# Step 24

Parts Needed - No. 8 QTY 2 & No. 19 QTY 1

IMPORTANT: Pre-drill before fixing screws.

**a** Fix the door strips (No. 8) to the master door using 3x30mm screws per strip. Trim each strip down to approx 830mm each. If the strips are attached to the secondary door the doors will not open properly.

**6x30mm Screws**

**b** Use 1x30mm screw to secure the turn button (No. 19) to the master door.

**1x30mm Screws**

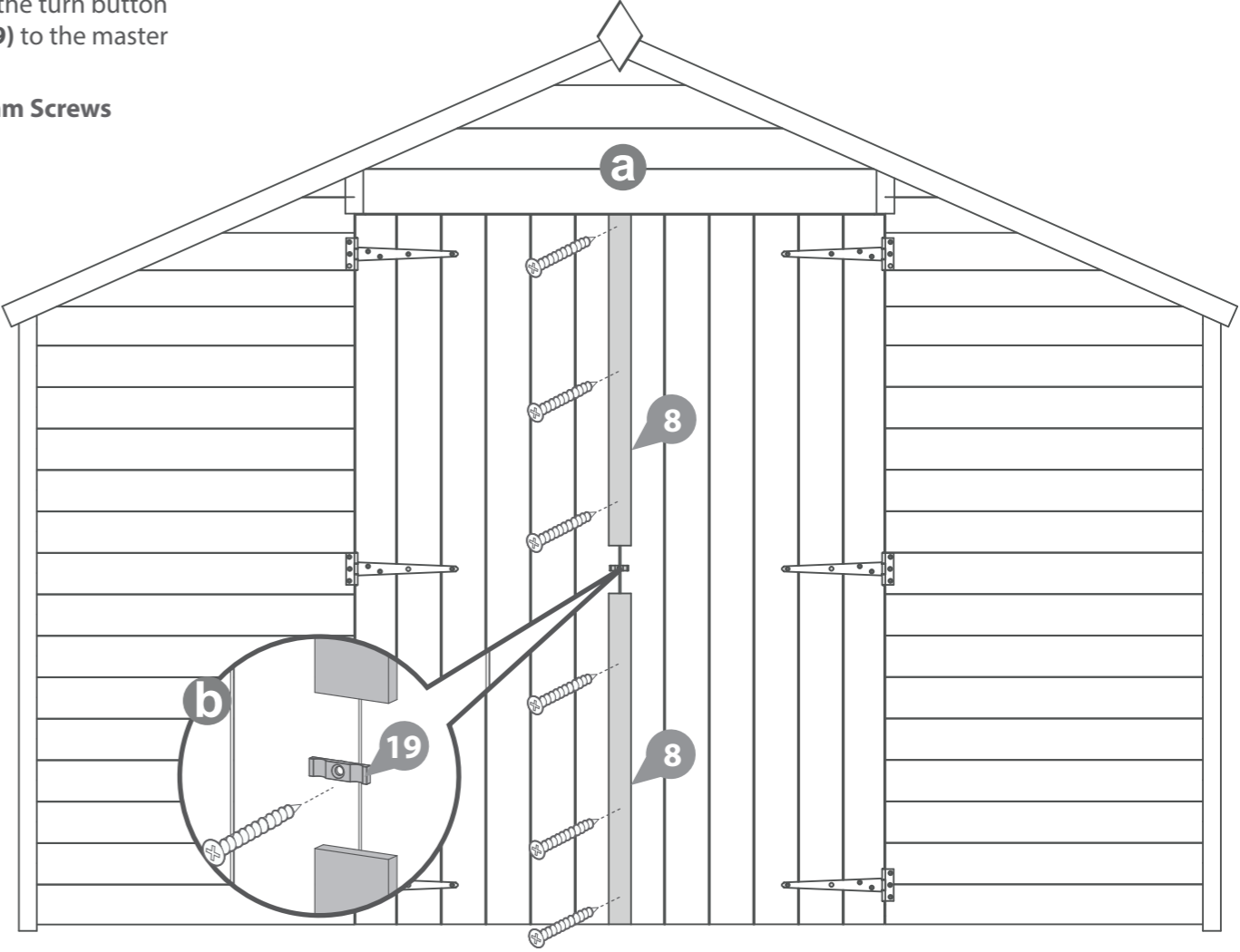

## Step 25 (Fixed Window only)

**IMPORTANT :** Pre-drill before fixing screws.

Parts Needed - No. 29 QTY 1

Using a pencil and a straight edge, measure the Strip (No. 32) to create **two 546mm length strips per window panel.**

Cut along the marked lines to make 2 window strips, each measuring 546mm in length.

*\*Please note you have excess strip left over, keep this to one side as you will require this in future steps.*

Fix 2 window strips to the framing that sits either side of the window, using 3x30mm screws per trim, as shown in the illustration.

Repeat this for both Window Panels.

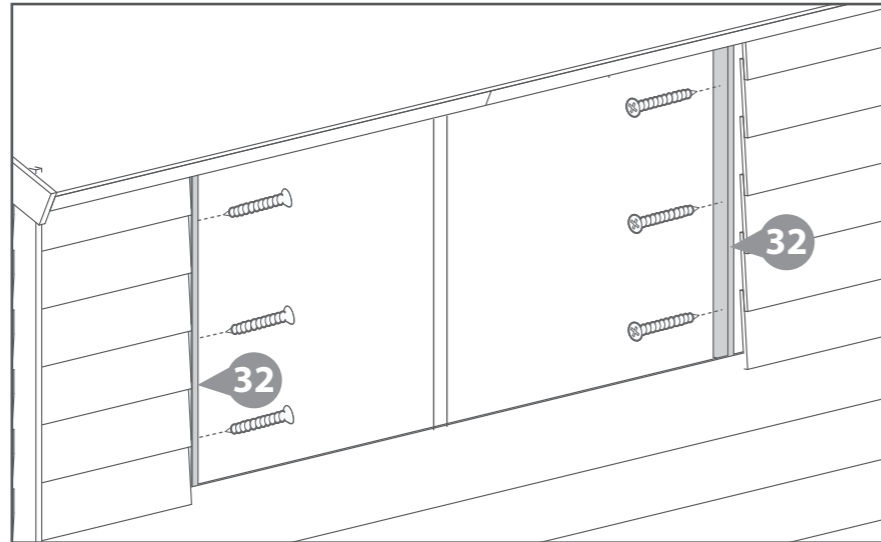

6 x 30mm Screws

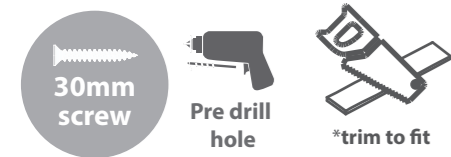

## Step 26 (Fixed Window only)

Parts Needed Per Window Side - No. 32 QTY 2  
No. 34 QTY 4

**a** Place the plastic window cill (No.34) onto the Window Panel and use a silicone sealant to secure in place, as shown in the illustration.

*\*please note silicone sealant is not supplied with your building\**

**b** Fit the styrene sheets (No.33) on top of the window cill (No.34).

When positioning the styrene sheets ensure there is an equal distance between them and either side of the windows.

Repeat for both Window Panels.

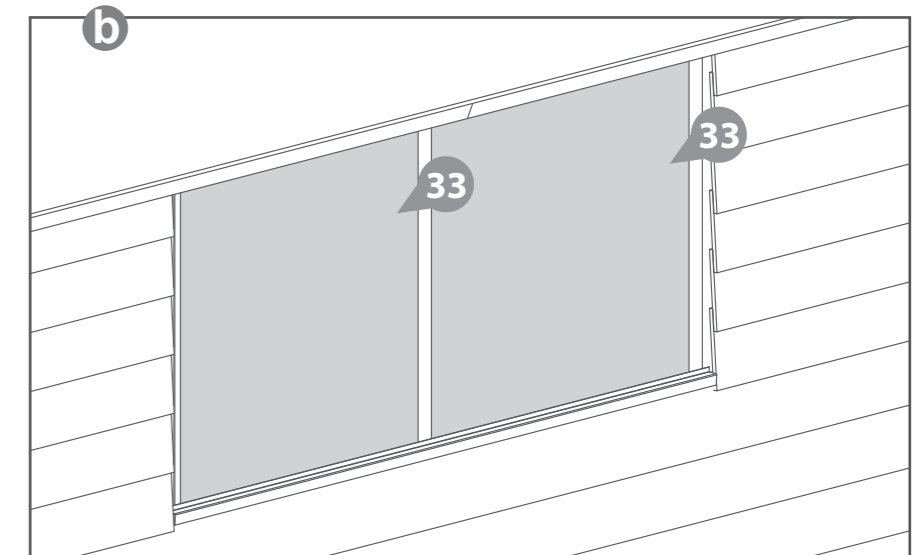
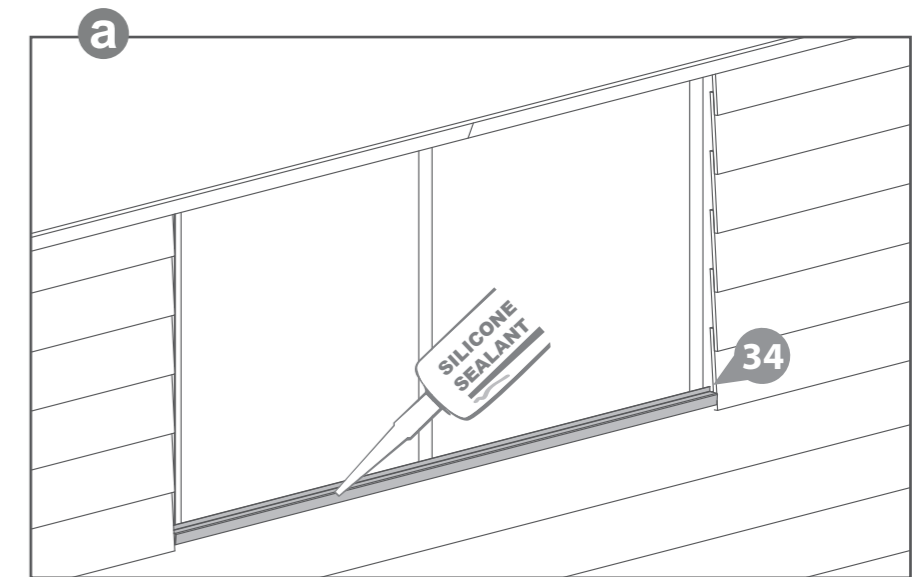
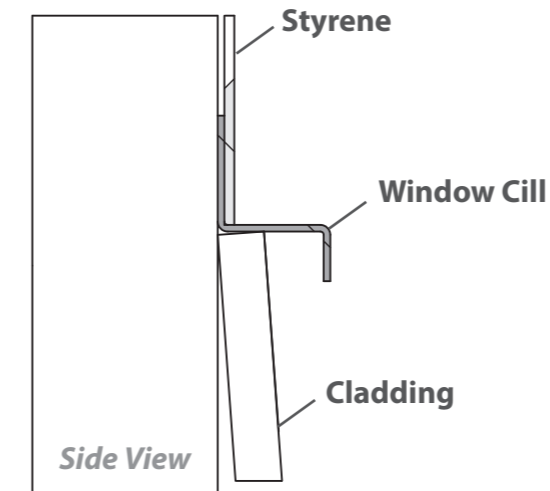



## Step 27 (Fixed Window only)

**IMPORTANT : Pre-drill before fixing screws.**

Parts Needed Per Window Side - No. 32 QTY 1

Using a pencil and a straight edge, measure the Strips (**No.32**) to create **three 546mm length strips**.

Cut along the marked lines to make 3 window strips in total, each measuring 546mm in length.

Locate the Window strips (**No. 32**) onto the Window Panel, one either side of the styrene slot in the panel and one in the centre of the two pieces of styrene, as shown in the illustration.

Fix in place using 3x30mm screws per Trim, ensuring the screws enter the framing of the window panel and not the styrene.

9 x 30mm screws.

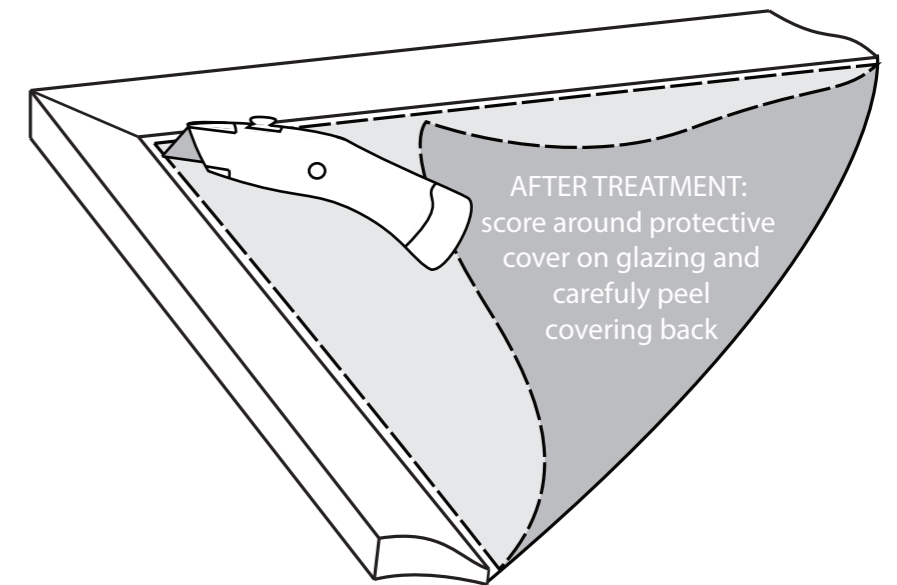
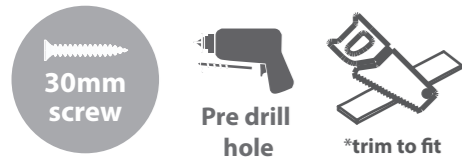
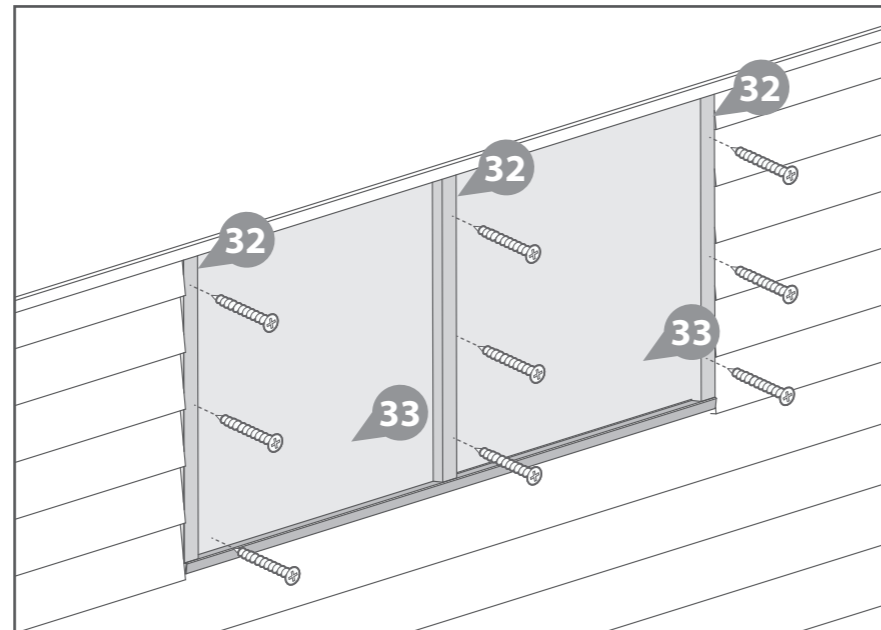
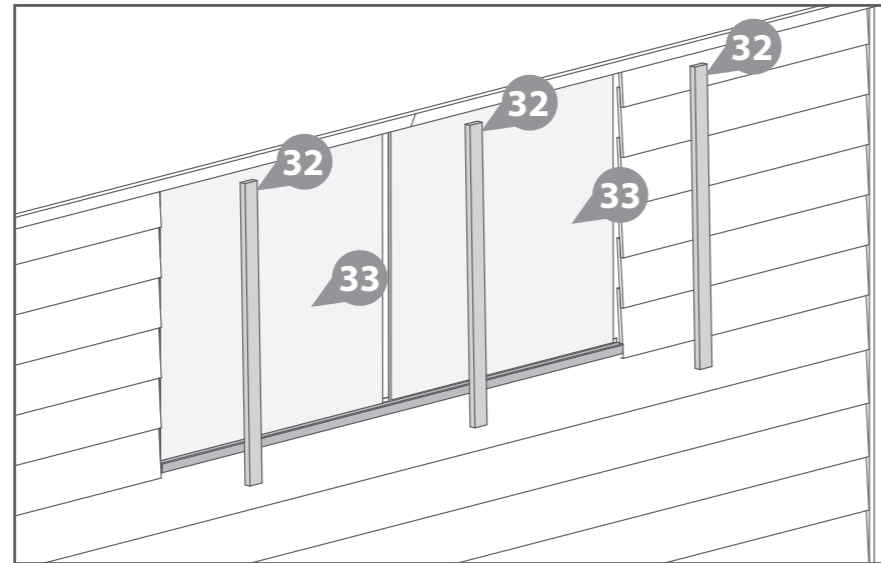

# MANUFACTURER'S RECOMMENDATIONS

All our garden buildings have been designed and manufactured with care and attention to be the perfect addition to your outdoor space. To ensure you do get the best out of your new garden building and to increase the longevity we advise that you follow the product instructions and our manufacturer's recommendations as detailed below. Thank you for choosing a Mercia Garden product!

## 1 Choosing the most suitable location for your garden building...

A minimum of 60cm should be left around the perimeter of your garden building to allow access for maintenance, annual treatment and to allow air flow around the building.

Where possible you should avoid placing your garden building underneath large trees to prevent the tree causing damage to the building.

## 2 Preparing the base for your garden building...

All our buildings must be built on a firm, level base to ensure the longevity of the building and prevent the wood from distorting. We recommend either concrete, concrete slabs or a wooden base, such as our 'Portabase'.

The base should be slightly smaller than the external measurement of the building, i.e. the cladding should overlap the base, creating a run off for water and preventing water from pooling underneath the building.

We also recommend that the floor of the garden building is a minimum of 25mm above the surrounding ground level to avoid flooding.

## 3 After installation...

Once your garden building has been installed it will need to be treated as soon as possible and annually to prevent the timber from deteriorating and to waterproof it. This is required to maintain the anti-rot guarantee.

Dip Treated buildings - Require a preservative treatment to protect against rot and decay and a waterproof treatment to prevent water ingress

Pressure Treated buildings - Require a waterproof treatment to prevent water ingress

Log Cabins/Insulated Garden Rooms - Are supplied untreated and require a preservative and waterproofing treatment

We also recommend using a silicon sealant on the inside and outside of the windows as soon as possible after assembly and treatment to fully seal the windows.

Roofing felt/covering should be checked annually and replaced or fixed accordingly.

## 4 General maintenance and wood characteristics

As wood is a natural material it may be affected by the following:

**Shrinkage and warping** - The timber used in the construction of your garden building will have retained some of its natural moisture content. The moisture content of the timber will vary, depending upon prevailing environmental conditions, which will result in the components either naturally expanding or contracting. As the components dry out shrinkage may occur. A good waterproofing treatment from the start is the best protection to minimise the effect of moisture loss/intake.

In extended periods of very warm weather getting some moisture to the building will help the overall balance. You can do this by spraying it down lightly with a garden hose. In contrast after snow fall try to remove the snow as best as possible from the roof to prevent moisture intake and to remove the extra weight.

Top tip - using a garden brush will help you to reach the highest part of the building to remove snow and any debris left from bad weather.

**Damp and mould** - During the winter months, cold and damp conditions can result in an increased amount of moisture within your garden building, especially when used infrequently. Condensation can form on the timber and other items stored within your garden building. If left this moisture is likely to cause mould and mildew. To prevent the build-up of moisture, we recommend leaving the door or windows of your building open from time to time, to allow the fresh air to circulate. We also advise against storing wet or damp items in your garden building as this will also increase the level of moisture in the building. If mould or mildew does start to form within your building we recommend using an anti-mould cleaner to remove it and to prevent it spreading, which if left untreated could permanently damage your garden building.

**Splits, cracks and knots** - You may notice small splits and cracks in some components or holes may appear where knots shrink and fall out. This will not affect the structure of your Garden building however if you wish to fill them this can be easily done using any good quality wood filler.

**Sap** - is naturally occurring in wood and may appear in some boards of your garden building. If you wish to remove the sap, we advise waiting until it is dry and then using a sharp knife to carefully remove it. If the removal of the sap causes a hole in the timber, we recommend using a good quality wood filler to fill it.

For more handy hints and tips on how to care and maintain your garden building please refer to the MGP Customer Portal at [www.mgplogistics.co.uk](http://www.mgplogistics.co.uk)

Any further questions?

Contact our  
Customer Service  
Team on:  
01636 821215

## 1 Manufacturer's Warranty

All Mercia Garden Products are supplied with a 1 year warranty on all parts against manufacturing defects.  
This warranty does not cover movement, warping or splitting of timber products over time.

This warranty will be voided if any of the following occur:

1. The building has been customised or modified/adapted in any way.
2. The person claiming is not the original purchaser of the building.
3. Any damage has been caused by or as a result of misuse.
4. The building has not been maintained and cared for in accordance to our advisories and manufacturer's recommendations.
5. The building has not been treated annually or as per the manufacturer's recommendations, please ensure receipts are kept to validate this claim.
6. The building has not been erected, fitted or installed as per the supplier instructions.
7. The building has not been erected on a suitable sized firm flat, solid level concrete/slab base or placed on pressure treated bearers.
8. The building is or has been placed with 2 feet (60cm) of any obstructions (walls, trees, plants, fences etc.) which can allow moisture to penetrate the timber.
9. The roofing felt has been incorrectly fitted or damaged allowing water ingress, or not properly maintained.
10. Any windows and joints have not been sealed, inside and out, with silicone or other watertight sealant.
11. Any timber has been cut, pierced or drilled without subsequent application of approved cut-end treatment.

## 2 Anti-rot Guarantee

Mercia Garden Products offer a 10 year anti-rot guarantee on all dip treated (a preparatory treatment) and 15 years on all pressure treated products. This guarantee covers solid timber against rot, decay, blue stain and insect attack.

To validate the guarantee the building must be treated with a recognised wood preserver/water proof top coat (as detailed within manufacturer's recommendations) as soon as possible after assembly and annually thereafter.

This guarantee does not cover movement, warping or splitting of timber products over time.

This guarantee will be voided if any of the following occur:

1. The building has been customised or modified/adapted in any way.
2. The person claiming is not the original purchaser of the building.
3. Any damage is caused by or as a result of misuse.
4. The building has not been maintained and cared for in accordance to our advisories and manufacturer's recommendations.
5. The building has not been treated annually or as per the manufacturer's recommendations, please ensure receipts are kept to validate this claim.
6. The building has not been erected, fitted or installed as per the supplier instructions.
7. The building has not been erected on a suitable sized firm flat, solid level concrete/slab base or placed on pressure treated bearers.
8. The building is or has been placed with 2 feet (60cm) of any obstructions (walls, trees, plants, fences etc.) which can allow moisture to penetrate the timber.
9. The roofing felt has been incorrectly fitted or damaged allowing water ingress, or not properly maintained.
10. Any windows and joints have not been sealed, inside and out, with silicone or other watertight sealant.
11. Any timber has been cut, pierced or drilled without subsequent application of approved cut-end treatment.



REGISTER FOR YOUR  
**ANTI-ROT**  
GUARANTEE TODAY

PLEASE SCAN HERE:

