

03DTSHCV0808HGD4MW-V1

DIP TREATED SHIPLAP CURVED 8FT X 8FT HALF GLAZED DOUBLE 4 MEDIUM WINDOW

### BEFORE YOU START PLEASE READ INSTRUCTIONS CAREFULLY

- Check the pack and make sure you have all the parts listed.
- When you are ready to start, make sure you have the right tools at hand (not supplied) including a Phillips screwdriver, Stanley knife, Wood saw, Step ladder, Hammer and a Drill with 2mm bit.
- Ensure there is plenty of space and a clean dry area for assembly.

### LOCATION FOR YOUR GARDEN BUILDING

A minimum of 60cm should be left around the perimeter of your garden building to allow access for maintenance, annual treatment and to allow air flow around the building.

Where possible you should avoid placing your garden building underneath large trees to prevent the tree causing damage to the building.

### TIMBER

As with all natural materials, timber can be affected during various weather conditions. For the duration of heavy or extended periods of rain, swelling of the wood panels may occur. Warping of the wood may also occur during excessive dry spells due to an interior moisture loss. Unfortunately, these processes cannot be avoided but can be helped. It is suggested that the outdoor building is sprayed with water during extended periods of warm sunshine and sheltered as much as possible during rain or snow.

Once your garden building has been installed it will need to be treated as soon as possible and annually to prevent the timber from deteriorating and to waterproof it. This is required to maintain the anti-rot guarantee.

Dip Treated buildings - Require a preservative treatment to protect against rot and decay and a waterproof treatment to prevent water ingress

Pressure Treated buildings - Require a waterproof treatment to prevent water ingress

Log Cabins - Are supplied untreated and require a preservative and waterproofing treatment.

### BUILDING A BASE

When thinking about where the building and base is going to be constructed:  
Ensure that there will be access to all sides for maintenance work and annual treatment.

Ensure the base is level and is built on firm ground, to prevent distortion. Refer to diagrams for the base dimensions, The base should be slightly smaller than the external measurement of the building, i.e. The cladding should overlap the base, creating a run off for water. It is also recommended that the floor be at least 25mm above the surrounding ground level to avoid flooding.

### TYPES OF BASE

- Concrete 75mm laid on top of 75mm hard-core.
- Slabs laid on 50mm of sharp sand.

**Whilst all products manufactured are made to the highest standards of Safety and in the case of childrens products independently tested to EN71 level, we cannot accept responsibility for your safety whilst erecting or using this product.**



x2

All buildings should be erected by two adults



Winter = High Moisture = Expansion  
Summer = Low Moisture = Contraction



2mm Drill bit

For ease of assembly, you **MUST** pilot drill all screw holes and ensure all screw heads are countersunk.



### CAUTION

Every effort has been made during the manufacturing process to eliminate the prospect of splinters on rough surfaces of the timber. You are strongly advised to wear gloves when working with or handling rough sawn timber.



For ease of assembly, you will need a tape measure to check dimensions of components.

Screws & Nails

Measure overall length

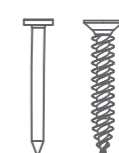

Bolts

Measure under the head



To identify the fixings required for each step use a measuring tape.

### \*\*Protim Aquatan T5 (621)\*\*

Your building has been dip treated with **Aquatan**.

Aquatan is a water-based concentrate which is diluted with water, the building has been treated by the correct application of Aquatan solution and then allowed to dry.

Aquatan is a decorative finish to colour the wood, which is applied industrially to timber fence panels and garden buildings.

**Aquatan undiluted contains:** boric acid, sodium hydroxide 32% solution, aqueous mixture of sodium dioctyl sulphosuccinat and alcohols: 2, 4, 6-trichlorophenol.



## REGISTER FOR YOUR ANTI-ROT GUARANTEE TODAY

PLEASE SCAN HERE:



For assistance please contact customer care on: 01636 821215

**Mercia Garden Products Limited,**  
Sutton On Trent,  
Newark,  
Nottinghamshire,  
NG23 6QN

[www.merciagardenproducts.co.uk](http://www.merciagardenproducts.co.uk)







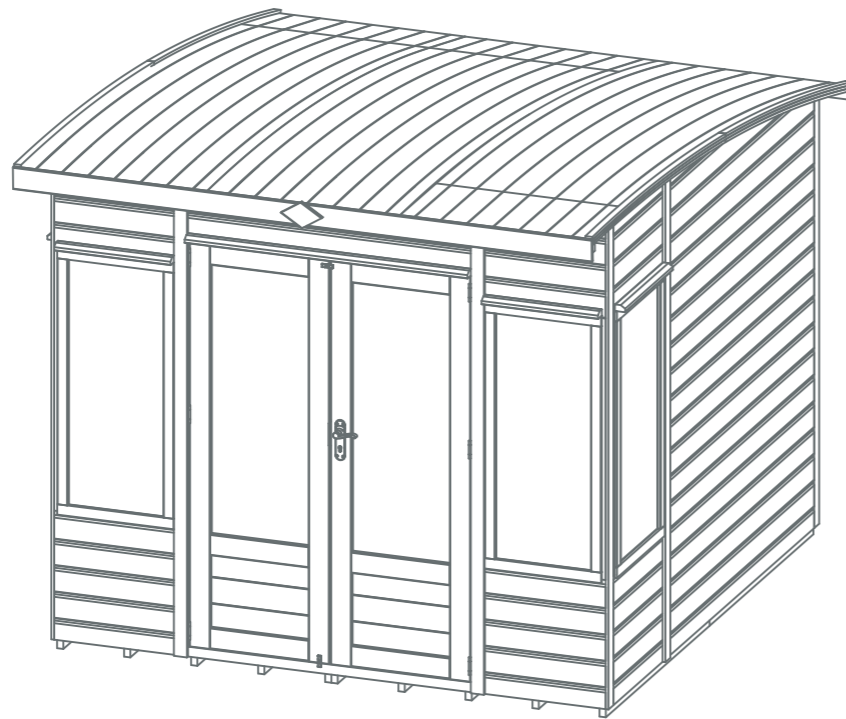



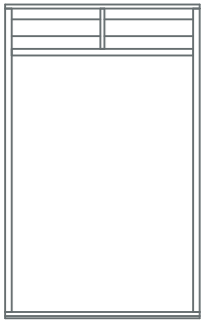
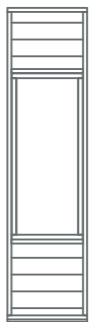
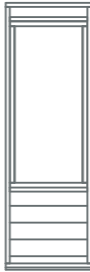
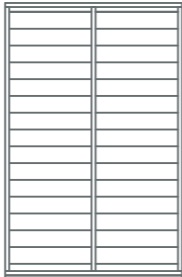
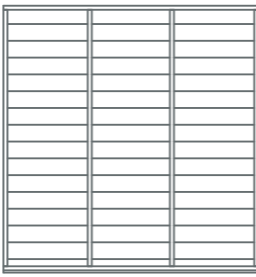

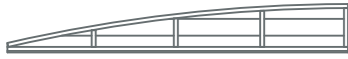















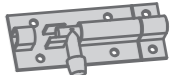

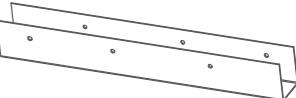

Overall Dimensions:  
 Length = 2963mm  
 Width = 2476mm  
 Height = 2157mm

Base Dimensions:  
 Length = 2350mm  
 Width = 2350mm

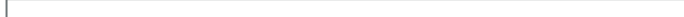

## Building Content:

 <b>1</b> <b>Door Panel</b> <b>QTY 1</b> <small>AI-03S22SHDD1298X2095-V1</small>	 <b>2</b> <b>Front Window Panel</b> <b>QTY 2</b> <small>AI-03S21SH1FSFWC531X2095-V1</small>	 <b>3</b> <b>Side Window Panel</b> <b>QTY 2</b> <small>AI-03S21SH1FSFWC572X1782-V1</small>	 <b>4</b> <b>Back Panel</b> <b>QTY 2</b> <small>AI-S21SHPP1180X1832-V1</small>	 <b>5</b> <b>Side Panel</b> <b>QTY 2</b> <small>AI-S21SHPPTF1700X1782-V1</small>	
 <b>6</b> <b>Left Gable</b> <b>QTY 1</b> <small>AI-S21SHCGTL2272X323-V1</small>	 <b>7</b> <b>Right Gable</b> <b>QTY 1</b> <small>AI-S21SHCGTR2272X323-V1</small>	 <b>8</b> <b>Floor</b> <b>QTY 4</b> <small>AI-S21MBF1175X1175-V1</small>	 <b>9</b> <b>Roof</b> <b>QTY 3</b> <small>AI-S21MBCR825X2950-V1</small>	 <b>10</b> <b>Master Door</b> <b>QTY 1</b> <small>AI-PRMHGMD600X1715-V1</small>	 <b>11</b> <b>Secondary Door</b> <b>QTY 1</b> <small>AI-PRMHGSD600X1715-V1</small>

 <b>12</b> <b>Roof Block - 28x28x140mm QTY 6</b> <small>FS2828-G-160mm (angled)</small>	 <b>26</b> <b>Mortice Lock</b> <small>PI-07-0017</small>
 <b>13</b> <b>Door Rain Guard - 28x44x1210mm QTY 1</b> <small>RG2844-1210mm</small>	 <b>27</b> <b>Key Plate</b>
 <b>14</b> <b>Side Window Rain Guard - 28x44x540mm QTY 2</b> <small>RG2844-540mm</small>	 <b>28</b> <b>Hinge QTY 6</b> <small>PI-07-0023</small>
 <b>15</b> <b>Front Window Rain Guard - 28x44x498mm QTY 2</b> <small>RG2844-498mm</small>	 <b>29</b> <b>Turn Button QTY 2</b> <small>PI-07-0034</small>
 <b>16</b> <b>Door Beading - 17x12x1711mm QTY 2</b> <small>S1217-1711mm</small>	 <b>30</b> <b>Tower Bolt QTY 2</b> <small>PI-07-0114</small>
 <b>17</b> <b>Roof Trim - 30x12x1510mm QTY 8</b> <small>S1230-1510mm</small>	 <b>31</b> <b>Finial QTY 1</b> <small>Shed Diamond Finial</small>
 <b>18</b> <b>Fascia - 95x12x1238mm QTY 2</b> <small>SR1295-1238mm</small>	 <b>32</b> <b>Door Handle</b> <small>PI-07-0001</small>
 <b>19</b> <b>Front Cover Trim - 56x12x2088mm QTY 4</b> <small>S1256-2088mm</small>	 <b>33</b> <b>U Channel QTY 2</b> <small>PI-07-0013</small>
 <b>20</b> <b>Side Cover Trim - 56x12x2070mm QTY 2</b> <small>S1256-2070mm</small>	 <b>34</b> <b>Felt</b>
 <b>21</b> <b>Rear Cover Trim - 56x12x1810mm QTY 3</b> <small>S1256-1810mm</small>	
 <b>22</b> <b>Ridge Bar - 90x40x2272mm QTY 3</b> <small>F4090-2272mm</small>	
 <b>23</b> <b>Door Bar - 60x16x1705mm QTY 1</b> <small>S1660-1705mm</small>	
 <b>24</b> <b>Floor Block - 44x27x400mm QTY 8</b> <small>F2744-400mm</small>	
 <b>25</b> <b>Roof End - 100x12x2950mm QTY 3</b> <small>MB12RT100-2950mm</small>	

# Nail Bag

There may be extra screws present in the nail bag

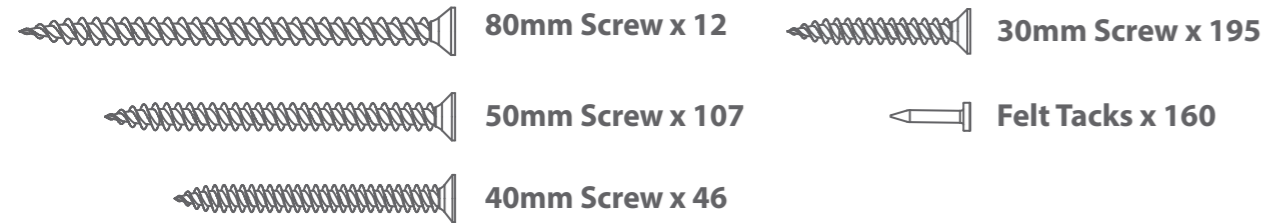

## Pre Assembly

Before assembling remove the transportation blocks from the bottom of each panel.

Take care removing the blocks as to not damage the panels. Tap with a flat headed screwdriver and hammer.

Dispose of the blocks once removed.

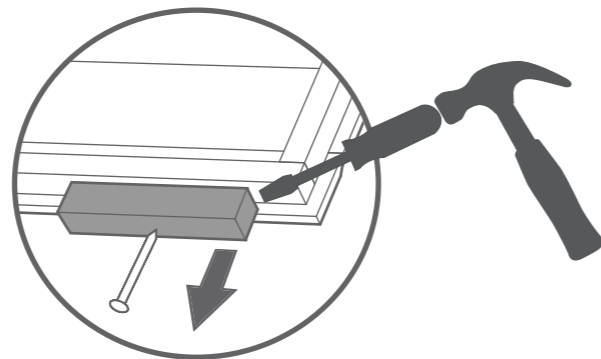

## Step 1

- Parts Needed - No. 1 QTY 1**  
 - **No. 10 QTY 1**  
 - **No. 11 QTY 1**  
 - **No. 26 QTY 1**  
 - **No. 27 QTY 1**  
 - **No. 28 QTY 6**  
 - **No. 32 QTY 1**

**a** Join the hinges (**No.28**) to the door frames (**No.10 & 11**) using 40mm screws. Ensure hinges are attached using the outer plate of the hinge.

Fit the doors to the Door Panel (**No.1**) with 40mm screws making sure to use the inner plate of the hinge.

**b** Fit the Mortice Lock (**No.26**) into the recess and fix in place with the screws provided. Fit the Key Plate (**No. 27**) to the opposite door using the screws provided.

**c** Fix the Door Handles (**No.32**) and the metal bar (spindle) using 8x30mm screws. Ensure the mortice lock closes correctly. If not, remove lock and turn the catch around using the small grub screw.

**8x30mm screws**  
**36x40mm screws**

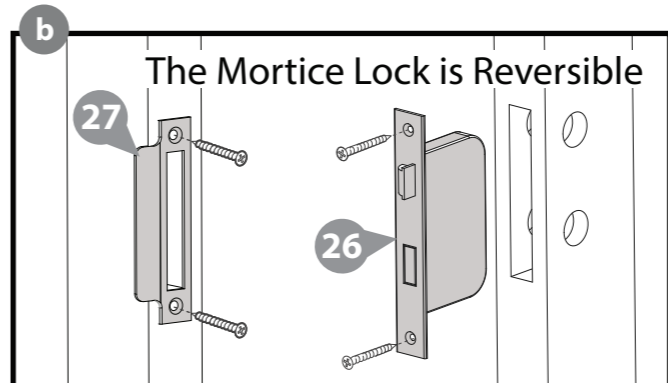
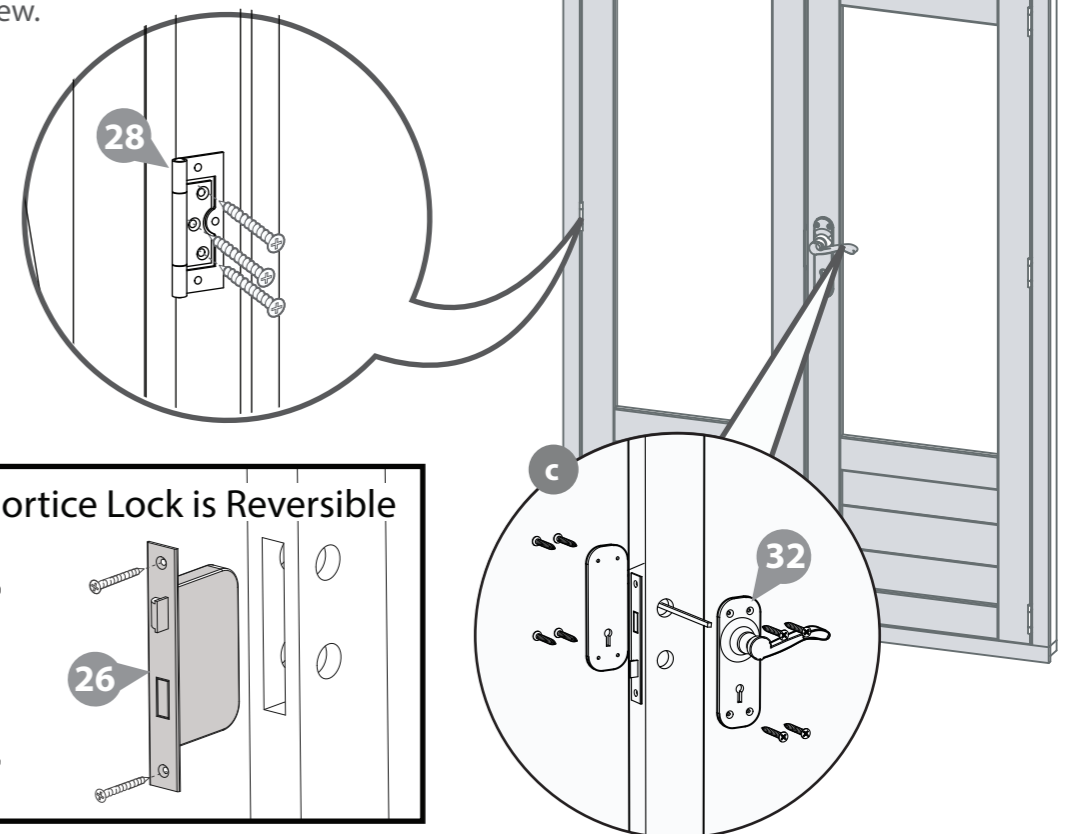
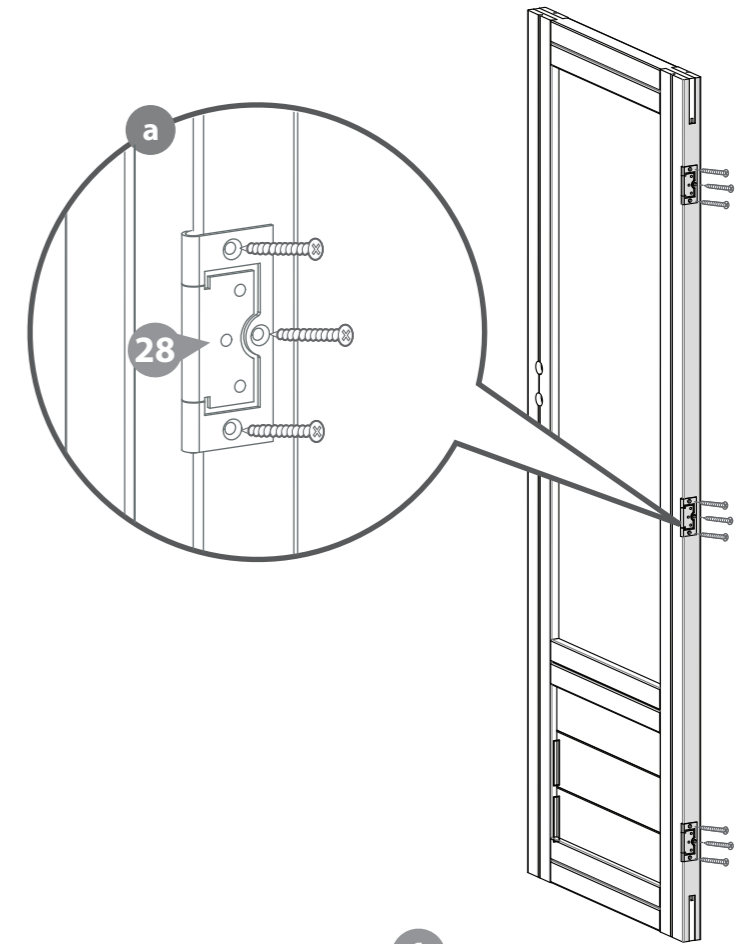



## Step 2

**Parts Needed - No.16 QTY 2**  
**- No.23 QTY 1**  
**- No.30 QTY 2**

**d** Fix the Door Bar (**No. 23**) to the inside of the Secondary Door using 6x30mm screws as shown in the illustration.

Fit the Door Beading (**No. 16**) to the inside of the door frame using 8x30mm screws, ensuring that they sit flush with the frame and the door.

**e** Attach the Tower Bolts (**No. 30**) to the door bar using 12x30mm screws.

**26x30mm screws**

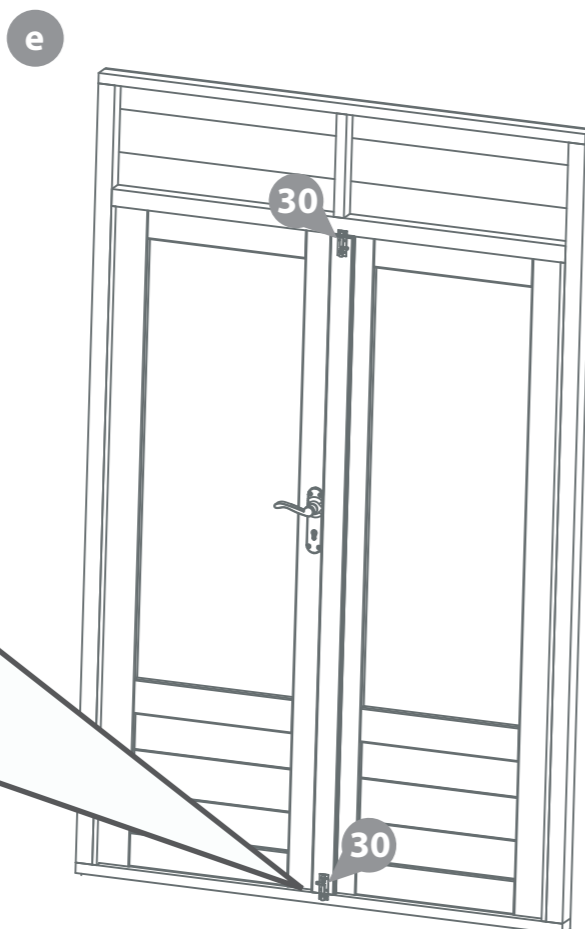
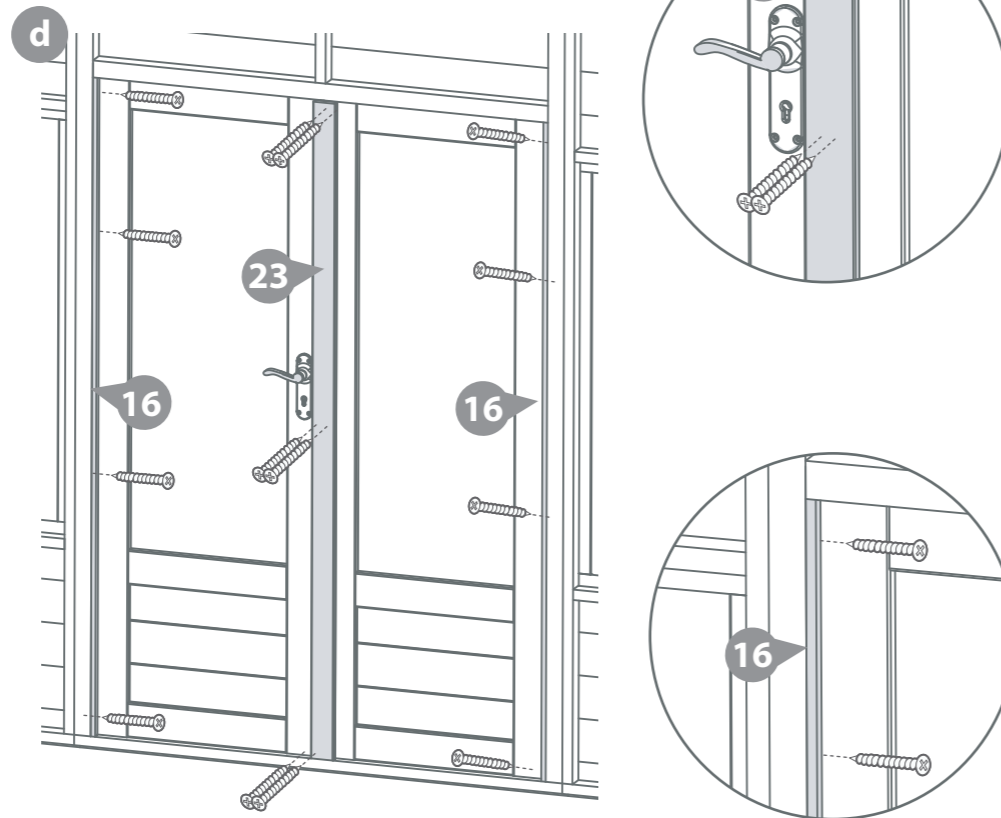

**IMPORTANT: Pre-drill before fixing screws.**

## Step 3

**Parts Needed - No. 8 QTY 2**  
**- No. 24 QTY 8**

Secure the floor (**No. 8**) to the Floor Blocks (**No.24**) using 8x30mm screws per floor.

**Repeat this for one other floor panel**

**16x30mm Screws**



**IMPORTANT: Pre-drill before fixing screws.**

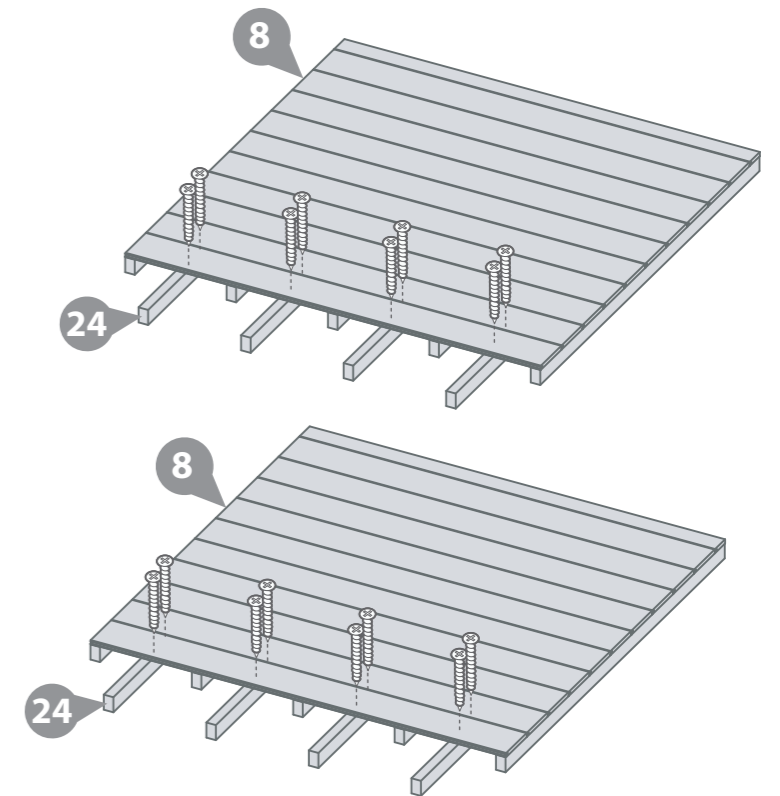

## Step 4

**Parts Needed - No. 8 QTY 2**

Secure the floor (**No. 8**) to the assembly from Step 3, using 8x30mm screws per floor.

**Repeat this to create two assembled floors**

**16x30mm Screws**



**IMPORTANT: Pre-drill before fixing screws.**

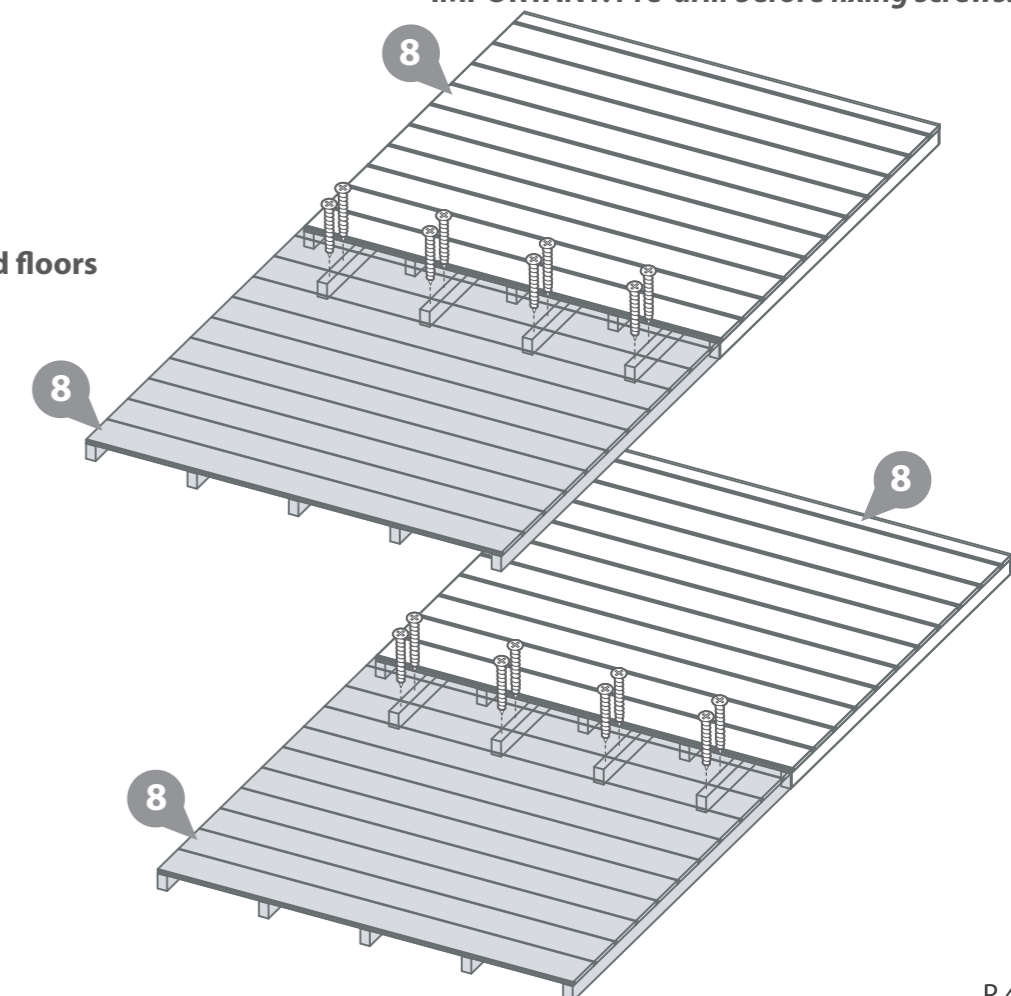

## Step 5

Place the assembled floor panels (**No.8**) on to a firm and level base. Ensure the base has suitable drainage, free from areas where standing water can collect.

Secure the floors together using 8x50mm screws through the floor bearers in an alternating pattern.

### 8x50mm Screws

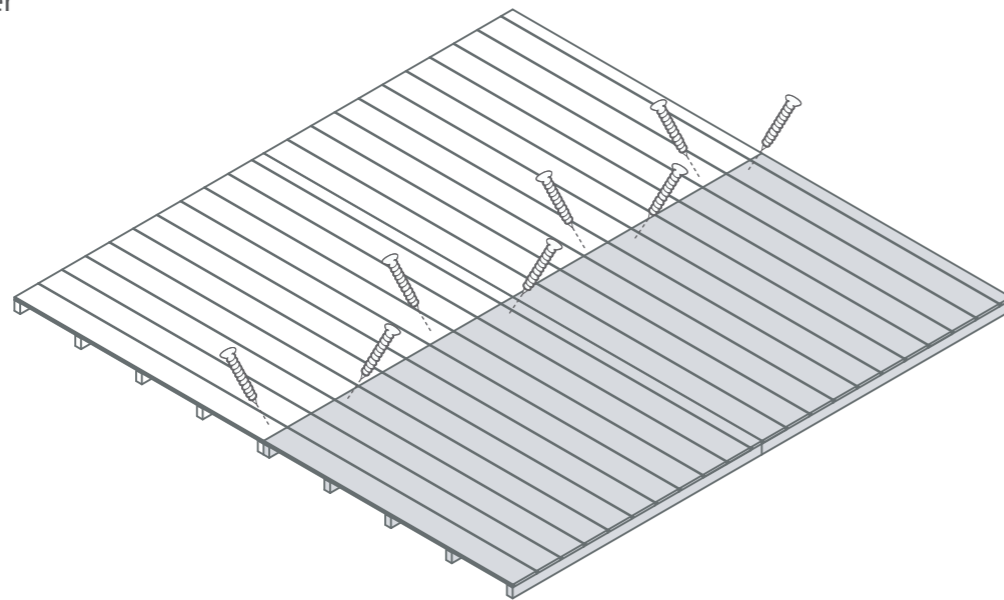

**IMPORTANT: Pre-drill before fixing screws.**

## Step 7

### Parts Needed - No. 5 QTY 1

Place Side Panel (**No. 5**) onto the floor next to the back panel. Fix the two panels together at the corners using 3x50mm screws.

Do **NOT** secure the building to the floor until the roof is fitted.

Position the panels so there is equal spacing between the floor and cladding on all sides.

### 3x50mm Screws

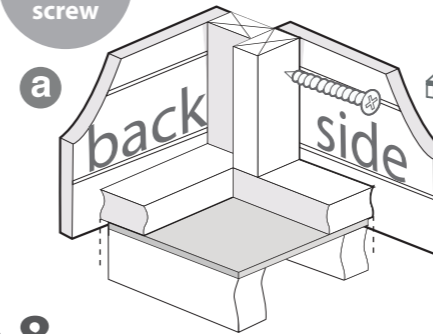

**IMPORTANT: Pre-drill before fixing screws.**

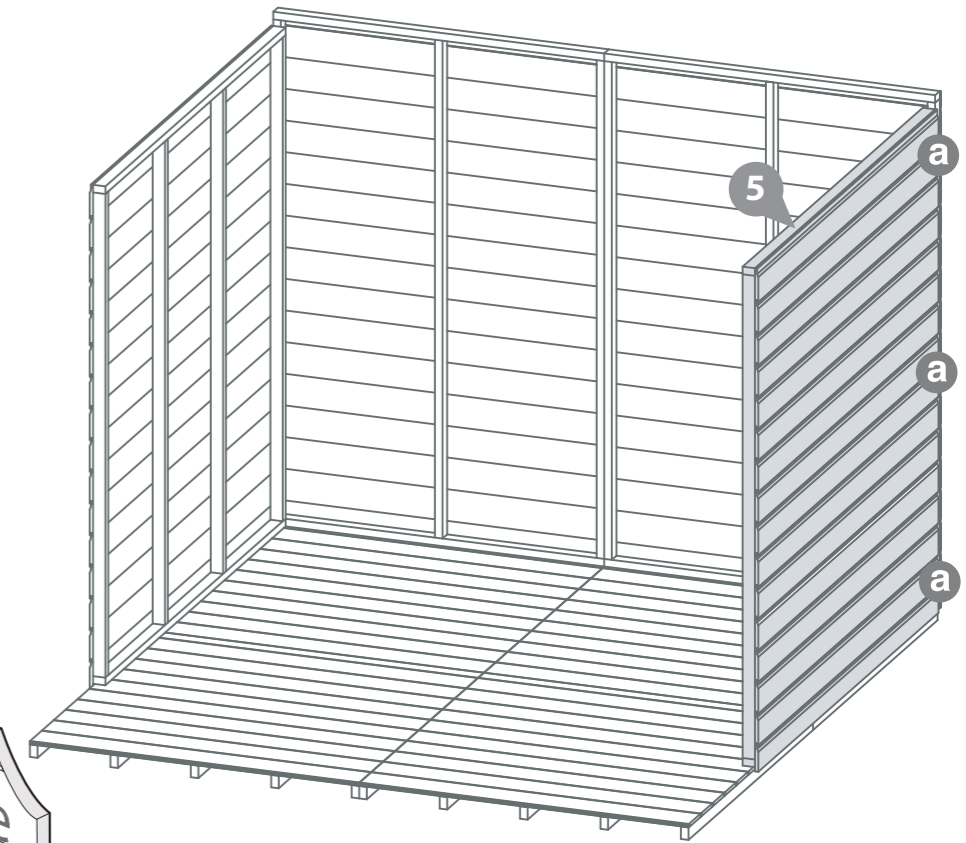

## Step 6

### Parts Needed - No. 4 QTY 2 - No. 5 QTY 1

Fix the Back panels (**No.4**) side by side using 3x50mm screws, fix the corners of the back panel (**No.4**) and the Side Panel (**No.5**)

Do **NOT** secure the building to the floor until the roof is fitted.

Position the panels so there is equal spacing between the floor and cladding on all sides.

### 6x50mm Screws

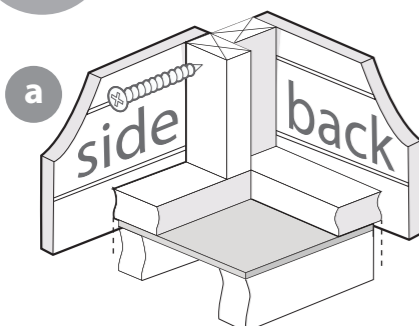

**IMPORTANT: Pre-drill before fixing screws.**

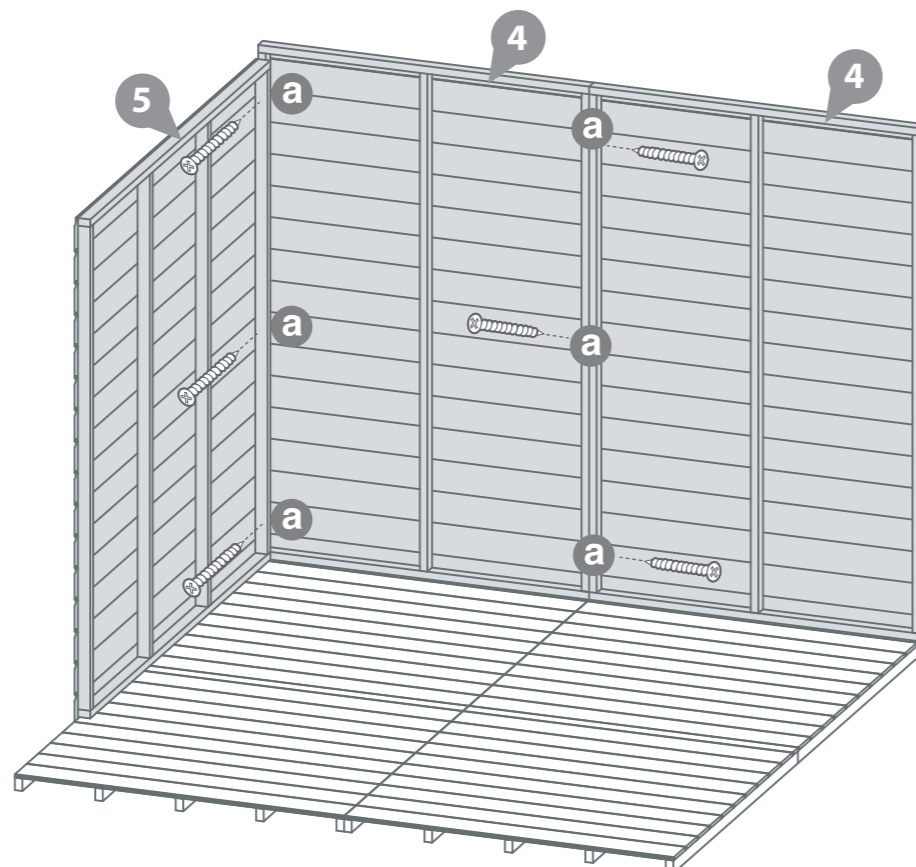

## Step 8

### Parts Needed - No.3 QTY 2

Fix the Side Window Panels (**No.3**) to the already standing Side Panels (**No.5**) by screwing through the framing using 8x50mm screws.

**Ensure to stagger screws to avoid colliding.**

Repeat this with the second Window and Side panel but the opposite way round, as shown in the diagram.

Do **NOT** secure the building to the floor until the roof is fitted.

Position the panels so there is equal spacing between the floor and cladding on all sides.

### 8x50mm Screws



**IMPORTANT: Pre-drill before fixing screws.**

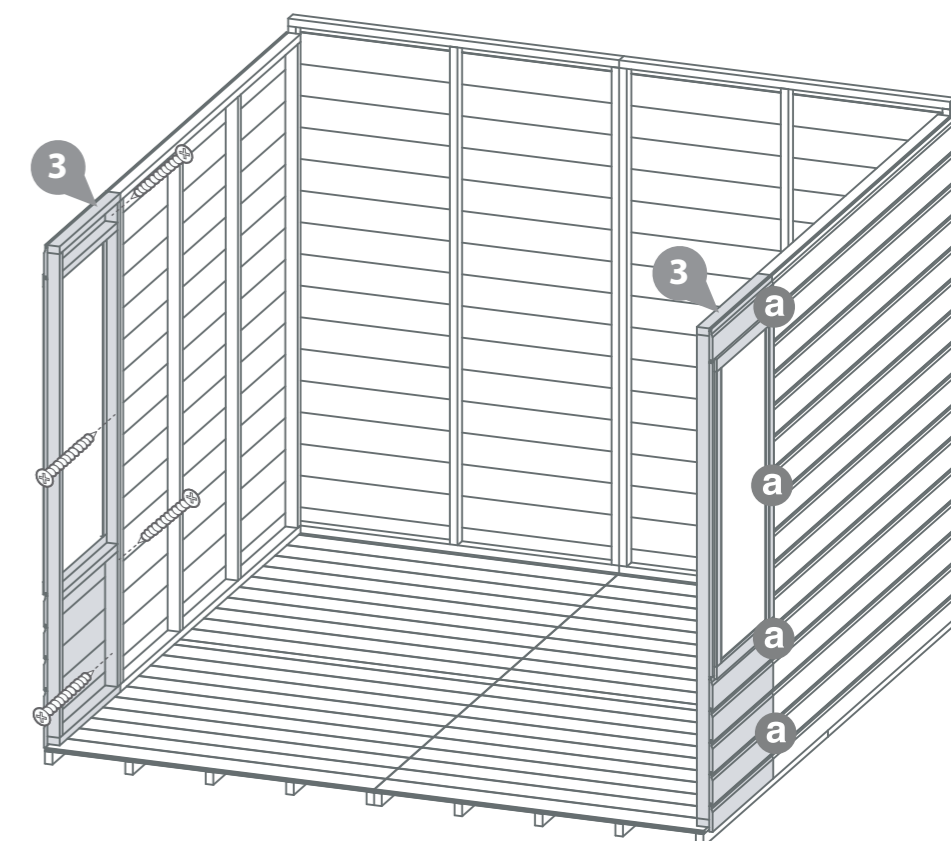



## Step 9

Parts Needed - No. 6 QTY 1  
- No. 7 QTY 1

Place the Left Gable (No.6) and Right Gable (No.7) on top of the side panels, ensuring the boards interlock.

Secure in place using 4x50mm screws per gable top, screwing in an alternating pattern.

### 8x50mm Screws



**IMPORTANT: Pre-drill before fixing screws.**

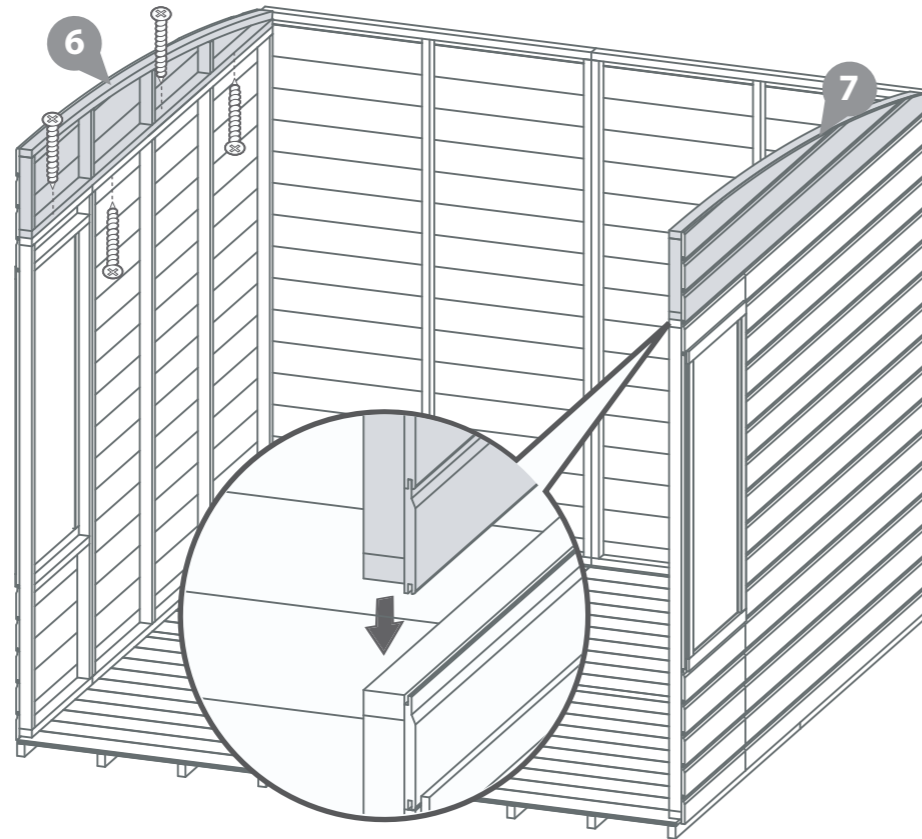

## Step 11

Parts Needed - No.1 QTY 1

Place the assembled door panel (No.1) onto the floor inbetween the already standing Front Window Panels (No.2).

Fix the panels together at the corners using 4x50mm screws per side.

Do **NOT** secure the building to the floor until the roof is fitted.

Position the panels so there is equal spacing between the floor and cladding on all sides.

### 8x50mm Screws



**IMPORTANT: Pre-drill before fixing screws.**

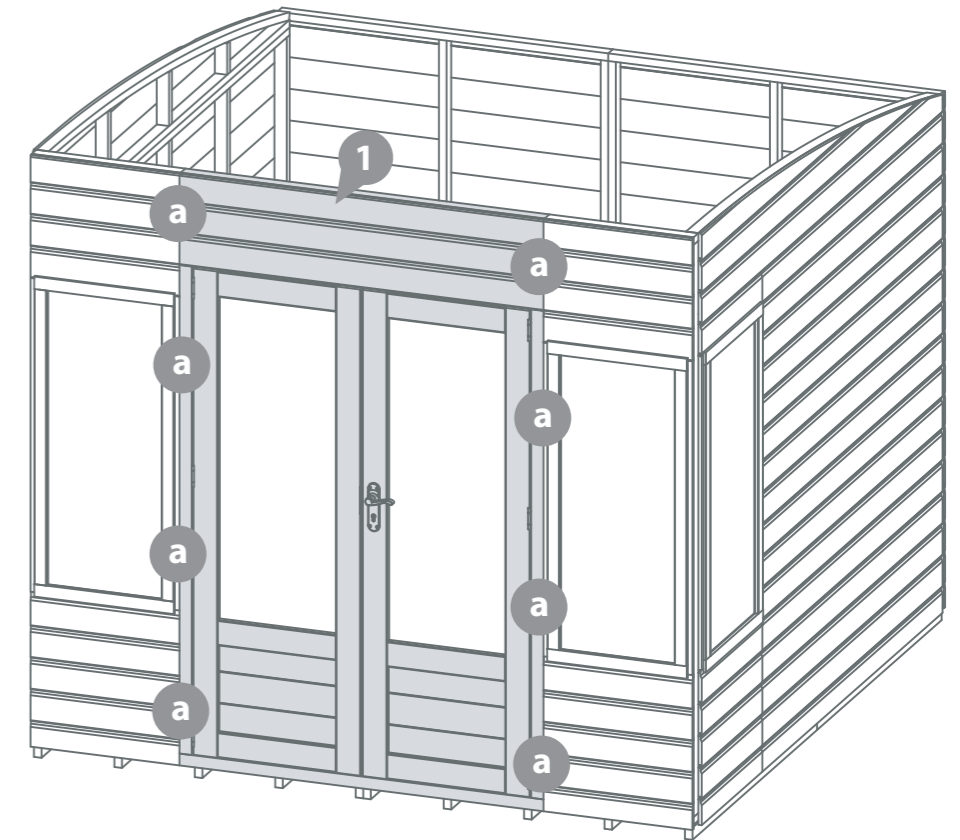

## Step 10

Parts Needed - No.2 QTY 2

Fix the Front Window Panels (No.2) together with the Side Window Panels (No.3) corners with 50mm screws as shown in the illustration.

Do **NOT** secure the building to the floor until the roof is fitted.

Position the panels so there is equal spacing between the floor and cladding on all sides.

### 6x50mm Screws

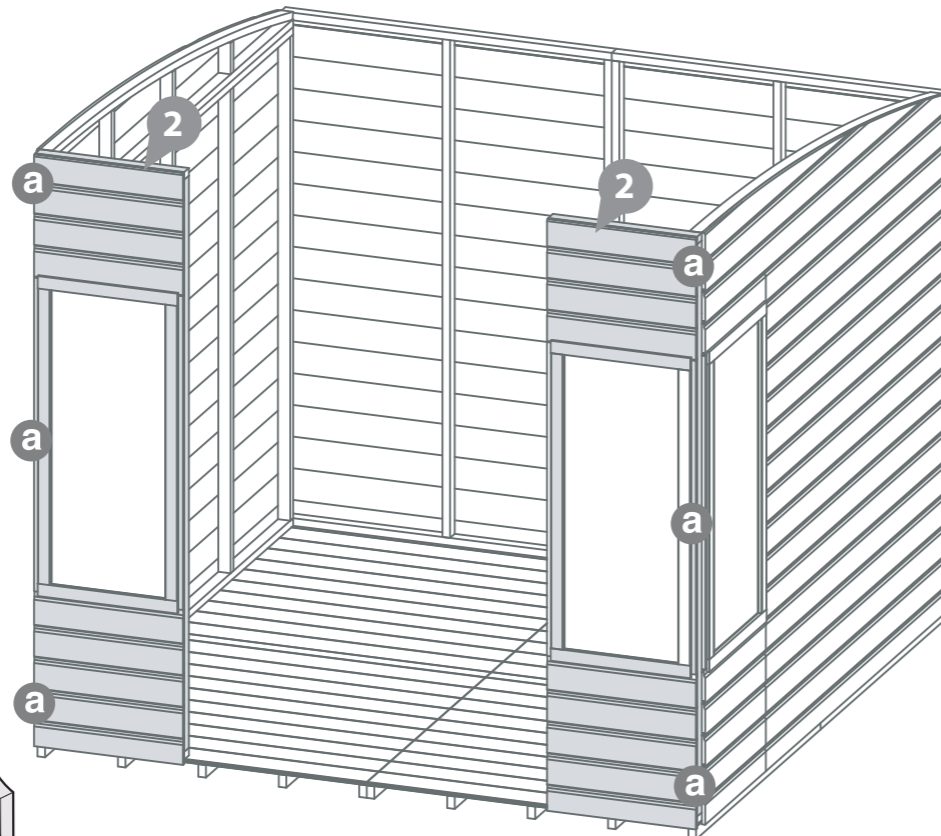
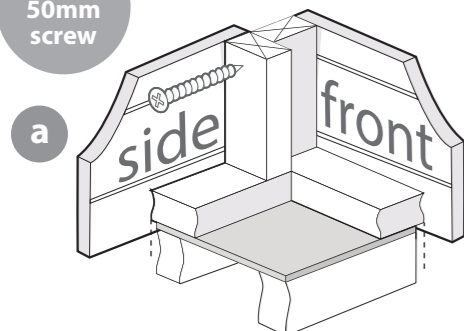

**IMPORTANT: Pre-drill before fixing screws.**

## Step 12

Parts Needed - No.12 QTY 6  
- No.22 QTY 3

**a** Place the first Ridge Bar (No.22) inside the building, centralise it with the vertical gable framing. Align the back edge of the ridge bar with the top of the gable. Once in place mark the position on both sides with a pencil.

Place the top edge of the roof support block (No. 12) flush to the pencil mark and secure in place using 2x50mm screws per block.

\*Repeat this process on both sides with the remaining Ridge Bars.

**b** Place the Ridge Bar(s) on top of the attached blocks and secure through the outside of both gables using 2x80mm screws per side.

12x50mm Screws  
12x80mm Screws



**\*Hint: When fitting the Ridge Bar pencil mark the centre of the Ridge Bar and follow down onto the gable at a right angle, this will give you a guide to fix the support bars in place.**

**IMPORTANT: Pre-drill before fixing screws.**

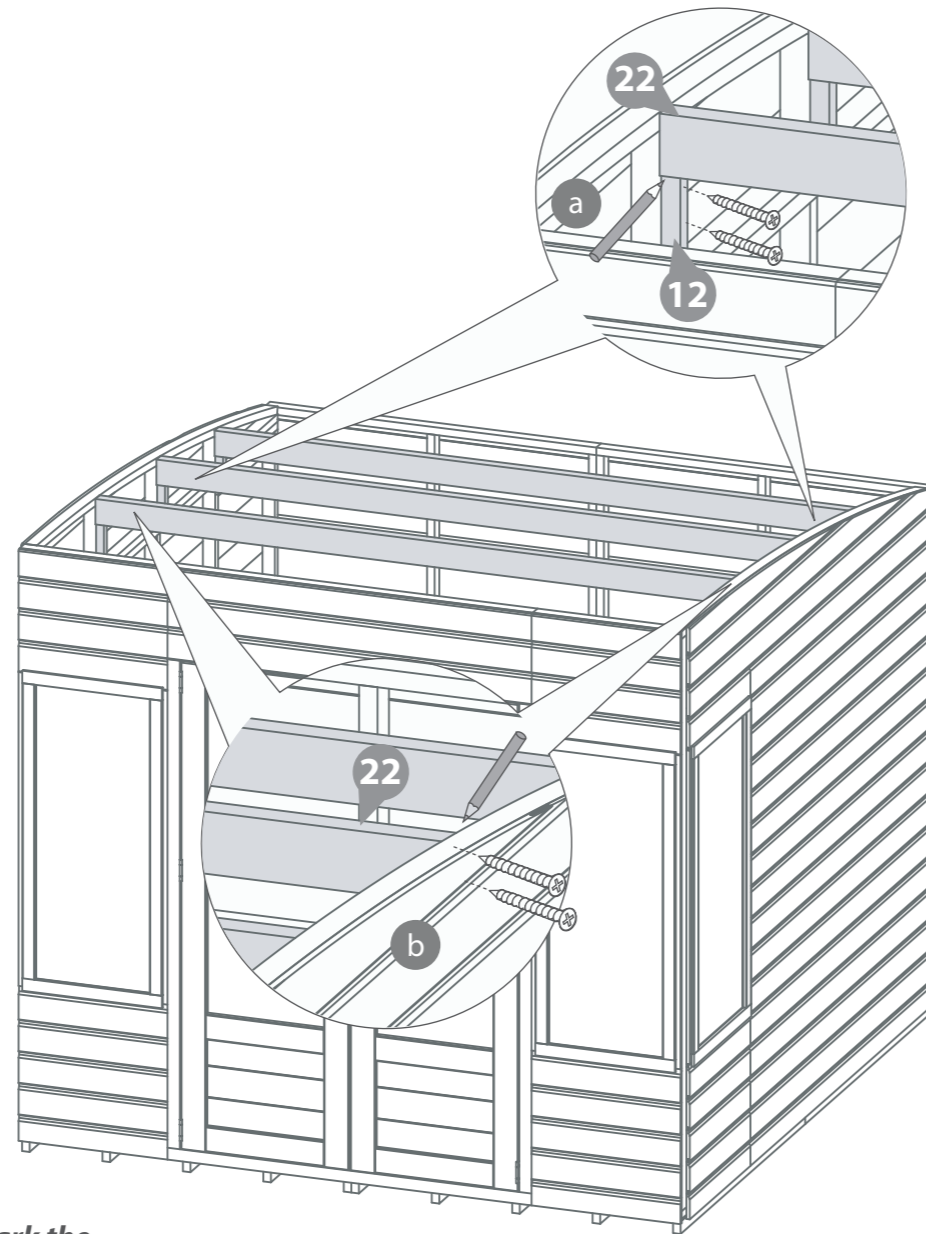

## Step 13

Parts Needed - No. 9 QTY 3  
- No. 25 QTY 3

Place the three roofs (No.9) together. Please note that one of the Roof Panels MUST go the opposite way to the other two Roof Panels. Then slot the three Roof End (No.25) pieces on to the Roof Panels where shown in the diagram. Fix the Roof Ends (No.25) to the top and bottom Framing within the Roof Panels using 2x30mm per end.

12x30mm Screws

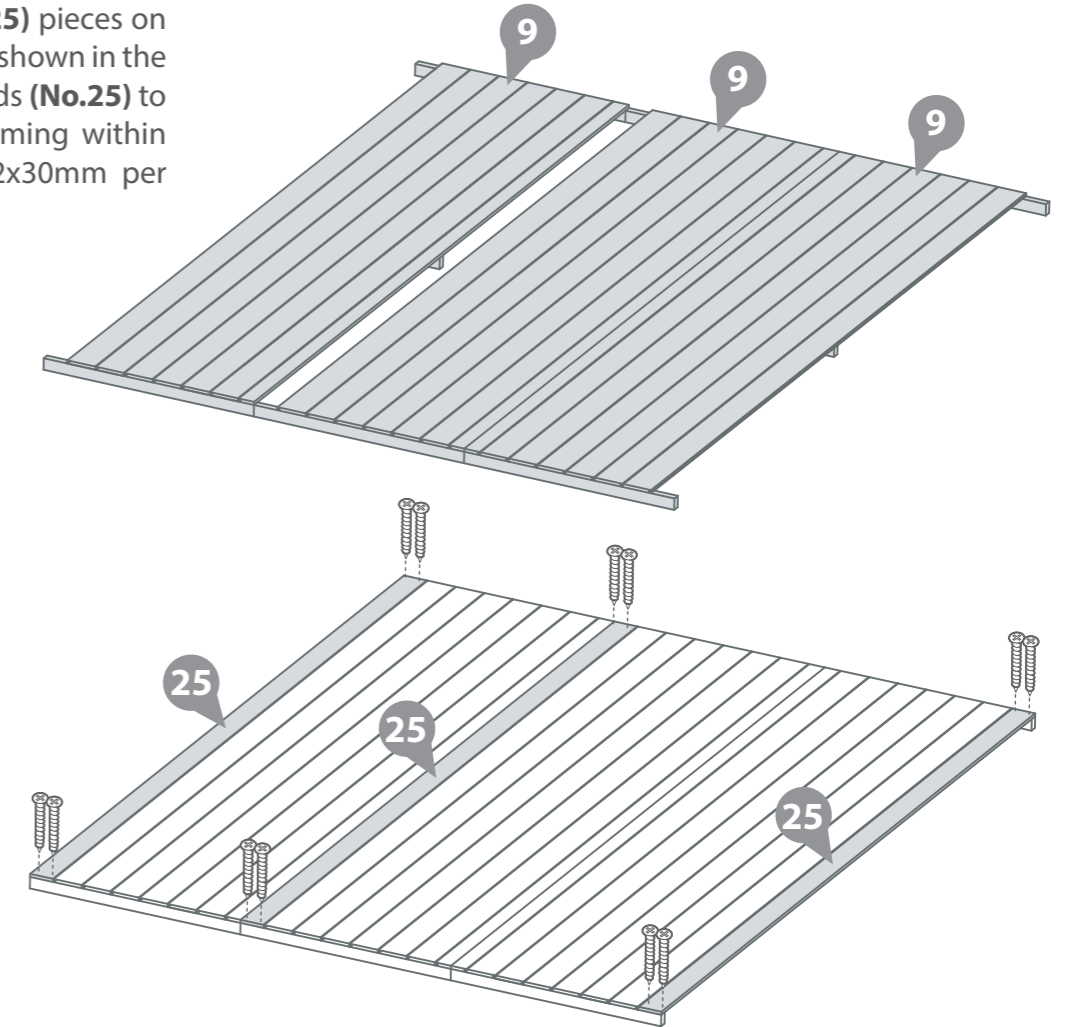

## Step 14

Parts Needed - No.9 QTY 3  
- No.33 QTY 2

**a** Place the Roof Panels (No. 9) on top of the Building. Join together the centre framing on the underside of the roofs by using the two U Channels (No.33) as shown in the diagram. Please note that there will be a space between the framing within one of the U Channels.

**b** Place the centre framing within the Roof Panels (No. 9) in front of the middle Ridge Bar and secure together with 9x50mm screws as shown in the diagram. Ensure the screws line up with the roof support bars.

16x30mm Screws  
9x50mm Screws

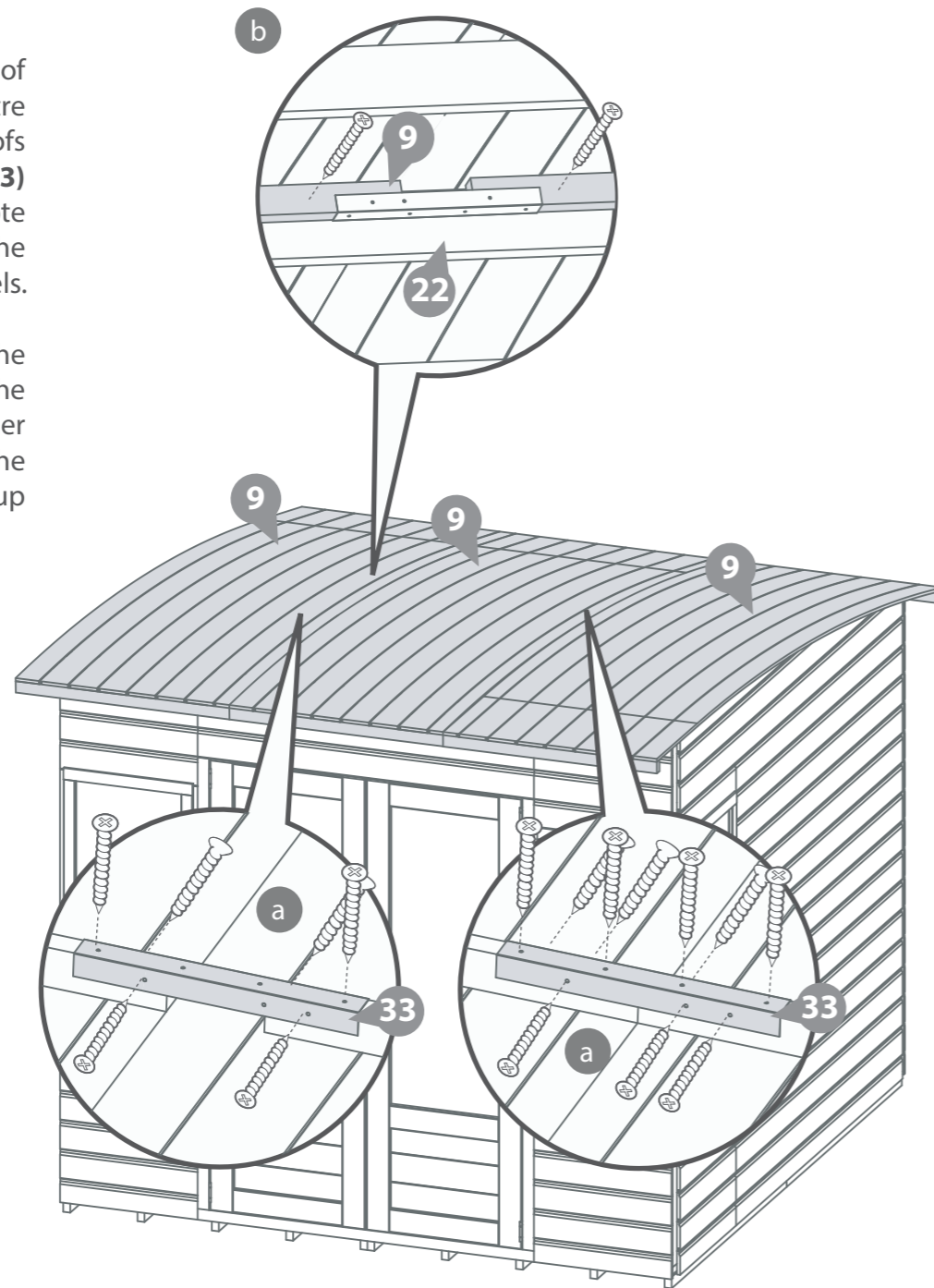
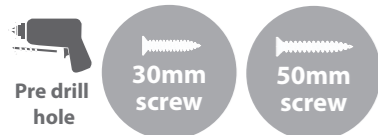

**IMPORTANT: Pre-drill before fixing screws.**

## Step 15

Fix the Roof Panels to the Framing within the Panels and the Ridge Bars where they meet (internally) using 9x30mm screws per line.

**HINT** - Follow the nailing line of the framing on the roof panel so that you are more likely to fix into the ridge bar below. Also use a straight piece of timber as a guide to help keep the screw positions in a straight line.

45x30mm Screws

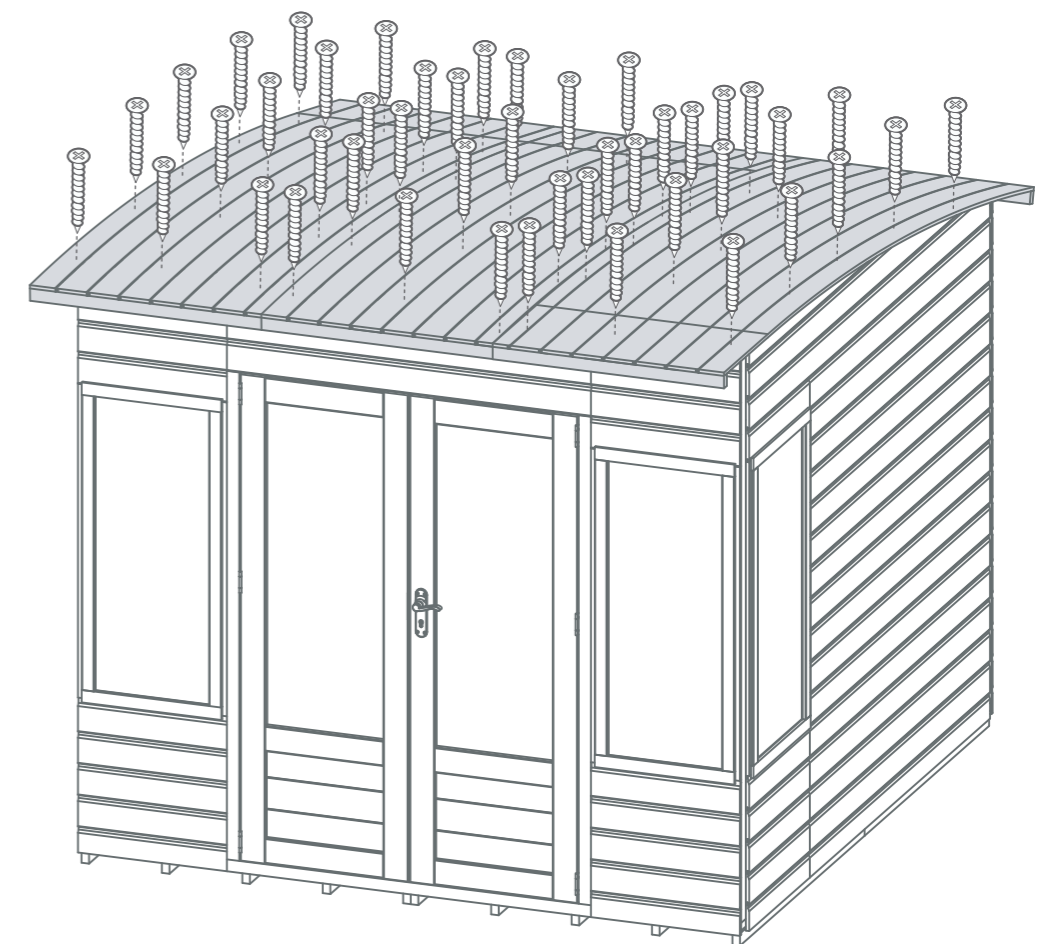

**IMPORTANT: Pre-drill before fixing screws.**



## Step 16

**IMPORTANT: Pre-drill before fixing screws.**

Once the roof is fixed, attach the building to the floor with 50mm screws.

Ensure the screws go through the panel into the floor framing.

**23x50mm Screws**

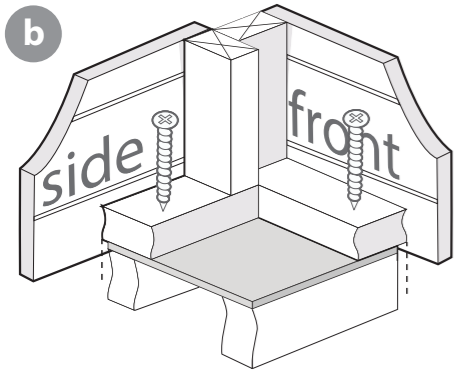
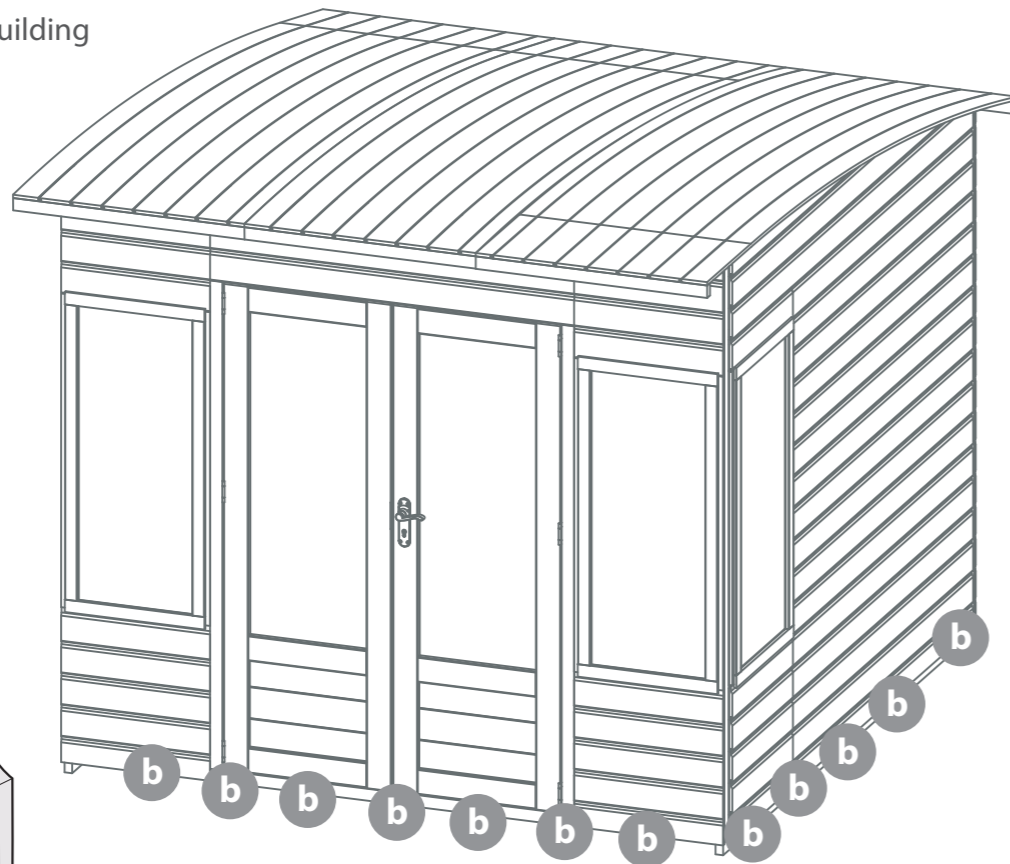
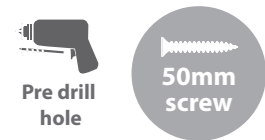

## Step 17

**Parts Needed - No.34 QTY 1**

Cut the felt (**No.34**) into 4x strips measuring: **2580mm (L) X 1000mm (W)** and lay onto the roof in the order shown in the illustration, leaving approximately 50mm of overhanging felt around the building.

Secure the felt to the building with 160x felt tacks at 100mm intervals

**160x Felt Tacks**

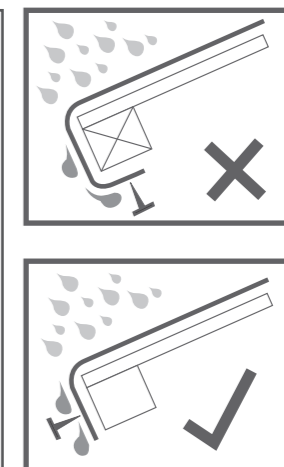
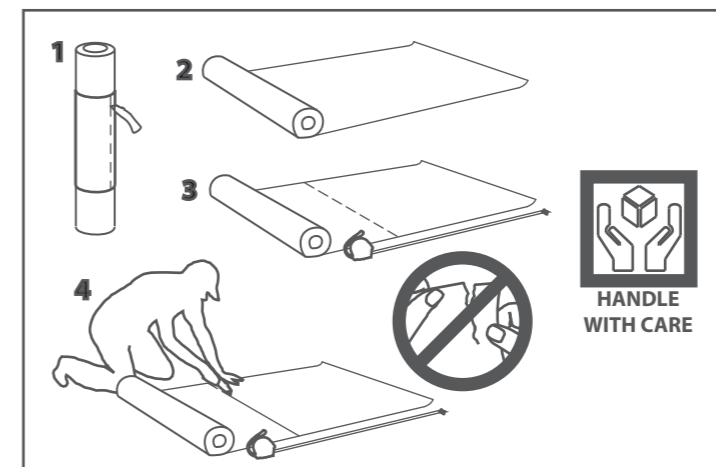
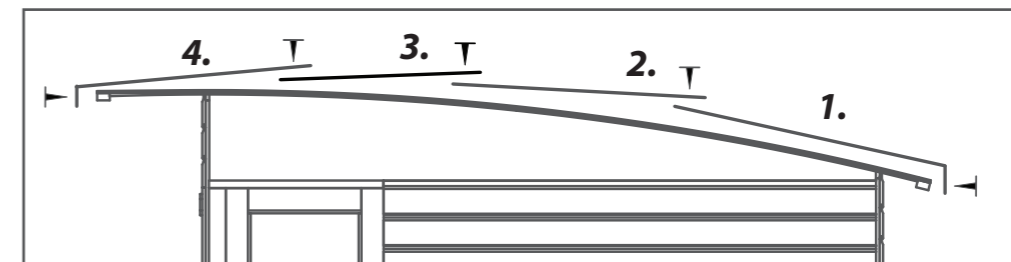
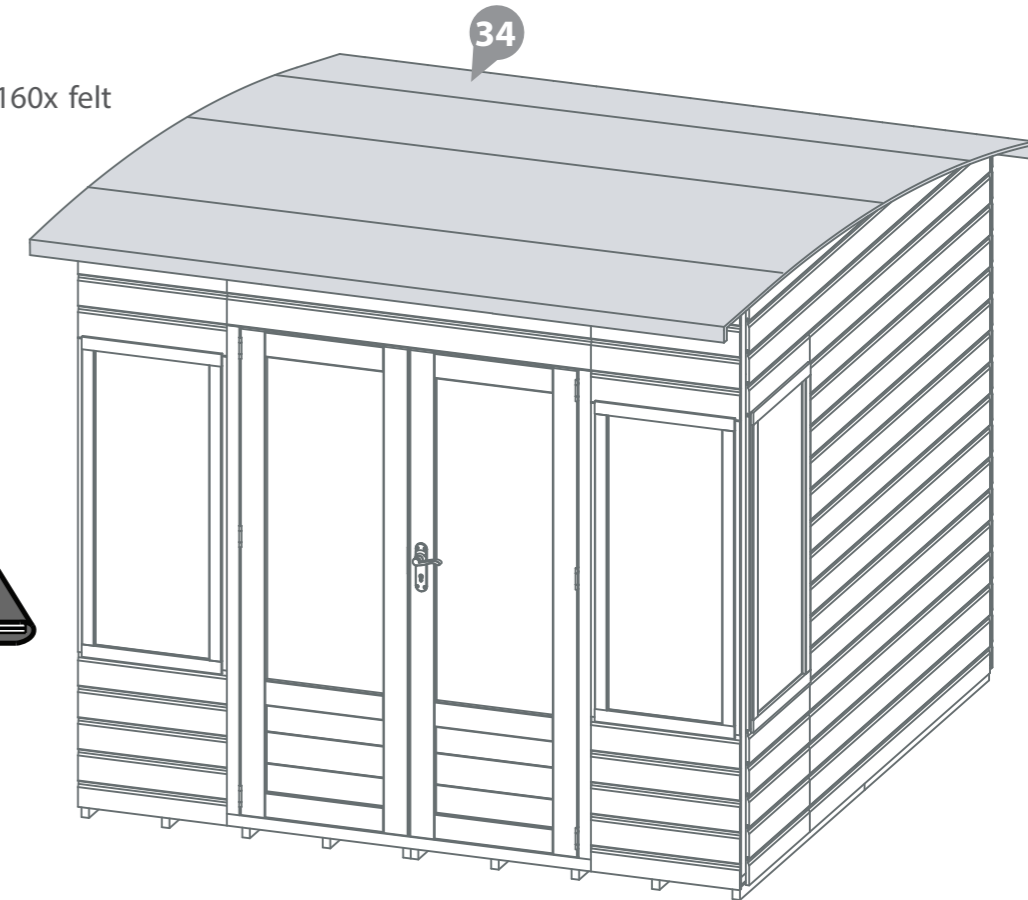
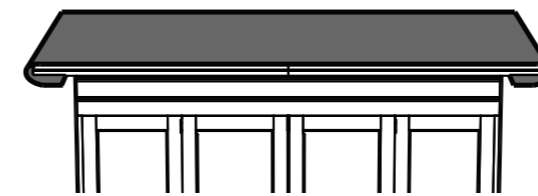

**IMPORTANT: Pre-drill before fixing screws.**

**IMPORTANT: Pre-drill before fixing screws.**

## Step 18

Parts Needed - No.17 QTY 8

Sandwich the felt either side between the roof and the roof trims (No. 17), fixing each strip to the roof with 3x30mm screws. The roof trims will need to be cut to fit.

24x30mm Screws

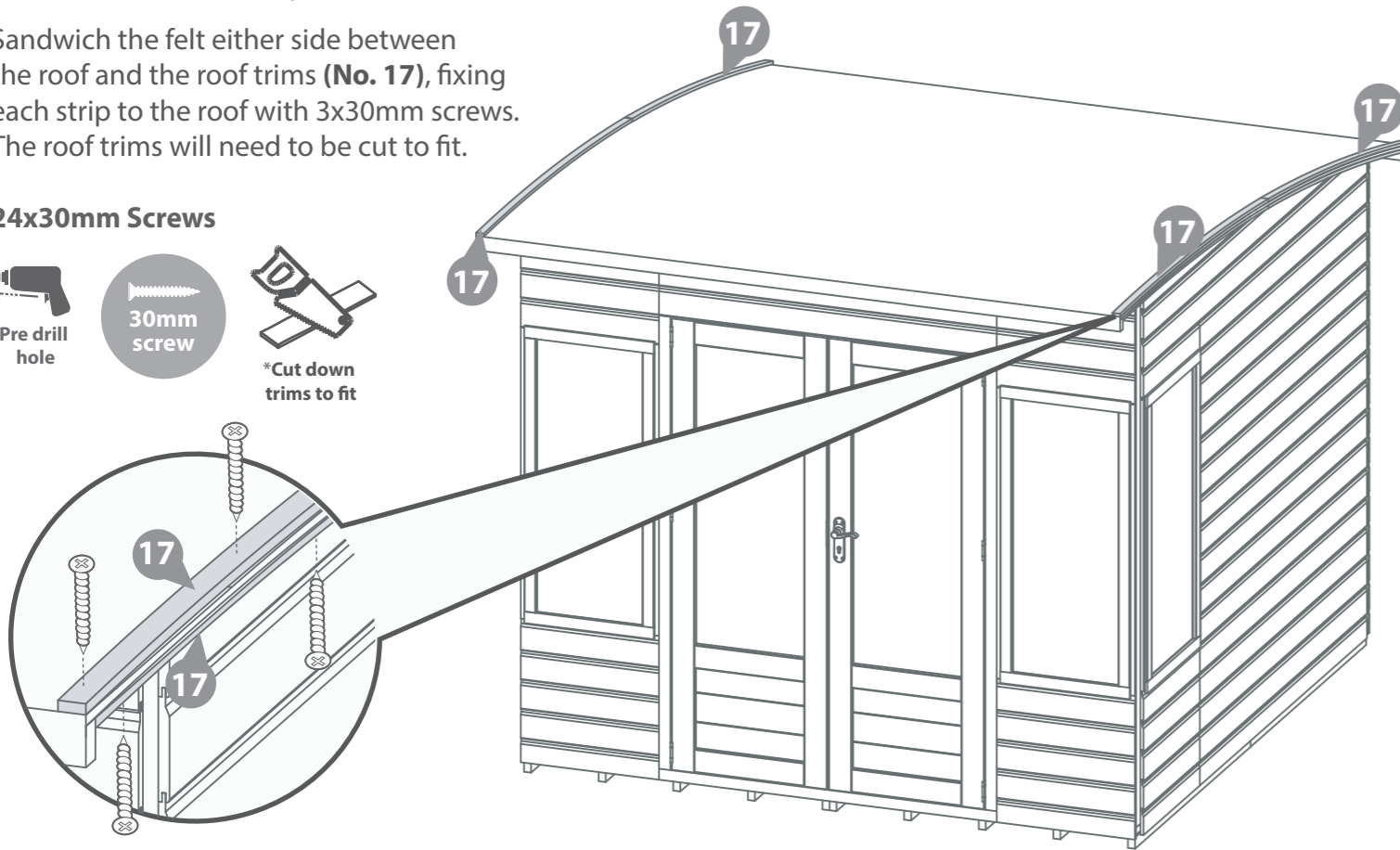
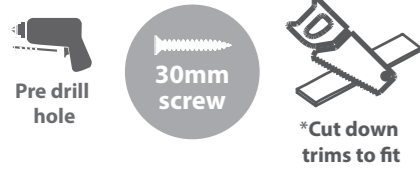

## Step 19

Parts Needed - No. 18 QTY 2  
- No. 31 QTY 1

Fix the fascia's (No. 18) to the front of the building using 4x40mm screws.

Attach the finial (No. 31) over the join in the fascia's with 2x40mm screws.

10x40mm Screws

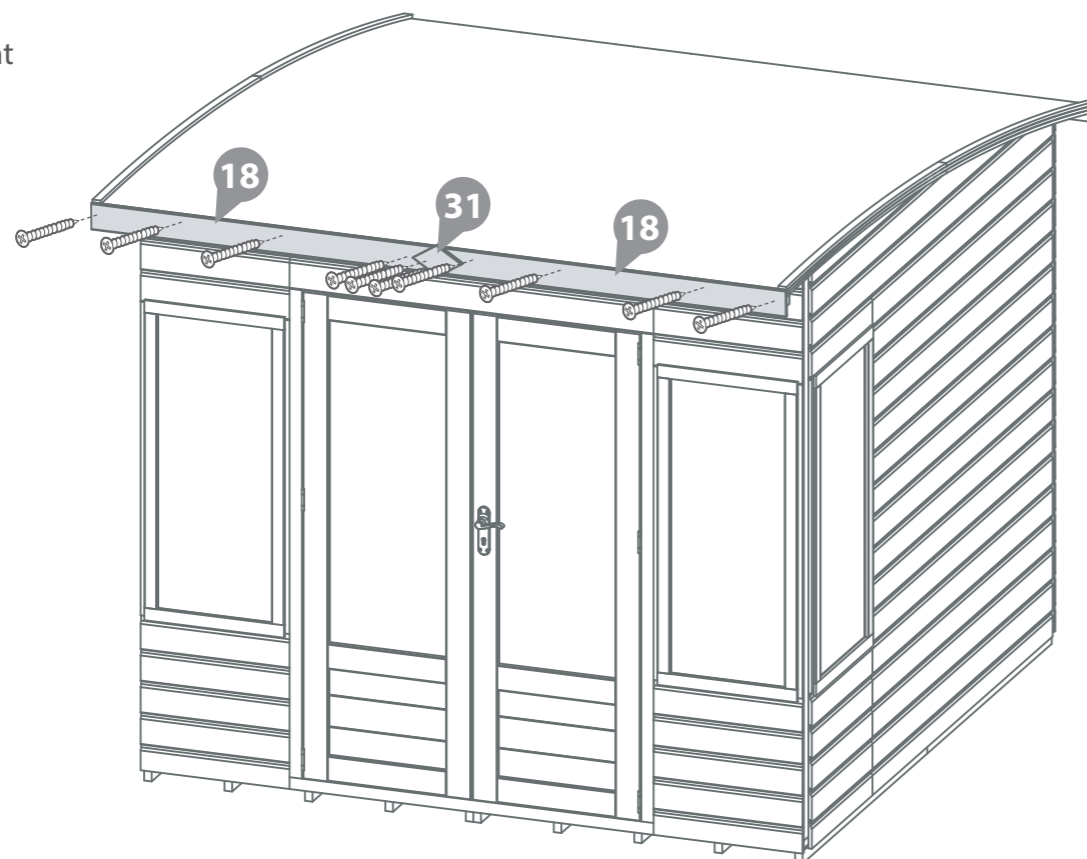

**IMPORTANT: Pre-drill before fixing screws.**

## Step 20

Parts Needed - No. 19 QTY 4  
- No. 20 QTY 2  
- No. 21 QTY 3

Attach the front (No.19), side (No.20) and rear (No.21) cover trims to the building, fixing each trim using 3x30mm screws.

Ensure a trim is fitted to each corner of the building and over panel joins.

30x30mm Screws

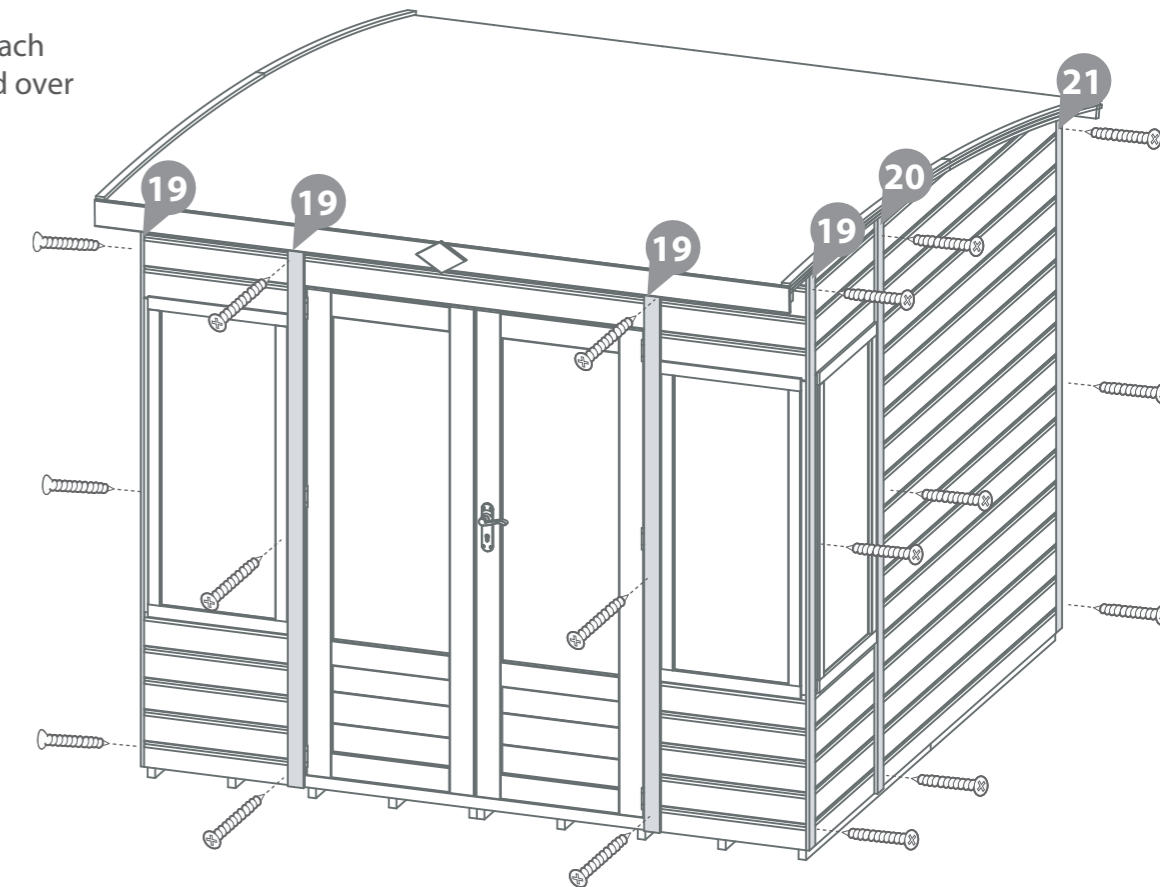
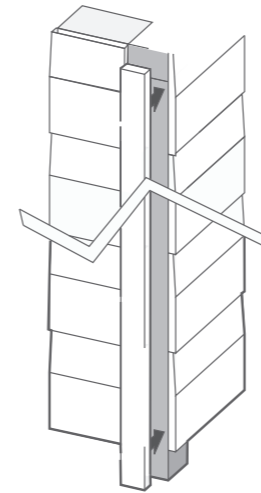

## Step 21

- Parts Needed - No. 13 QTY 1  
 - No. 14 QTY 2  
 - No. 15 QTY 2

Fix the Large Rain Guard (No. 13) above the door using 4x50mm screws.

Attach the Front Window Rain Guards (No.15) and Side Window Rain Guards (No.14) above each relevant window using 3x50mm screws per Rain Guard.

### 16x50mm Screws

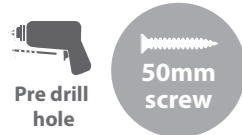

*\*Seal each rain guard with silicone sealant before fixing to the building.*

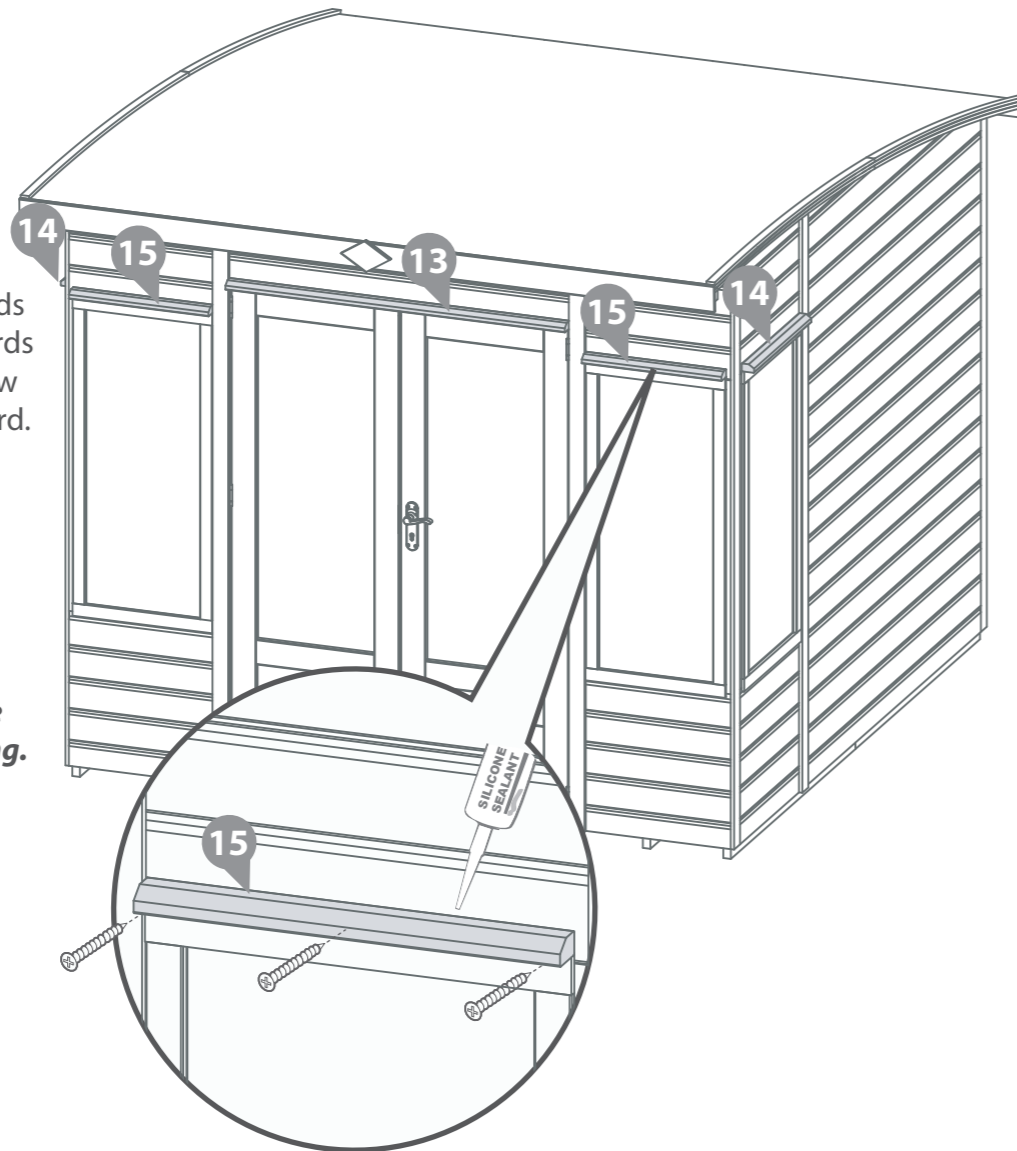

**IMPORTANT: Pre-drill before fixing screws.**

## Step 22

- Parts Needed - No. 29 QTY 2

Fix the turn button's (No. 29) to the top and bottom of the Secondary Door using 2x30mm screws.

### 2x30mm Screws

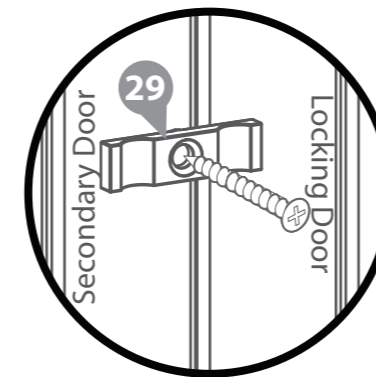

**IMPORTANT: Pre-drill before fixing screws.**

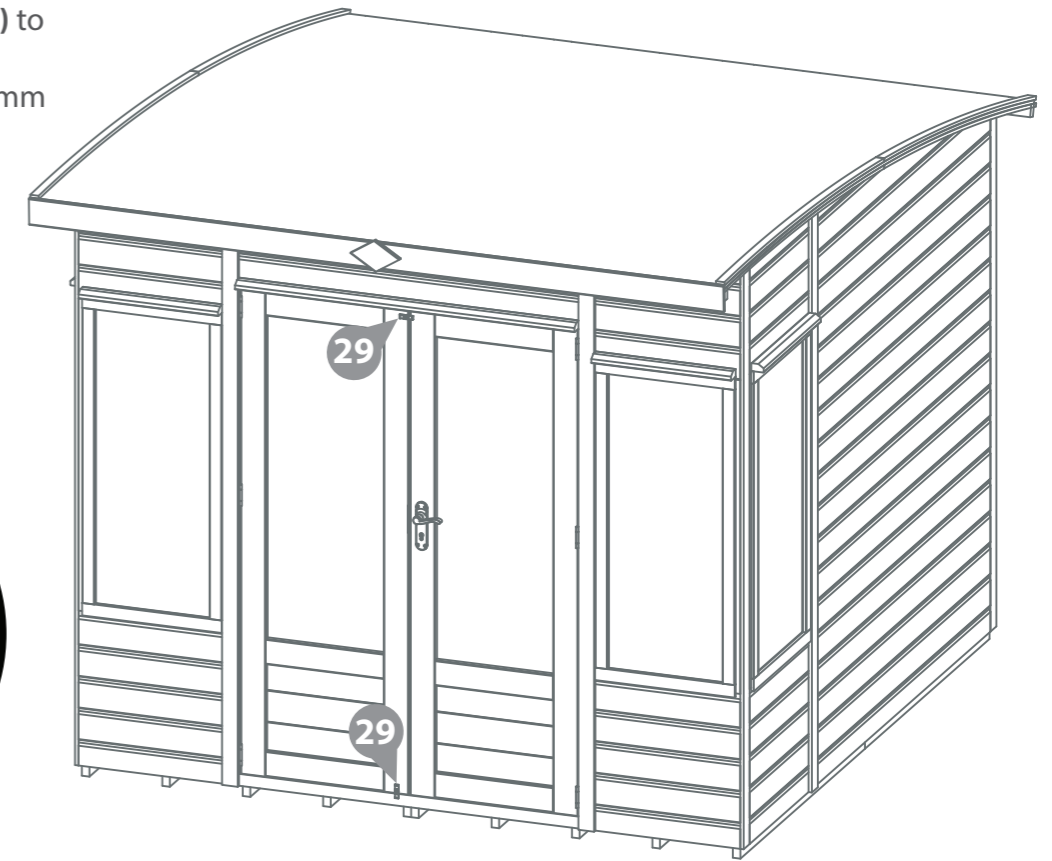

*\*These turn buttons help keep your doors straight during high and low levels of moisture content in the air.*



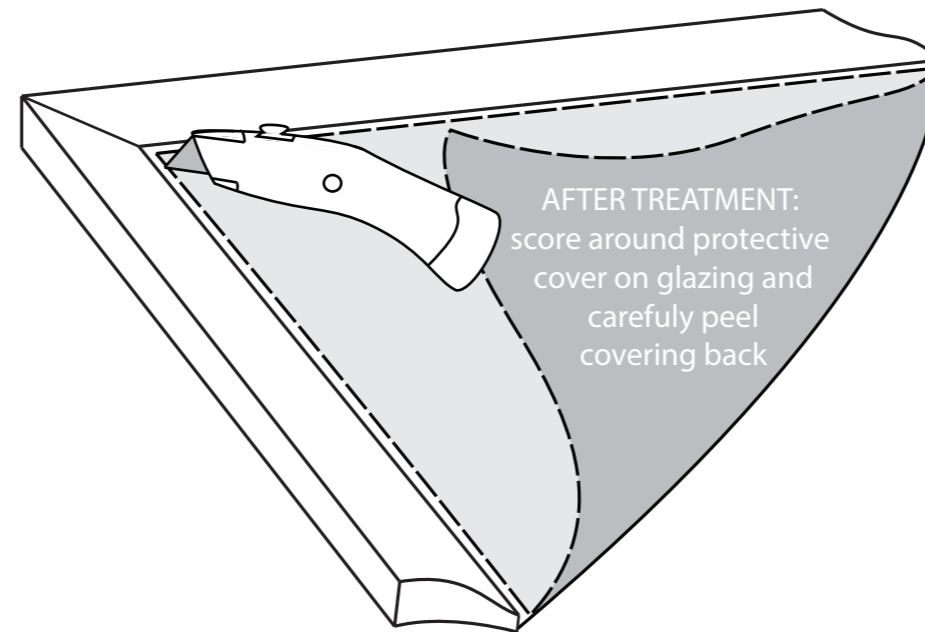

# MANUFACTURER'S RECOMMENDATIONS

All our garden buildings have been designed and manufactured with care and attention to be the perfect addition to your outdoor space. To ensure you do get the best out of your new garden building and to increase the longevity we advise that you follow the product instructions and our manufacturer's recommendations as detailed below. Thank you for choosing a Mercia Garden product!

## 1 Choosing the most suitable location for your garden building...

A minimum of 60cm should be left around the perimeter of your garden building to allow access for maintenance, annual treatment and to allow air flow around the building.

Where possible you should avoid placing your garden building underneath large trees to prevent the tree causing damage to the building.

## 2 Preparing the base for your garden building...

All our buildings must be built on a firm, level base to ensure the longevity of the building and prevent the wood from distorting. We recommend either concrete, concrete slabs or a wooden base, such as our 'Portabase'.

The base should be slightly smaller than the external measurement of the building, i.e. the cladding should overlap the base, creating a run off for water and preventing water from pooling underneath the building.

We also recommend that the floor of the garden building is a minimum of 25mm above the surrounding ground level to avoid flooding.

## 3 After installation...

Once your garden building has been installed it will need to be treated as soon as possible and annually to prevent the timber from deteriorating and to waterproof it. This is required to maintain the anti-rot guarantee.

Dip Treated buildings - Require a preservative treatment to protect against rot and decay and a waterproof treatment to prevent water ingress

Pressure Treated buildings - Require a waterproof treatment to prevent water ingress

Log Cabins/Insulated Garden Rooms - Are supplied untreated and require a preservative and waterproofing treatment

We also recommend using a silicon sealant on the inside and outside of the windows as soon as possible after assembly and treatment to fully seal the windows.

Roofing felt/covering should be checked annually and replaced or fixed accordingly.

## 4 General maintenance and wood characteristics

As wood is a natural material it may be affected by the following:

**Shrinkage and warping** - The timber used in the construction of your garden building will have retained some of its natural moisture content. The moisture content of the timber will vary, depending upon prevailing environmental conditions, which will result in the components either naturally expanding or contracting. As the components dry out shrinkage may occur. A good waterproofing treatment from the start is the best protection to minimise the effect of moisture loss/intake.

In extended periods of very warm weather getting some moisture to the building will help the overall balance. You can do this by spraying it down lightly with a garden hose. In contrast after snow fall try to remove the snow as best as possible from the roof to prevent moisture intake and to remove the extra weight.

Top tip - using a garden brush will help you to reach the highest part of the building to remove snow and any debris left from bad weather.

**Damp and mould** - During the winter months, cold and damp conditions can result in an increased amount of moisture within your garden building, especially when used infrequently. Condensation can form on the timber and other items stored within your garden building. If left this moisture is likely to cause mould and mildew. To prevent the build-up of moisture, we recommend leaving the door or windows of your building open from time to time, to allow the fresh air to circulate. We also advise against storing wet or damp items in your garden building as this will also increase the level of moisture in the building. If mould or mildew does start to form within your building we recommend using an anti-mould cleaner to remove it and to prevent it spreading, which if left untreated could permanently damage your garden building.

**Splits, cracks and knots** - You may notice small splits and cracks in some components or holes may appear where knots shrink and fall out. This will not affect the structure of your Garden building however if you wish to fill them this can be easily done using any good quality wood filler.

**Sap** - is naturally occurring in wood and may appear in some boards of your garden building. If you wish to remove the sap, we advise waiting until it is dry and then using a sharp knife to carefully remove it. If the removal of the sap causes a hole in the timber, we recommend using a good quality wood filler to fill it.

For more handy hints and tips on how to care and maintain your garden building please refer to the MGP Customer Portal at [www.mgplogistics.co.uk](http://www.mgplogistics.co.uk)

Any further questions?

Contact our  
Customer Service  
Team on:  
01636 821215

# WARRANTY AND GUARANTEE

## 1 Manufacturer's Warranty

All Mercia Garden Products are supplied with a 1 year warranty on all parts against manufacturing defects.

This warranty does not cover movement, warping or splitting of timber products over time.

This warranty will be voided if any of the following occur:

1. The building has been customised or modified/adapted in any way.
2. The person claiming is not the original purchaser of the building.
3. Any damage has been caused by or as a result of misuse.
4. The building has not been maintained and cared for in accordance to our advisories and manufacturer's recommendations.
5. The building has not been treated annually or as per the manufacturer's recommendations, please ensure receipts are kept to validate this claim.
6. The building has not been erected, fitted or installed as per the supplier instructions.
7. The building has not been erected on a suitable sized firm flat, solid level concrete/slab base or placed on pressure treated bearers.
8. The building is or has been placed with 2 feet (60cm) of any obstructions (walls, trees, plants, fences etc.) which can allow moisture to penetrate the timber.
9. The roofing felt has been incorrectly fitted or damaged allowing water ingress, or not properly maintained.
10. Any windows and joints have not been sealed, inside and out, with silicone or other watertight sealant.
11. Any timber has been cut, pierced or drilled without subsequent application of approved cut-end treatment.



REGISTER FOR YOUR  
**ANTI-ROT**  
GUARANTEE TODAY

PLEASE SCAN HERE:



## 2 Anti-rot Guarantee

Mercia Garden Products offer a 10 year anti-rot guarantee on all dip treated (a preparatory treatment) and 15 years on all pressure treated products. This guarantee covers solid timber against rot, decay, blue stain and insect attack.

To validate the guarantee the building must be treated with a recognised wood preserver/water proof top coat (as detailed within manufacturer's recommendations) as soon as possible after assembly and annually thereafter.

This guarantee does not cover movement, warping or splitting of timber products over time.

This guarantee will be voided if any of the following occur:

1. The building has been customised or modified/adapted in any way.
2. The person claiming is not the original purchaser of the building.
3. Any damage is caused by or as a result of misuse.
4. The building has not been maintained and cared for in accordance to our advisories and manufacturer's recommendations.
5. The building has not been treated annually or as per the manufacturer's recommendations, please ensure receipts are kept to validate this claim.
6. The building has not been erected, fitted or installed as per the supplier instructions.
7. The building has not been erected on a suitable sized firm flat, solid level concrete/slab base or placed on pressure treated bearers.
8. The building is or has been placed with 2 feet (60cm) of any obstructions (walls, trees, plants, fences etc.) which can allow moisture to penetrate the timber.
9. The roofing felt has been incorrectly fitted or damaged allowing water ingress, or not properly maintained.
10. Any windows and joints have not been sealed, inside and out, with silicone or other watertight sealant.
11. Any timber has been cut, pierced or drilled without subsequent application of approved cut-end treatment.