

General Instructions

Please retain product label and instructions for future reference

03DTSHHP1206HGD4MW-V1 & 03DTMBHP1206RFP

12x6 Clover Summerhouse

BEFORE YOU START PLEASE READ INSTRUCTIONS CAREFULLY

- Check the pack and make sure you have all the parts listed.
- When you are ready to start, make sure you have the right tools at hand (not supplied) including a Phillips screwdriver, Stanley knife, Wood saw, Step ladder, Hammer and a Drill with 2mm bit.
- Ensure there is plenty of space and a clean dry area for assembly.

LOCATION FOR YOUR GARDEN BUILDING

A minimum of 60cm should be left around the perimeter of your garden building to allow access for maintenance, annual treatment and to allow air flow around the building.

Where possible you should avoid placing your garden building underneath large trees to prevent the tree causing damage to the building.

TIMBER

As with all natural materials, timber can be affected during various weather conditions. For the duration of heavy or extended periods of rain, swelling of the wood panels may occur. Warping of the wood may also occur during excessive dry spells due to an interior moisture loss. Unfortunately, these processes cannot be avoided but can be helped. It is suggested that the outdoor building is sprayed with water during extended periods of warm sunshine and sheltered as much as possible during rain or snow.

Once your garden building has been installed it will need to be treated as soon as possible and annually to prevent the timber from deteriorating and to waterproof it. This is required to maintain the anti-rot guarantee.

Dip Treated buildings - Require a preservative treatment to protect against rot and decay and a waterproof treatment to prevent water ingress

Pressure Treated buildings - Require a waterproof treatment to prevent water ingress

Log Cabins - Are supplied untreated and require a preservative and waterproofing treatment.

BUILDING A BASE

When thinking about where the building and base is going to be constructed:
Ensure that there will be access to all sides for maintenance work and annual treatment.

Ensure the base is level and is built on firm ground, to prevent distortion. Refer to diagrams for the base dimensions, The base should be slightly smaller than the external measurement of the building, i.e. The cladding should overlap the base, creating a run off for water. It is also recommended that the floor be at least 25mm above the surrounding ground level to avoid flooding.

TYPES OF BASE

- Concrete 75mm laid on top of 75mm hard-core.
- Slabs laid on 50mm of sharp sand.

Whilst all products manufactured are made to the highest standards of Safety and in the case of childrens products independently tested to EN71 level, we cannot accept responsibility for your safety whilst erecting or using this product.

Refer to the instructions pages for your specific product code



x2

All building's should be erected by two adults



Winter = High Moisture = Expansion
Summer = Low Moisture = Contraction



2mm Drill bit

For ease of assembly, you **MUST** pilot drill all screw holes and ensure all screw heads are countersunk.



CAUTION
Every effort has been made during the manufacturing process to eliminate the prospect of splinters on rough surfaces of the timber. You are strongly advised to wear gloves when working with or handling rough sawn timber.



For ease of assembly, you will need a tape measure to check dimensions of components.

Screws & Nails



Measure overall length

Bolts

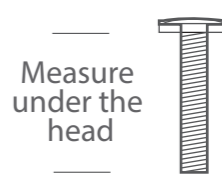

Measure under the head

To identify the fixings required for each step use a measuring tape.

****Protim Aquatan T5 (621)****

Your building has been dip treated with **Aquatan**.

Aquatan is a water-based concentrate which is diluted with water, the building as been treated by the correct application of Aquatan solution and then allowed to dry.

Aquatan is a decorative finish to colour the wood, which is applied industrially to timber fence panels and garden buildings.

Aquatan undiluted contains: boric acid, sodium hydroxide 32% solution, aqueous mixture of sodium dioctyl sulphosuccinat and alcohols: 2, 4, 6-trichlorophenol.



REGISTER FOR YOUR
ANTI-ROT
GUARANTEE TODAY

PLEASE SCAN HERE:



For assistance please contact customer care on: 01636 821215

Mercia Garden Products Limited,
Sutton On Trent,
Newark,
Nottinghamshire,
NG23 6QN



www.mercia garden products.co.uk

03DTSHHP1206HGD4MW-V1 & 03DTMBHP1206RFP

Please retain product label and instructions for future reference

Overall Dimensions:
 Width = 3690mm
 Depth = 1868mm
 Height = 2584mm

Base Dimensions:
 Width = 1753mm
 Depth = 3576mm

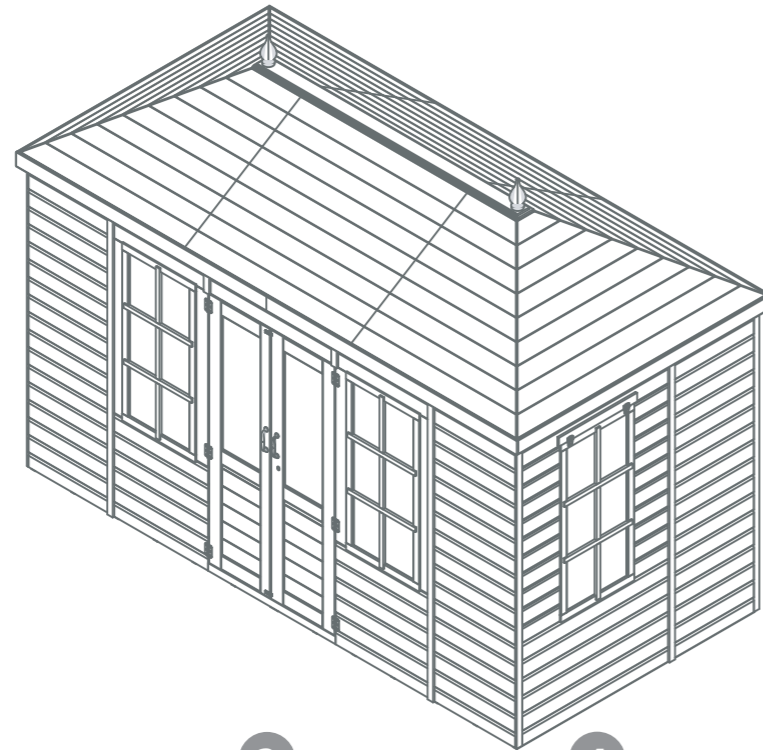









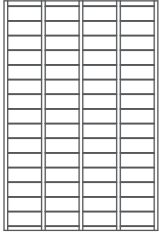
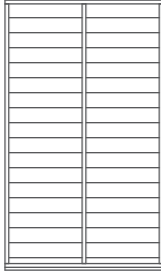
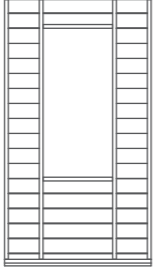
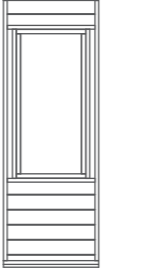

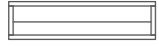
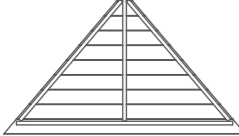
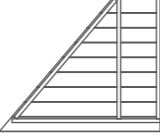
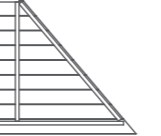
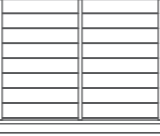
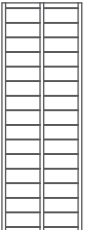
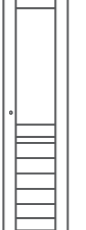
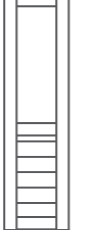



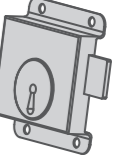

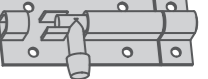

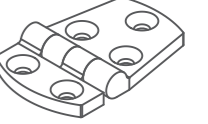









Before assembly
 please make sure you have a
 suitable base ready to erect your
 building



MADE IN GREAT BRITAIN

Building Content:

<p>1</p>  <p>Floor Panel AI-R11MBF1175X1753-V1 QTY 2</p>	<p>2</p>  <p>Back Panel AI-S11SHPP1180X2016 QTY 2</p>	<p>3</p>  <p>Side Window Panel AI-03S11SH15FWC1094X2016 QTY 2</p>	<p>4</p>  <p>Front Window Panel AI-03S11SH15FWC710X2016-V1 QTY 2</p>	<p>5</p>  <p>Plain Panel AI-S11SHPP613X2016-V1 QTY 6</p>
<p>6</p>  <p>Upper Door Panel AI-S11SHPPBF940X242-V1 QTY 1</p>	<p>7</p>  <p>6Ft Roof AI-S11MBDANGR1830X1028-V1 QTY 2</p>	<p>8</p>  <p>Right Roof 8Ft AI-S11MBANGRR1213X1028-V1 QTY 2</p>	<p>9</p>  <p>Left Roof 8Ft AI-S11MBANGRL1213X1028-V1 QTY 2</p>	<p>10</p>  <p>Centre Roof AI-S11MBSHPR1226X1028-V1 QTY 2</p>
<p>11</p>  <p>Small Floor AI-R11MBF613X1753-V1 QTY 2</p>	<p>12</p>  <p>Master Door AI-STDHGMD475X1715-V1 QTY 1</p>	<p>13</p>  <p>Secondary Door AI-STDHGPD475X1715-V1 QTY 1</p>		

<p>14</p>  <p>Roof Bearer A - 44x58x2211mm QTY 1 F4458-G-2251mm (2x32° CUTS)</p>	<p>29</p>  <p>Press Lock QTY 1 PI-07-0162</p>
<p>15</p>  <p>Roof Bearer B - 44x58x528mm QTY 5 F4458-G-568mm (2x32° CUTS)</p>	<p>30</p>  <p>Tower Bolt QTY 2 PI-07-0114</p>
<p>16</p>  <p>Roof Bearer Block - 44x58x84mm QTY 5 F4458-84mm</p>	<p>31</p>  <p>Unequal Hinge QTY 4 PI-07-0184</p>
<p>17</p>  <p>Window Cross - 16x27x1094mm QTY 4 WC1627-1094mm</p>	<p>32</p>  <p>Casement Stay QTY 2 PI-07-0007</p>
<p>18</p>  <p>Window Cross - 16x27x500mm QTY 8 WC1627-500mm</p>	<p>33</p>  <p>Finial QTY 2 PI-04-0023</p>
<p>19</p>  <p>Fascia - 12x95x1870mm QTY 4 SR1295-1870mm</p>	<p>34</p>  <p>Felt</p>
<p>20</p>  <p>Fascia - 12x95x1920mm QTY 3 SR1295-1920mm</p>	<p>35</p>  <p>Window QTY 2 AI-FW540X1132-V1</p>
<p>21</p>  <p>Door Stop Frame - 28x28x940mm QTY 1 FS2828-940mm</p>	<p>36</p>  <p>Butt Hinge QTY 6 PI-07-0066</p>
<p>22</p>  <p>Eaves Frame - 28x28x1805mm QTY 6 FS2828-1805mm</p>	<p>37</p>  <p>Turn Button QTY 2 PI-07-0034</p>
<p>23</p>  <p>Window Strip - 12x56x576mm QTY 2 S1256-576mm</p>	<p>38</p>  <p>Door Handle QTY 2 PI-07-0081</p>
<p>24</p>  <p>Door Strip - 12x49x940mm QTY 1 S1249-940mm</p>	
<p>25</p>  <p>Flat Roof Strip - 12x120x1950mm QTY 1 MB12-1950mm</p>	
<p>26</p>  <p>Cover Trim - 12x40x1970mm QTY 12 S1240-1970mm</p>	
<p>27</p>  <p>Door Frame Strip - 12x40x1740mm QTY 2 S1240-1740mm</p>	
<p>28</p>  <p>Door Frame Strip - 12x40x996mm QTY 1 S1240-996mm</p>	

Nail Bag

There may be extra screws present in the nail bag



Pre Assembly

Remove the transportation blocks from the bottom and top of each panel before beginning assembly.

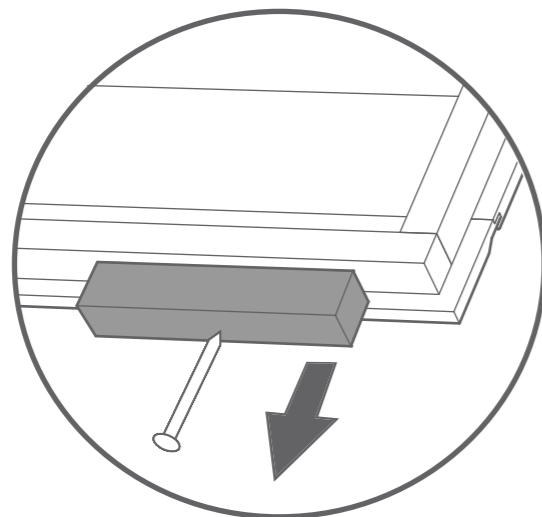

Step 1

**Parts needed - No. 21 QTY 1
No. 24 QTY 1**

Secure the Door Strip (**No. 24**) with the edges being flush to the Door Stop Frame (**No. 21**) using 5x30mm screws.

5 x 30mm Screws

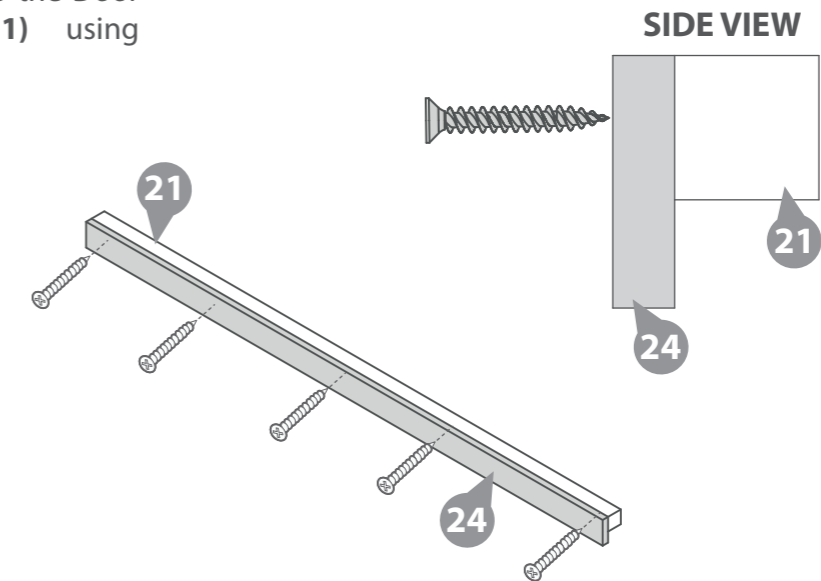

Step 2

**Parts needed - No. 4 QTY 2
No. 6 QTY 1
No. 21 QTY 1
No. 24 QTY 1**

Lay all of the required parts on to a flat level surface and fix the Upper Door Panel (**No. 6**) in the centre of the two Front Window Panels (**No. 4**) with 3x50mm screws per side. The Upper Door Panel should be flush with the top of the left and right Panels.

Fix the (already assembled in the Step 1.) Door Strip (**No. 24**) and the Door Stop Frame (**No. 21**) to the bottom of the Front Window Panels (**No. 4**) with 2x50mm screws per side. The Door Stop Frame should be flush with the bottom framing of the Front Window Panels (**No. 4**).

10 x 50mm Screws

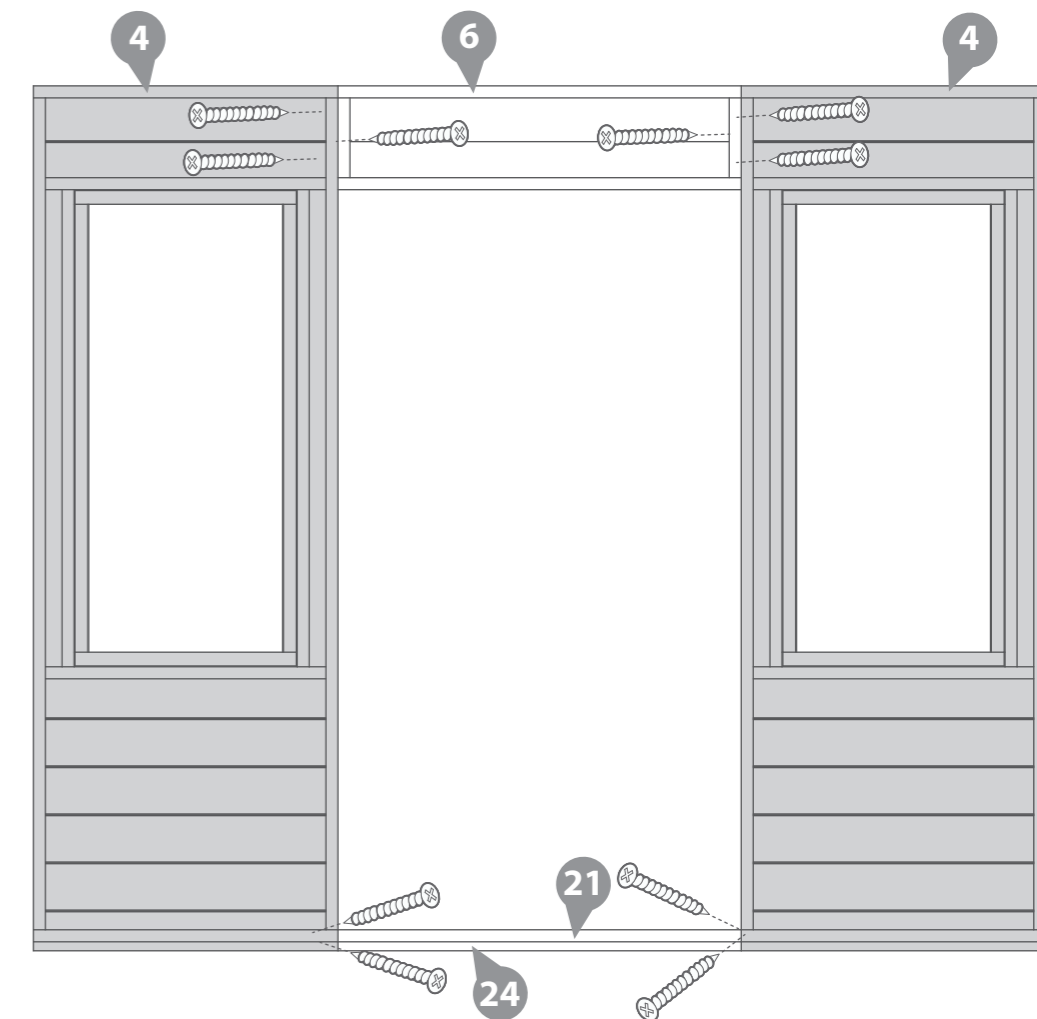

Step 3

Parts needed - No. 4 QTY 2
No. 12 QTY 1
No. 13 QTY 1
No. 36 QTY 6

Fix the Secondary Door (**No. 13**) to the Front Window Panel (**No. 4**).

Secure the Butt Hinges (**No. 36**) to the Front Window Panel (**No. 4**) with 3x30mm screws per hinge.

Then fix the Butt Hinges (**No. 36**) to the door with 3x25mm screws per hinge.

Repeat the process for the Master Door (**No. 12**).

18 x 25mm Screws
18 x 30mm Screws

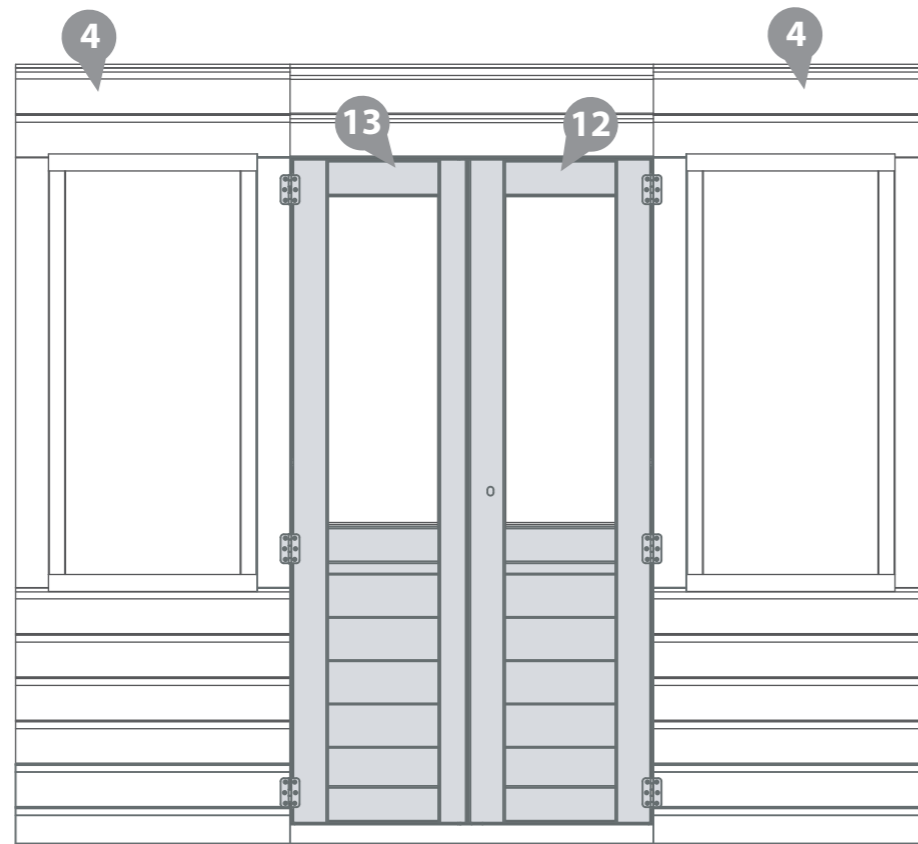

Step 4

Parts needed - No. 1 QTY 2

Secure the floors (**No. 1**) together using 8x50mm screws through the floor bearers in an alternating pattern.

8x50mm Screws

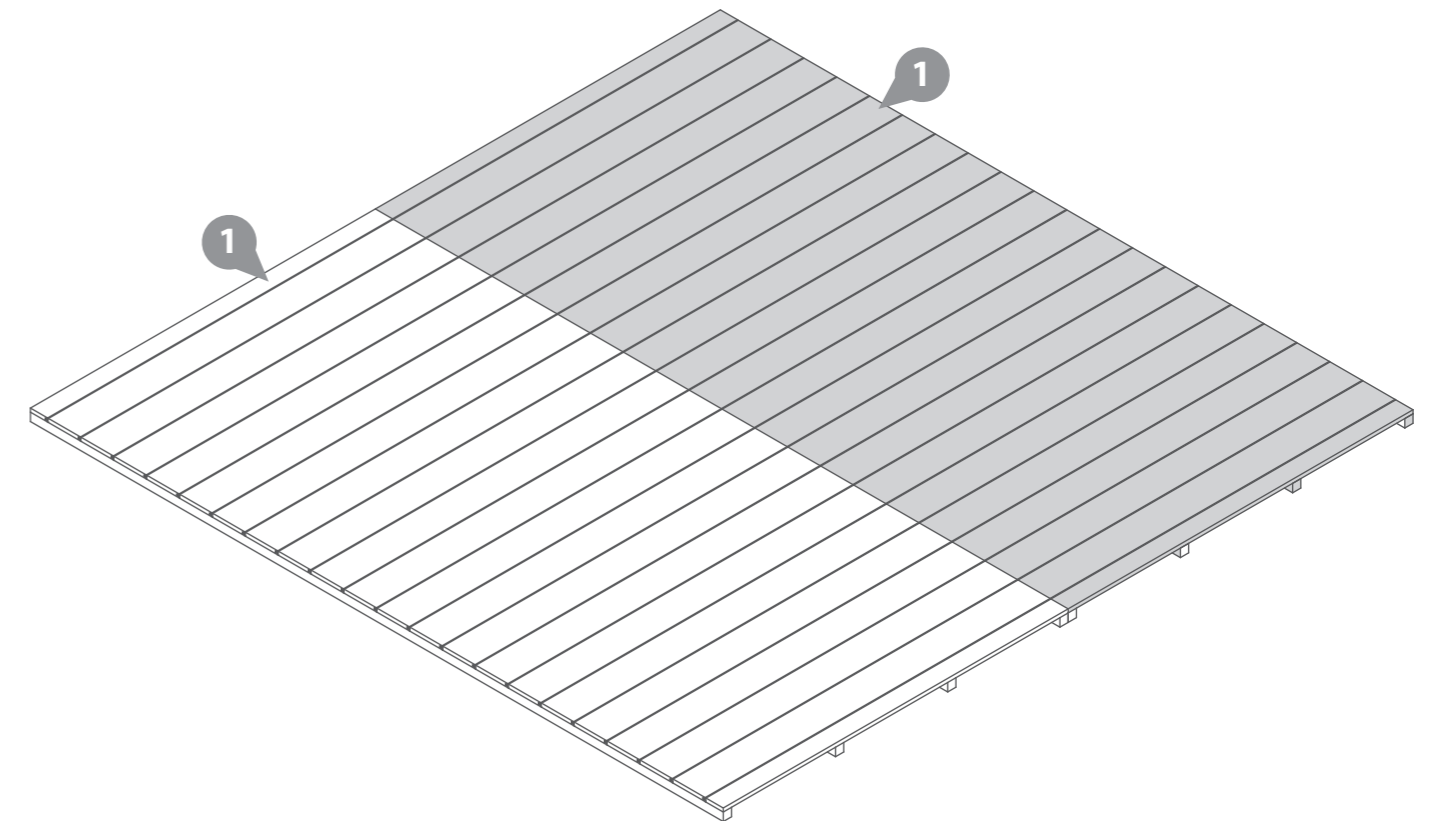
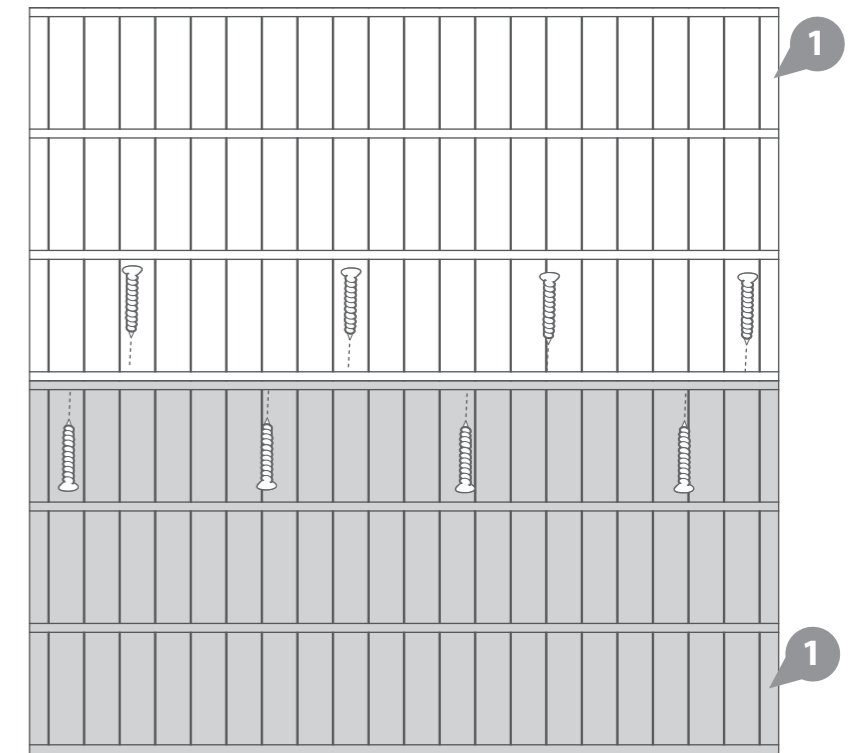

secondary Door

Master Door

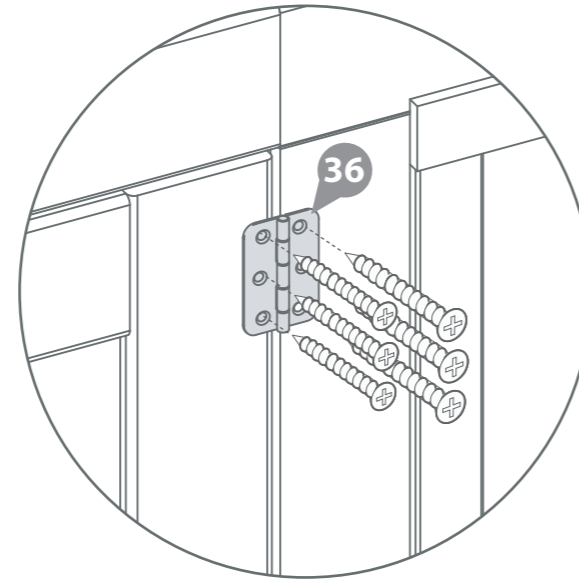
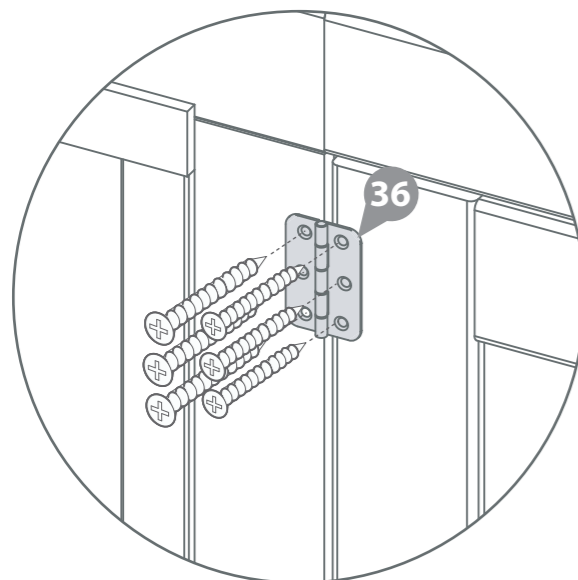

Step 5

Parts needed - No. 11 QTY 2

Secure the Small Floor Panels (No. 11) to the floors assembled in the previous step using 8x50mm screws through the floor bearers in an alternating pattern.

Once fixed together turn the floor back the right way up.

Place the assembled floor panels (No. 1 & 11) onto a firm and level base. Ensure the base has suitable drainage, free from areas where standing water can collect.

16x50mm Screws

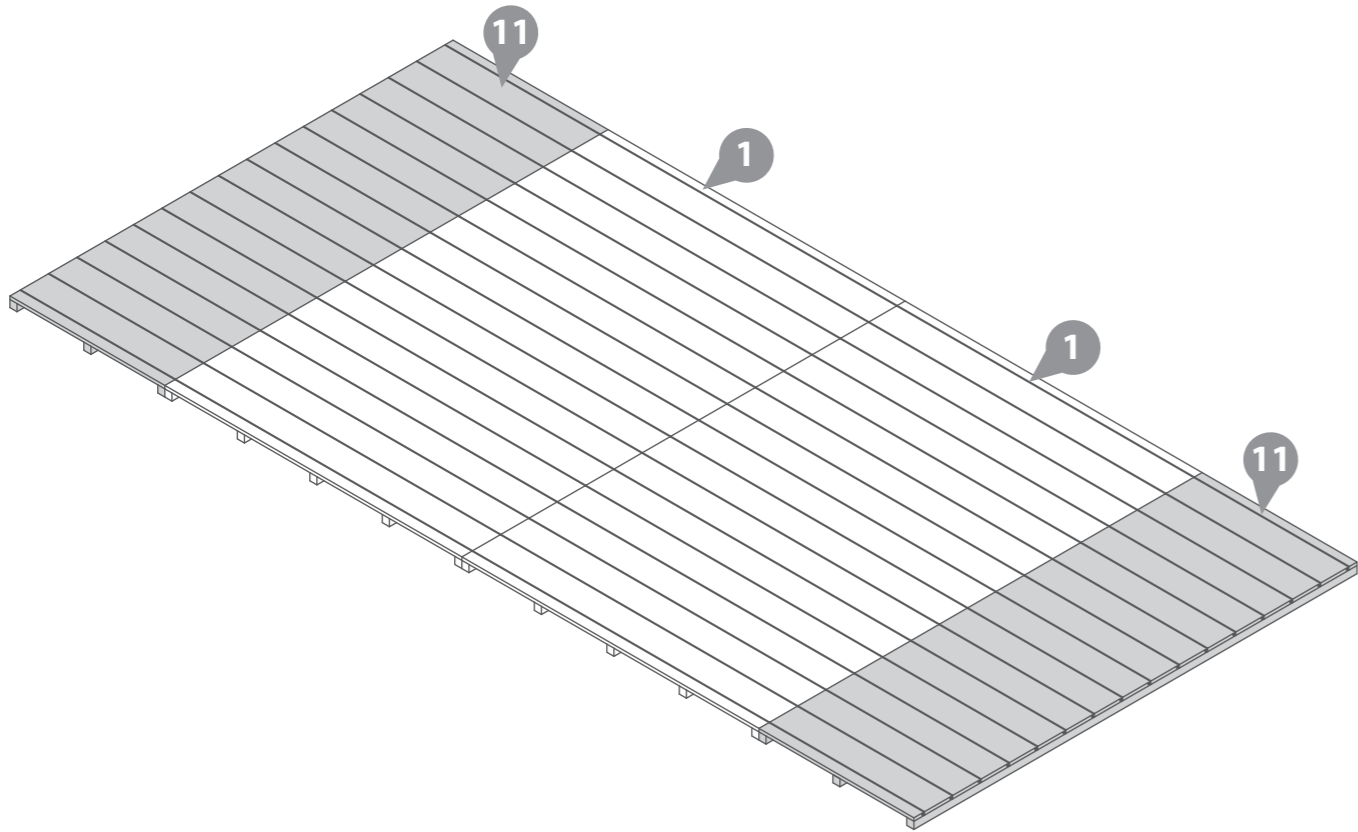
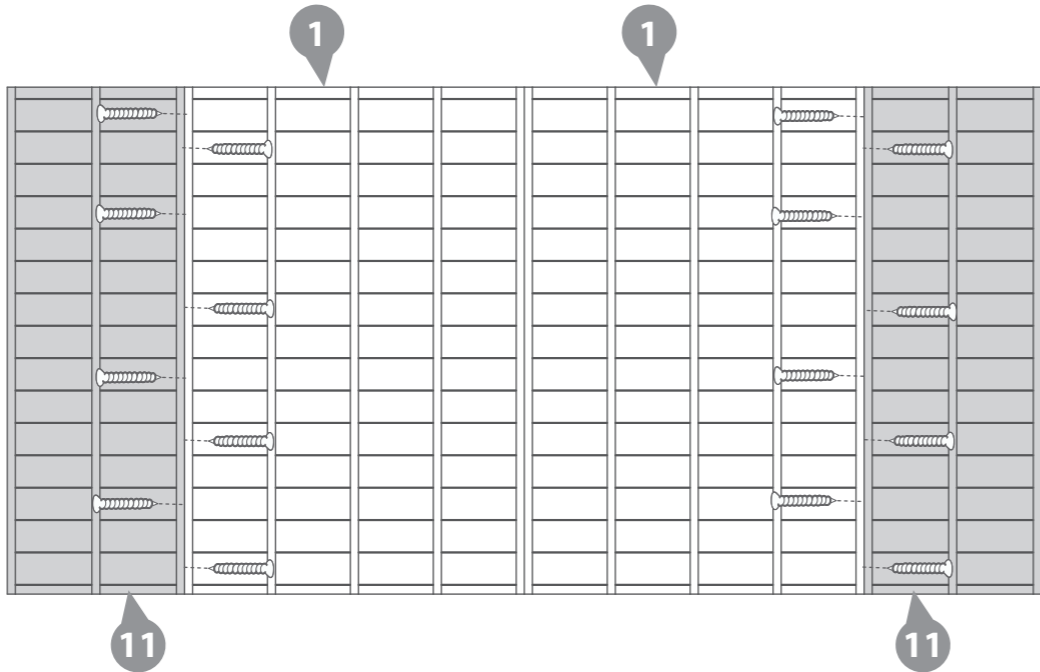

Step 6

**Parts needed - No. 3 QTY 2
No. 5 QTY 2**

Fix the Side Window Panel (No. 3) and the Plain Panel (No. 5) together by screwing through the framing using 5x50mm screws.

Ensure to stagger screws to avoid colliding.

Repeat this with the second Side Window Panel and the Plain Panel but the opposite way round, as shown in the diagram.

10x50mm Screws



****Please note that when you fix the Plain Panel (No. 5) to the second Side Window Panel (No. 3), this is to be fitted to the opposite side.**

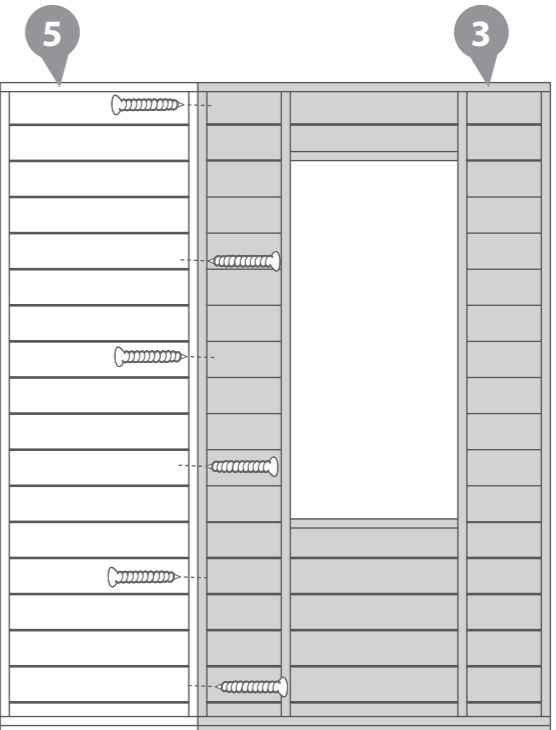
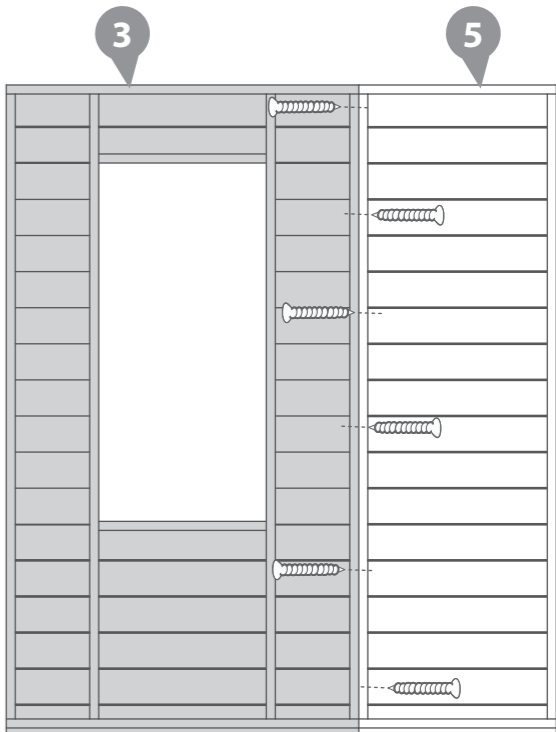

Step 7

**Parts needed - No. 2 QTY 2
No. 5 QTY 2**

Fix the Back Panel (**No. 2**) and the Plain Panel (**No. 5**) together by screwing through the framing using 5x50mm screws.

Ensure to stagger screws to avoid colliding.

Repeat this with the second Back Panel and the Small Side Panel but the opposite way round, as shown in the diagram.

10x50mm Screws

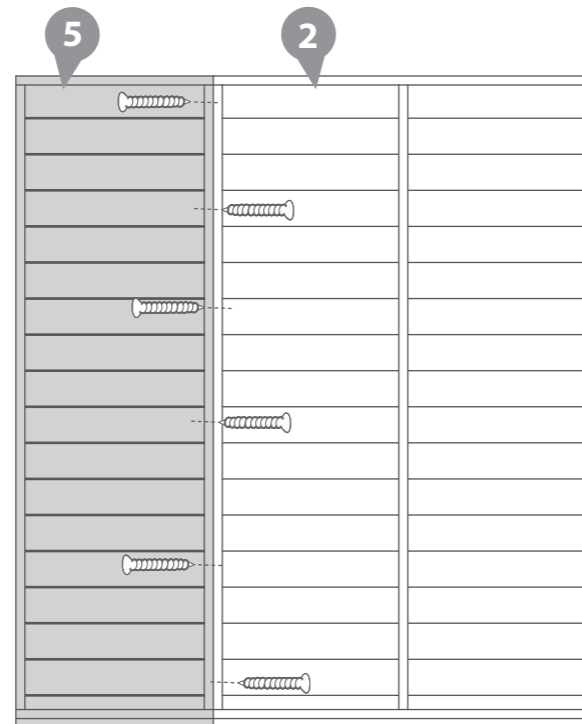

****Please note that when you fix the Plain Panel (No. 5) to the second Back Panel (No. 2), this is to be fitted to the opposite side.**

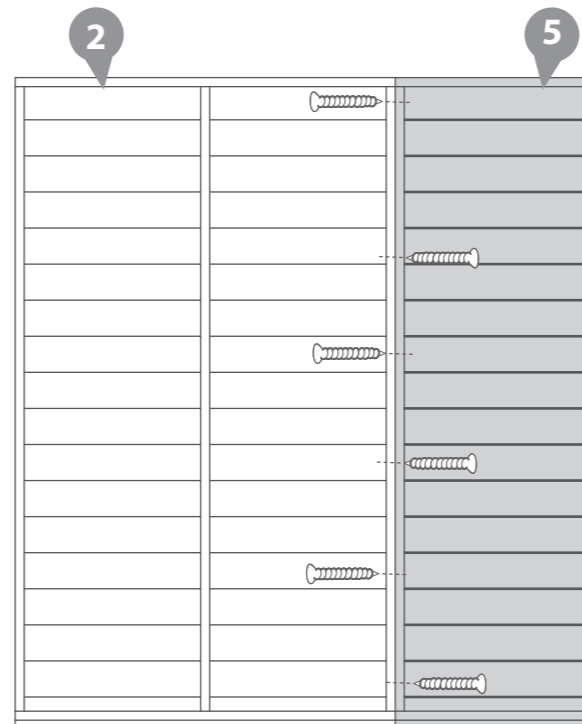

Step 8

**Parts needed - No. 2 QTY 1
No. 3 QTY 1
No. 5 QTY 2**

Place the two Plain Panels (**No. 5**) that were assembled with the Side Window Panel (**No. 3**) and the Back Panel (**No. 2**) in the previous steps into position and fix together with 3x50mm screws.

****Do not secure to the Floor until the Roof is fixed in position**

3x50mm Screws

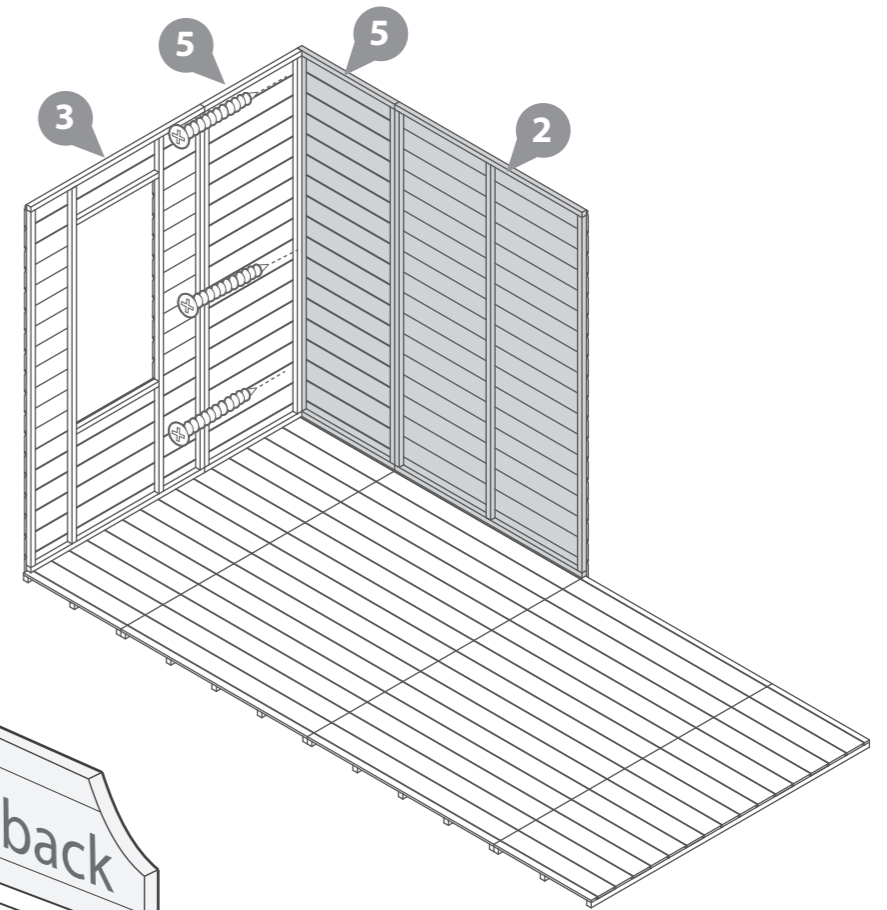
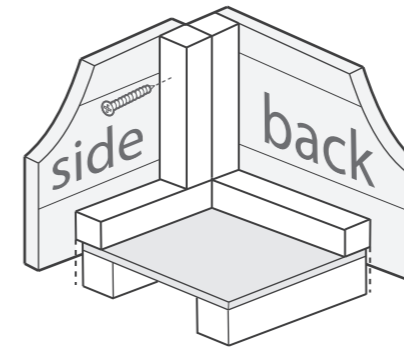

Step 9

**Parts needed - No. 2 QTY 1
No. 5 QTY 1**

Place the second Back Panel (**No. 2**) and Plain Panel (**No. 5**) (that were assembled in Step 7.) in position and fix with 6x50mm screws.

****Ensure to stagger screws to avoid colliding.**

****Do not secure to the Floor until the Roof is fixed in position**

6x50mm Screws

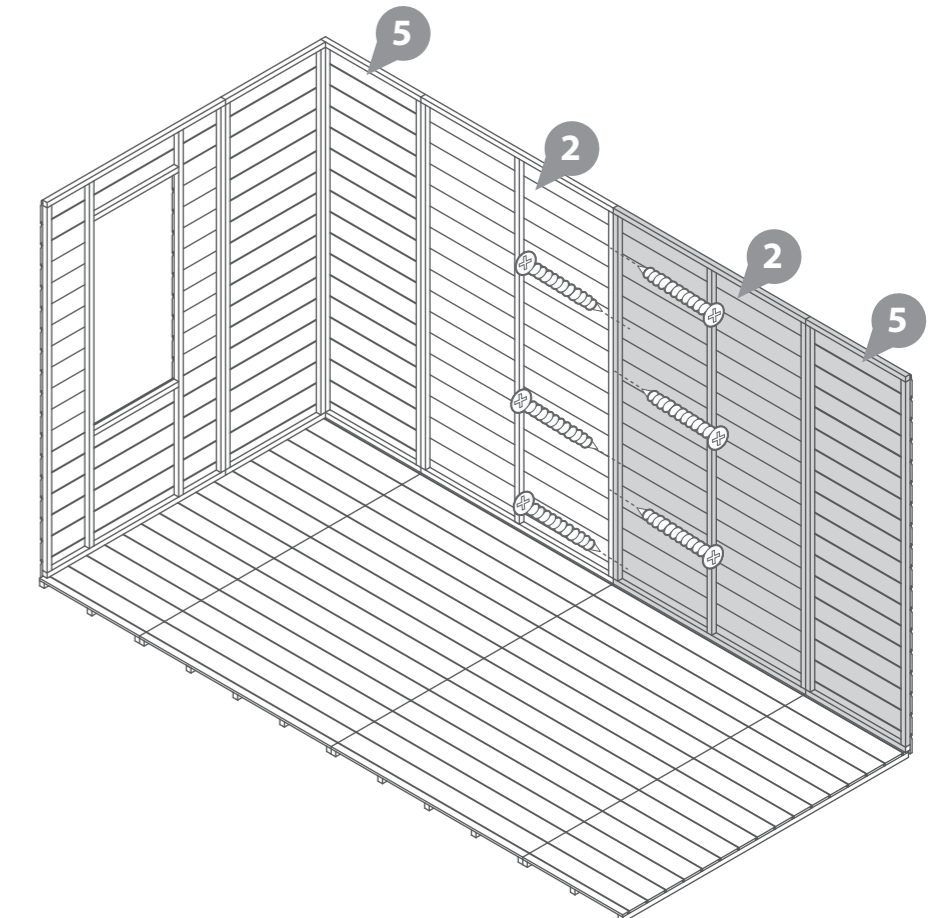

Step 10

**Parts needed - No. 3 QTY 1
No. 5 QTY 1**

Place the Plain Panel (No. 5) that is already assembled with the Side Window Panel (No. 3) in position in a previous step and fix together with the Plain Panel (No. 5) using 3x50mm screws.

****Do not secure to the Floor until the Roof is fixed in position.**

3x50mm Screws

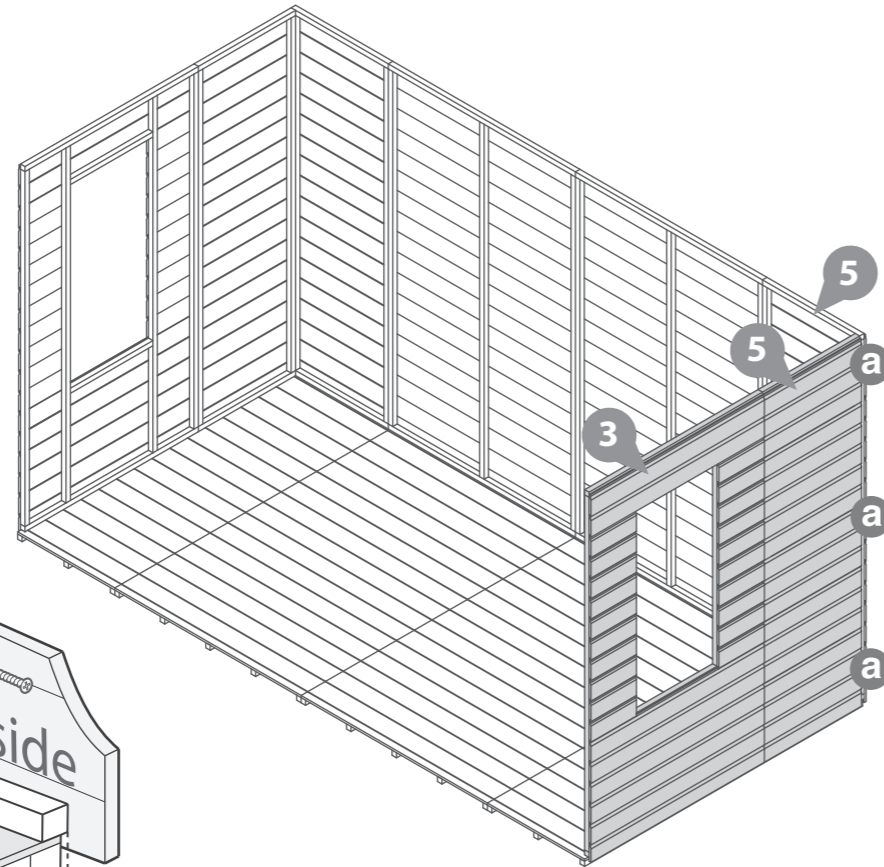
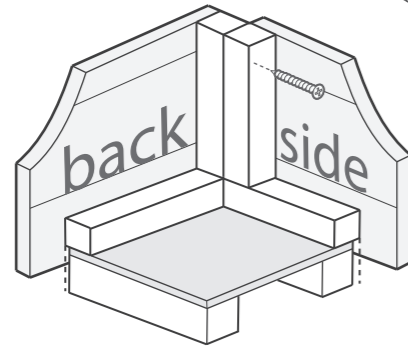

Step 11

Parts needed - No. 5 QTY 2

Place the two Plain Panel (No. 5) into position and fix to the Side Window Panels (No. 3) with 3x50mm screws per side.

****Do not secure to the Floor until the Roof is fixed in position**

6x50mm Screws

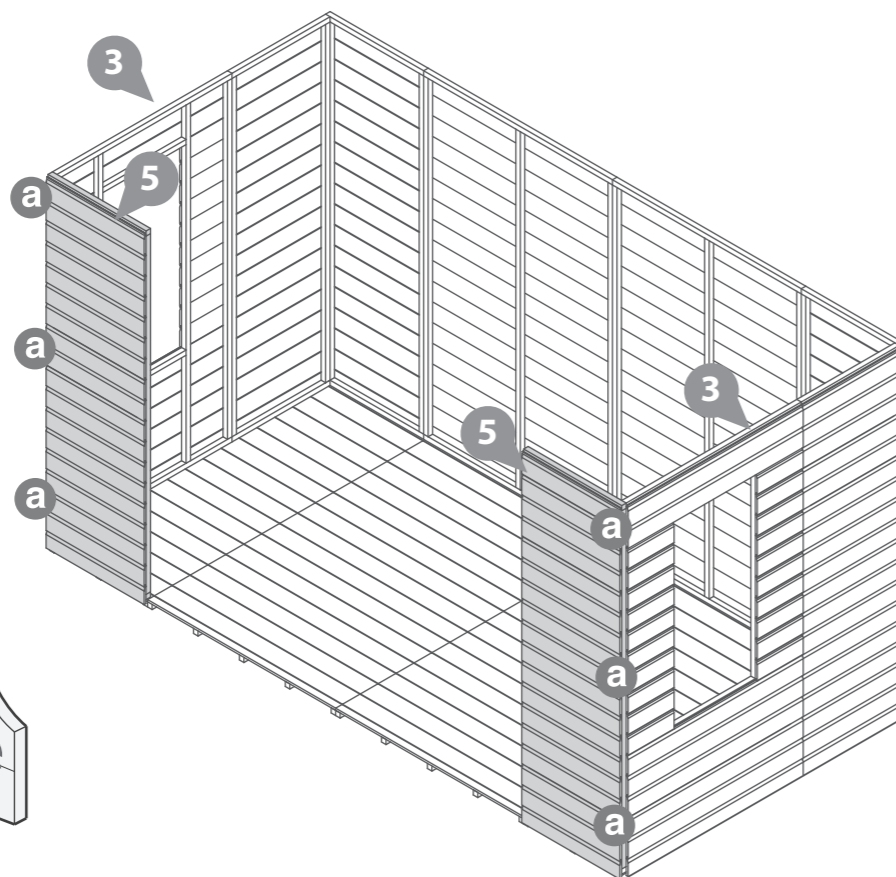
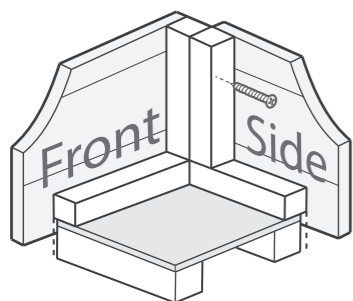

Step 12

Parts needed - No. 4 QTY 2

Place the already assembled Door Panel (No. 4, 6, 12, 13, 22 & 25) into position and fix together with the two front plain panels (No. 5) 3x50mm screws per side.

If the door panel has not been assembled yet, please refer to Step 1, 2 & 3.

****Do not secure to the Floor until the Roof is fixed in position.**

16x50mm Screws

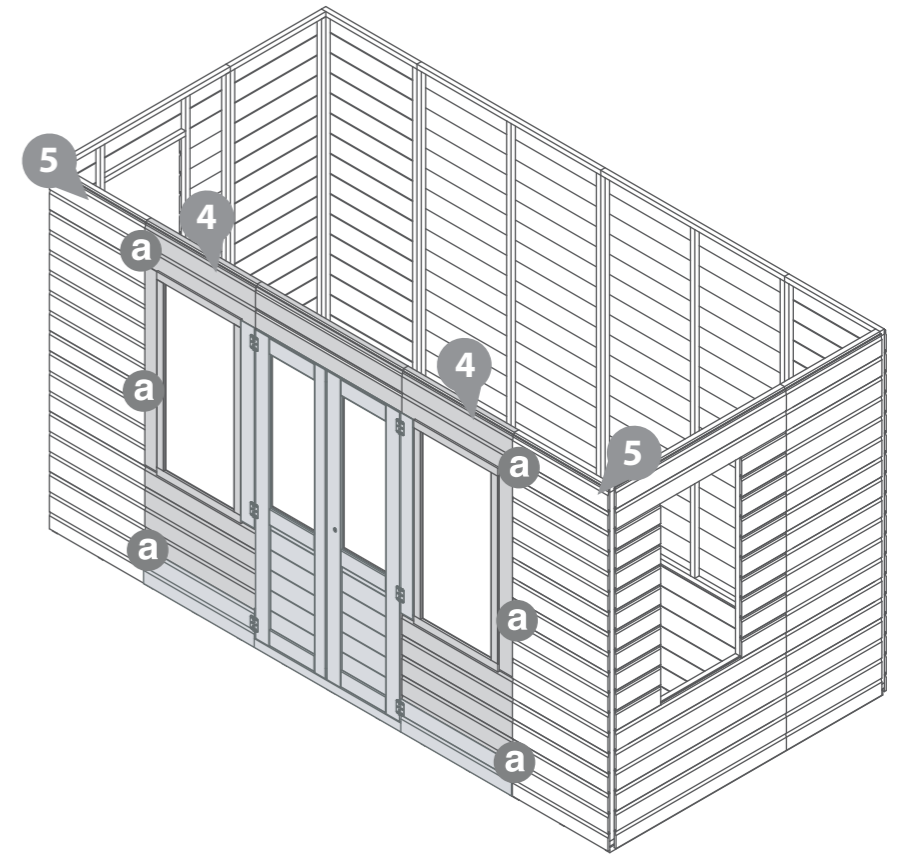

Step 13

**Parts needed - No. 8 QTY 2
No. 9 QTY 2
No. 10 QTY 2**

Fix the Left and Right Roof Panels (No. 8 & 9) to either side of the Centre Roof (No. 10) Panel by screwing through the framing using 8x50mm screws per assembly.

repeat this action for the other roof side.

****Ensure to stagger screws to avoid colliding.**

16x50mm Screws

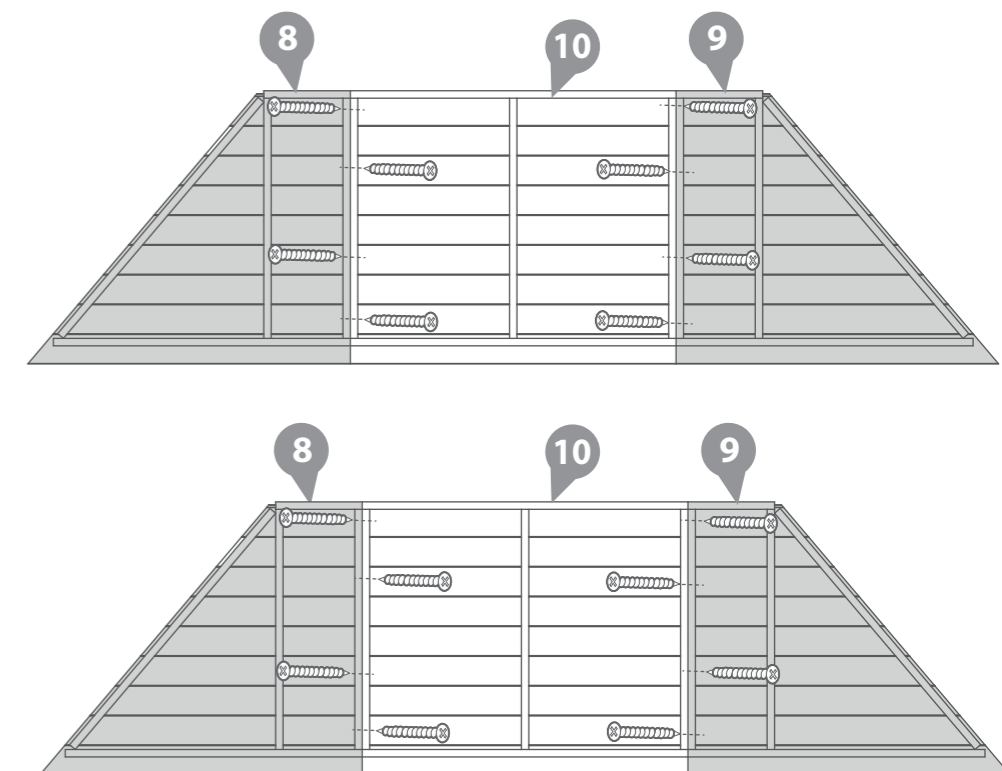

Step 14
Parts needed - No. 7 QTY 2
No. 8 QTY 2
No. 9 QTY 2
No. 10 QTY 2
No. 34 QTY 1

Roll out the Felt (No. 34) and use the Roof Panels (No. 7, 8, 9 & 10) as shown in the illustration so you can accurately cut the felt before fitting.

Leave a 100mm space between each panel and cut through the centre to create 50mm overhang for each strip. Make sure that there is a 50mm overhang under each panel

Measure and cut four strips of felt (No. 34) at 1600x200mm.

Measure and cut one full width strip of felt (No. 34) at 2600mm long.

Once all the pieces of felt have been cut keep these to one side whilst you construct the roof.

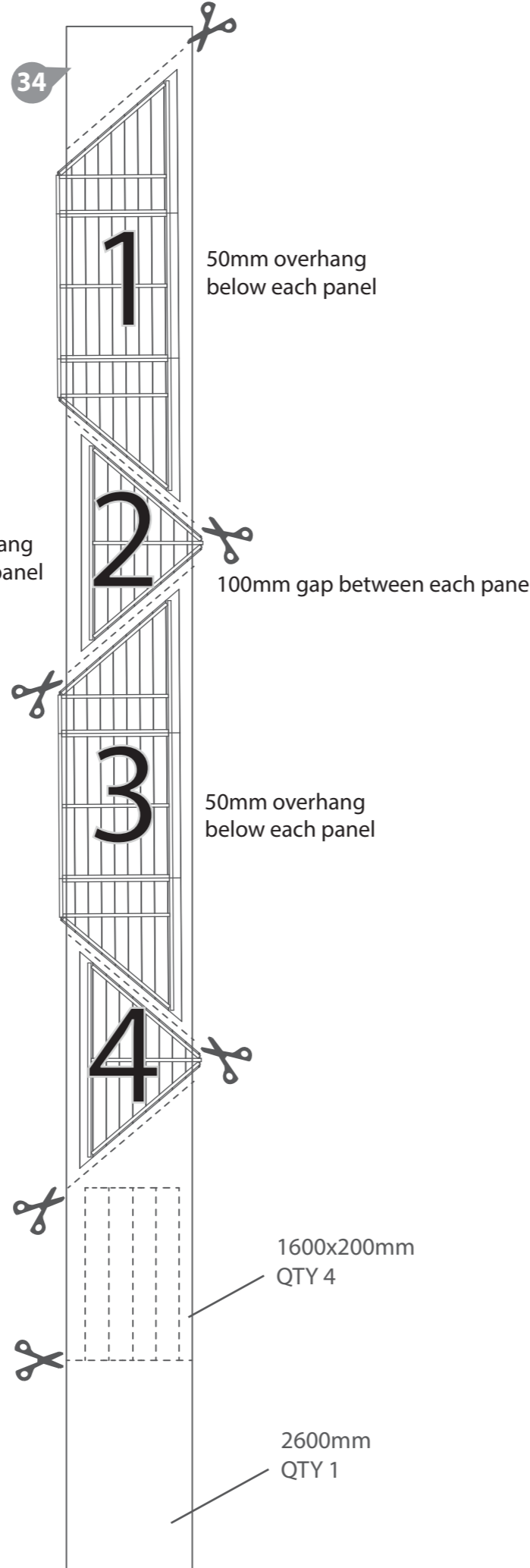
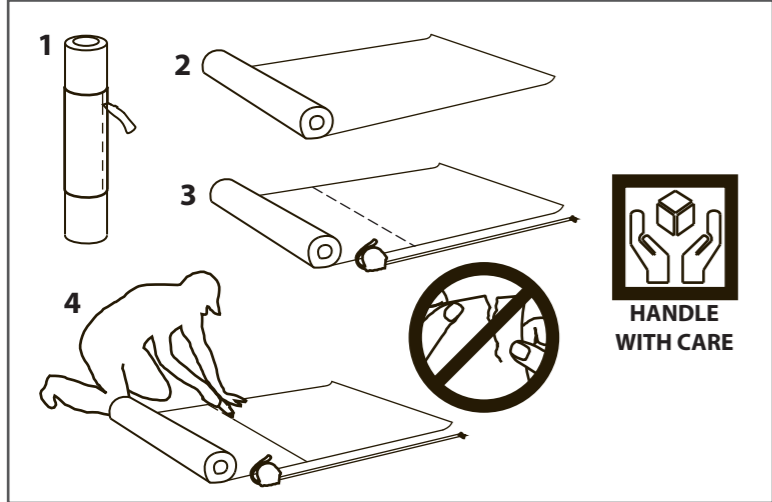

Step 15
Parts needed - No. 14 QTY 1
No. 15 QTY 5

Pre drill holes in the underside of Roof Bearer A (No. 14) and all 5 of the Roof Bearer B (No. 15) parts with an offset position of 40 mm from each of the pointed ends in the centre of the bearers. These holes are going to later receive 60mm screws.

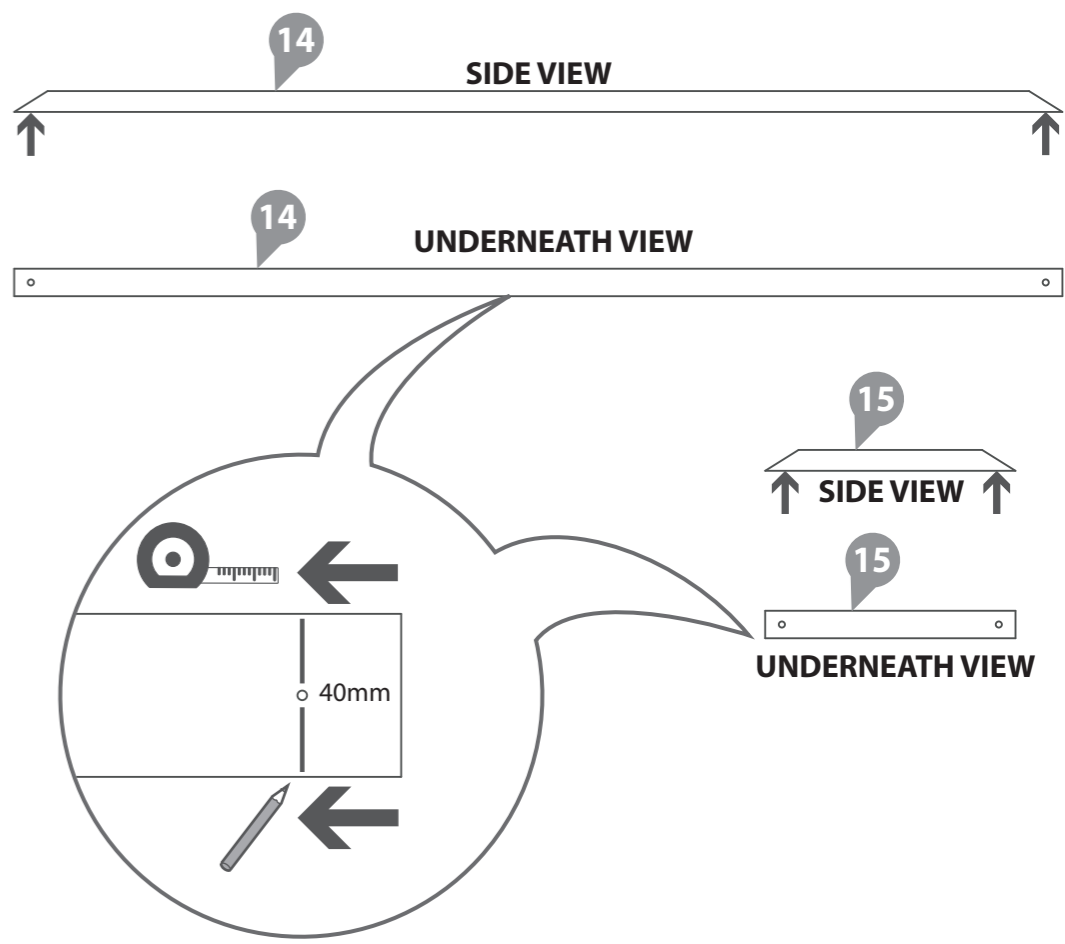

Step 16
Parts needed - No. 7 QTY 2

Place both 6ft Roof Panels (No. 7) on the floor and measure 195mm from the top of the Framing and mark the distance on the vertical framing with a line.

Repeat this step for both roof 6ft Roof Panels (No. 7).

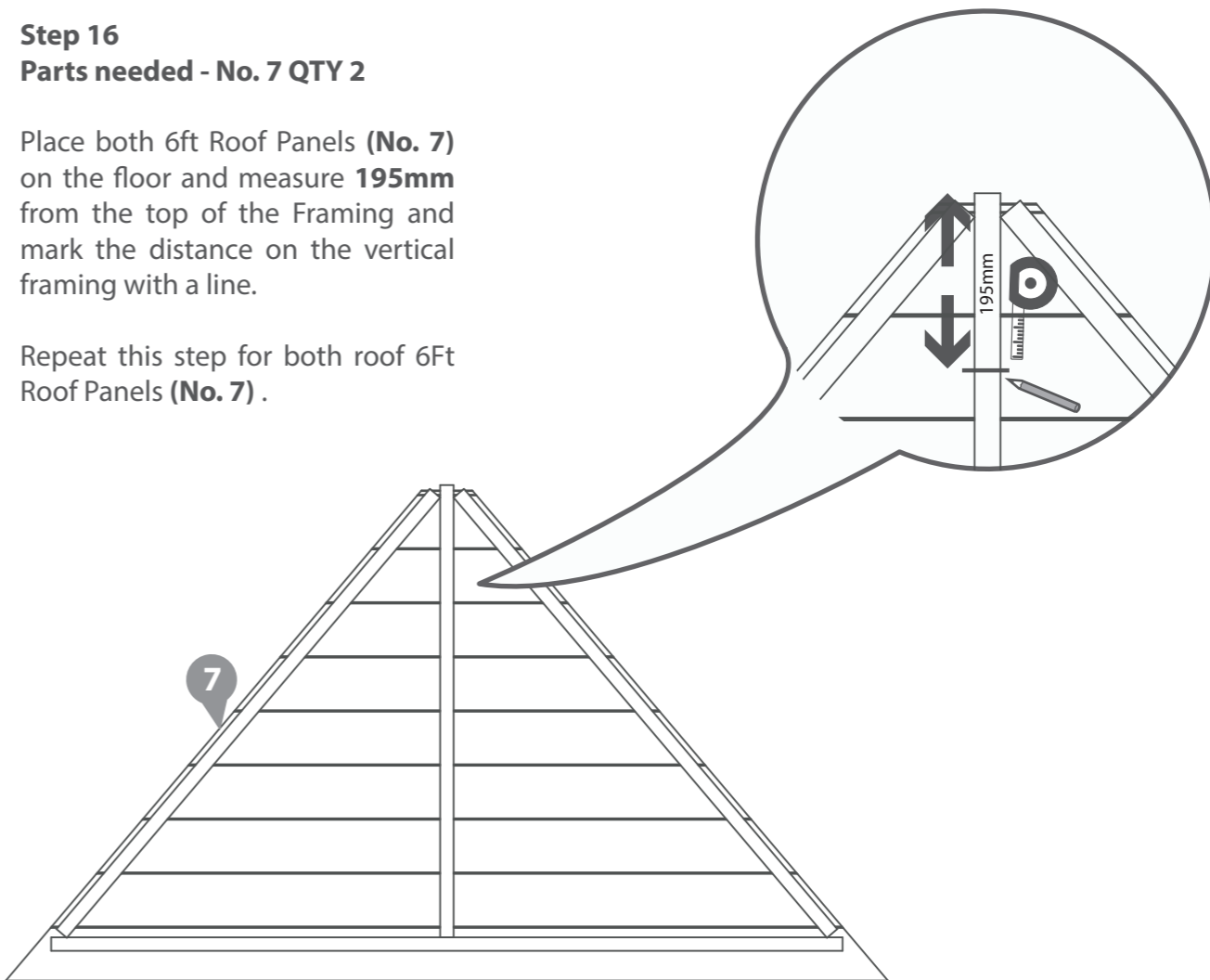

Step 17

Parts needed - No. 8 QTY 2
No. 9 QTY 2
No. 10 QTY 2

Place the recently assembled roof panels (**No. 8, 9 & 10**) on the floor and measure **280mm** from the top of the Framing and mark the distance on all of the vertical framings with a line.

If these panels have not been assembled yet, please refer to step 13.

Repeat this step for both sets of assembled roof panels (**No. 8, 9 & 10**).

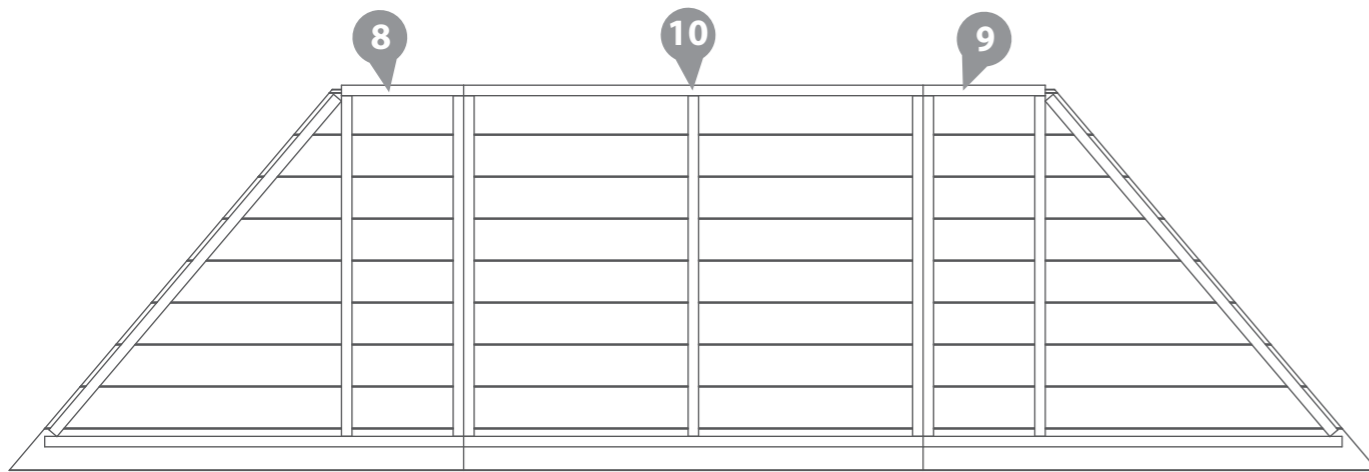
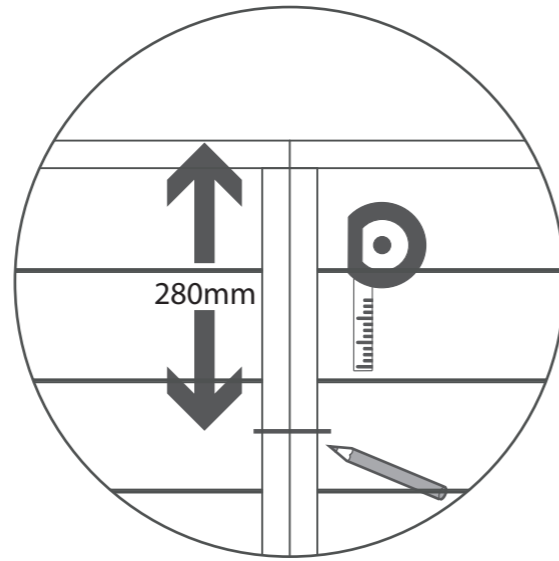

Step 18

Parts needed - No. 14 QTY 1
No. 16 QTY 5

Fix the Roof Blocks (**No. 16**) to Roof Bearer A (**No. 14**) using 2x70mm screws per roof block. Screw up through the bearer into the block using the dimensions shown.

****Place tape measure under the bottom pointed corner and measure and mark from this point.**

10x70mm Screws

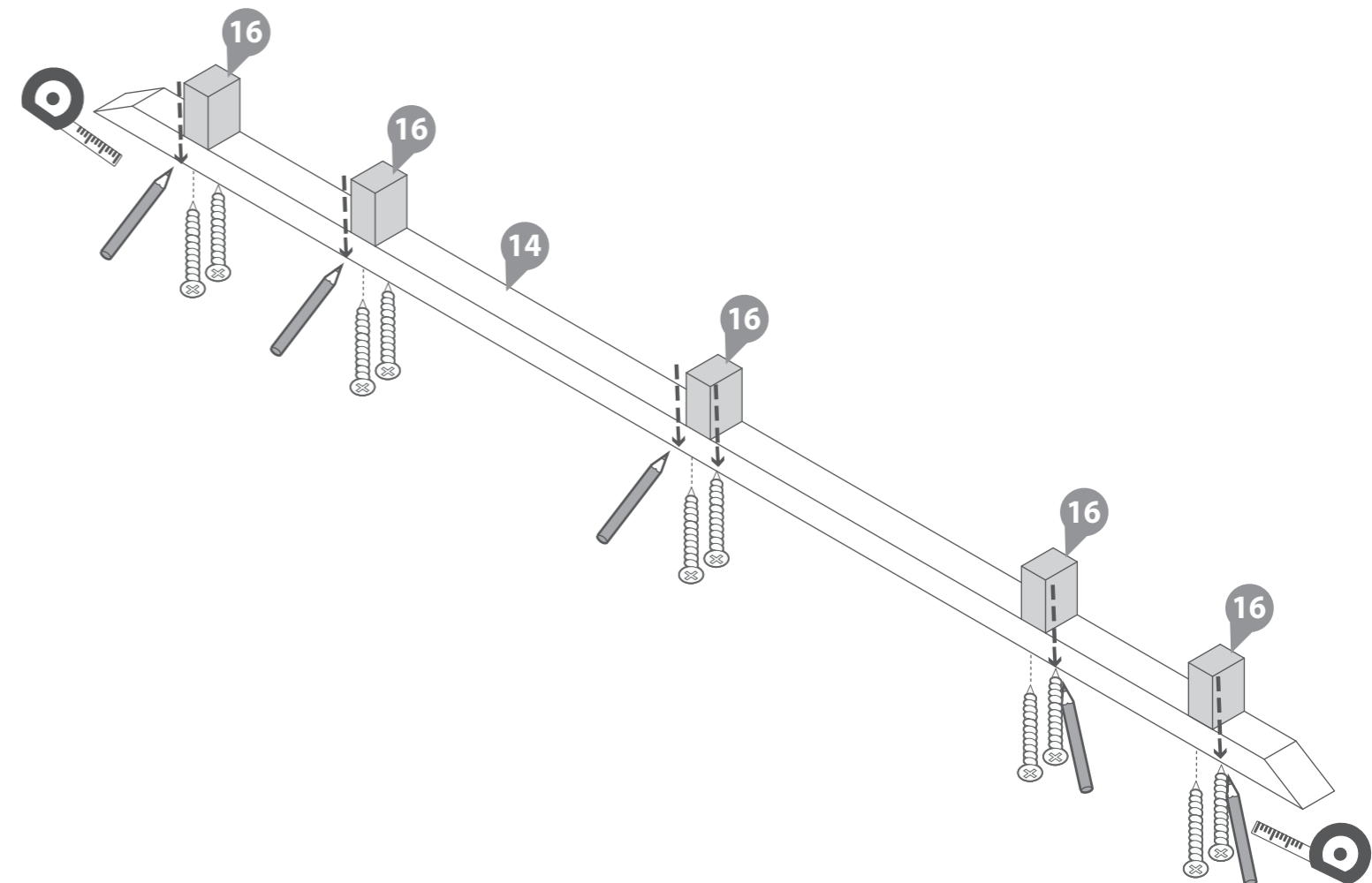
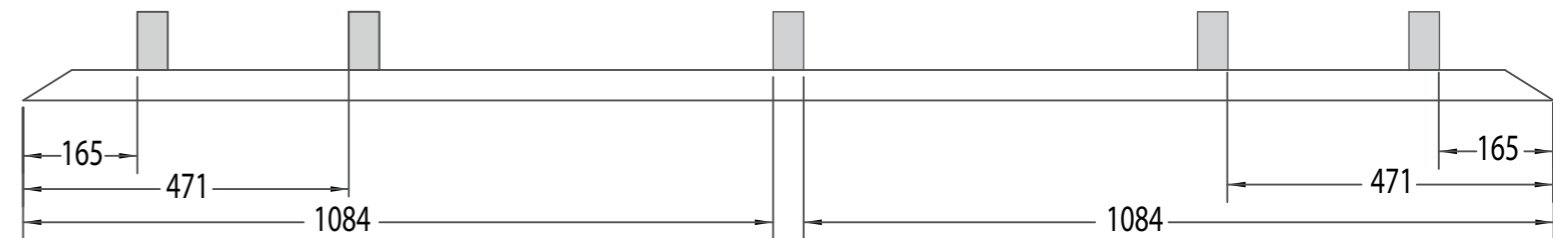
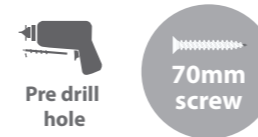

Step 19

**Parts needed - No. 7 QTY 1
No. 14 QTY 1**

Place one of the 6Ft Roof Panels (**No. 7**) on the floor. Place the main Roof Bearer A (**No. 14**) flat on the bevelled end with the pointed corner meeting the line drawn in Step 16.

Fix Roof Bearer A (**No. 14**) to the 6Ft Roof Panels (**No. 7**) by using a 60mm screw in the pre drilled hole that was made in Step 15.

1x60mm Screws

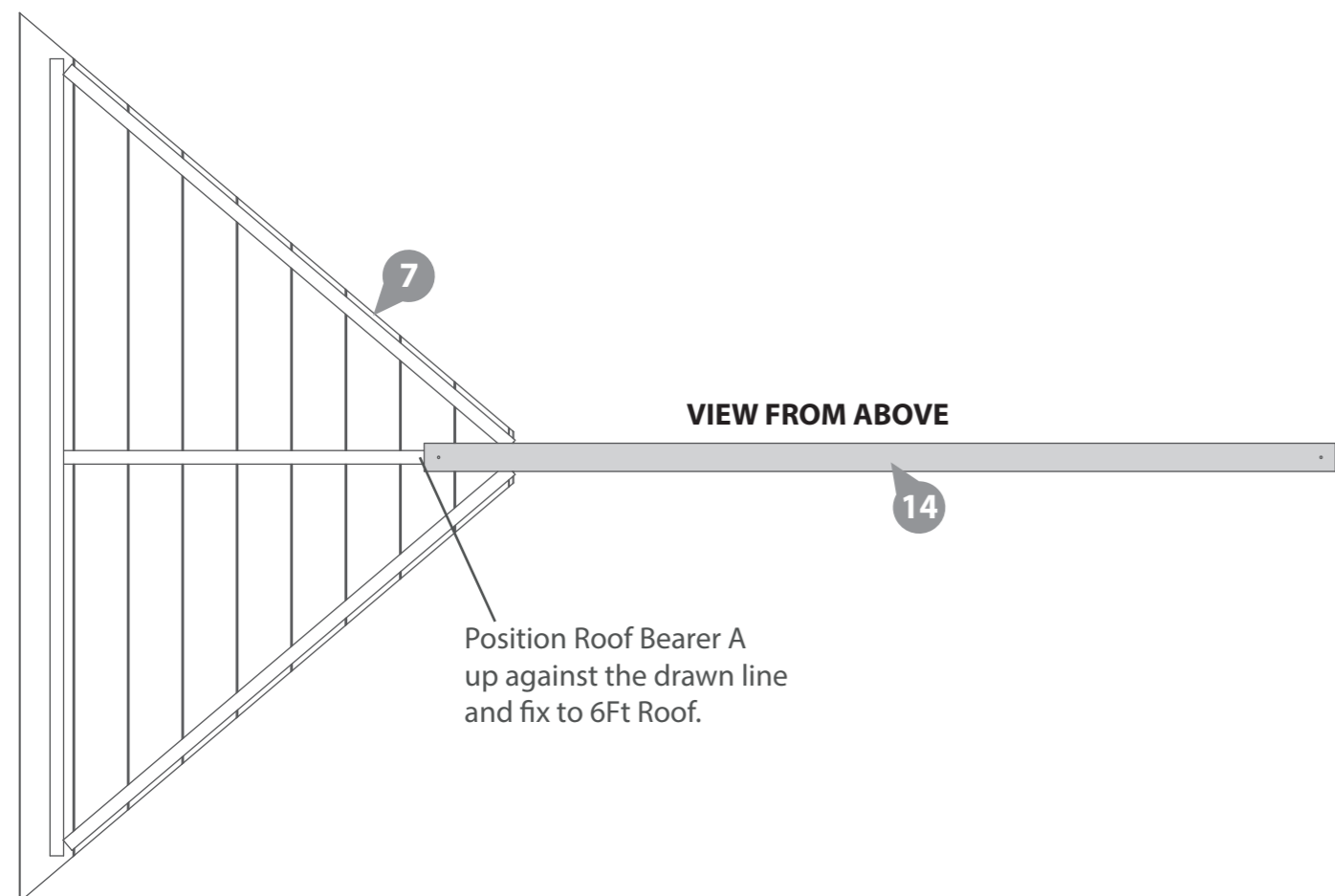
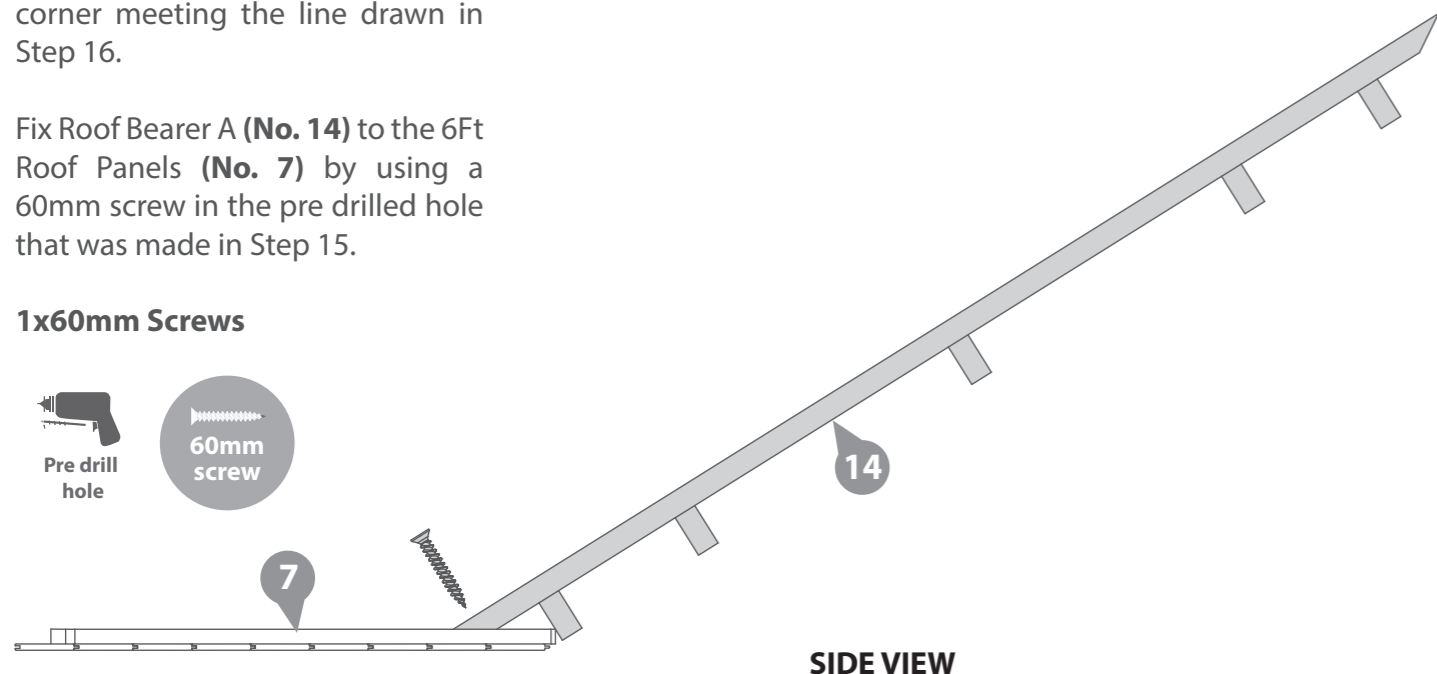
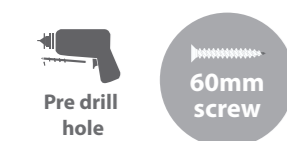

Step 20

**Parts needed - No. 7 QTY 2
No. 8 QTY 1
No. 9 QTY 1
No. 10 QTY 1
No. 14 QTY 2
No. 16 QTY 5**

The use of a step ladder is essential to construct the roof.

A To construct the Roof, place the previously assembled (in Step 19) 6ft Roof Panel (**No. 7**) and Roof Bearer A (**No. 14**) on top of the Summer House and let the pointed edge on the other end of the bearer meet the line drawn (in Step 16) on the second 6ft Roof Panel (**No. 7**).

B When in position, Use 1x60mm screw to fix up through the previous drilled hole (in Step 15) of the bearer into the roof frames. The bevelled end of the bearer must be flat against the roof.

C Once secure, place the third set of roof panels previously assembled (in Step 13) onto the building as shown.

You will secure it in the next couple of steps.

1x60mm Screws

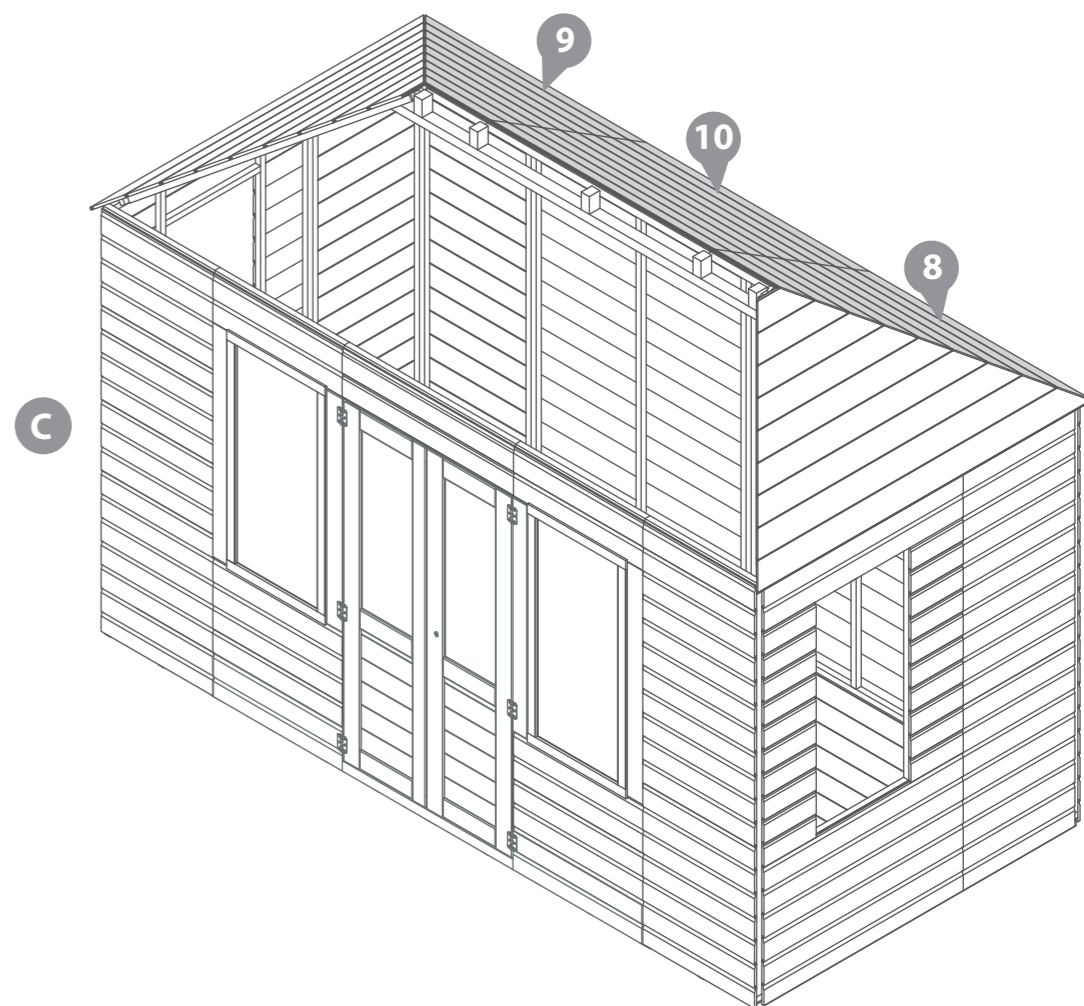
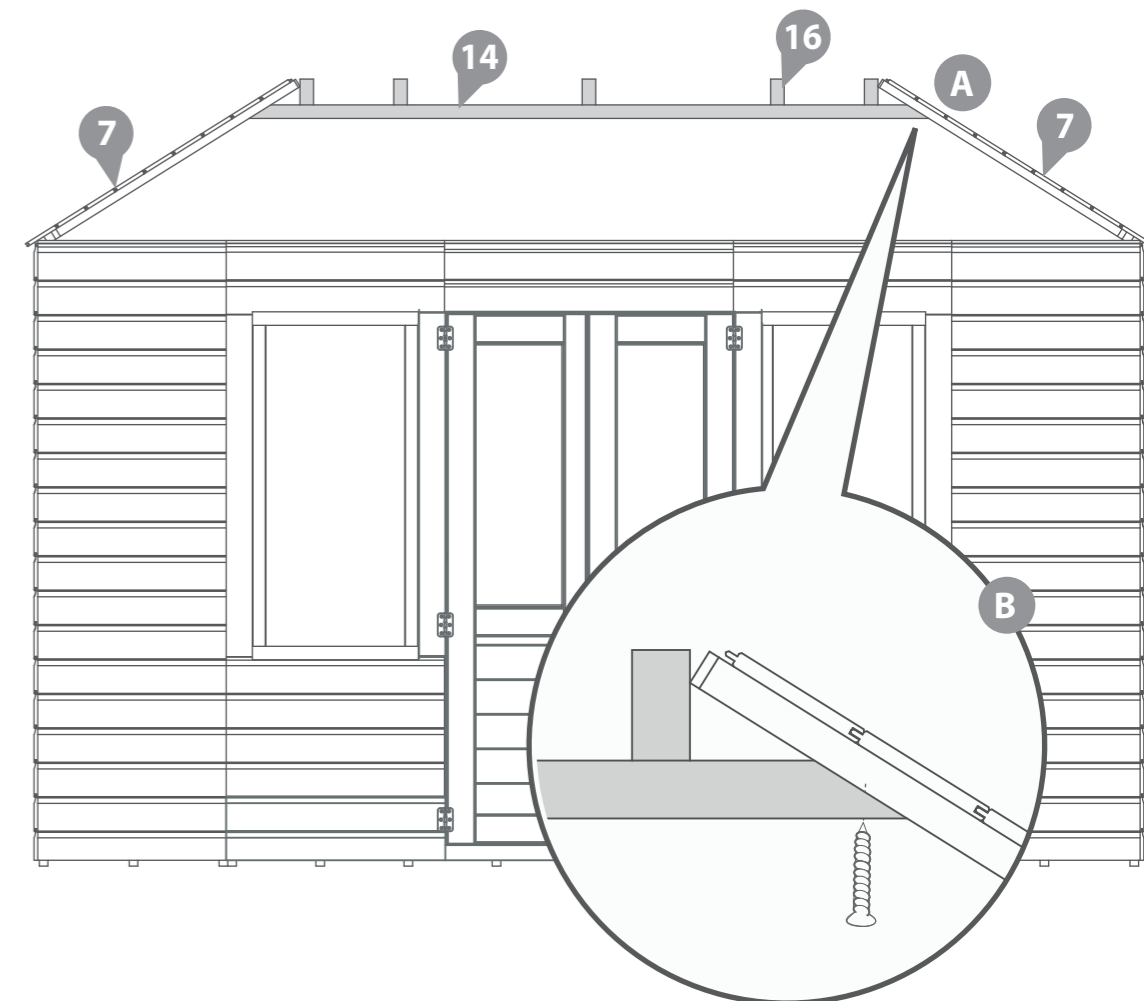
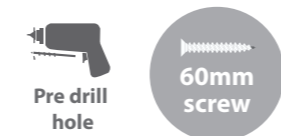

Step 21

**Parts needed - No. 8 QTY 1
No. 9 QTY 1
No. 10 QTY 1**

Place the remaining of roof panels (No. 8, 9 & 10) (previously assembled in Step 13) on to the Summer House using the same method mentioned in the previous step.

****Pull the corners together by the framing****

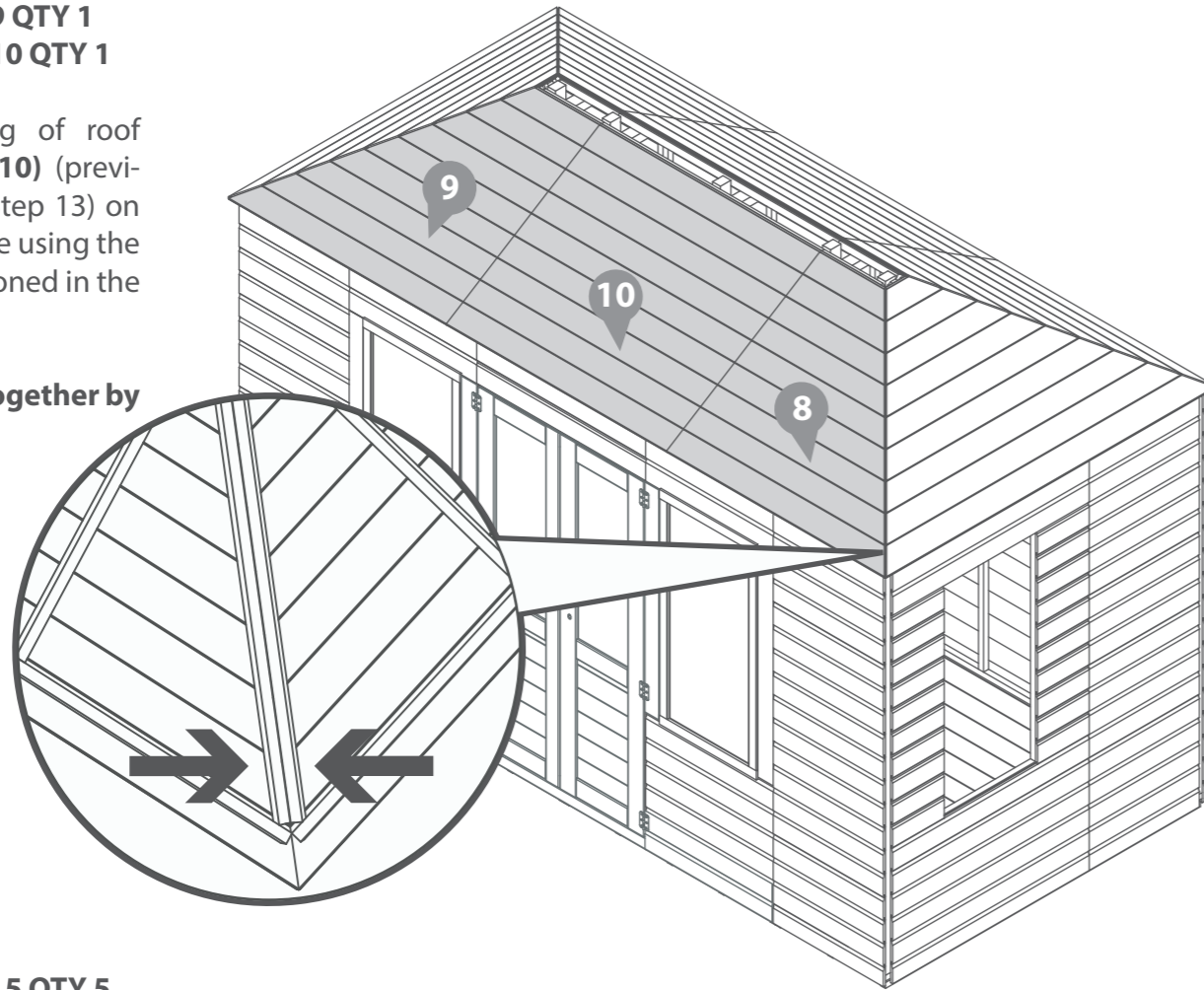

Step 22

Parts needed - No. 15 QTY 5

Secure the Roof bearer B's (No. 15) underneath Roof bearer A (No. 14) using 2x60mm screws per bearer through the previously drilled holes (in Step 15) up into the roof panels. Make sure that the Roof bearer B (No. 15) parts fit evenly under the framing of the roof panels and that the pointed corners meet the line that was drawn in a Step 16.

The underside of the roof should look as shown.

10x60mm Screws

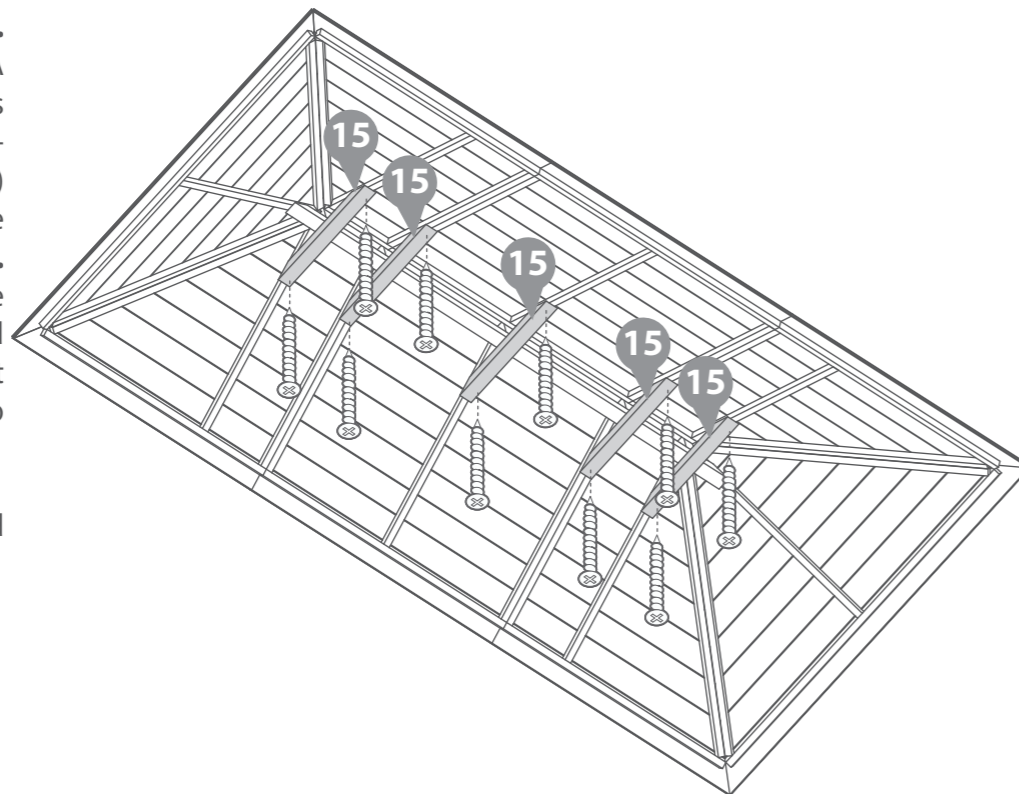

Step 23

A Once all four roof sides are on the building, pull the corners together and secure underneath the roof as shown. Fix using 3x50mm screws per join.

The Roof bearers may need to be unscrewed and repositioned to ensure all the roof panels sit level with each other.

***Roof panels will support each other if bearers are unscrewed.**

B Once the panels are secure, re-screw the bearers if necessary, and secure the five Roof Bearers B (No. 15) through their centres together with the Roof Bearer A using 5x70mm screw.

**12x50mm Screws
5x70mm Screws**

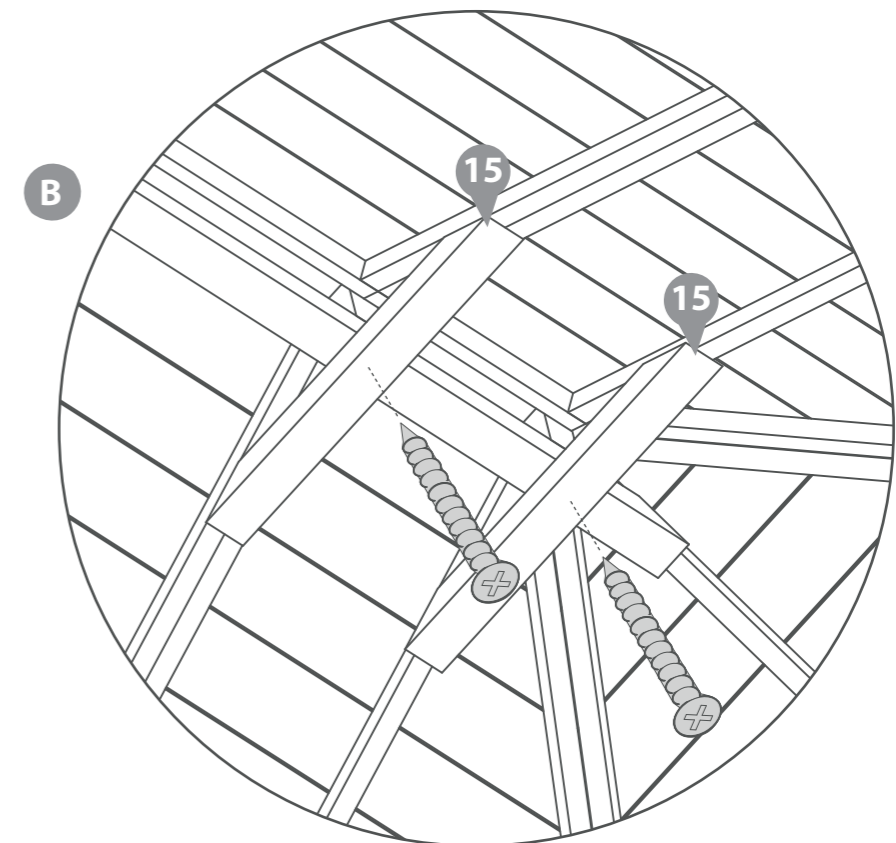
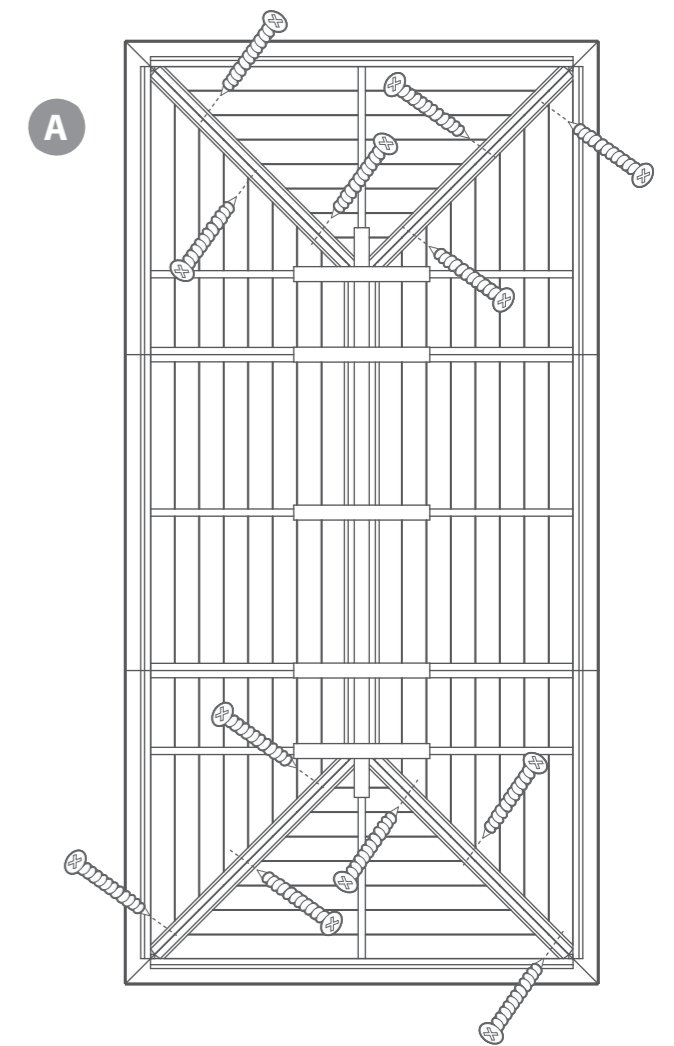

Step 24
Parts needed - No. 25 QTY 1

Attach the Flat Roof Strip (No. 25) to the top of the Summer House by screwing into each block below..

5x30mm Screws

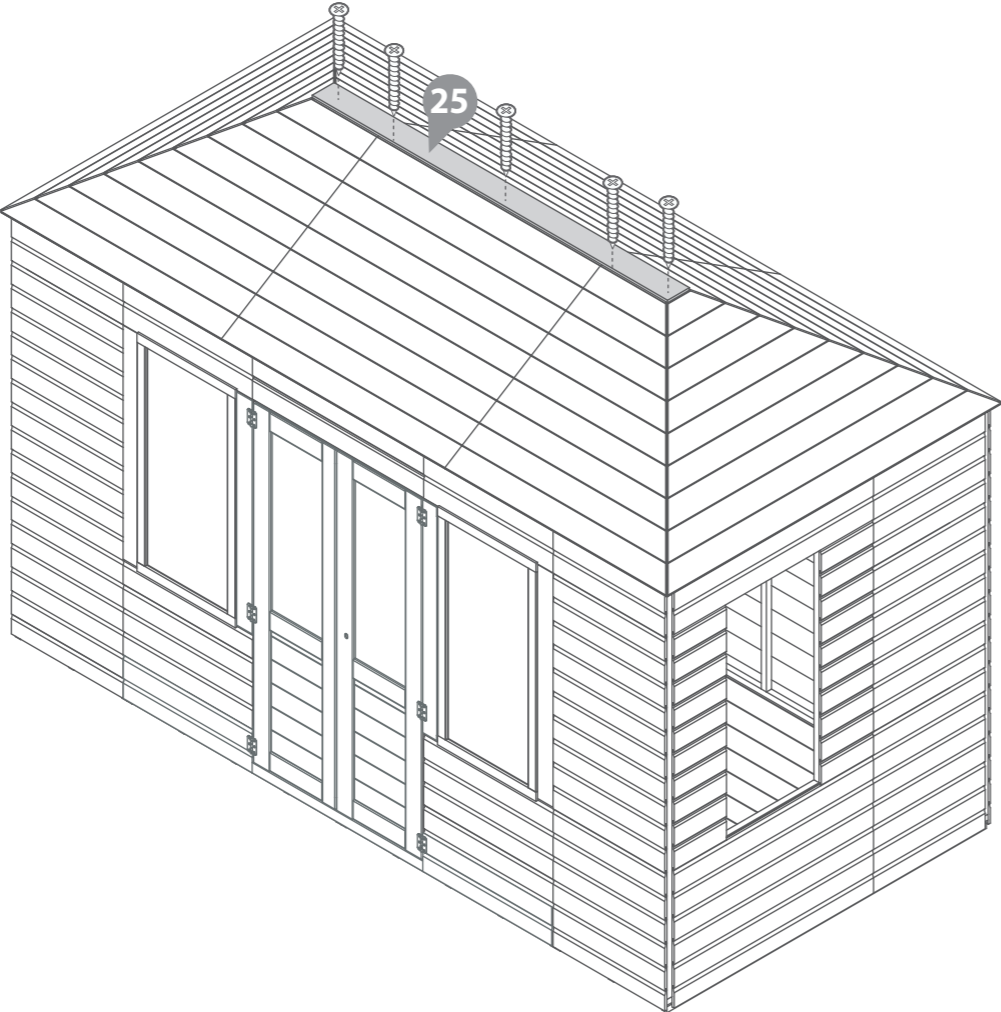

Step 26
Fix the roofs to the panels below by screwing down through the roofs into the panel framing below using 40mm screws.

28x40mm Screws

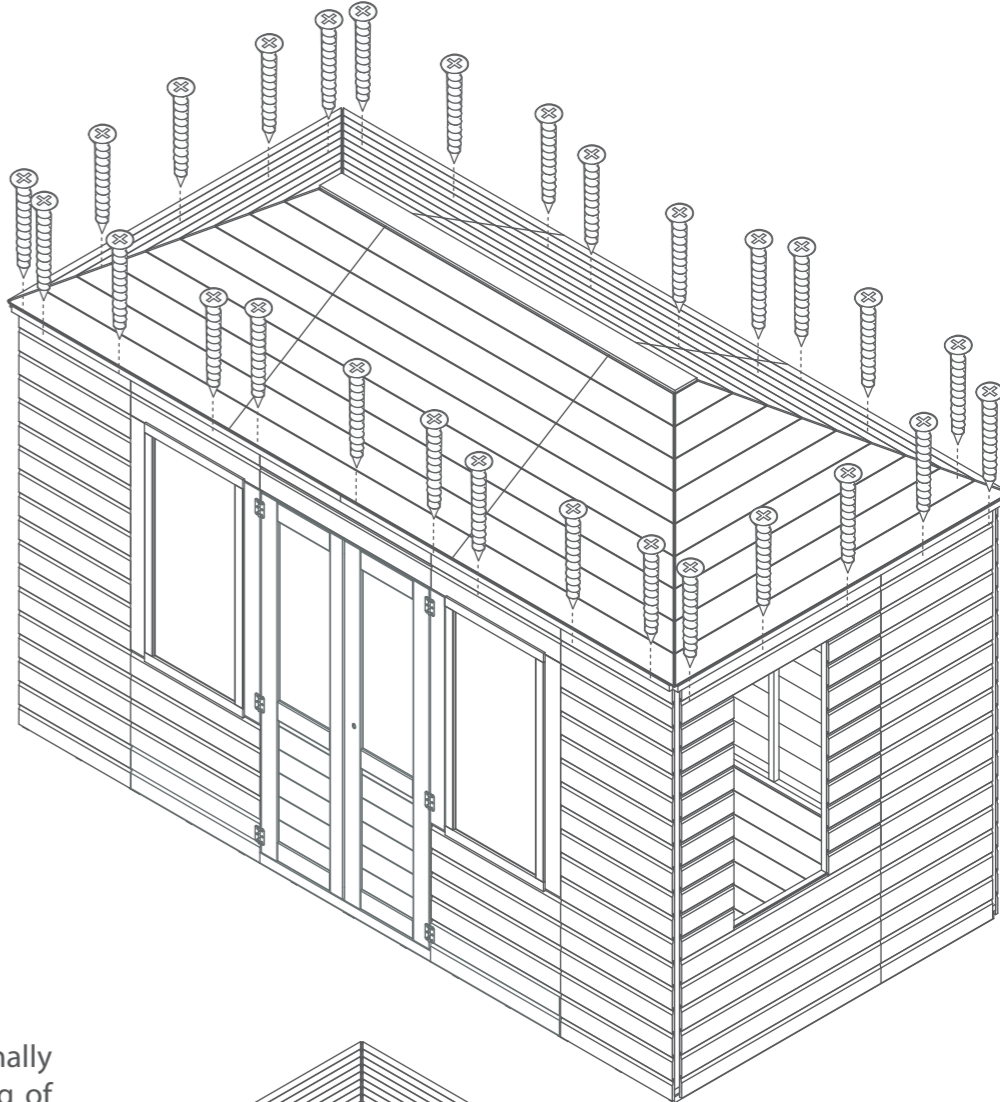

Step 25
Parts needed - No. 22 QTY 6

Fix each of the six Eaves frames (No. 22) to the walls touching the Roof with 4x 40mm screws in each piece of framing.

****Make sure that the screws go into the framing behind.**

24x40mm Screws

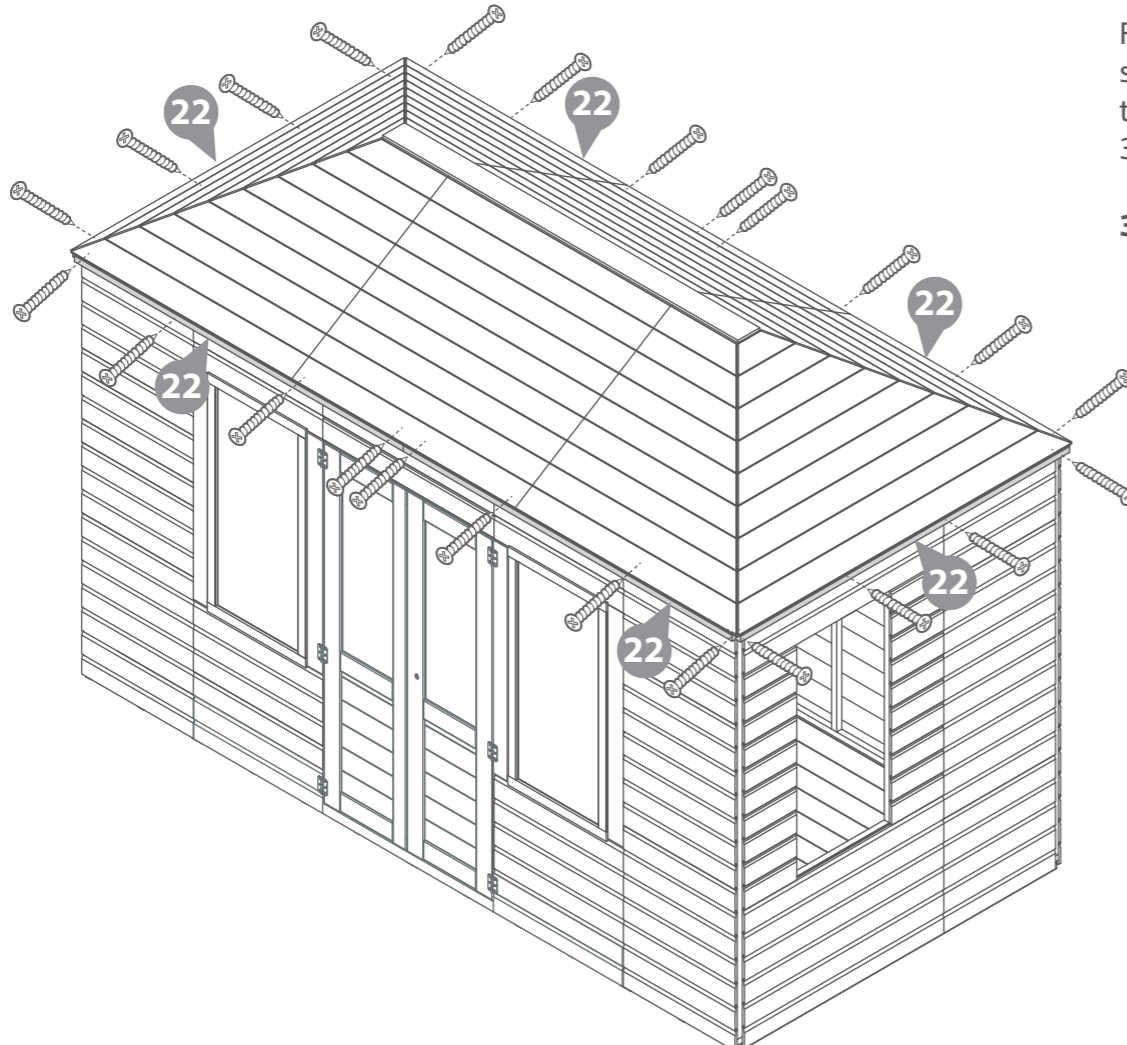
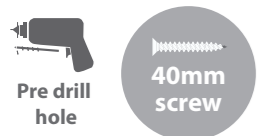

Step 27
Fix the building to the floor by internally screwing down through the framing of the panels into the floor framing using 33x50mm screws.

33x50mm Screws

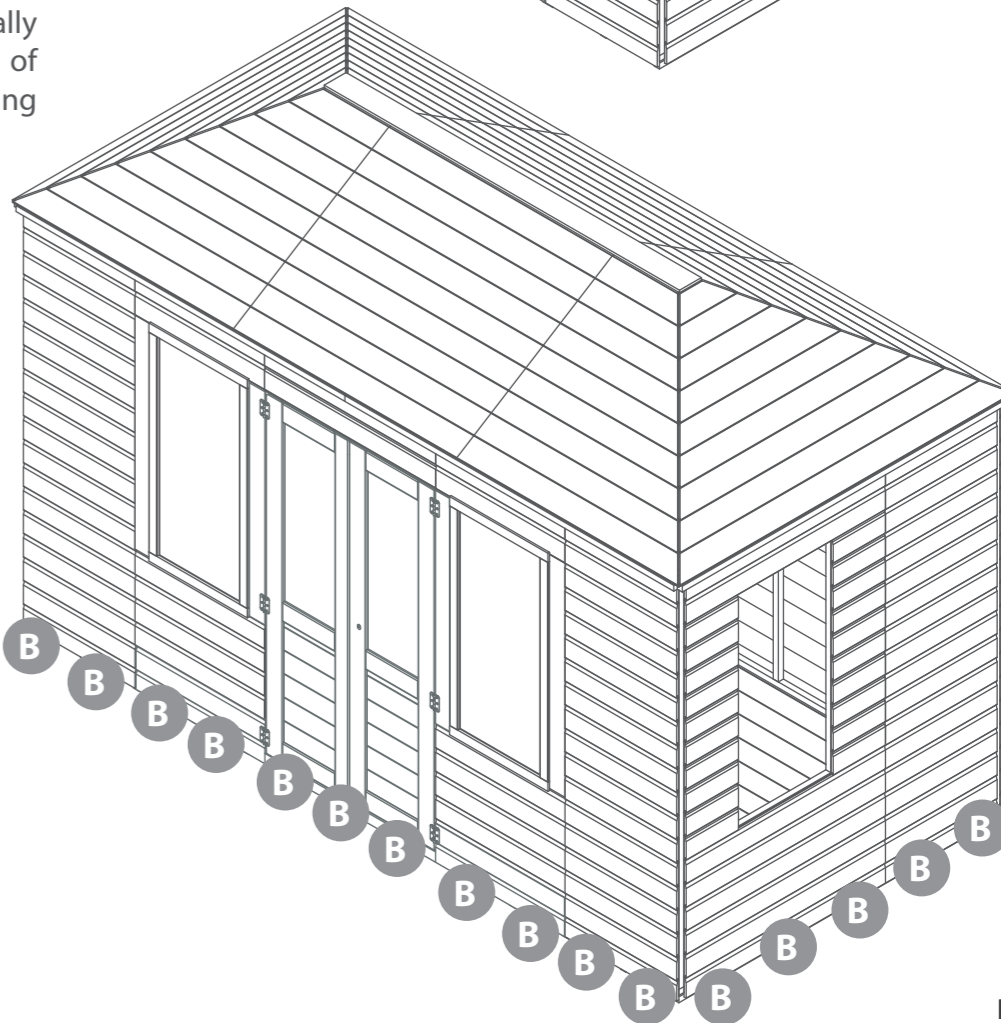
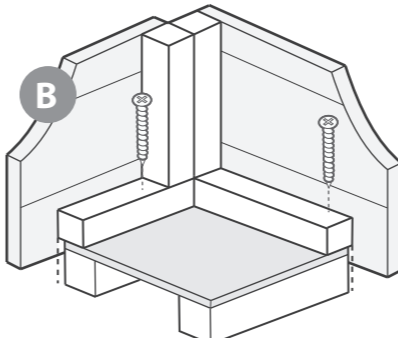
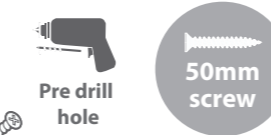

Step 28
Parts needed - No. 34 previously cut in to pieces in step 14.

A Position the four largest pieces of felt that you have cut (if you have not yet cut your felt please refer to Step 14) at the bottom of each side of the roof and fix with evenly spaced felt tacks. **Make sure the felt overhangs by 50mm. Trim as required.**

B Take the 2300mm long strip of felt cut in Step 14 and place it at the top of the roof and fix using felt tacks. **Make sure the felt overlaps by 50mm.**

C Using the four strips of felt cut in Step 14 place them over each of the ridges in the roof and fix using felt tacks, avoid felt tack already on the roof.

Secure all of the felt using felt tacks with even spaces of 100mm between each tack.

300x Felt tacks

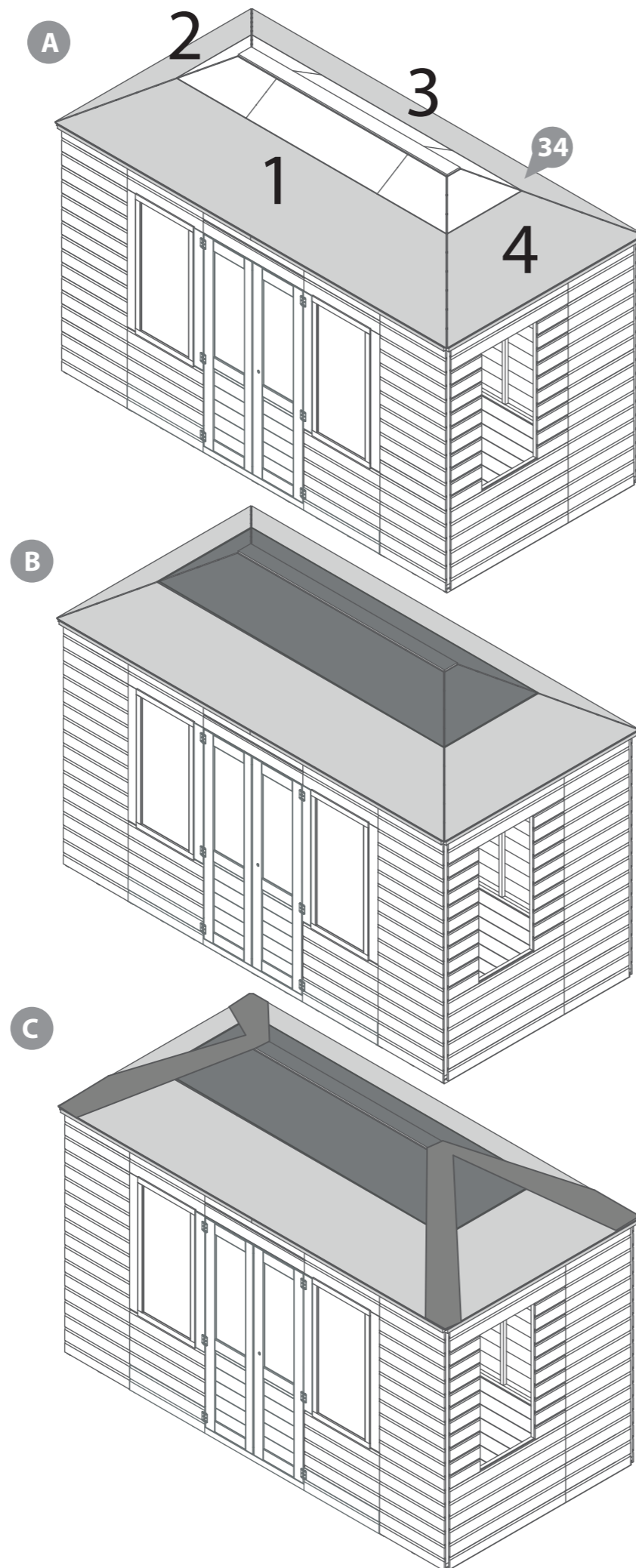

Step 29
Parts needed - No. 19 QTY 4
No. 20 QTY 2

Secure the Fascias (**No. 19 & 20**) to the building using 3 screws per piece.

The Fascias for the side of the building should be secured last and will need to be cut to length.

***Ensure to screw through the fascia into the eaves frame behind avoiding any other screws.**

24x30mm Screws

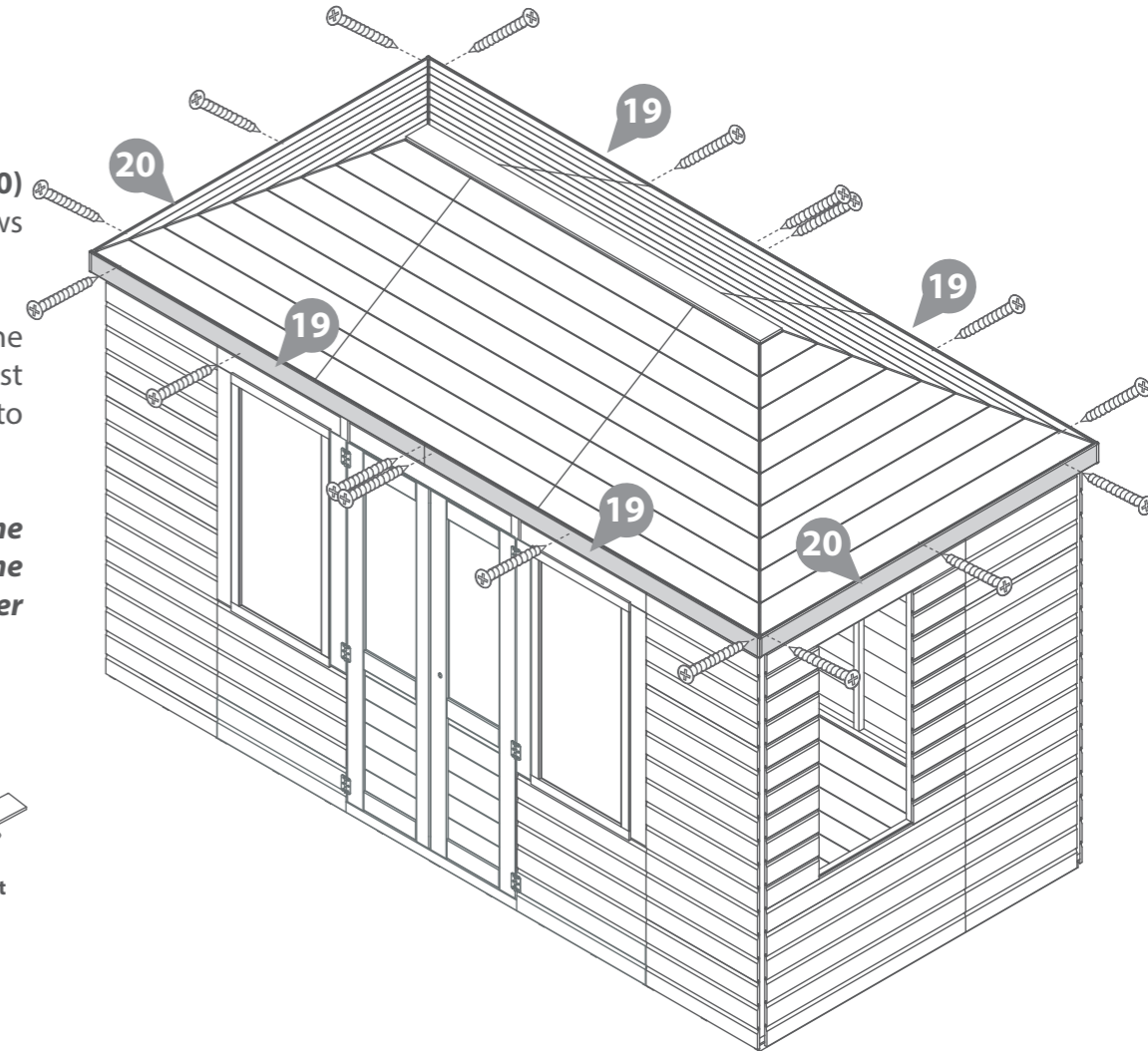

Step 30
Parts needed - No. 20 QTY 1
No. 33 QTY 2

Before fitting the Roof Cap Fascia and the Finials to the Summer House, secure from underneath the two Finials (**No. 33**) to either each end of the Roof Cap Fascia (**No. 20**) by using one 50mm screw per Finial.

2x50mm Screws

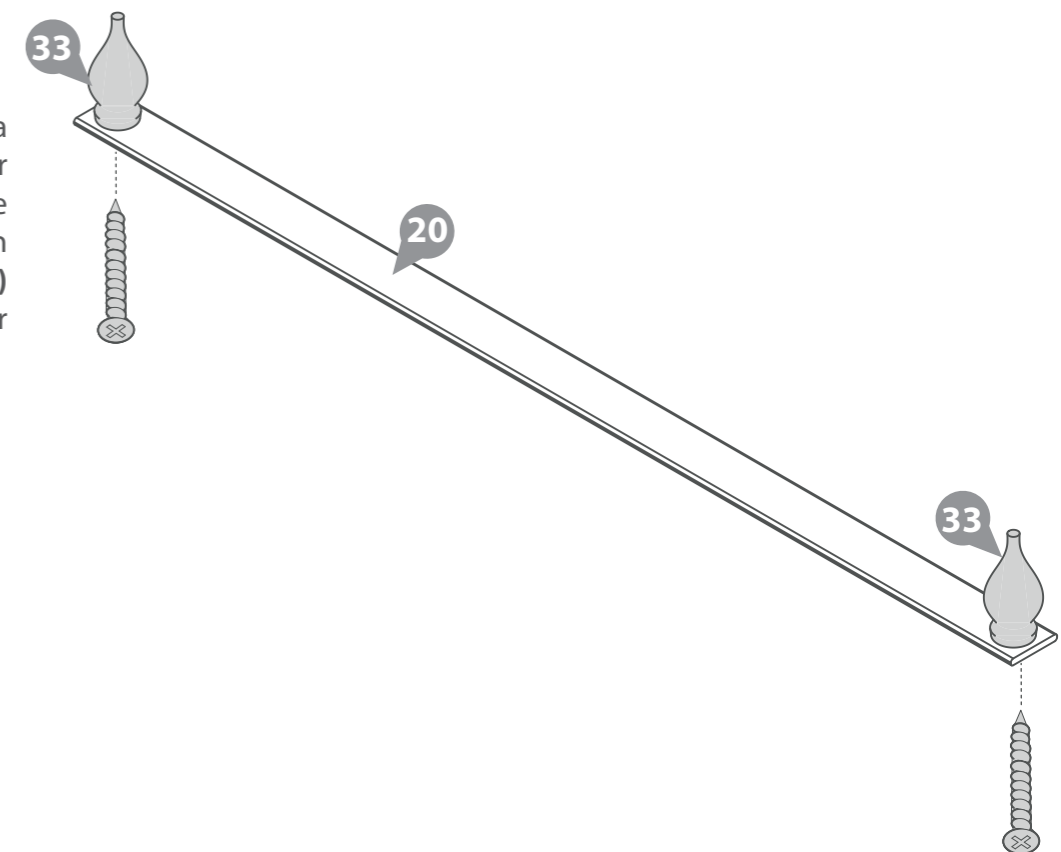

Step 31
Parts needed - No. 20 QTY 1
No. 33 QTY 2

Fix the already assembled (in Step 30) Finials (No. 33) and Roof Cap Fascia (No. 20) to the top of the Summer House using 5x30mm screws.

5x30mm Screws

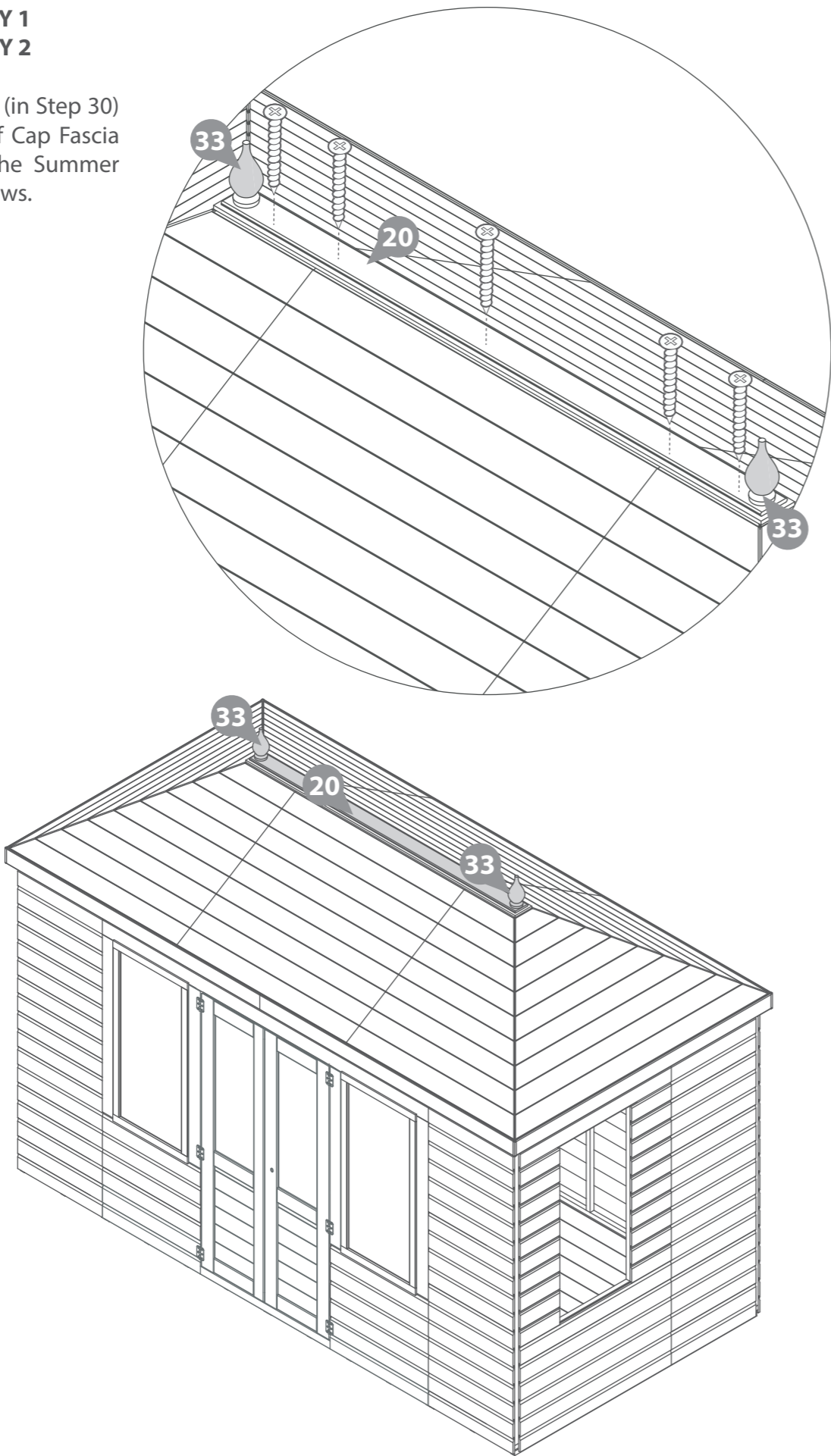
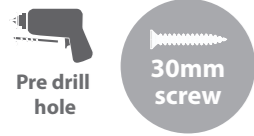

Step 32
Parts needed - No. 26 QTY 12

Fix the Cover Trims (No. 26) to each corner and over each joint of the building with 3x30mm screws per trim.

Take one of the Cover Trim and cut off two pieces and fit them over the joints above the door using 2x30mm screws per trim.

37x30mm Screws

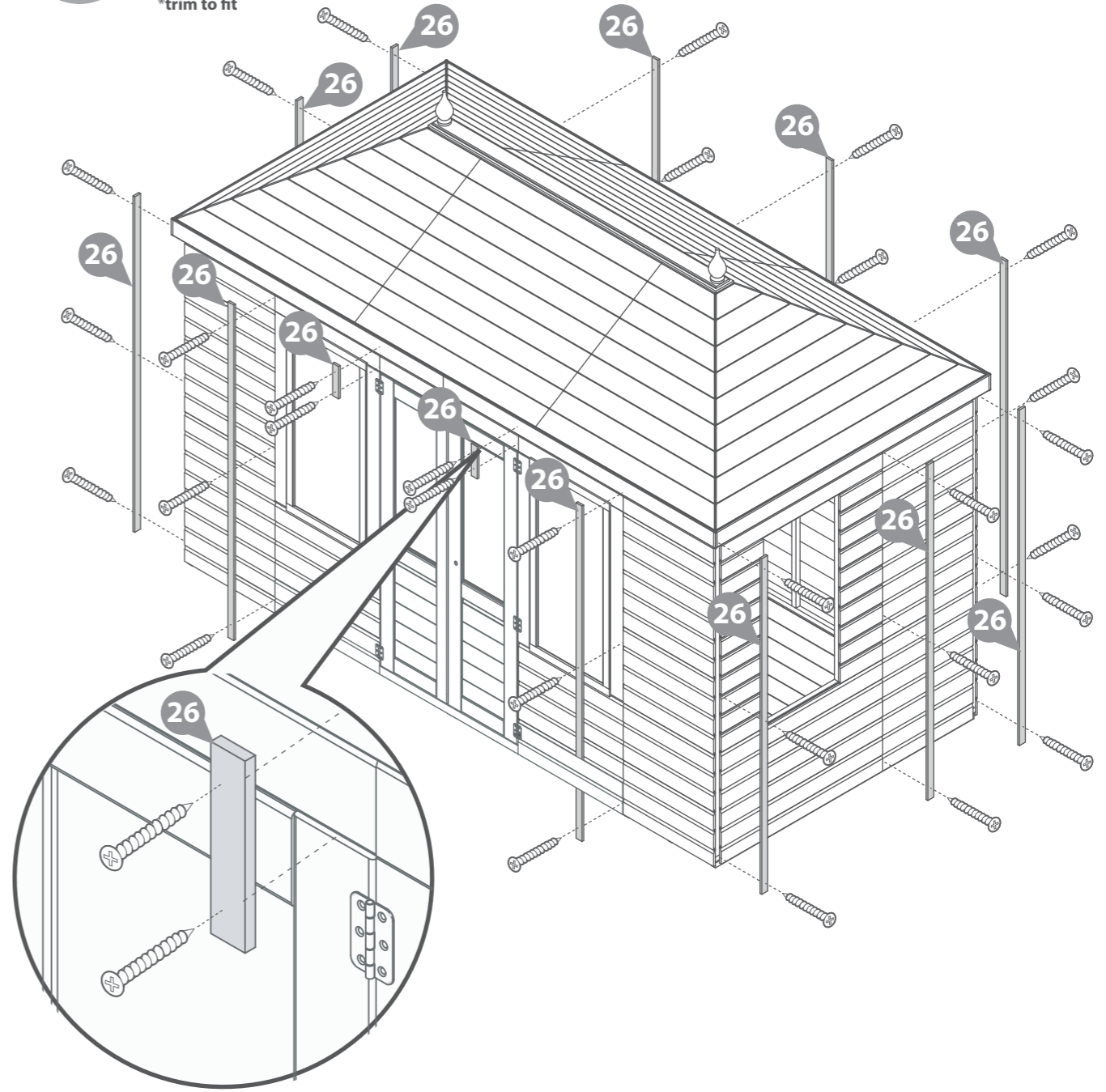
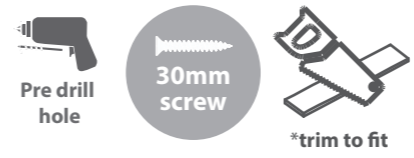

Step 33

Parts needed - No. 23 QTY 2

Fix the Window Strips (**No. 23**) to the top of each window opening on the side panels using 3x30mm screws.

****Make sure that the screws go into the framing behind.**

6x30mm Screws

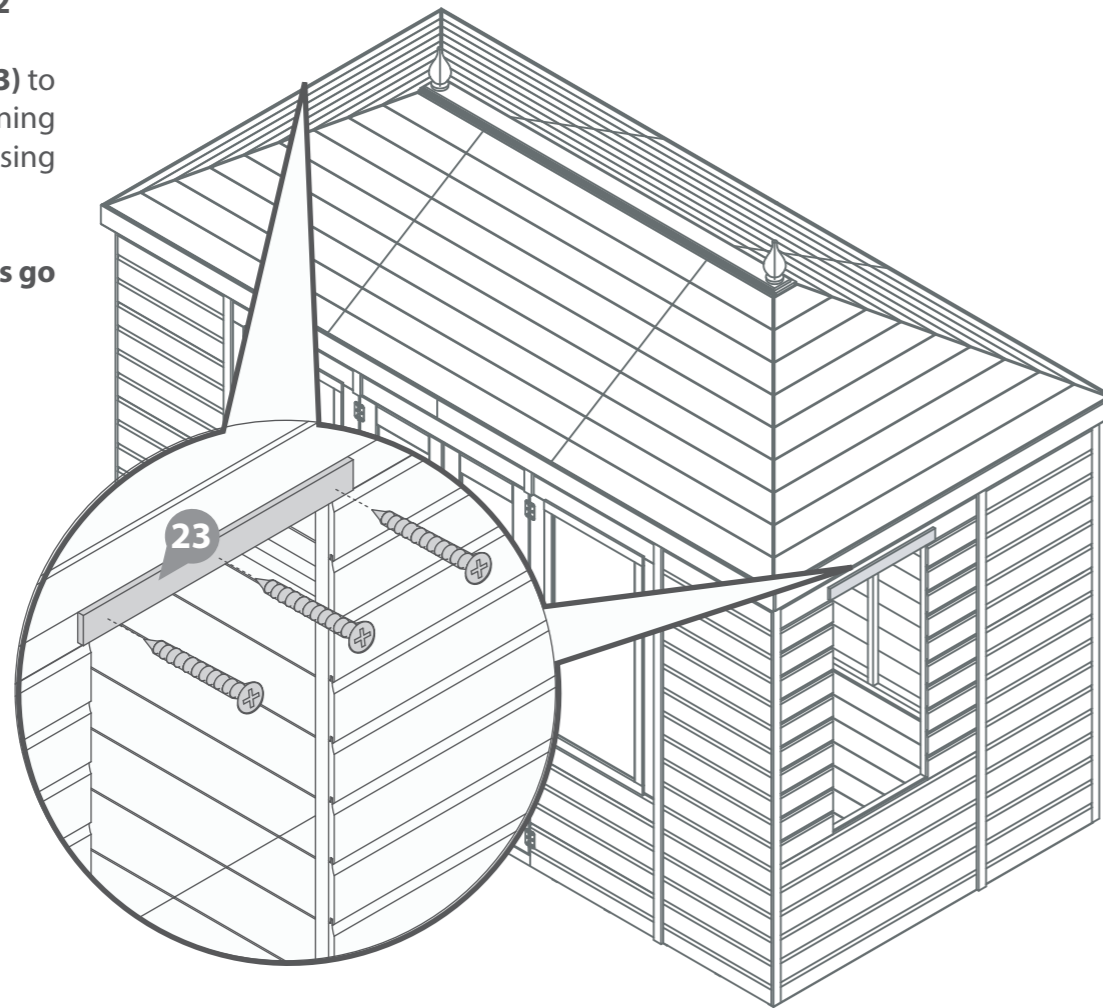

Step 34

**Parts needed - No. 31 QTY 4
No. 35 QTY 2**

Fix two Unequal Hinges (**No. 31**) to the Window Trims using 3x20mm screws per hinge.

Fit the Window (**No. 35**) into the opening and secure the hinges to the window using 2x20mm screws per hinge.

Repeat this step for both window sides of the building.

20x20mm Screws

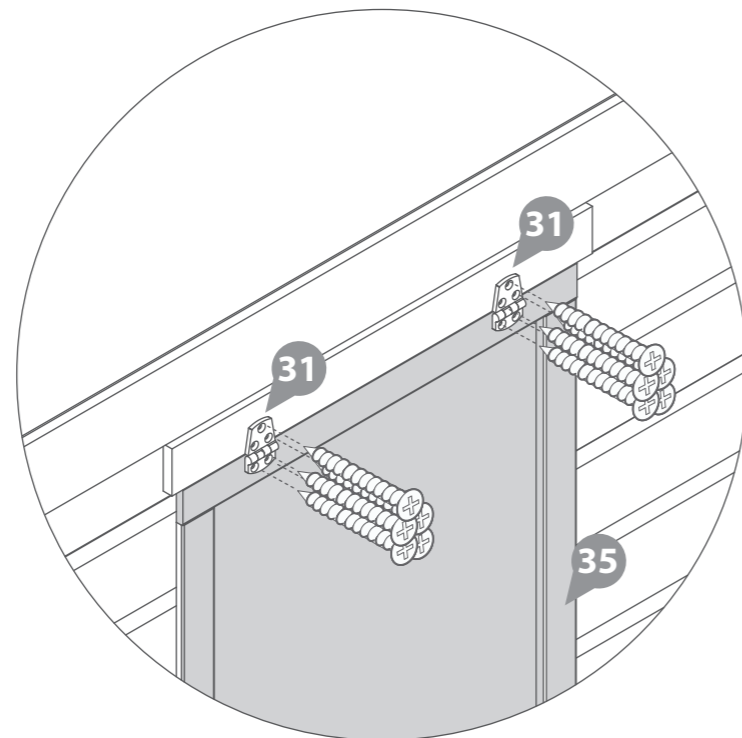

Step 35

**Parts needed - No. 29 QTY 1
No. 30 QTY 2**

A On the internal of the doors, fix the Tower Bolts (**No. 30**) at the top and bottom of the Secondary door using 4x20mm screws per bolt.

****Mark the position of the tower bolt with a pencil on the framing and drill a hole to site the bolts.**

B Fix the Press lock (**No. 29**) to the back of the Master door with 4x30mm screws. Making sure to align the key holes.

**8x20mm Screws
4x30mm Screws**

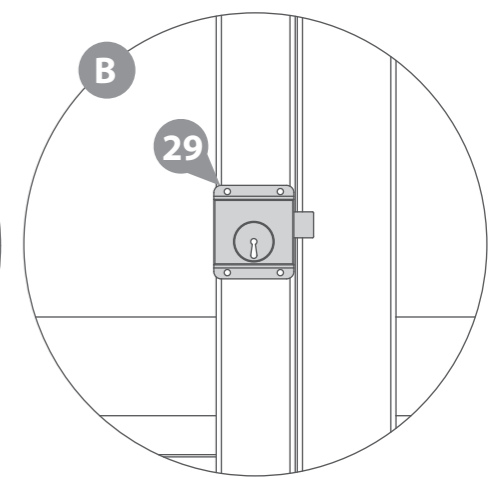
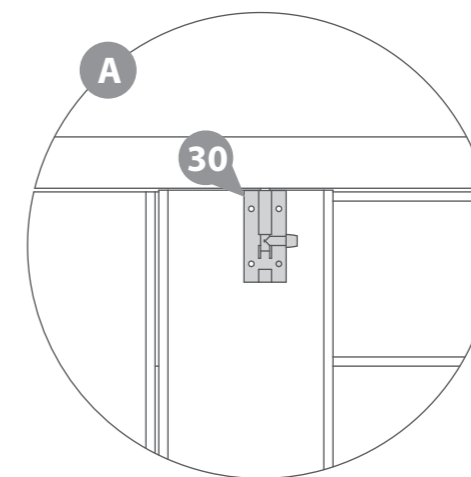
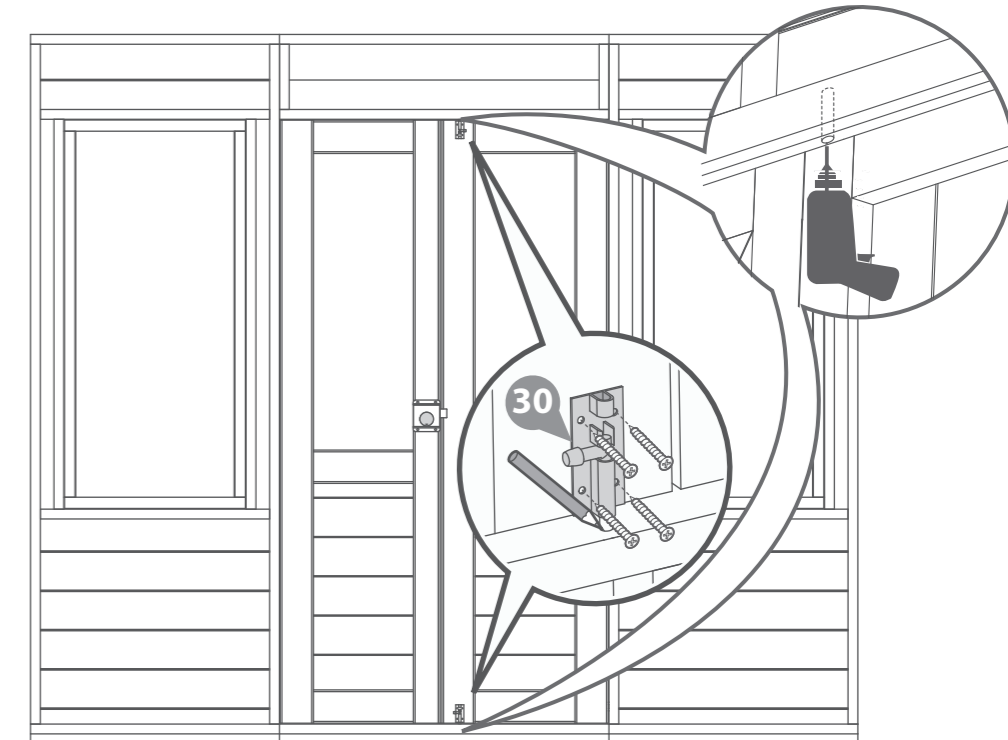

Step 36

Parts needed - No. 38 QTY 2

Attach the door handles (**No. 38**) to the doors using the 35mm bolts included with the door handle.

Pre drill a hole approximately 3mm and fix the handle from the inside with the provided bolts

4x35mm Bolt

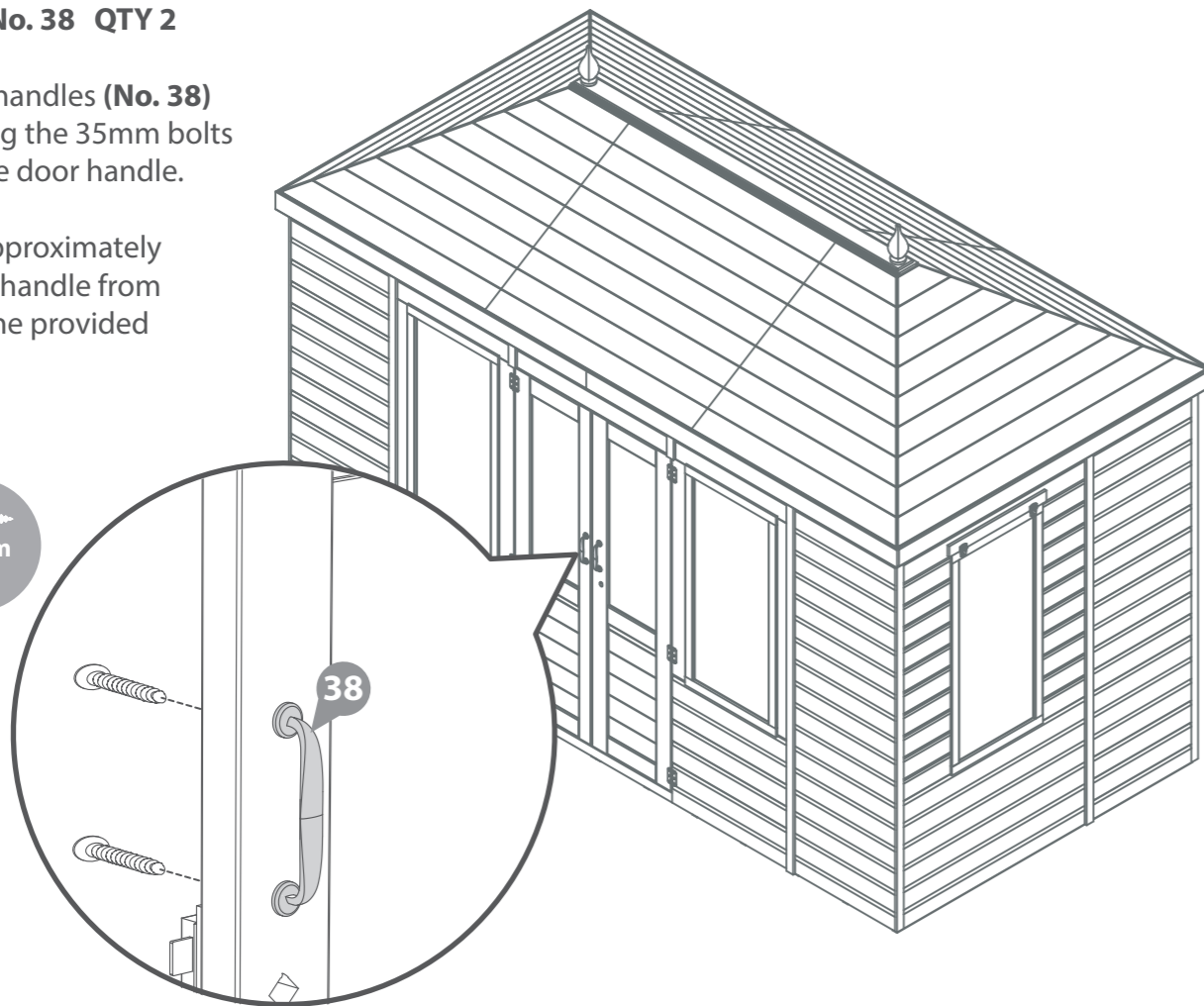
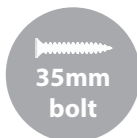

Step 38

Parts needed - No. 37 QTY 2

On the outside of the building fix the turn buttons (**No. 37**), to the top and bottom of the doors. Fix with 1x30mm screw per turn button.

2x30mm Screws

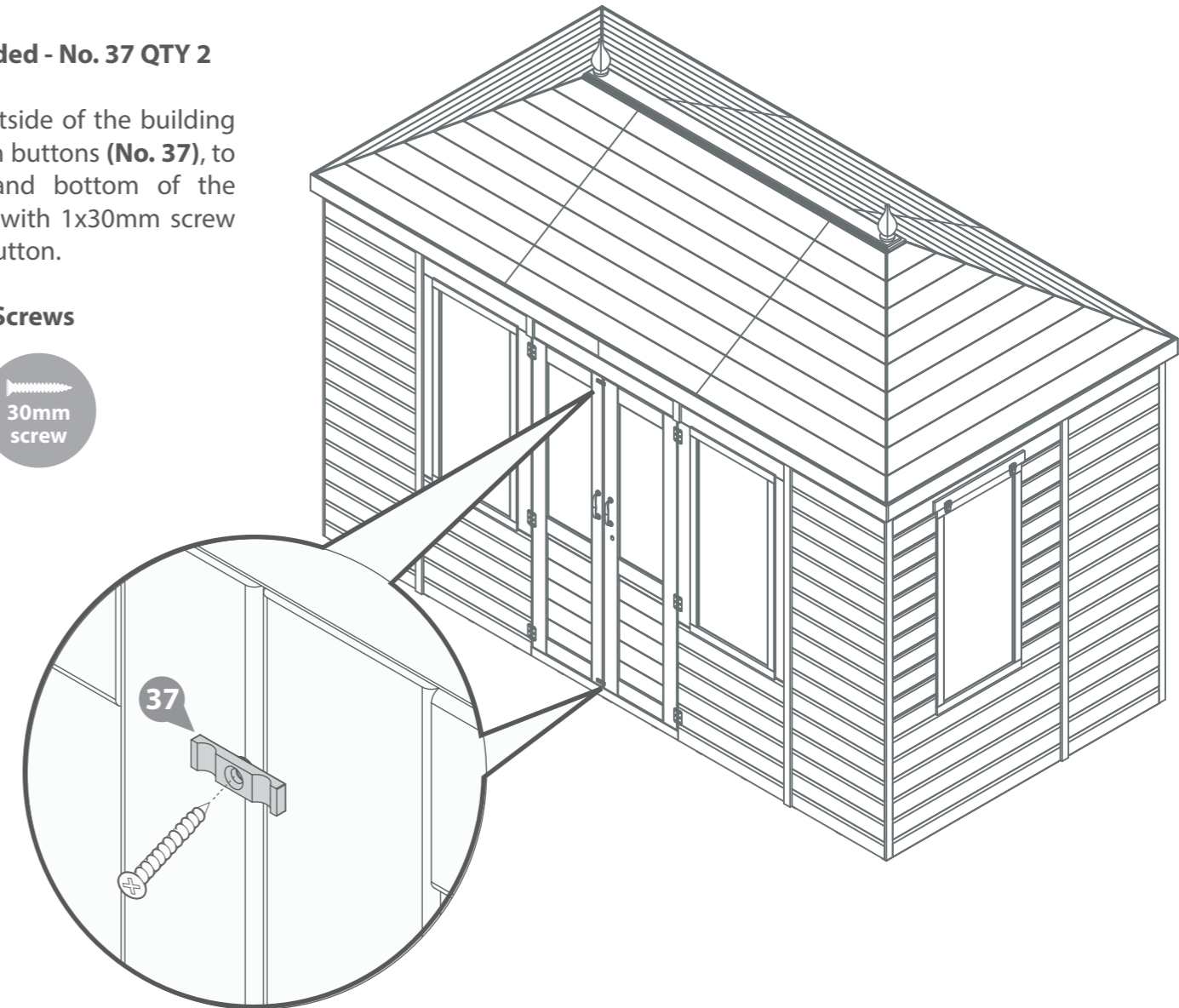

Step 37

**Parts needed - No. 27 QTY 2
No. 28 QTY 1**

On the inside of the building fix the Door Frame Strips (**No. 27 & 28**), to the top and sides of the doors frames. Make sure that the edges are flush with the framing. Fix with 4x30mm screws per strip.

12x30mm Screws

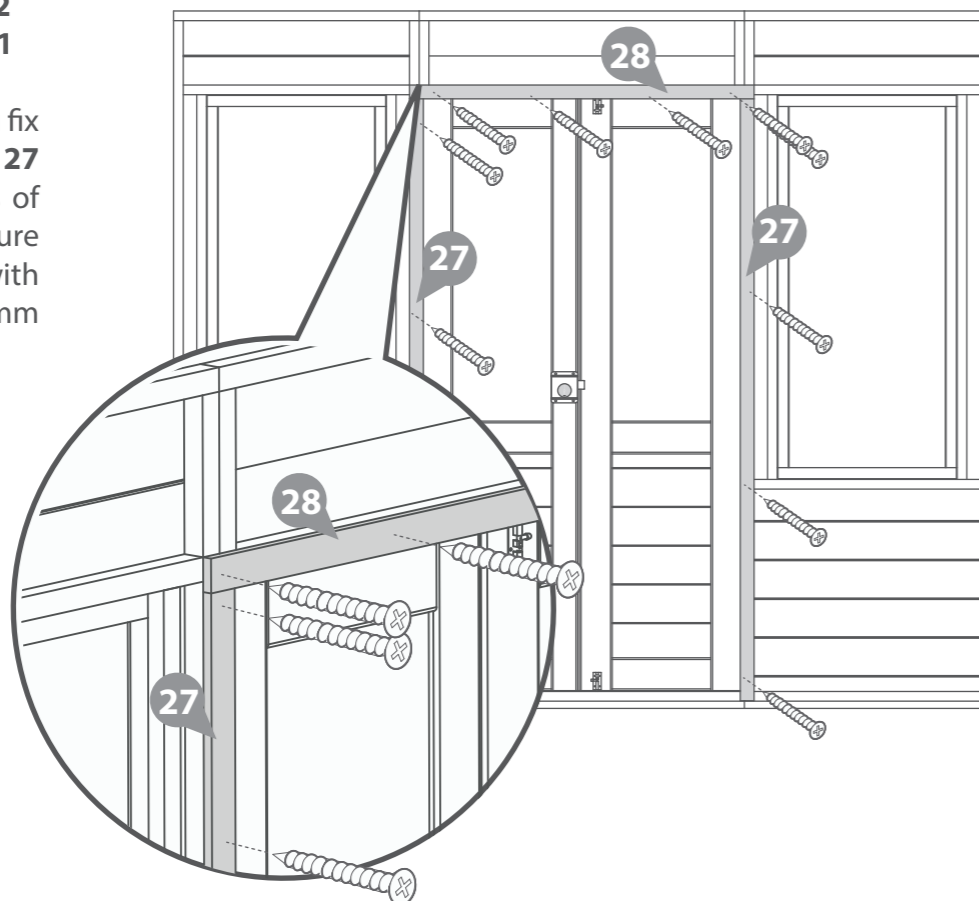

Step 39

Parts needed - No. 32 QTY 2

Fix the Casement Stay (**No. 32**) to each window using 2x20mm screws to attach to the window and 4x20mm screws to attach to the window framing.

12x20mm Screws

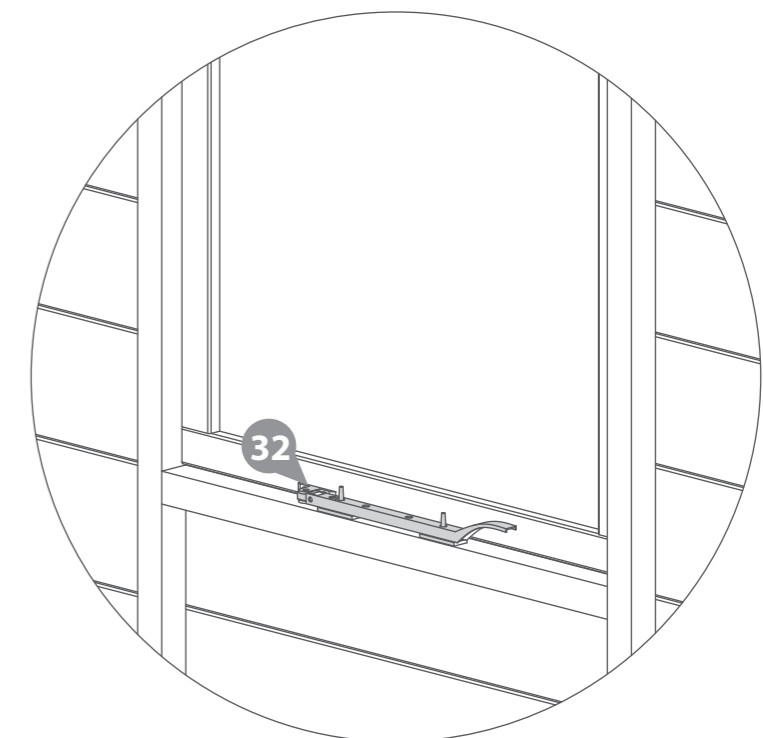
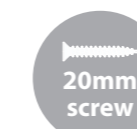

Step 40

**Parts needed - No. 17 QTY 4
No. 18 QTY 8**

Locate the Window Crosses (**No. 17 & No. 18**) into the windows.

Fix by screwing through the Cross into the Window framing using 6x20mm screws, as shown in the diagram.

Further secure the crosses by screwing 1x10mm screw at each meeting point, as shown in the diagram.

**24x20mm screws.
8x10mm screws**

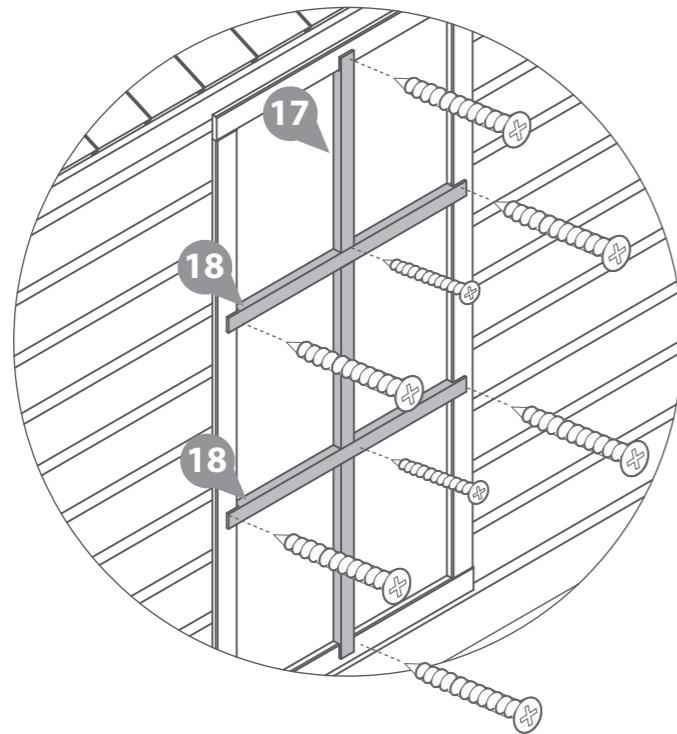
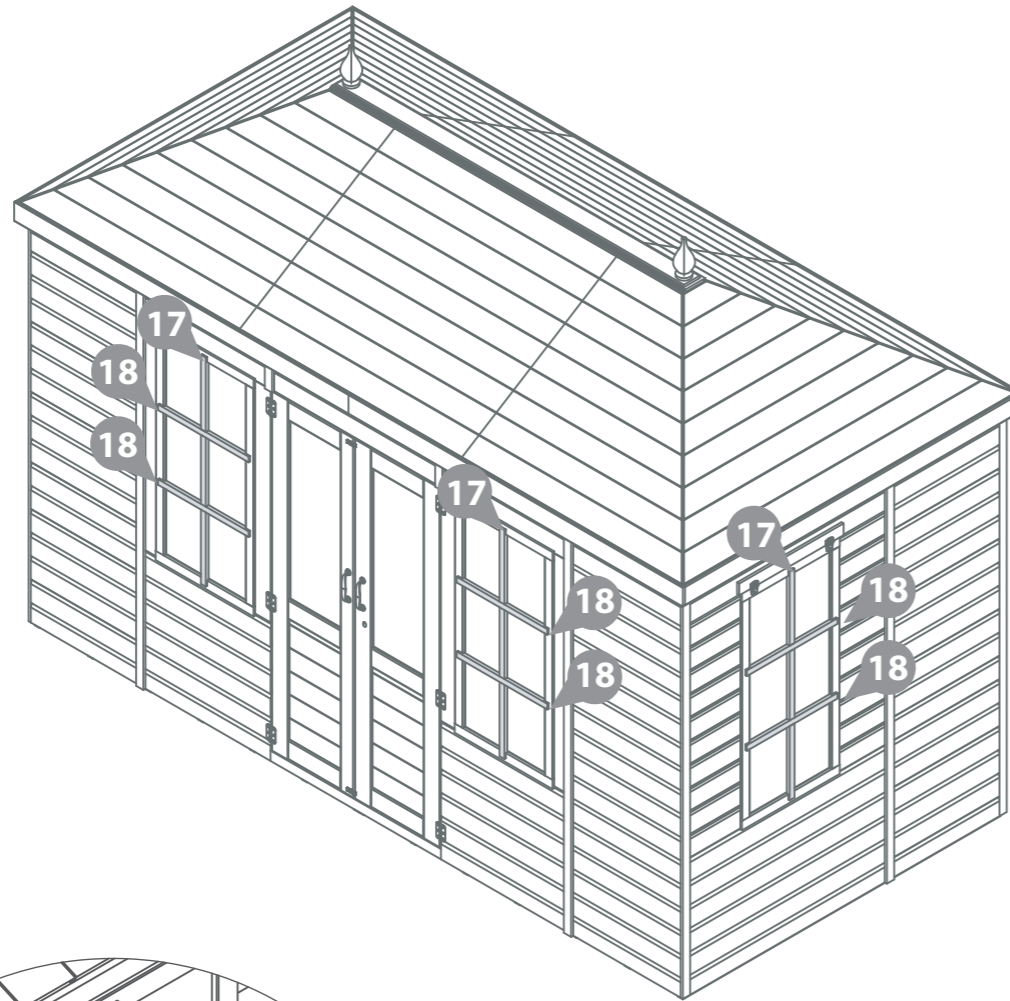

Pre drill hole



10mm screw



20mm screw

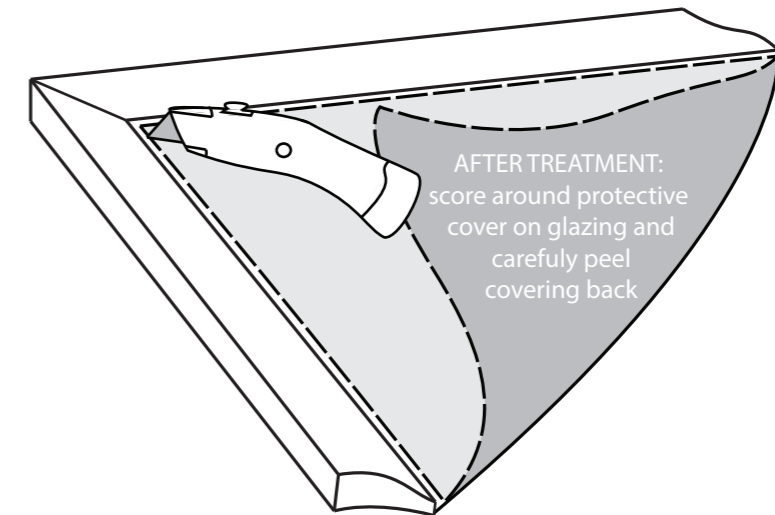

MANUFACTURER'S RECOMMENDATIONS

All our garden buildings have been designed and manufactured with care and attention to be the perfect addition to your outdoor space. To ensure you do get the best out of your new garden building and to increase the longevity we advise that you follow the product instructions and our manufacturer's recommendations as detailed below. Thank you for choosing a Mercia Garden product!

1 Choosing the most suitable location for your garden building...

A minimum of 60cm should be left around the perimeter of your garden building to allow access for maintenance, annual treatment and to allow air flow around the building.

Where possible you should avoid placing your garden building underneath large trees to prevent the tree causing damage to the building.

2 Preparing the base for your garden building...

All our buildings must be built on a firm, level base to ensure the longevity of the building and prevent the wood from distorting. We recommend either concrete, concrete slabs or a wooden base, such as our 'Portabase'.

The base should be slightly smaller than the external measurement of the building, i.e. the cladding should overlap the base, creating a run off for water and preventing water from pooling underneath the building.

We also recommend that the floor of the garden building is a minimum of 25mm above the surrounding ground level to avoid flooding.

3 After installation...

Once your garden building has been installed it will need to be treated as soon as possible and annually to prevent the timber from deteriorating and to waterproof it. This is required to maintain the anti-rot guarantee.

Dip Treated buildings - Require a preservative treatment to protect against rot and decay and a waterproof treatment to prevent water ingress

Pressure Treated buildings - Require a waterproof treatment to prevent water ingress

Log Cabins/Insulated Garden Rooms - Are supplied untreated and require a preservative and waterproofing treatment

We also recommend using a silicon sealant on the inside and outside of the windows as soon as possible after assembly and treatment to fully seal the windows.

Roofing felt/covering should be checked annually and replaced or fixed accordingly.

4 General maintenance and wood characteristics

As wood is a natural material it may be affected by the following:

Shrinkage and warping - The timber used in the construction of your garden building will have retained some of its natural moisture content. The moisture content of the timber will vary, depending upon prevailing environmental conditions, which will result in the components either naturally expanding or contracting. As the components dry out shrinkage may occur. A good waterproofing treatment from the start is the best protection to minimise the effect of moisture loss/intake.

In extended periods of very warm weather getting some moisture to the building will help the overall balance. You can do this by spraying it down lightly with a garden hose. In contrast after snow fall try to remove the snow as best as possible from the roof to prevent moisture intake and to remove the extra weight.

Top tip - using a garden brush will help you to reach the highest part of the building to remove snow and any debris left from bad weather.

Damp and mould - During the winter months, cold and damp conditions can result in an increased amount of moisture within your garden building, especially when used infrequently. Condensation can form on the timber and other items stored within your garden building. If left this moisture is likely to cause mould and mildew. To prevent the build-up of moisture, we recommend leaving the door or windows of your building open from time to time, to allow the fresh air to circulate. We also advise against storing wet or damp items in your garden building as this will also increase the level of moisture in the building. If mould or mildew does start to form within your building we recommend using an anti-mould cleaner to remove it and to prevent it spreading, which if left untreated could permanently damage your garden building.

Splits, cracks and knots - You may notice small splits and cracks in some components or holes may appear where knots shrink and fall out. This will not affect the structure of your Garden building however if you wish to fill them this can be easily done using any good quality wood filler.

Sap - is naturally occurring in wood and may appear in some boards of your garden building. If you wish to remove the sap, we advise waiting until it is dry and then using a sharp knife to carefully remove it. If the removal of the sap causes a hole in the timber, we recommend using a good quality wood filler to fill it.

For more handy hints and tips on how to care and maintain your garden building please refer to the MGP Customer Portal at www.mgplogistics.co.uk

Any further questions?

Contact our
Customer Service
Team on:
01636 821215

1 Manufacturer's Warranty

All Mercia Garden Products are supplied with a 1 year warranty on all parts against manufacturing defects.
This warranty does not cover movement, warping or splitting of timber products over time.

This warranty will be voided if any of the following occur:

1. The building has been customised or modified/adapted in any way.
2. The person claiming is not the original purchaser of the building.
3. Any damage has been caused by or as a result of misuse.
4. The building has not been maintained and cared for in accordance to our advisories and manufacturer's recommendations.
5. The building has not been treated annually or as per the manufacturer's recommendations, please ensure receipts are kept to validate this claim.
6. The building has not been erected, fitted or installed as per the supplier instructions.
7. The building has not been erected on a suitable sized firm flat, solid level concrete/slab base or placed on pressure treated bearers.
8. The building is or has been placed with 2 feet (60cm) of any obstructions (walls, trees, plants, fences etc.) which can allow moisture to penetrate the timber.
9. The roofing felt has been incorrectly fitted or damaged allowing water ingress, or not properly maintained.
10. Any windows and joints have not been sealed, inside and out, with silicone or other watertight sealant.
11. Any timber has been cut, pierced or drilled without subsequent application of approved cut-end treatment.

2 Anti-rot Guarantee

Mercia Garden Products offer a 10 year anti-rot guarantee on all dip treated (a preparatory treatment) and 15 years on all pressure treated products. This guarantee covers solid timber against rot, decay, blue stain and insect attack.

To validate the guarantee the building must be treated with a recognised wood preserver/water proof top coat (as detailed within manufacturer's recommendations) as soon as possible after assembly and annually thereafter.

This guarantee does not cover movement, warping or splitting of timber products over time.

This guarantee will be voided if any of the following occur:

1. The building has been customised or modified/adapted in any way.
2. The person claiming is not the original purchaser of the building.
3. Any damage is caused by or as a result of misuse.
4. The building has not been maintained and cared for in accordance to our advisories and manufacturer's recommendations.
5. The building has not been treated annually or as per the manufacturer's recommendations, please ensure receipts are kept to validate this claim.
6. The building has not been erected, fitted or installed as per the supplier instructions.
7. The building has not been erected on a suitable sized firm flat, solid level concrete/slab base or placed on pressure treated bearers.
8. The building is or has been placed with 2 feet (60cm) of any obstructions (walls, trees, plants, fences etc.) which can allow moisture to penetrate the timber.
9. The roofing felt has been incorrectly fitted or damaged allowing water ingress, or not properly maintained.
10. Any windows and joints have not been sealed, inside and out, with silicone or other watertight sealant.
11. Any timber has been cut, pierced or drilled without subsequent application of approved cut-end treatment.



REGISTER FOR YOUR
ANTI-ROT
GUARANTEE TODAY

PLEASE SCAN HERE:

