

10DTBARK0804-V1

The Berkshire Dog Run 8x4

BEFORE YOU START PLEASE READ INSTRUCTIONS CAREFULLY

- Check the pack and make sure you have all the parts listed.
- When you are ready to start, make sure you have the right tools at hand (not supplied) including a Phillips screwdriver, Stanley knife, Wood saw, Step ladder, Hammer and a Drill with 2mm bit.
- Ensure there is plenty of space and a clean dry area for assembly.

LOCATION FOR YOUR GARDEN BUILDING

A minimum of 60cm should be left around the perimeter of your garden building to allow access for maintenance, annual treatment and to allow air flow around the building.

Where possible you should avoid placing your garden building underneath large trees to prevent the tree causing damage to the building.

TIMBER

As with all natural materials, timber can be affected during various weather conditions. For the duration of heavy or extended periods of rain, swelling of the wood panels may occur. Warping of the wood may also occur during excessive dry spells due to an interior moisture loss. Unfortunately, these processes cannot be avoided but can be helped. It is suggested that the outdoor building is sprayed with water during extended periods of warm sunshine and sheltered as much as possible during rain or snow.

Once your garden building has been installed it will need to be treated as soon as possible and annually to prevent the timber from deteriorating and to waterproof it. This is required to maintain the anti-rot guarantee.

Dip Treated buildings - Require a preservative treatment to protect against rot and decay and a waterproof treatment to prevent water ingress

Pressure Treated buildings - Require a waterproof treatment to prevent water ingress

Log Cabins - Are supplied untreated and require a preservative and waterproofing treatment.

BUILDING A BASE

When thinking about where the building and base is going to be constructed:
Ensure that there will be access to all sides for maintenance work and annual treatment.

Ensure the base is level and is built on firm ground, to prevent distortion. Refer to diagrams for the base dimensions, The base should be slightly smaller than the external measurement of the building, i.e. The cladding should overlap the base, creating a run off for water. It is also recommended that the floor be at least 25mm above the surrounding ground level to avoid flooding.

TYPES OF BASE

- Concrete 75mm laid on top of 75mm hard-core.
- Slabs laid on 50mm of sharp sand.

Whilst all products manufactured are made to the highest standards of Safety and in the case of childrens products independently tested to EN71 level, we cannot accept responsibility for your safety whilst erecting or using this product.

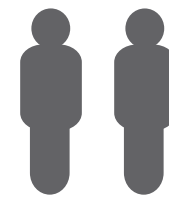

x2

All buildings should be erected by two adults



Winter = High Moisture = Expansion
Summer = Low Moisture = Contraction



2mm Drill bit

For ease of assembly, you **MUST** pilot drill all screw holes and ensure all screw heads are countersunk.



CAUTION

Every effort has been made during the manufacturing process to eliminate the prospect of splinters on rough surfaces of the timber. You are strongly advised to wear gloves when working with or handling rough sawn timber.



For ease of assembly, you will need a tape measure to check dimensions of components.

****Protim Aquatan T5 (621)****

Your building has been dip treated with **Aquatan**.

Aquatan is a water-based concentrate which is diluted with water, the building has been treated by the correct application of Aquatan solution and then allowed to dry.

Aquatan is a decorative finish to colour the wood, which is applied industrially to timber fence panels and garden buildings.

Aquatan undiluted contains: boric acid, sodium hydroxide 32% solution, aqueous mixture of sodium dioctyl sulphosuccinat and alcohols: 2, 4, 6-trichlorophenol.



REGISTER FOR YOUR
ANTI-ROT
GUARANTEE TODAY

PLEASE SCAN HERE:

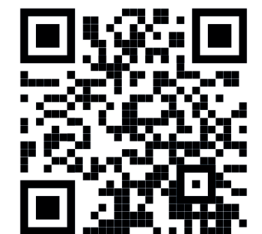

For assistance please contact customer care on: 01636 821215

Mercia Garden Products Limited,

Sutton On Trent,

Newark,

Nottinghamshire,

NG23 6QN

www.merciagardenproducts.co.uk

10DTBARK0804-V1

Please retain product label and instructions for future reference

8x4 Overall Dimensions: Width = 2330mm Depth = 1252mm Height = 1256mm	10x4 Overall Dimensions: Width = 2896mm Depth = 1252mm Height = 1256mm	12x4 Overall Dimensions: Width = 3483mm Depth = 1252mm Height = 1256mm
Base Dimensions: Width = 2258mm Depth = 1126mm	Base Dimensions: Width = 2823mm Depth = 1126mm	Base Dimensions: Width = 3388mm Depth = 1126mm

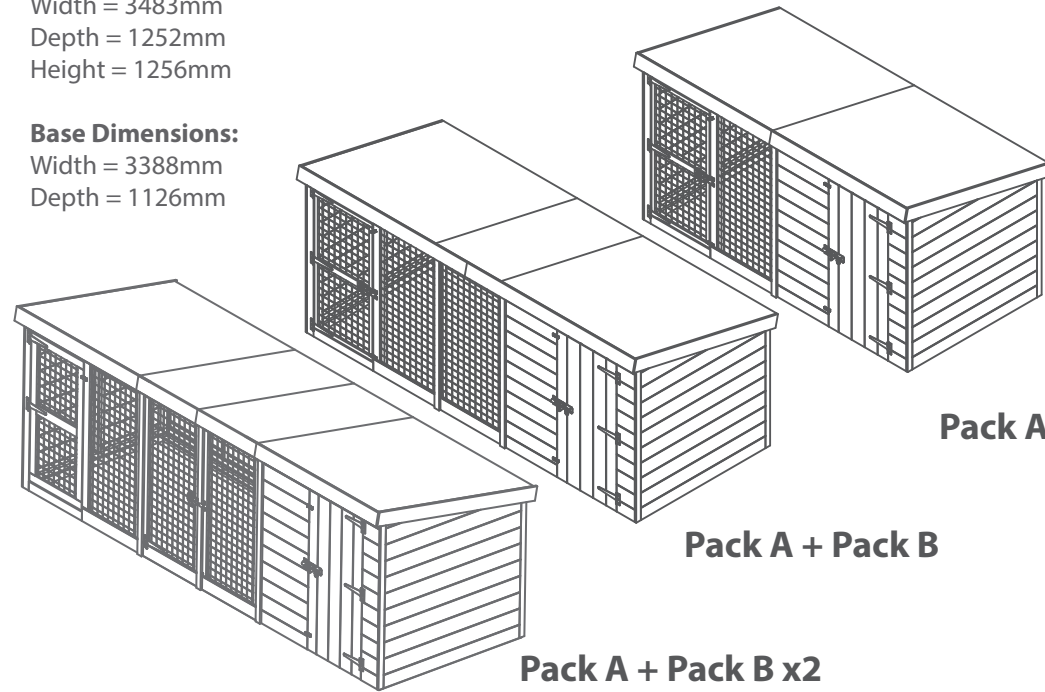

Pack A

Pack A + Pack B

Pack A + Pack B x2

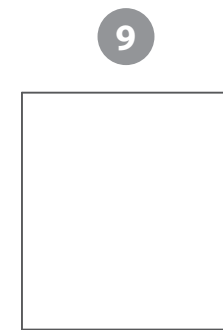

OSB A
PI-03-0352
QTY - 8x4 -2
10x4 -2
12x4 -3

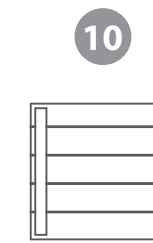

Floor Tile
AI-10BARK548X535-V1F
QTY x4

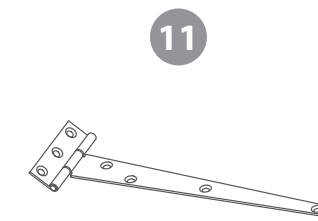

T-hinge
PI-07-0082
QTY x6

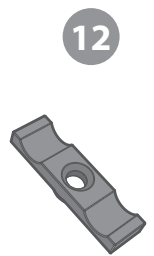

Turn button
PI-07-0034
QTY x4

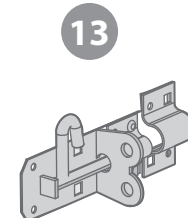

Pad bolt
PI-07-0035
QTY x2



Fascia - 12x95x1270mm S1295-1250mm x4



Cover Trim - 12x40x1218mm S1240-1218mm x6



Eaves Frame - 28x28x1153mm FS2828-1153mm x4



Base Frame A- 44x44x1126mm F4444-1126mm x3



Base Frame B- 44x44x1066mm F4444-1066mm



Base Frame C- 44x44x519mm F4444-519mm QTY x2



Base Frame D- 44x44x1060mm F4444-1060mm



Centre Framing- 28x28x1085mm
FS2828-1085mm



Before assembly please make sure you have a suitable base ready to erect your building

1

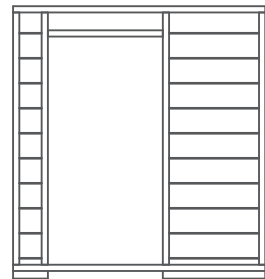

Door Panel
AI-10BARK1130X1220-V1DP

2

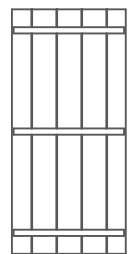

Door
AI-10BARK510X1095-V1D

3

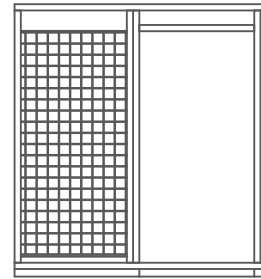

Run Door Panel
AI-10BARK1130X1220-V1RP

4

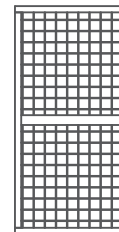

Mesh Door
AI-10BARK499X1021-V1MD

5

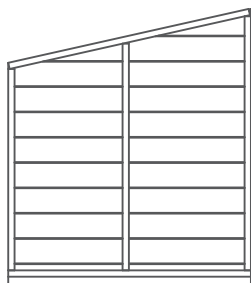

Right Gable
AI-10BARK1074X1218-V1RG

6

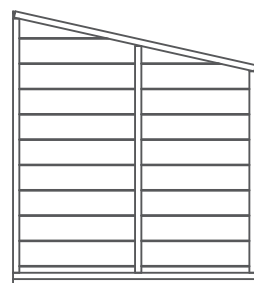

Left Gable
AI-10BARK1074X1218-V1LG

7

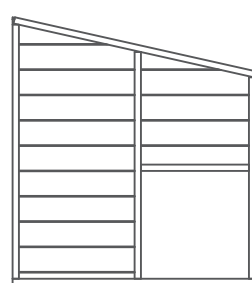

Centre Gable
AI-10BARK1074X1218-V1CG

8

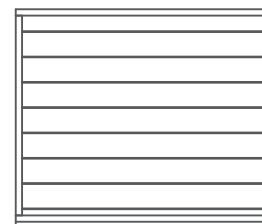

Back Panel
AI-10BARK1130X974-V1BP
QTY-2

Pack B

If you have purchased a 12x4 building then you will have double the amount of each item in pack B

22



Small Back Panel
AI-10BARK564X974-V1SBP
QTY - 1

23

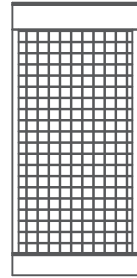

Mesh Panel
AI-10BARK565X1220-V1MP
QTY - 1

24



OSB B
PI-03-0353
QTY - 1

25



Cover Trim - 12x40x1218mm 1240-1218mm QTYx2

26

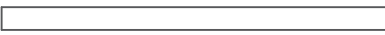

Roof support - 27x44x1085mm 2744-1085mm

27



Roof Block - 27x44x100mm 2744-100mm QTYx2

28

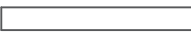

Eaves Frame B - 28x28x565mm 2828-565mm QTYx2

29

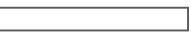

Framing - 44x44x563mm 4444-563mm QTYx2

30



Framing - 28x28x1623mm 2828-1623mm

31



Strip - 12x95x565mm 1295-565mm

Nail Bag



70mm Screw x25



30mm Screw x198



50mm Screw x76



20mm Screw x44



40mm Screw x98



Felt Tacks x105

Pre Assembly

Remove the transportation blocks from the bottom of each panel before assembling the building.

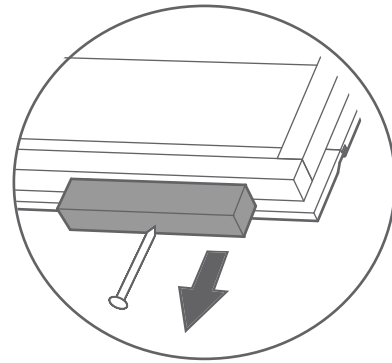

Step 2

Place the Right Gable (No. 5) and the Back Panel (No. 8) onto the the base framing and fix together with 3x40mm screws.

****Do NOT fix to the base framing until the Roof is secured****

3x40mm screws.

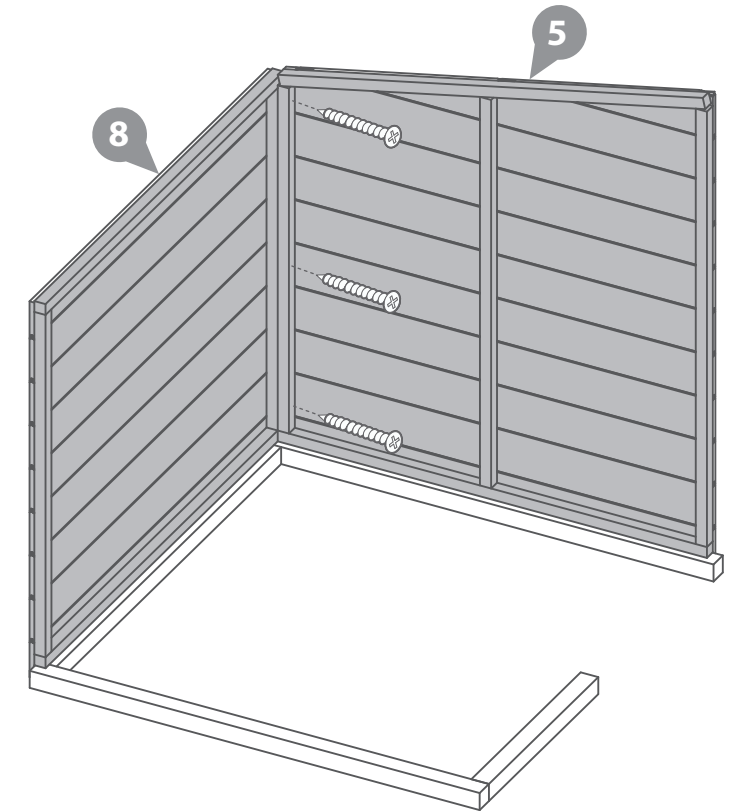

Step 1

Construct the Base using Base Framing A (No. 17) B (No. 18) & C (No. 19) This will create a base for the Kennel area.

Fix the Framing together with 2x70mm screws per corner.

6x70mm screws.

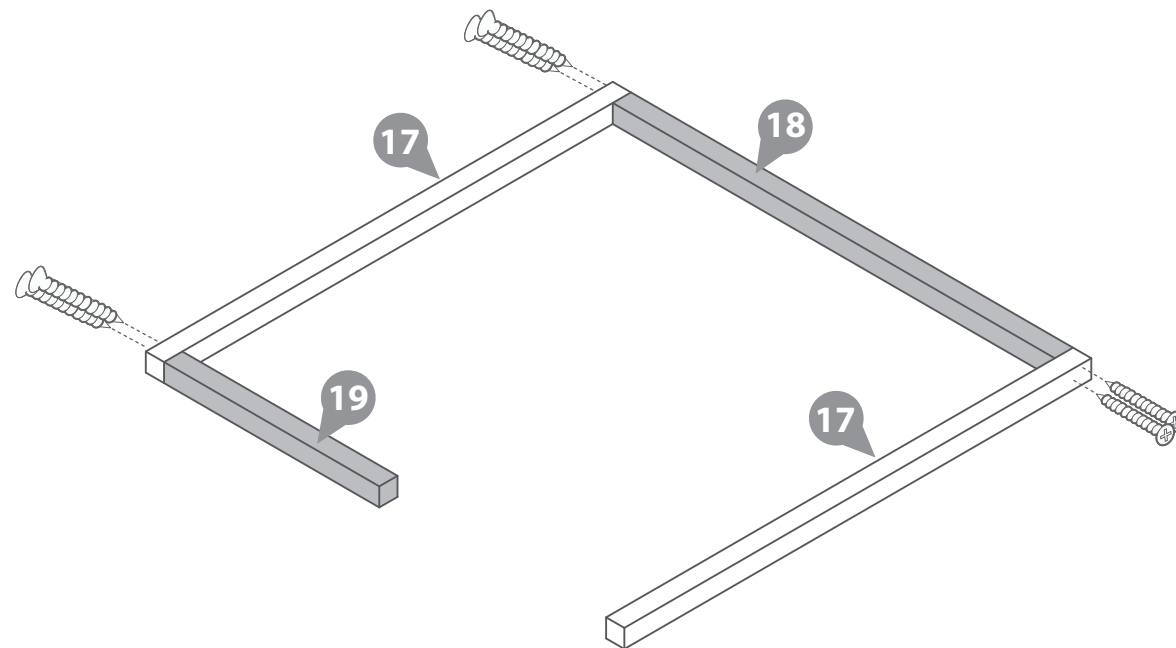

Step 3

Fix the Door Panel (No. 1) with 3x40mm screws.

3x40mm screws.

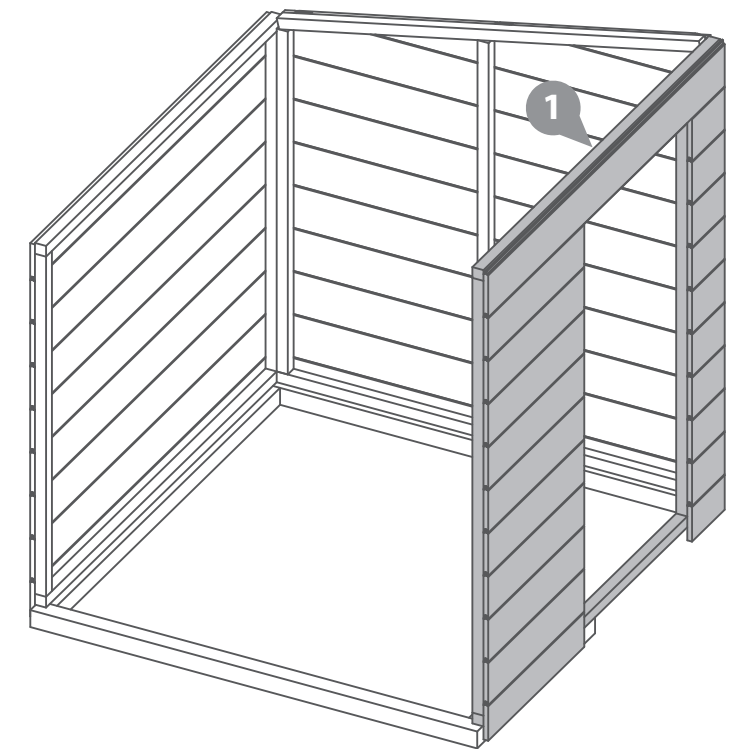
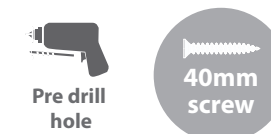

If you have purchased a 10x4 dog run with pack B extension then skip to step 12
If you have purchased a 12x4 dog run with 2 x pack B extension then skip to step 21

8x4 Run

Step 4

Place the remaining Base Framing (No. 17, No. 19 & No. 20) into position and secure to each with 2x70mm screws.

The Run base framing does not fix to the Kennel area

****Do NOT fix to the base framing until the Roof is secured****

4x70mm screws.

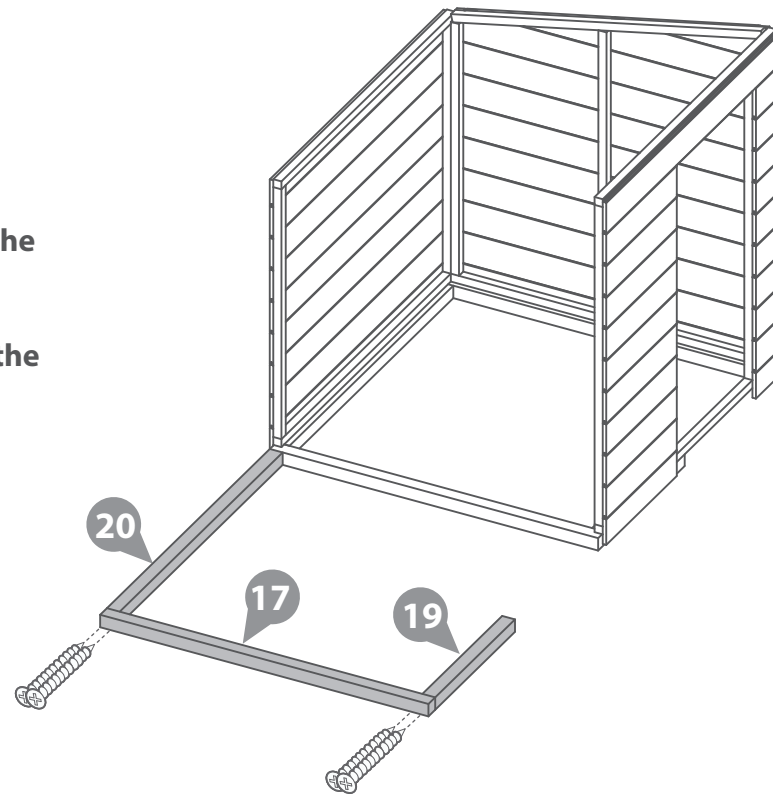

Step 6

Place the Central Gable (No. 7) into position and secure with 3x40mm screws per side.

The Central Gable fixes to the framing of the panels that make up the Run area.

****Do NOT fix to the base framing until the Roof is secured****

6x40mm screws.

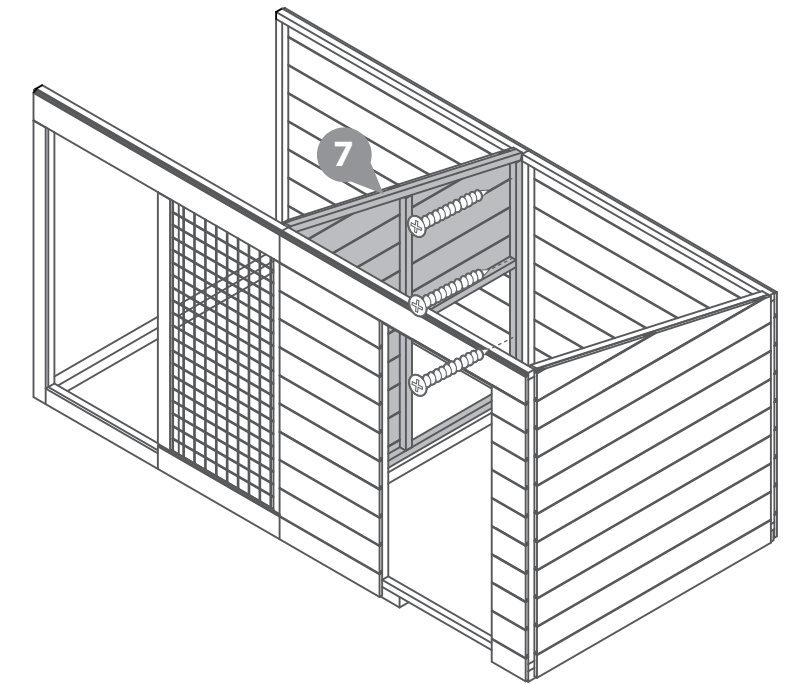
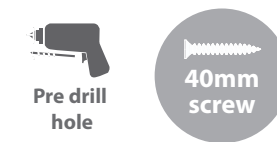

Step 5

Fix the remaining Back Panel (No. 8) and the Run Door Panel (No. 3) into position and secure with 3x40mm screws per panel.

****Do NOT fix to the base framing until the Roof is secured****

6x40mm screws.

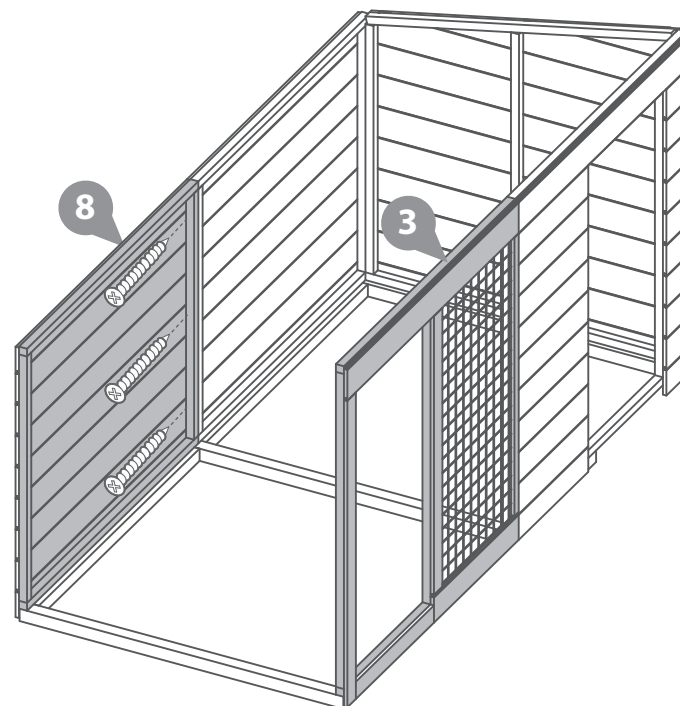

Step 7

Place the Left Gable (No. 6) into position and secure with 3x40mm screws per side.

****Do NOT fix to the base framing until the Roof is secured****

6x40mm screws.

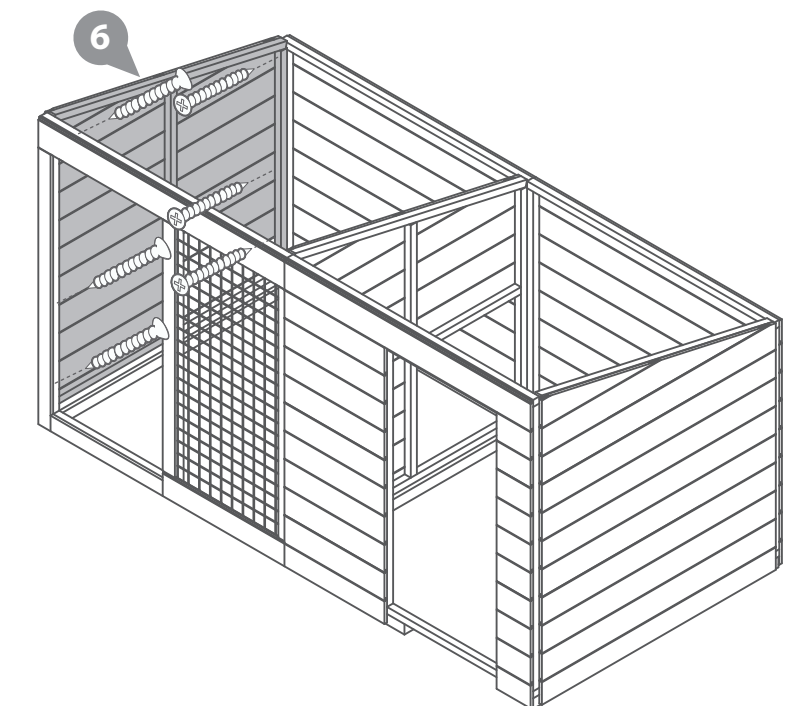
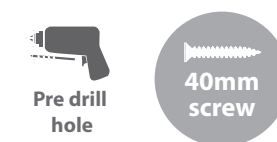

Step 8

Fix the Centre Framing (**No. 21**) to the Centre Gable with 3x40mm screws.

****Do NOT fix to the base framing until the Roof is secured****

3x40mm screws.

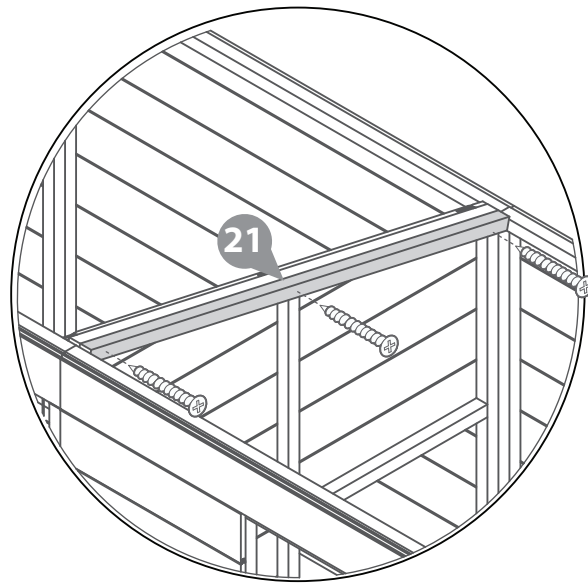

Step 10

Fix the assembled roof panels to the building with 12x30mm screws per roof sheet.

****Do NOT fix to the base framing until the Roof is secured****

24x30mm screws.

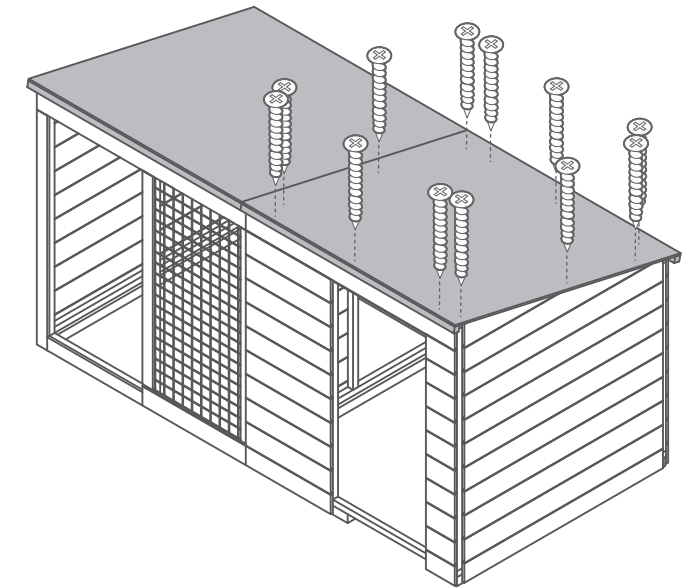

Step 9

Fix the Eaves Frames (**No. 16**) to the back and front of the Roof OSB (**No. 9**) with 3x30mm screws per Eaves frame.

****Do NOT fix to the base framing until the Roof is secured****

12x30mm screws.

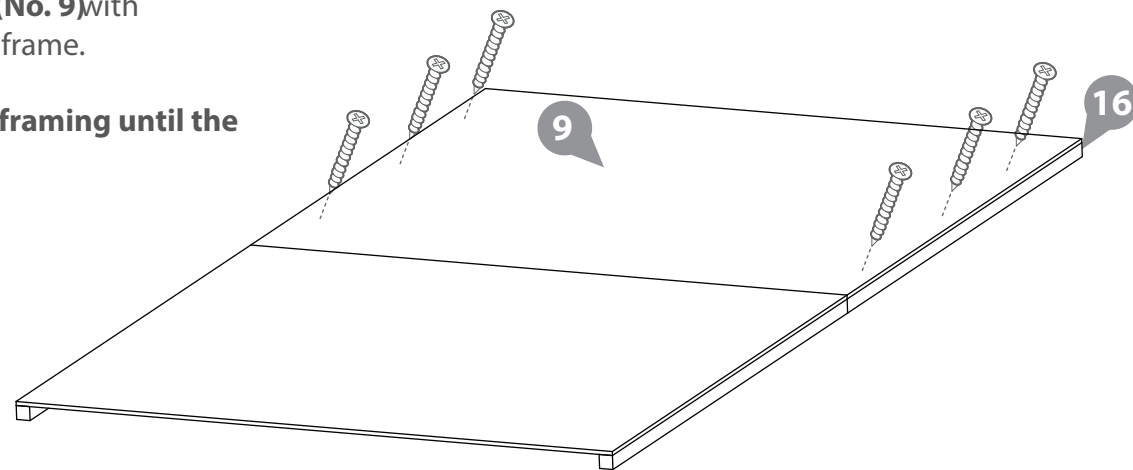

Step 11

Fix the building to the Base Framing with 50mm screws evenly spaced.

24x50mm screws.

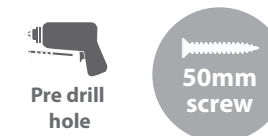

10x4 Run With Extension (Pack A + Pack B)

Step 12

Place the Base Framing (No. 17, 19, 20, 29, 30,) into position and secure to each with 2x70mm and 3x70mm screws.

****Do NOT fix to the base framing until the Roof is secured****

11x70mm screws.



70mm screw

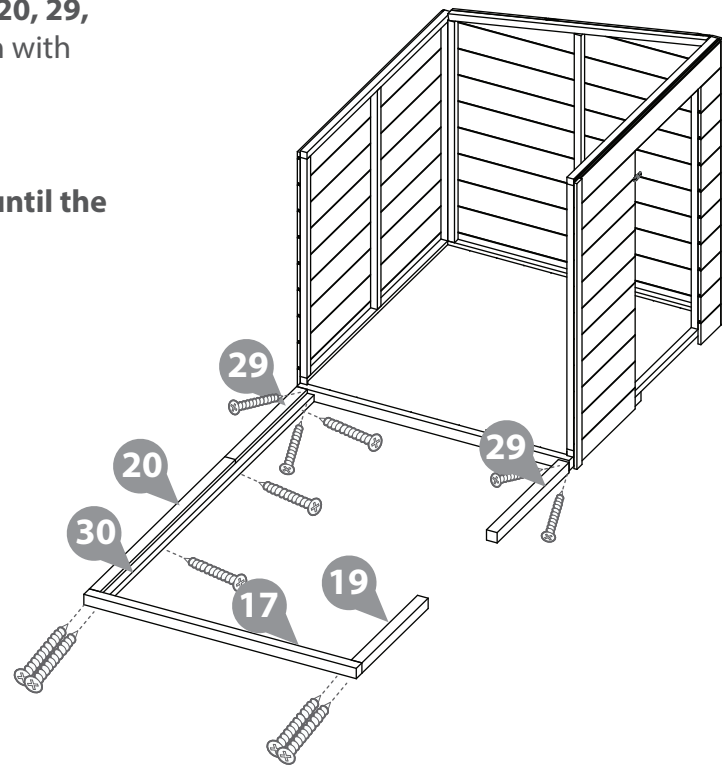

Step 13

Fix the Small Back Panel (No. 22) and the Mesh Panel (No. 23) into position and secure with 3x40mm screws per panel.

****Do NOT fix to the base framing until the Roof is secured****

6x40mm screws.



50mm screw

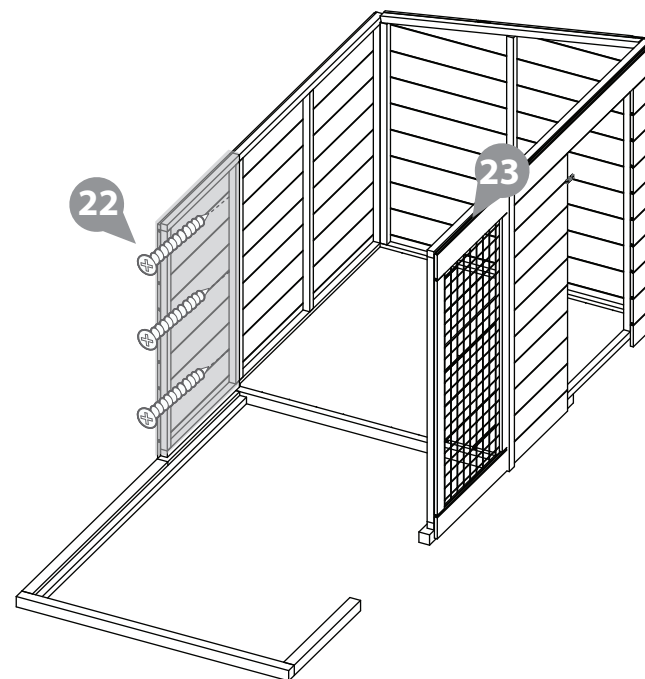

Step 14

Place the Central Gable (No. 7) into position and secure with 3x40mm screws per side.

The Central Gable fixes to the framing of the panels that make up the Run area.

****Do NOT fix to the base framing until the Roof is secured****

6x40mm screws.



40mm screw

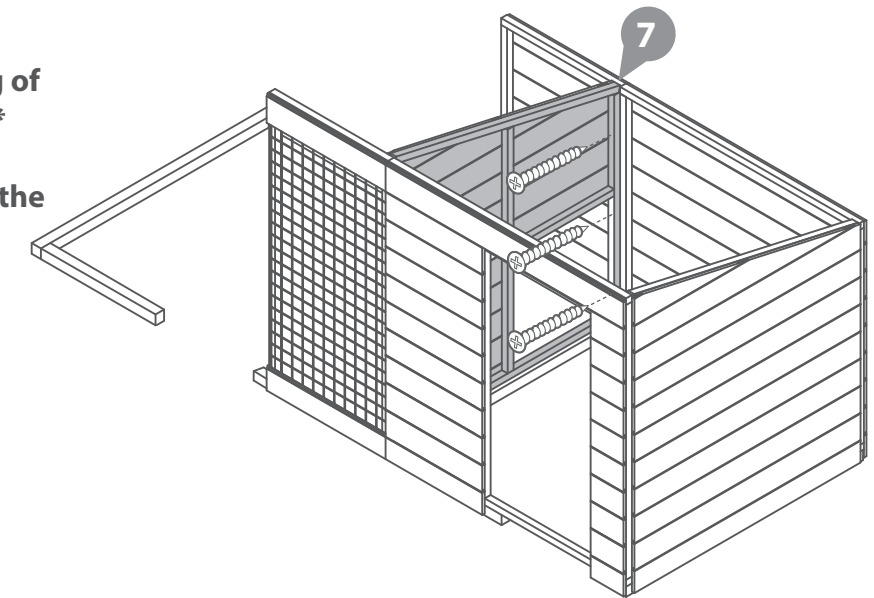

Step 15

Place the Run Door Panel (No. 3) the remaining Back Panel (No. 8) and the Left Gable (No. 6) into position and secure with 3x40mm screws per side.

****Do NOT fix to the base framing until the Roof is secured****

12x40mm screws.



40mm screw

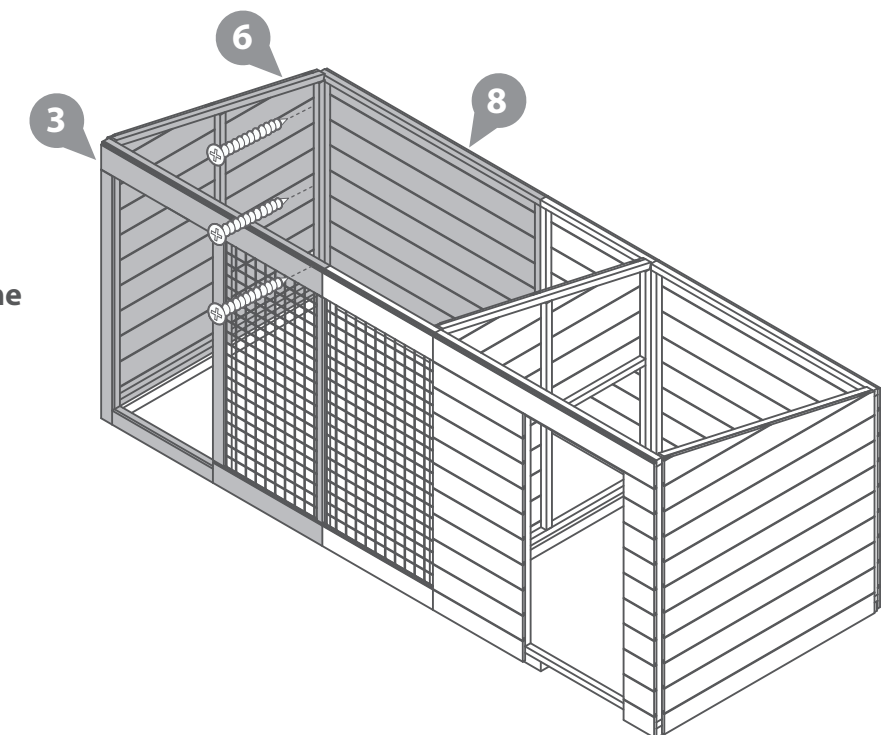

Step 16

Fix the Roof Blocks (No. 27) to the framing where the two panels meet with 2x40mm screws per Block.

Secure the Roof support (No. 26) to the blocks with 2x50mm screws.

Make sure the Roof support is inline with the gable tops

****Do NOT fix to the base framing until the Roof is secured****

2x50mm screws.
4x40mm screws.

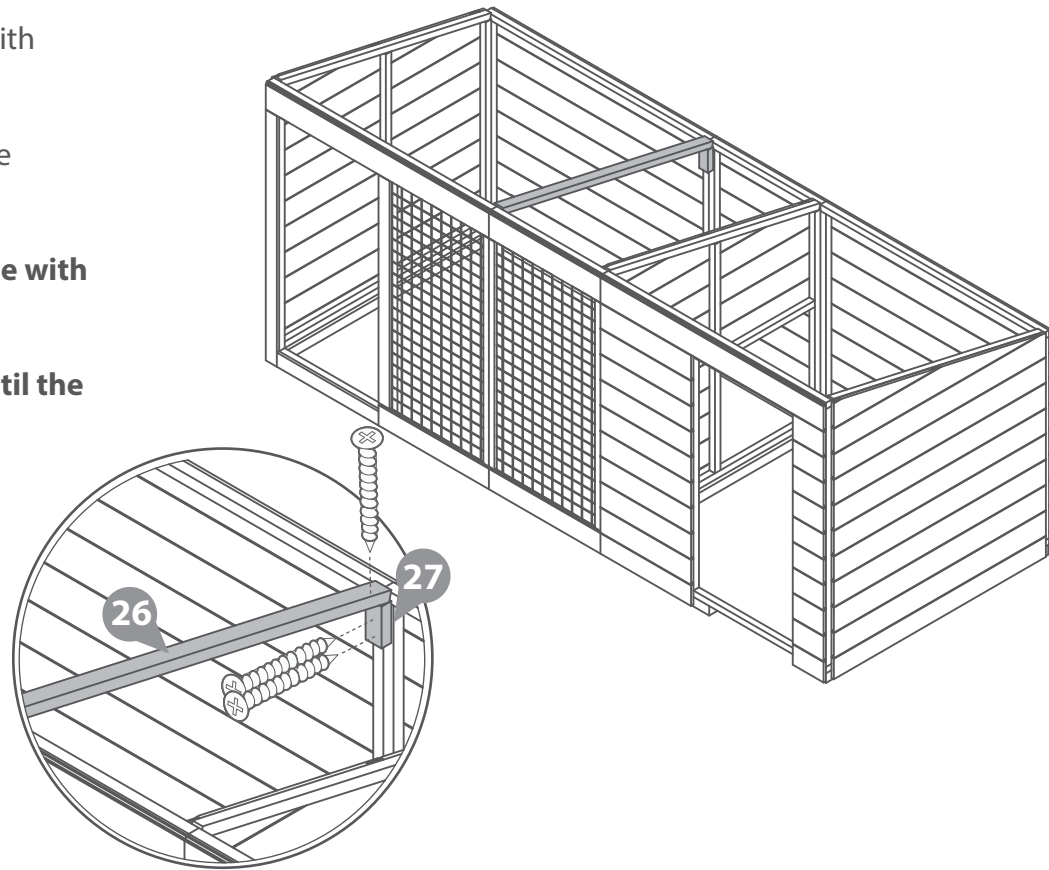

Step 17

Fix the Centre Framing (No. 21) to the Centre Gable with 3x40mm screws.

****Do NOT fix to the base framing until the Roof is secured****

3x40mm screws.

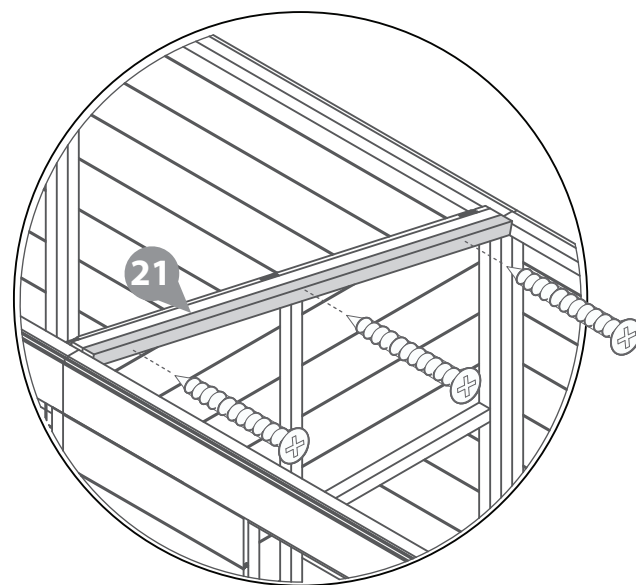

Step 18

Fix the Eaves Frames (No. 16 & 28) to the Roof OSB (No. 9 & 24) with 3x30mm screws per Eaves frame.

****Do NOT fix to the base framing until the Roof is secured****

4x30mm screws.

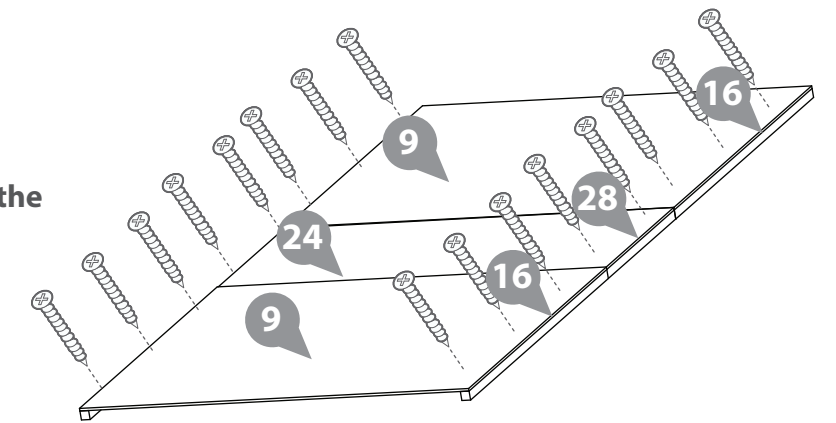

Step 19

Fix the assembled roof panels to the building with 12x30mm screws per roof sheet.

****Do NOT fix to the base framing until the Roof is secured****

36x30mm screws.

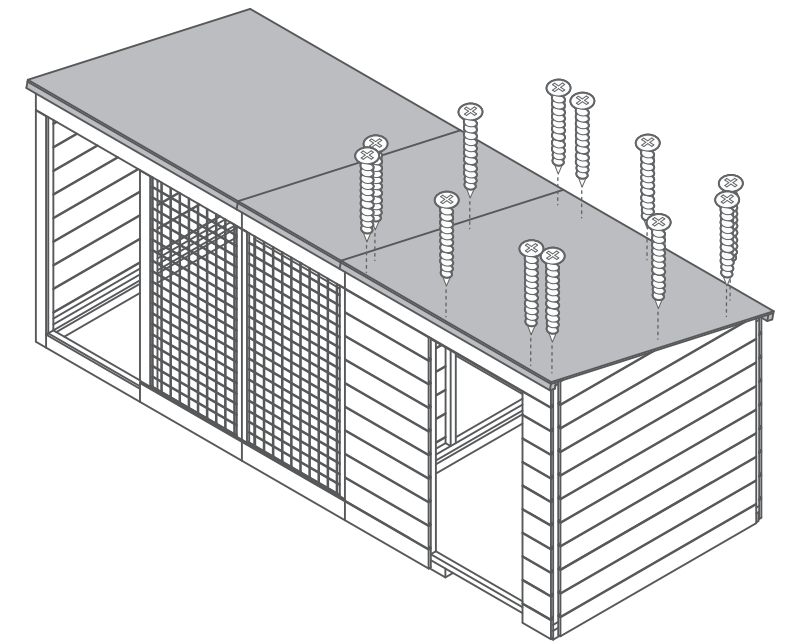

Step 20

Fix the building to the Base Framing with 50mm screws evenly spaced.

24x50mm screws.



12x4 Run With Extension (Pack A + Pack B x2)

Step 21

Place the Base Framing (No. 17, 19, 20, 29, 30) into position and secure to each with 2x70mm and 3x70mm screws.

****Do NOT fix to the base framing until the Roof is secured****

4x70mm screws.

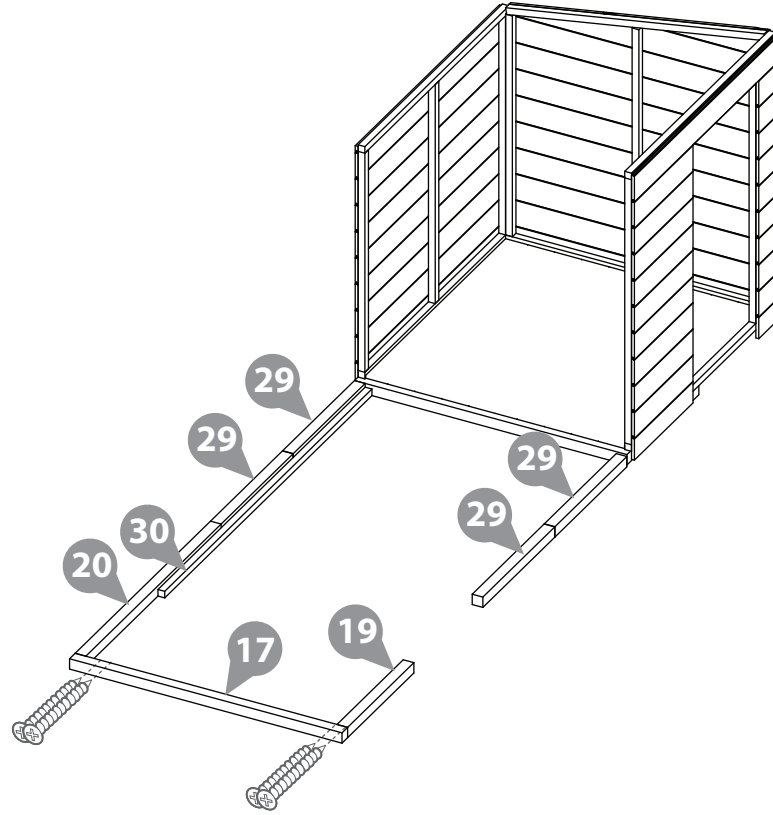

Step 23

Place the Central Gable (No. 7) into position and secure with 3x40mm screws per side.

The Central Gable fixes to the framing of the panels that make up the Run area.

****Do NOT fix to the base framing until the Roof is secured****

6x40mm screws.

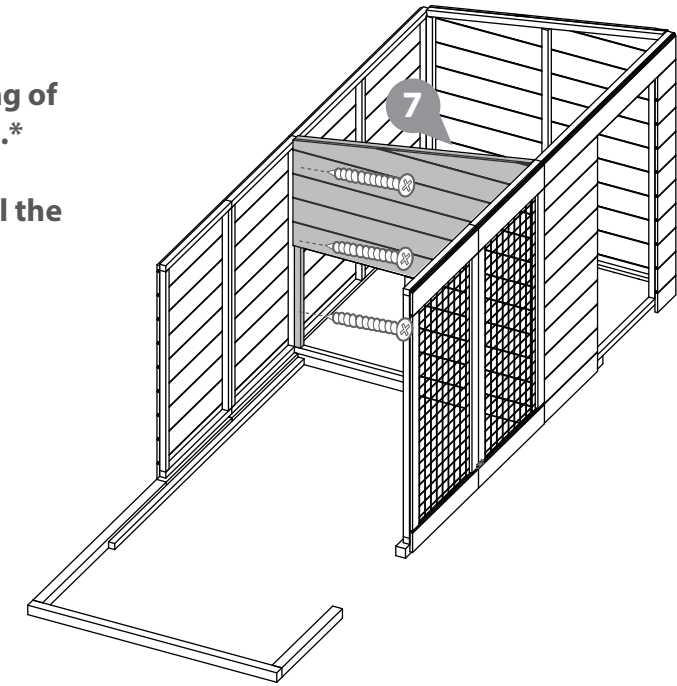
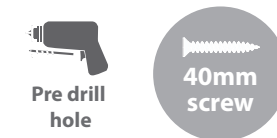

Step 22

Fix a Back Panels (No. 22) and the Mesh Panels (No. 23) into position and secure with 3x40mm screws per panel.

****Do NOT fix to the base framing until the Roof is secured****

12x40mm screws.

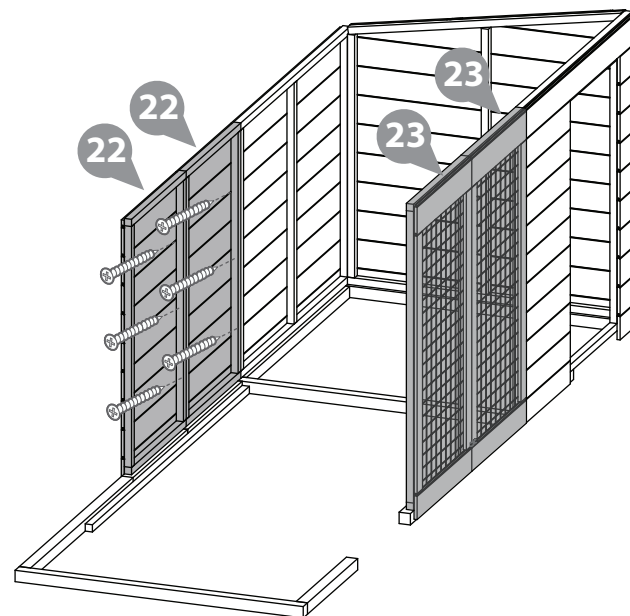

Step 24

Place the Run Door Panel (No. 3) the remaining Back Panel (No. 8) and the Left Gable (No. 6) into position and secure with 3x40mm screws per side.

****Do NOT fix to the base framing until the Roof is secured****

15x40mm screws.

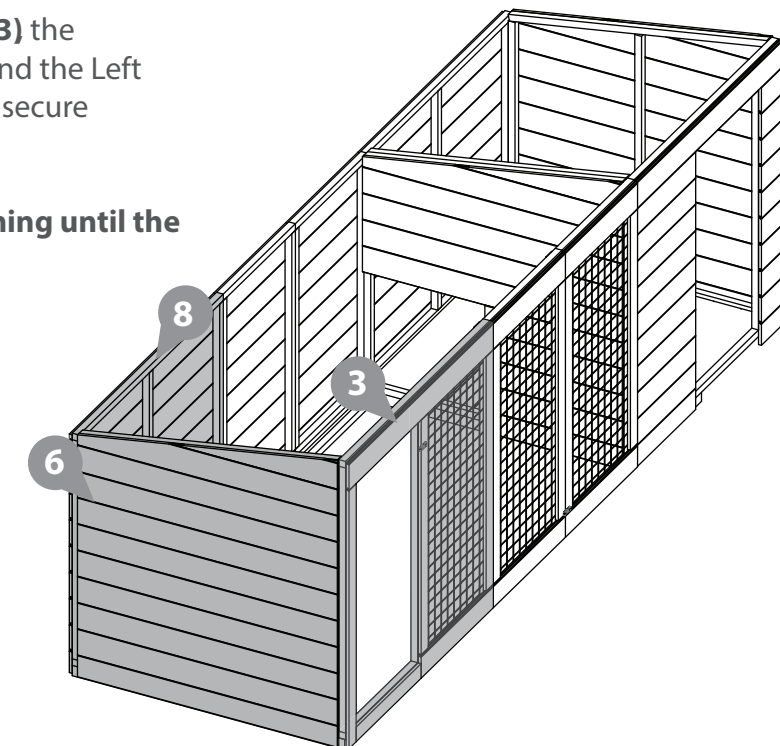

Step 25

Fix the Roof Blocks (No. 27) to the framing where the two panels meet with 2x40mm screws per Block.

Secure the Roof support (No. 26) to the blocks with 2x50mm screws.

Make sure the Roof support is inline with the gable tops

****Do NOT fix to the base framing until the Roof is secured****

2x50mm screws.
4x40mm screws.

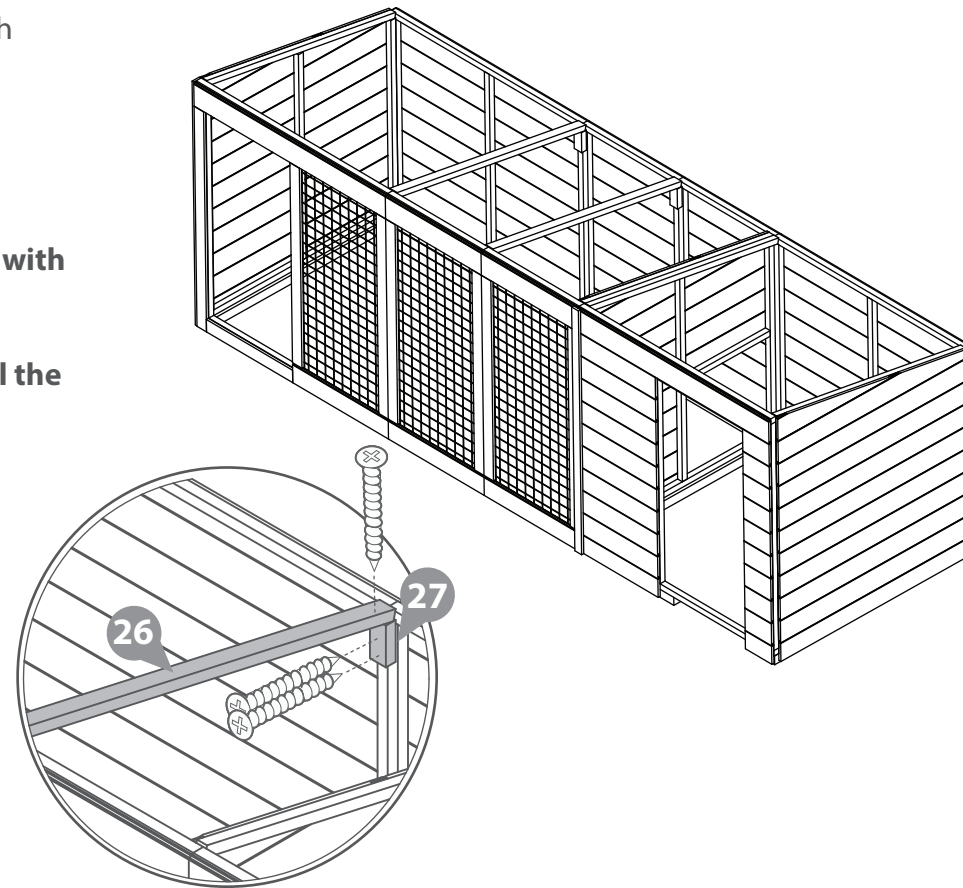

Step 26

Fix the Centre Framing (No. 21) to the Centre Gable with 3x40mm screws.

****Do NOT fix to the base framing until the Roof is secured****

3x40mm screws.

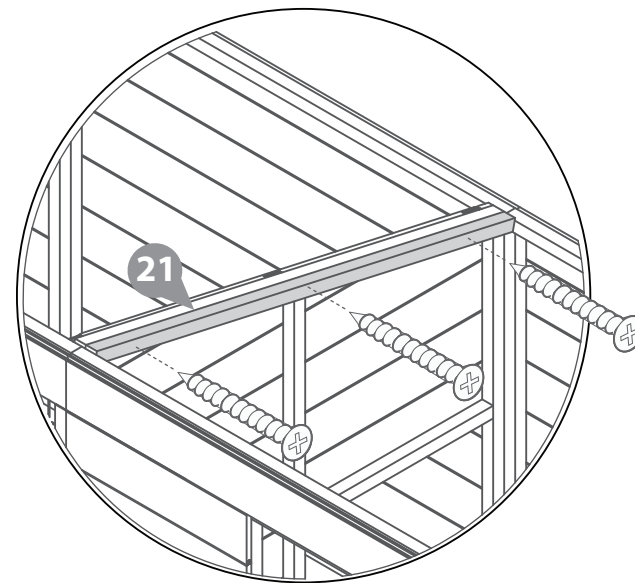

Step 27

Fix the Eaves Frames (No. 16, 28) to the Roof OSB (No. 9, 24) on both sides with 3x30mm screws per Eaves frame. Secure through the OSB sheet.

****Do NOT fix to the base framing until the Roof is secured****

18x30mm screws.

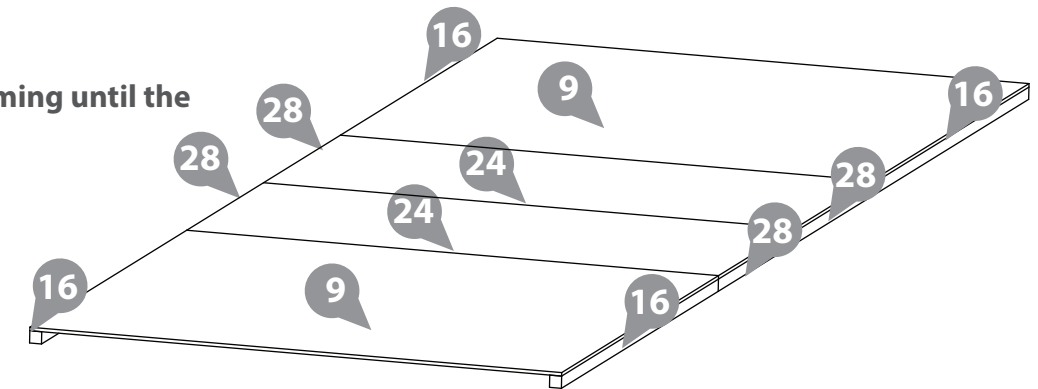

Step 28

Fix the assembled roof panels to the building with 12x30mm screws per roof sheet.

****Do NOT fix to the base framing until the Roof is secured****

36x30mm screws.

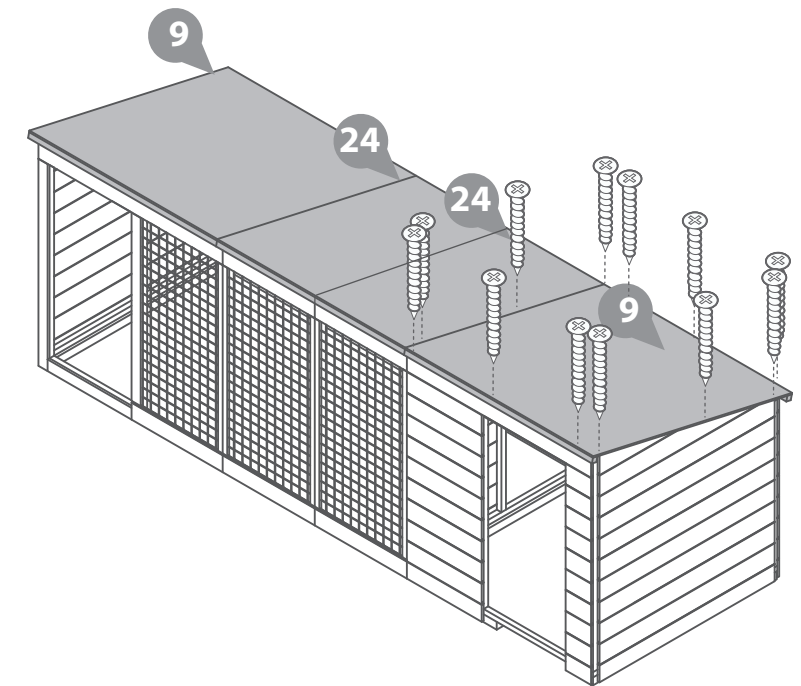

Step 29

Fix the building to the Base Framing with 50mm screws evenly spaced.

24x50mm screws.



****The following steps are applicable to all buildings.****

Step 30

Cut the roof felt provided into equal lengths making sure that there is 50mm of overhang on both sides.

Place the first strip on the back of the building and lay the second overlaying the first sheet at the front.

Secure the felt in place with Felt tacks evenly spaced at 100mm intervals.

- 8x4 65x Felt tacks
- 10x4 85x Felt tacks
- 12x4 105x Felt tacks

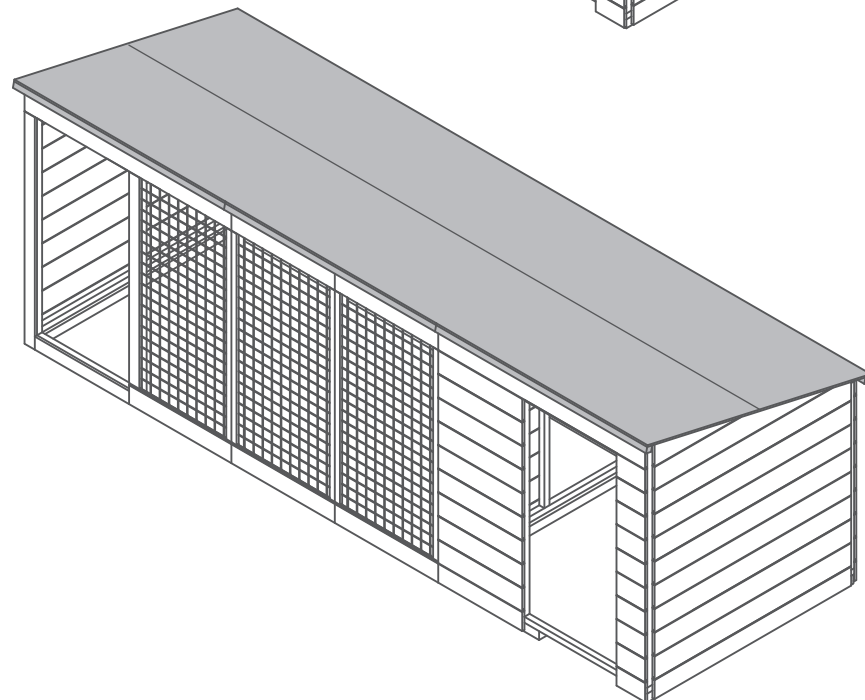
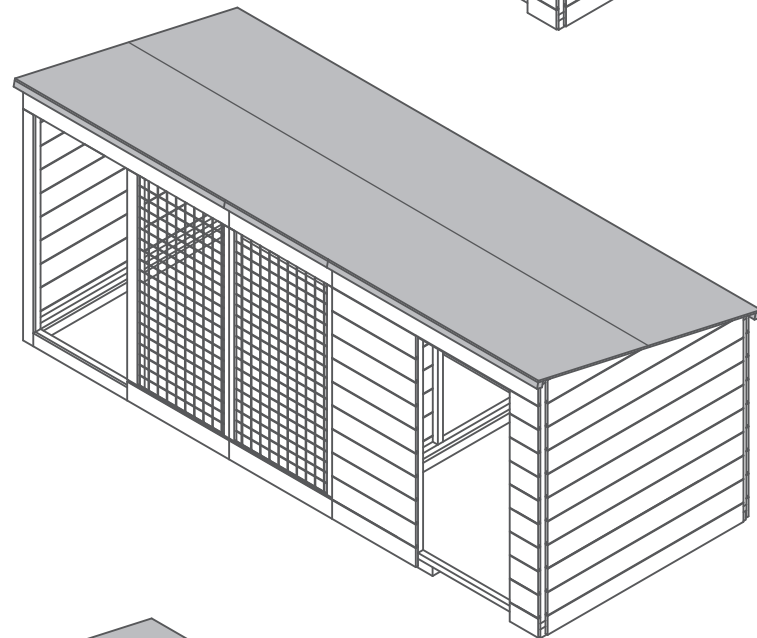
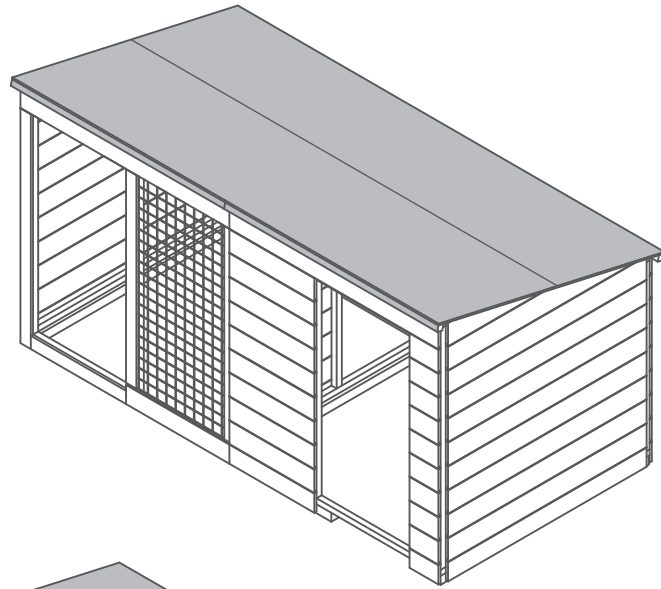
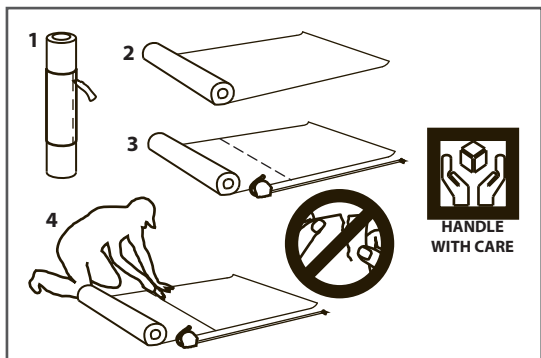
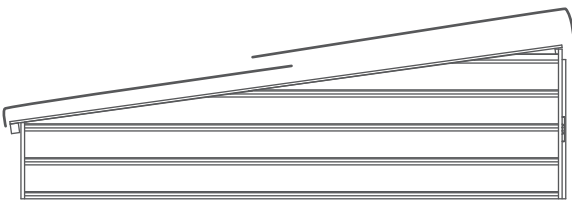

Step 31

Fix the Fascias (No. 14) to the building with 3x30mm screws per Fascia.

Some Fascias will need to be cut down to fit.

****8x4 building shown****

- 8x4, 10x4 -12x30mm screws.
- 12x4 -15x30mmscrews

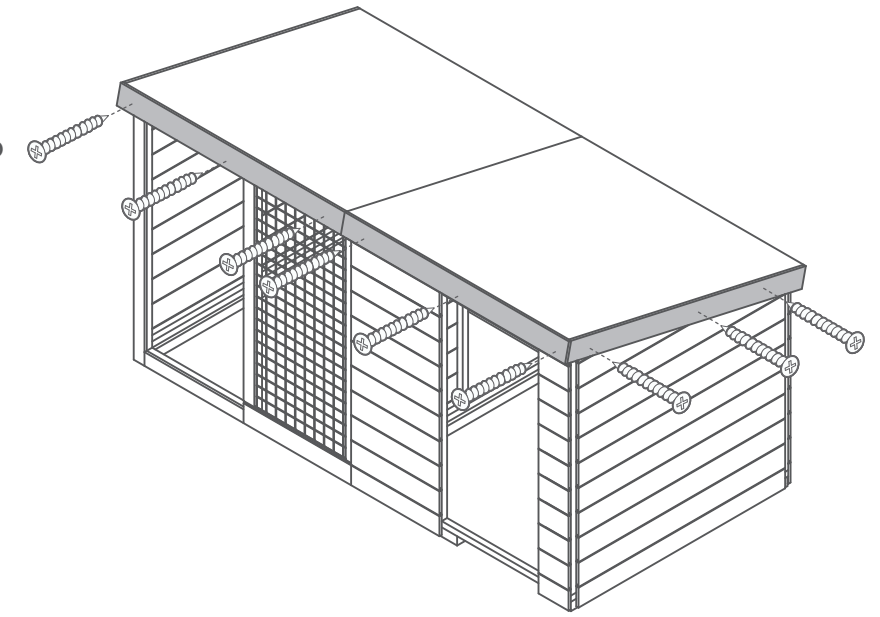

Step 32

Fix the Cover trims (No. 15) to the building with 3x30mm screws per Trim.

The rear Cover trims will need to be cut down to fit.

A Cover trim is provided for each corner and for each point that a panel meets another.

****8x4 building shown****

- 8x4 -18x30mm screws.
- 10x4 -24x30mm screws.
- 12x4 -27x30mmscrews

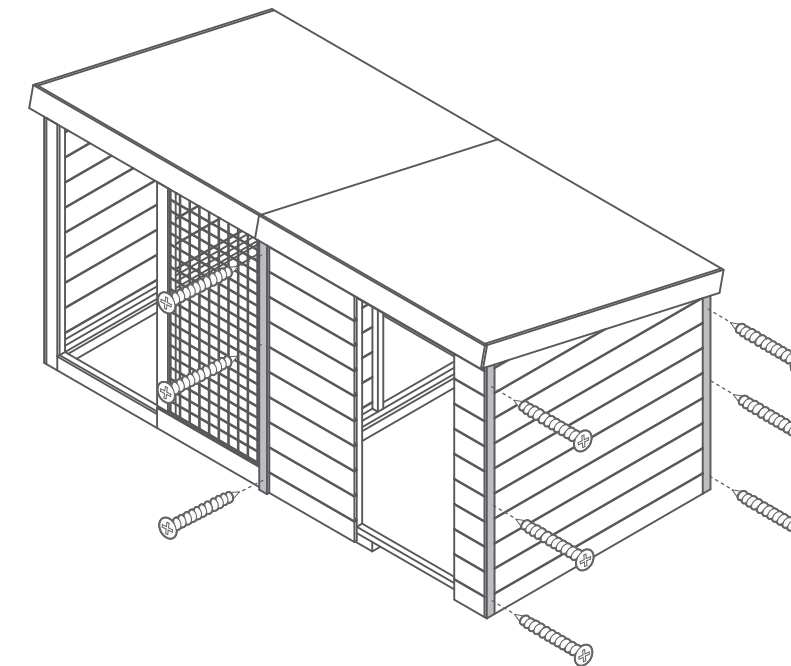

Step 33

To fix the kennel Door to the building, attach the hinges to the Door (**No. 2**) with 4x20mm screws per hinge.

Position the Door into the door opening and fix into position with 3x30mm screws per hinge.

****8x4 building shown****

12x20mm screws
9x30mm screws

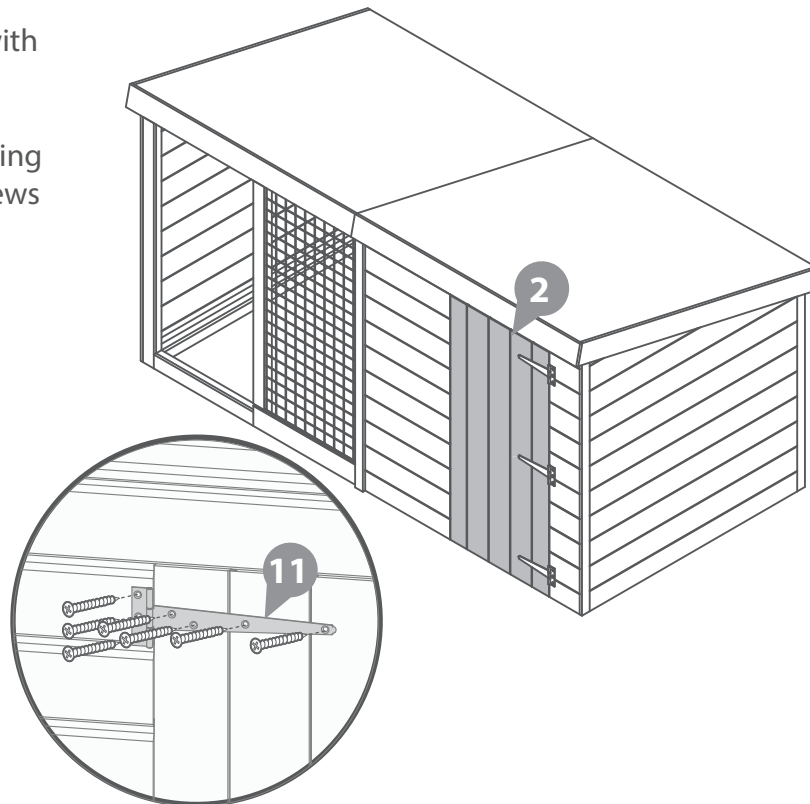
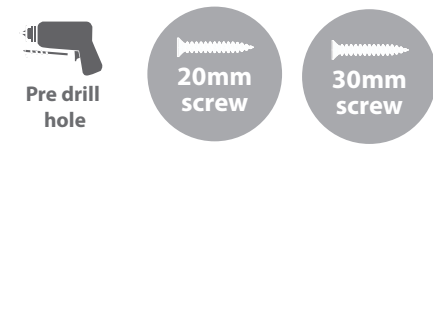

Step 34

To fix the Run Door to the building, attach the hinges to the Mesh Door (**No. 4**) with 4x20mm screws per hinge.

Position the Door into the door opening and fix into position with 3x30mm screws per hinge.

****8x4 building shown****

12x20mm screws
9x30mm screws

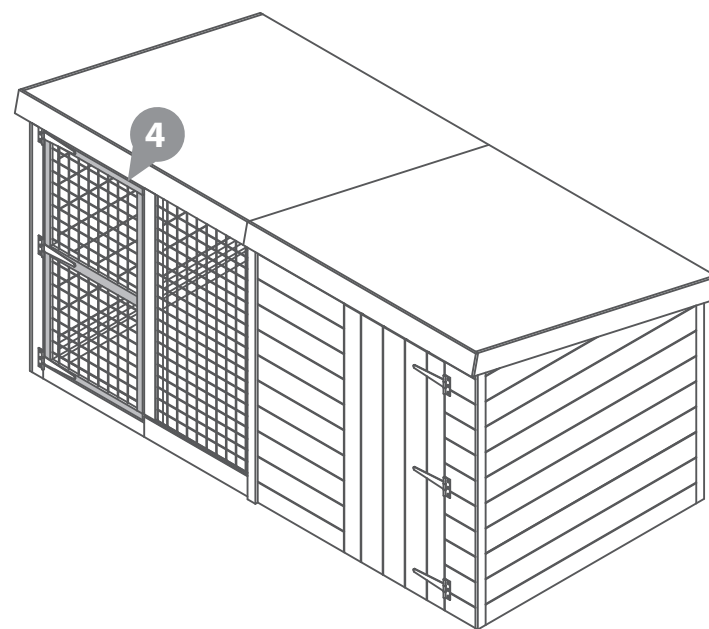

Step 35

Fix a Pad Bolt (**No. 13**) to each door. Make sure to screw through the Door framing.

Use 8x20mm screws to attach to the Door/Mesh Door and 4x30mm screws to attach the Pad Bolt catch to the building.

Attach a Turn button (**No. 12**) to the top and bottom of each door. 1x20mm screw per Turn Button.

****8x4 building shown****

20x20mm screws
8x30mm screws

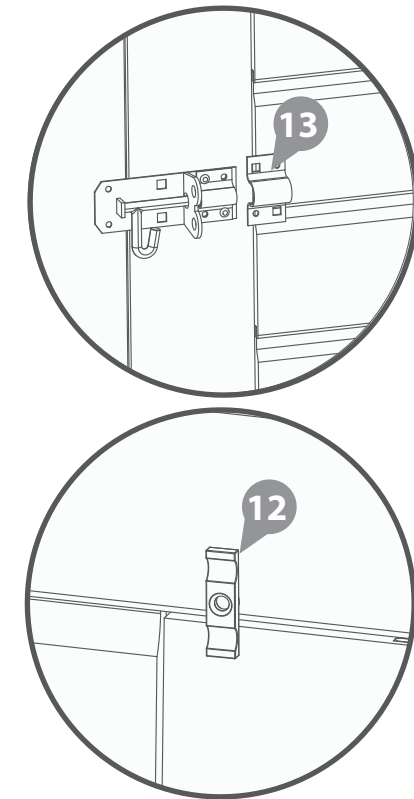

Step 36

Place the Floor tiles (**No.10**) into the kennel area as shown.

These panels are removable so do not need securing in position.

***For ease of use, Drill a finger sized hole in one tile.**

****8x4 building shown****

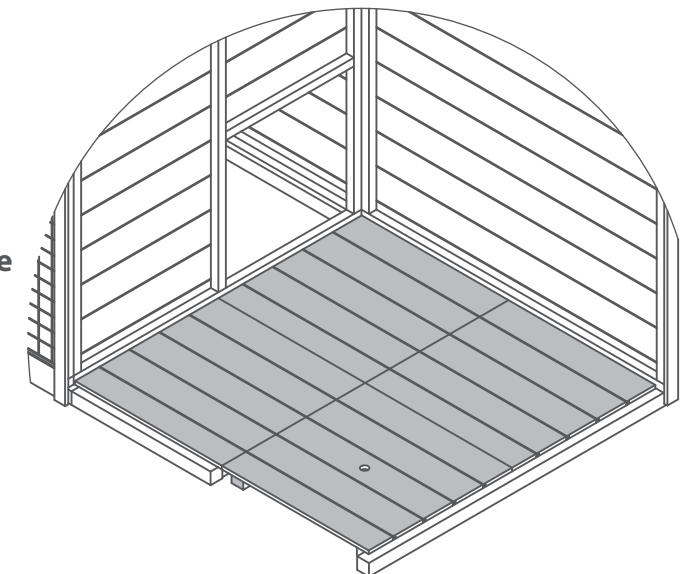

All our garden buildings have been designed and manufactured with care and attention to be the perfect addition to your outdoor space. To ensure you do get the best out of your new garden building and to increase the longevity we advise that you follow the product instructions and our manufacturer's recommendations as detailed below. Thank you for choosing a Mercia Garden product!

1 Choosing the most suitable location for your garden building...

A minimum of 60cm should be left around the perimeter of your garden building to allow access for maintenance, annual treatment and to allow air flow around the building.

Where possible you should avoid placing your garden building underneath large trees to prevent the tree causing damage to the building.

2 Preparing the base for your garden building...

All our buildings must be built on a firm, level base to ensure the longevity of the building and prevent the wood from distorting. We recommend either concrete, concrete slabs or a wooden base, such as our 'Portabase'.

The base should be slightly smaller than the external measurement of the building, i.e. the cladding should overlap the base, creating a run off for water and preventing water from pooling underneath the building.

We also recommend that the floor of the garden building is a minimum of 25mm above the surrounding ground level to avoid flooding.

3 After installation...

Once your garden building has been installed it will need to be treated as soon as possible and annually to prevent the timber from deteriorating and to waterproof it. This is required to maintain the anti-rot guarantee.

Dip Treated buildings - Require a preservative treatment to protect against rot and decay and a waterproof treatment to prevent water ingress

Pressure Treated buildings - Require a waterproof treatment to prevent water ingress

Log Cabins/Insulated Garden Rooms - Are supplied untreated and require a preservative and waterproofing treatment

We also recommend using a silicon sealant on the inside and outside of the windows as soon as possible after assembly and treatment to fully seal the windows.

Roofing felt/covering should be checked annually and replaced or fixed accordingly.

4 General maintenance and wood characteristics

As wood is a natural material it may be affected by the following:

Shrinkage and warping - The timber used in the construction of your garden building will have retained some of its natural moisture content. The moisture content of the timber will vary, depending upon prevailing environmental conditions, which will result in the components either naturally expanding or contracting. As the components dry out shrinkage may occur. A good waterproofing treatment from the start is the best protection to minimise the effect of moisture loss/intake.

In extended periods of very warm weather getting some moisture to the building will help the overall balance. You can do this by spraying it down lightly with a garden hose. In contrast after snow fall try to remove the snow as best as possible from the roof to prevent moisture intake and to remove the extra weight.

Top tip - using a garden brush will help you to reach the highest part of the building to remove snow and any debris left from bad weather.

Damp and mould - During the winter months, cold and damp conditions can result in an increased amount of moisture within your garden building, especially when used infrequently. Condensation can form on the timber and other items stored within your garden building. If left this moisture is likely to cause mould and mildew. To prevent the build-up of moisture, we recommend leaving the door or windows of your building open from time to time, to allow the fresh air to circulate. We also advise against storing wet or damp items in your garden building as this will also increase the level of moisture in the building. If mould or mildew does start to form within your building we recommend using an anti-mould cleaner to remove it and to prevent it spreading, which if left untreated could permanently damage your garden building.

Splits, cracks and knots - You may notice small splits and cracks in some components or holes may appear where knots shrink and fall out. This will not affect the structure of your Garden building however if you wish to fill them this can be easily done using any good quality wood filler.

Sap - is naturally occurring in wood and may appear in some boards of your garden building. If you wish to remove the sap, we advise waiting until it is dry and then using a sharp knife to carefully remove it. If the removal of the sap causes a hole in the timber, we recommend using a good quality wood filler to fill it.

For more handy hints and tips on how to care and maintain your garden building please refer to the MGP Customer Portal at www.mgplogistics.co.uk

Any further questions?

Contact our
Customer Service
Team on:
01636 821215

1 Manufacturer's Warranty

All Mercia Garden Products are supplied with a 1 year warranty on all parts against manufacturing defects.
This warranty does not cover movement, warping or splitting of timber products over time.

This warranty will be voided if any of the following occur:

1. The building has been customised or modified/adapted in any way.
2. The person claiming is not the original purchaser of the building.
3. Any damage has been caused by or as a result of misuse.
4. The building has not been maintained and cared for in accordance to our advisories and manufacturer's recommendations.
5. The building has not been treated annually or as per the manufacturer's recommendations, please ensure receipts are kept to validate this claim.
6. The building has not been erected, fitted or installed as per the supplier instructions.
7. The building has not been erected on a suitable sized firm flat, solid level concrete/slab base or placed on pressure treated bearers.
8. The building is or has been placed with 2 feet (60cm) of any obstructions (walls, trees, plants, fences etc.) which can allow moisture to penetrate the timber.
9. The roofing felt has been incorrectly fitted or damaged allowing water ingress, or not properly maintained.
10. Any windows and joints have not been sealed, inside and out, with silicone or other watertight sealant.
11. Any timber has been cut, pierced or drilled without subsequent application of approved cut-end treatment.

2 Anti-rot Guarantee

Mercia Garden Products offer a 10 year anti-rot guarantee on all dip treated (a preparatory treatment) and 15 years on all pressure treated products. This guarantee covers solid timber against rot, decay, blue stain and insect attack.

To validate the guarantee the building must be treated with a recognised wood preserver/water proof top coat (as detailed within manufacturer's recommendations) as soon as possible after assembly and annually thereafter.

This guarantee does not cover movement, warping or splitting of timber products over time.

This guarantee will be voided if any of the following occur:

1. The building has been customised or modified/adapted in any way.
2. The person claiming is not the original purchaser of the building.
3. Any damage is caused by or as a result of misuse.
4. The building has not been maintained and cared for in accordance to our advisories and manufacturer's recommendations.
5. The building has not been treated annually or as per the manufacturer's recommendations, please ensure receipts are kept to validate this claim.
6. The building has not been erected, fitted or installed as per the supplier instructions.
7. The building has not been erected on a suitable sized firm flat, solid level concrete/slab base or placed on pressure treated bearers.
8. The building is or has been placed with 2 feet (60cm) of any obstructions (walls, trees, plants, fences etc.) which can allow moisture to penetrate the timber.
9. The roofing felt has been incorrectly fitted or damaged allowing water ingress, or not properly maintained.
10. Any windows and joints have not been sealed, inside and out, with silicone or other watertight sealant.
11. Any timber has been cut, pierced or drilled without subsequent application of approved cut-end treatment.



REGISTER FOR YOUR
ANTI-ROT
GUARANTEE TODAY

PLEASE SCAN HERE:

