

General Instructions

Please retain product label and instructions for future reference

0644RANE0403HGDD2SW-V1

44MM LOG CABIN, REVERSE APEX, NO EXTRAS, 4X3M, HALF GLAZED DOUBLE DOORS, TWO SHORT WINDOWS.

BEFORE YOU START PLEASE READ INSTRUCTIONS CAREFULLY

- Check the pack and make sure you have all the parts listed.
- When you are ready to start, make sure you have the right tools at hand (not supplied) including a Phillips screwdriver, Stanley knife, wood saw, step ladder and drill with 2mm bit.
- Ensure there is plenty of space and a clean dry area for assembly.

TIMBER

As with all natural materials, timber can be affected during various weather conditions. For the duration of heavy or extended periods of rain, swelling of the wood panels may occur. Warping of the wood may also occur during excessive dry spells due to an interior moisture loss. Unfortunately, these processes cannot be avoided but can be helped. It is suggested that the outdoor building is sprayed with water during extended periods of warm sunshine and sheltered as much as possible during rain or snow.

BUILDING A BASE

When thinking about where the building and base are going to be constructed: Ensure that there will be access (60cm) to all sides for maintenance work and annual treatment.

Ensure the base is level and is built on firm ground, to prevent distortion. Refer to diagrams for the base dimensions, The base should be slightly smaller than the external measurement of the building, i.e. The cladding should overlap the base, creating a run off for water. It is also recommended that the floor be at least 25mm above the surrounding ground level to avoid flooding.

TYPES OF BASE

- Concrete 75mm laid on top of 75mm hard-core.
- Slabs laid on 50mm of sharp sand.

Whilst all products manufactured are made to the highest standards of Safety and in the case of childrens products independently tested to EN71 level, we cannot accept responsibility for your safety whilst erecting or using this product.

Refer to the instructions pages for your specific product code



All buildings should be erected by two adults



Winter = High Moisture = Expansion
Summer = Low Moisture = Contraction



2mm Drill bit

For ease of assembly, you **MUST** pilot drill all screw holes and ensure all screw heads are countersunk.



CAUTION

Every effort has been made during the manufacturing process to eliminate the prospect of splinters on rough surfaces of the timber. You are strongly advised to wear gloves when working with or handling rough sawn timber.



For ease of assembly use a rubber mallet to fit the log boards. Do **NOT** use a heavy hammer.



Ensure to measure and check before cutting boards.



It is advisable to use a hand saw when cutting roof and floor boards.



To ensure log boards are even, use a spirit level to check each layer has been installed correctly.

Screws & Nails



Bolts



To identify the fixings required for each step use a measuring tape.

For assistance please contact customer care on: 01636 821215

Mercia Garden Products Limited,
Sutton On Trent,
Newark,
Nottinghamshire,
NG23 6QN

www.merciagardenproducts.co.uk



Overall Dimensions:

Width = 4040mm
Depth = 3144mm
Height = 2601mm

Base Dimensions:

Width = 3818mm
Depth = 2814mm

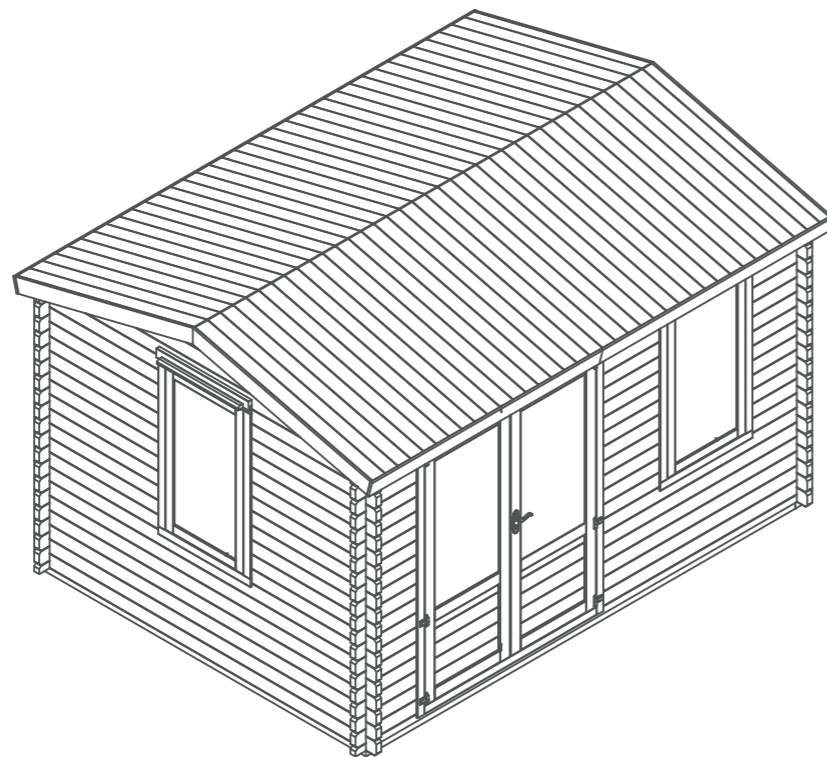

Before assembly
please make sure you have a
suitable base ready to erect your
building



MADE IN GREAT BRITAIN

Window Contents:

1

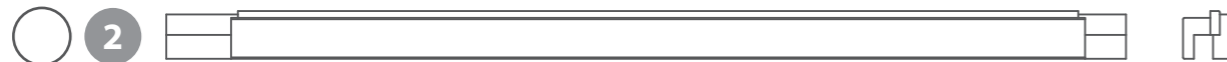
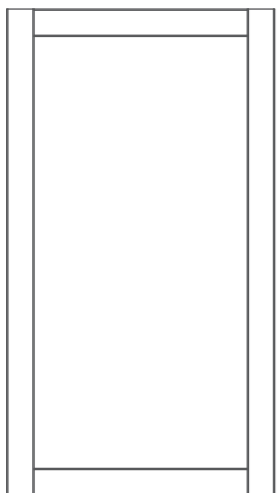

Window Frame Left Upright - 71x70x1412mm QTY 2
AI-0644OGWUFL-V3



Window Frame Right Upright - 71x70x1412mm QTY 2
AI-0644LOGWUFR-V3



Window Frame Top - 84x125x805mm QTY 2
AI-0644LOGWTF-V3



Window Frame Bottom - 71x70x805mm QTY 2
AI-0644LOGWBF-V3

6

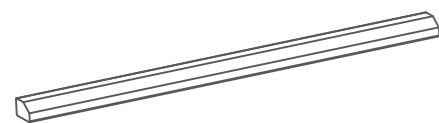

Rain Guard QTY 2
RG2844-710 (28x44x710mm)

7

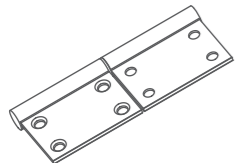

Flag Hinge QTY 4
PI-07-0211

8

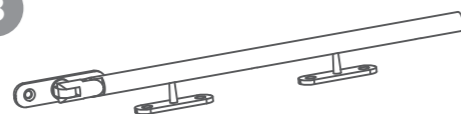

Casement Stay QTY 2
PI-07-0187

Double Door Contents:

9

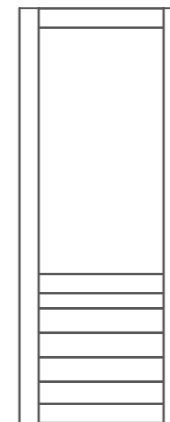

Master Door QTY 1
(Morticed for lock)
AI-06LOGDGM750X1900-V3

10



Secondary Door QTY 1
AI-06LOGDGS750X1900-V3

11



Door Frame Left Upright - 71x70x2065mm QTY 1
AI-0644LOGDUFL-V3

12



Door Frame Right Upright - 71x70x2065mm QTY 1
AI-0644LOGDUFR-V3

13



Door Frame Top - 84x125x1632mm QTY 1
AI-0644LOGDDTF-V3

14



Door Frame Bottom - 71x70x1508mm QTY 1
AI-0644LOGDDBF-V3

15



Door Strip - 16x60x1880mm QTY 1
S1660-1880mm

16

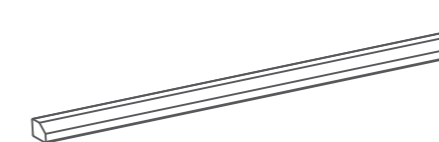

Rain Guard QTY 1
RG2844-1520 (28x44x1520mm)

17

Adjustable Hinge QTY 6 PI-07-0209

17a

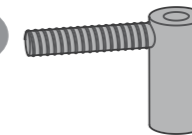

17b

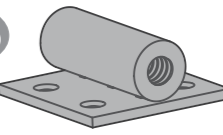

17c

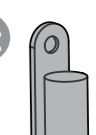

18

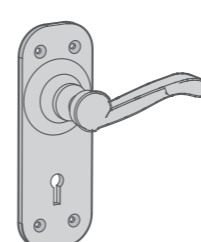

Handles (Pair) QTY 1
PI-07-0188

19

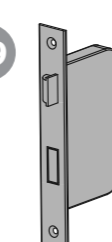

Mortice Lock QTY 1
PI-07-0017

20

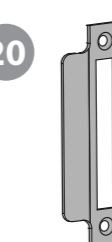

Key Plate QTY 1
PI-07-0017

21

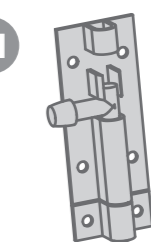

Tower Bolt QTY 2
PI-07-0114

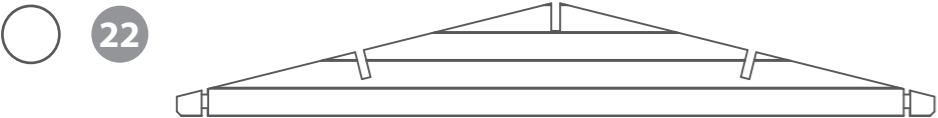

Gable - 2996mm QTY 1
AI-0644RANE0403HGDD2SW-G-V1

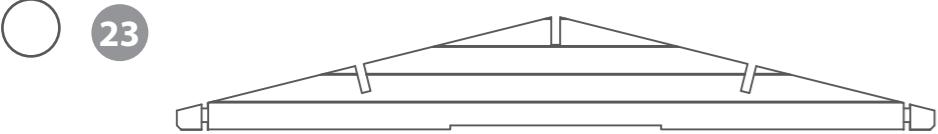

Gable Window Notch - 2996mm QTY 1
AI-0644RANE0403HGDD2SW-GW-V1



Starter Board - 44x66x4000mm QTY 2
LB44RT66-A-4000



Log Board - 44x120x2996mm QTY 26
LB44-A-2996



Log Board - 44x120x562mm QTY 30
LB44-B-562



Log Board - 44x120x1870mm QTY 6
LB44-B-1870



Log Board - 44x120x562mm QTY 12
LB44-C-562



Log Board - 44x120x1125mm QTY 24
LB44-B-1125



Log Board - 44x120x4000mm QTY 19
LB44-A-4000

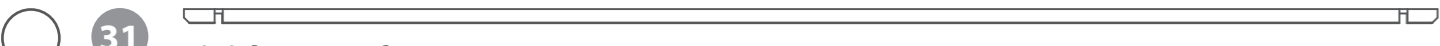

Finisher Board - 44x45x4000mm QTY 2
LB44RG45-A-4000



Log Board - 44x120x4000mm QTY 1
LB44-AD-4000



Roof Board - 16x121x1600mm QTY 74
MB16-1600



Floor Board - 16x121x2725mm QTY 35
MB16-C-2725

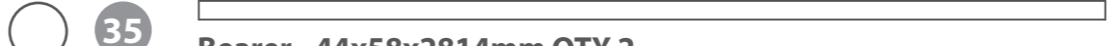

Bearer - 44x58x2814mm QTY 2
F4444-2814-PT

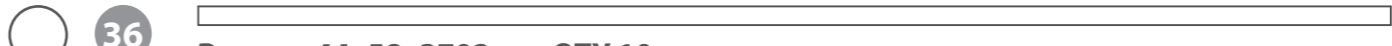

Bearer - 44x58x3702mm QTY 10
F4444-3702-PT



Purlin - 45x120x4004mm QTY 3
F45120-A-4004



Eaves Frame - 27x44x2002mm QTY 4
F2744-2002



Fascia - 16x120x1601mm QTY 4
S16120-G-1601 (Angled)



Fascia - 16x120x2020mm QTY 4
S16120-2020



Storm Brace - 27x44x2000mm QTY 8
F2744-2000



Closure Trim - 16x28x2400mm (approx length) QTY 13
S1628-2400

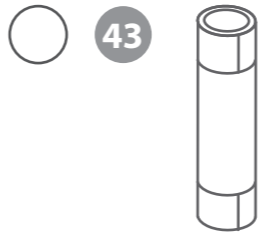

Felt







44

Roof Spacers QTY 5
PI-07-0208 (20x100x2mm)

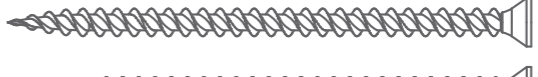
Nail Bag

There may be extra screws present in the nail bag

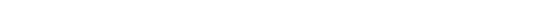
-  **90mm Bolt Set x 16**
-  **90mm Screw x 32**
-  **80mm Screw x 24**
-  **70mm Screw x 38**
-  **40mm Screw x 556**
-  **30mm Screw x 176**
- **Felt Tacks x 300**

Pre-assembly

*Please note:

Each board interlocks at either end in a staggered pattern.

Before securing ensure that the boards are fitted properly in their respective tongues and grooves.

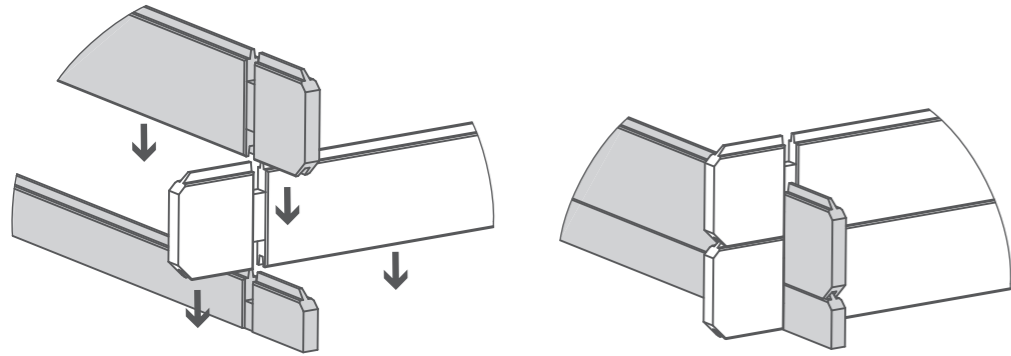

Step 1

Parts Needed - No. 35 QTY 2
No. 36 QTY 2

Lay the bearers (No's. 35 & 36) onto a firm and level surface (**free from areas where standing water can collect**) as shown in the illustration.

Fix the bearers together at each corner with 2 screws per corner using 8x90mm screws, ensuring the bearer is flush.

Once fully assembled, ensure the bearers are square by measuring from corner to corner as illustrated, making sure the measurements are equal.

If the bearers are not aligned equally, unscrew, adjust and re-align accordingly.

8x90mm Screws

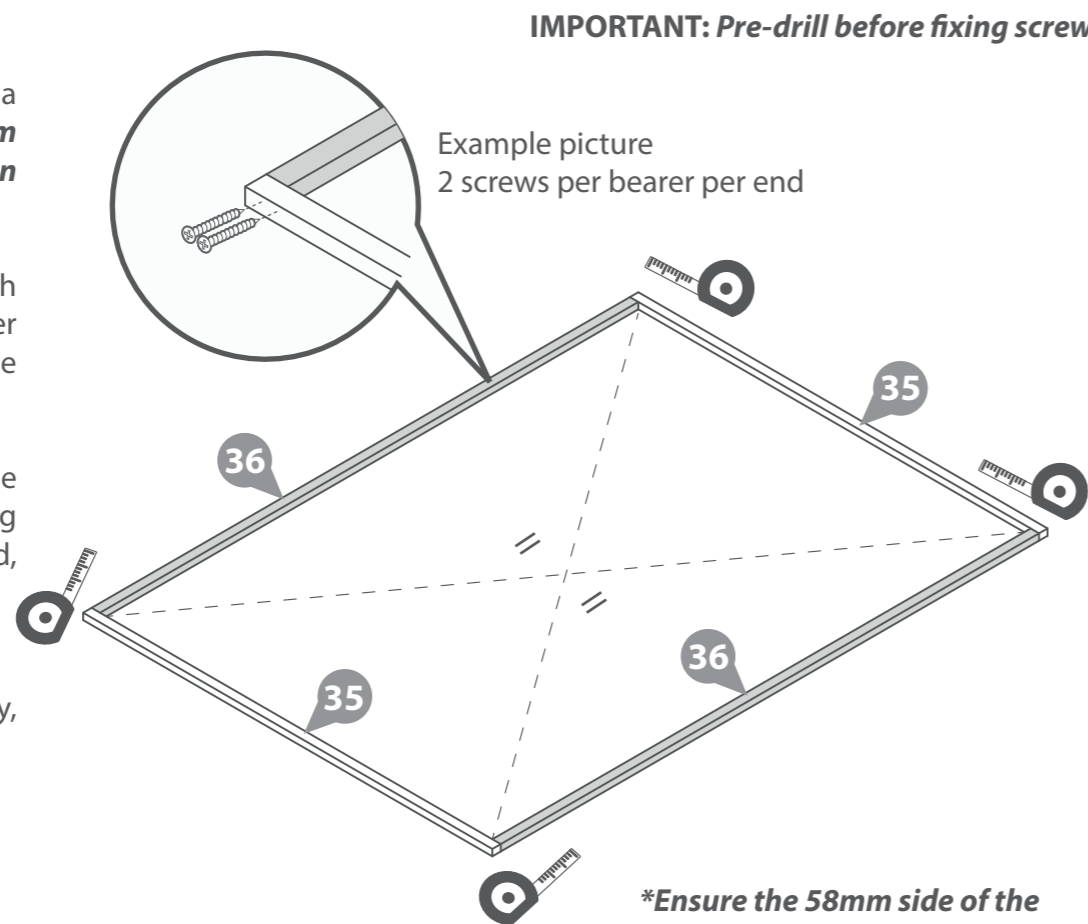

***Ensure the 58mm side of the bearer is laying on the base, so that you can screw the bearers together on the 44mm side.**

IMPORTANT: Pre-drill before fixing screws.

Step 2

Parts Needed - No. 36 QTY 8

Following the same method arrange the remaining bearers (No. 36) inside the assembled frame.

***Ensure there is an equal amount of space between each frame.**

Secure each of the frames in place using 2x90mm screws for each side of the bearer, ensuring the bearers remain level.

32x90mm Screws

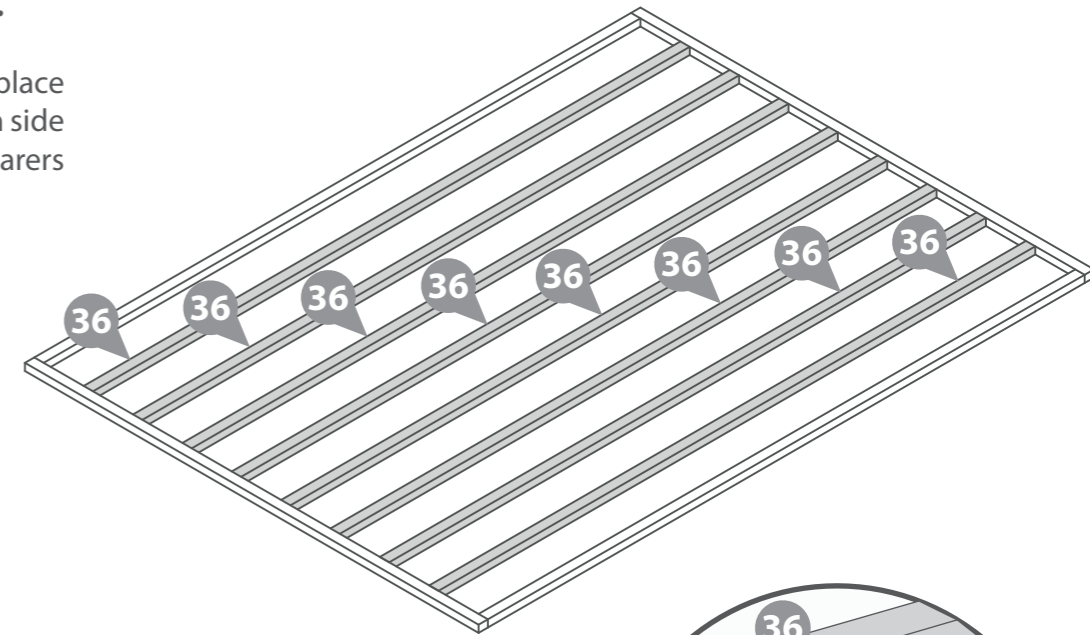

Example picture
2 screws per bearer per end

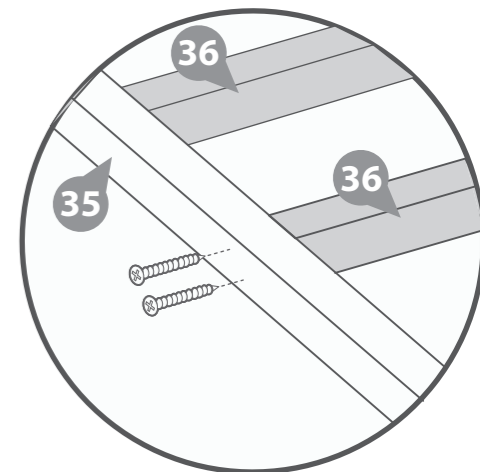

Step 3

Parts Needed - No. 24 QTY 2
No. 25 QTY 2

Place the starter boards (**No's. 24**) on to assembled base frame along the longest sides and place the first two log boards (**No.25**) in the notch as shown.

Ensure the boards sit square on the base using the same method used in Step 1. Measure corner to corner, making sure the measurements are equal.

Once the boards are square, lift up the log board (**No.25**) and fix the starter boards in place.

Fix each of the starter boards to the frame by screwing through the notch into the frame as shown in the illustration.

IMPORTANT: Pre-drill before fixing screws.

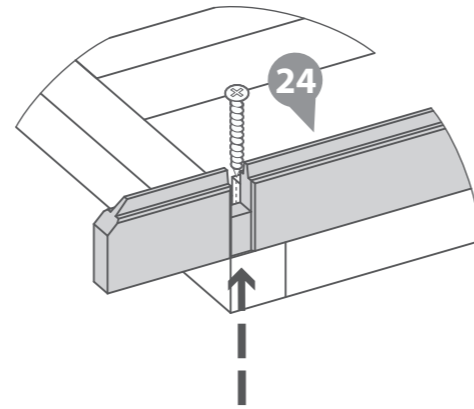

4x70mm Screws

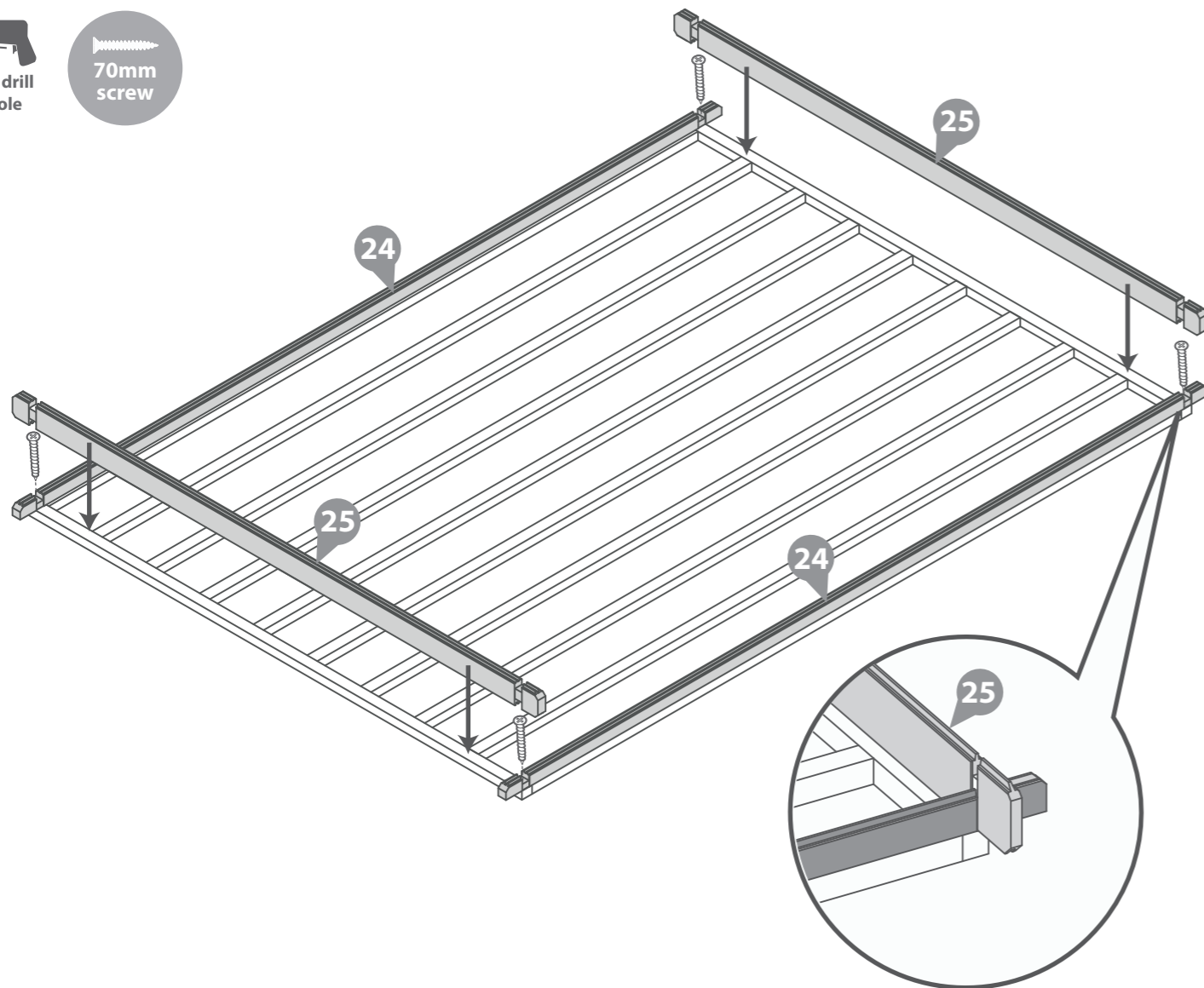

Step 4

Parts needed - No. 25 QTY 12
No. 26 QTY 6
No. 27 QTY 6
No. 30 QTY 6

Following the method shown in the illustration, lay the first 6 boards (**No's. 25, 26, 27 & 30**)

Start by placing the front and back boards, interlocking them with the side boards. Then place the next side boards, interlocking with the front and back boards. Continue this method until you have placed **6 boards off of the starter boards on each side**, as shown in the illustration.

This will create your first level.

***Ensure that the boards are level and flush with each other as you lay each one.**

***Make sure that you have seven rows of log boards (No. 25) in total below the window side.**

Please Note: The short boards at the front of the building (either side of the door and window opening's) can be placed either side depending on your needs.



IMPORTANT: Pre-drill before fixing screws.

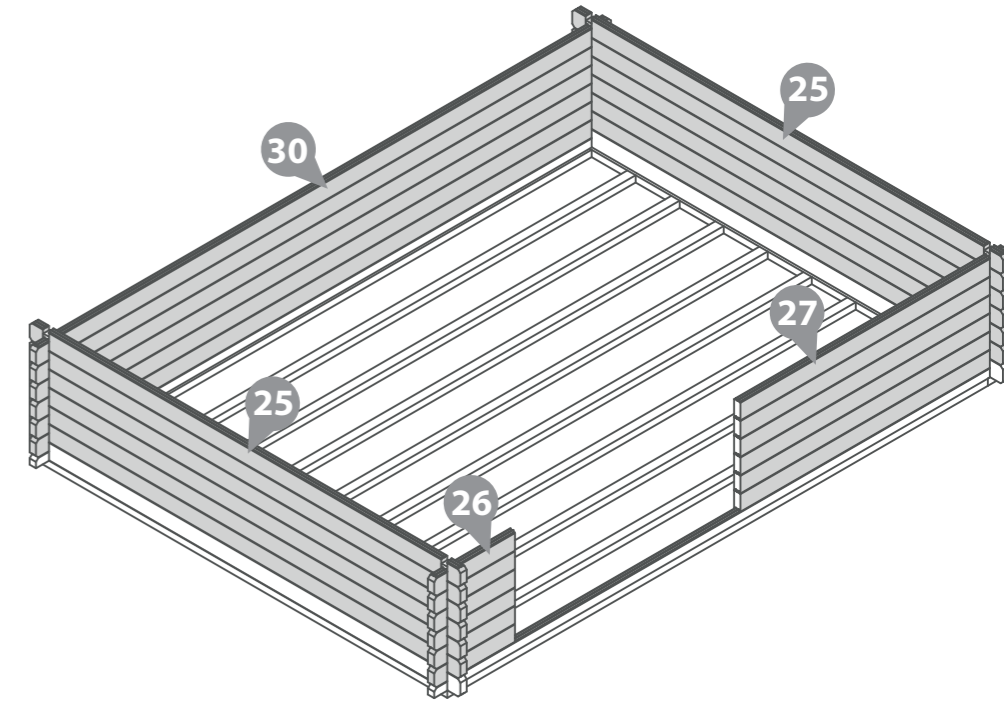
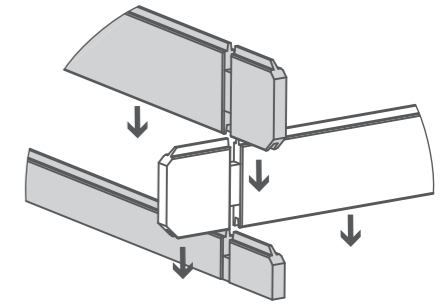

Step 5

**Parts Needed - No. 11 QTY 1
No. 12 QTY 1
No. 13 QTY 1
No. 14 QTY 1**

Arrange the left, right, top & bottom door frames (No's. 11, 12, 13 & 14) onto a level surface. Secure the top and bottom frames to the uprights using 2x80mm screw per corner, ensuring the screws do **NOT** protrude through the front of the door framing.

8x80mm Screws

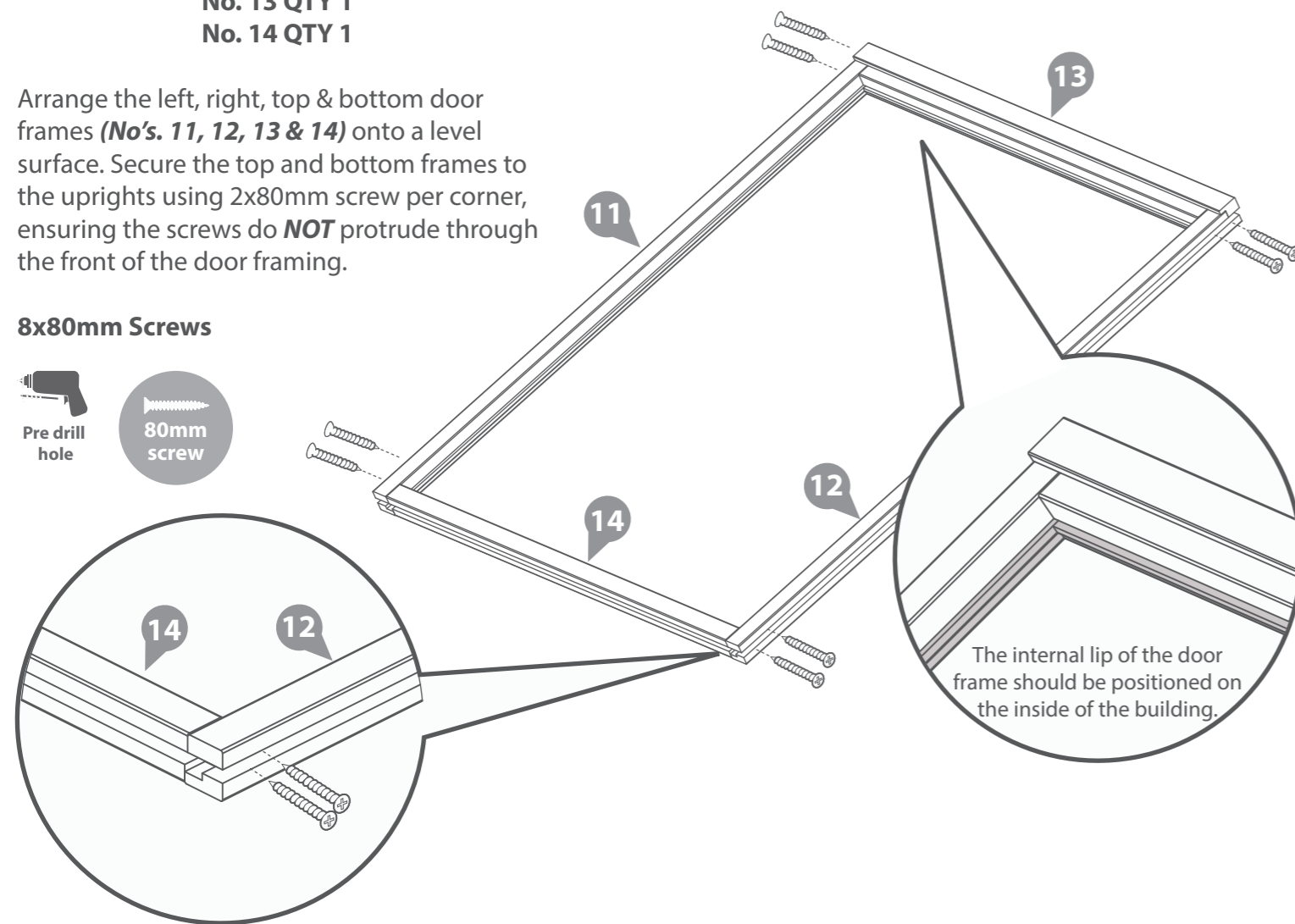

IMPORTANT : Pre-drill before fixing screws.

Step 6

**Parts Needed - No. 9 QTY 1
No. 10 QTY 1
No. 17 QTY 6**

a The Adjustable Door Hinge (No.17) comes in three parts.

Fasten No. 17a into 17b as shown in the illustration.

b Place the master and secondary doors (No's 9 & 10) onto a flat surface and fix the Adjustable door hinge (No.17c) to the doors using 3x30mm screws per hinge.

Fix 3 x Adjustable Door Hinges (No. 17a & b) into position onto the door frame using 4x30mm screws per hinge.

***Ensure the hinges are fitted to the external of the door frame so the doors open outwards from the log cabin.**

Locate the doors into the hinges ensuring there is equal spacing on each side between the doors and door frame, and that the doors open & close freely without restriction.

It is important to fit the doors within the frames at this stage so that you can establish the position of the hinges. The hinges come in three parts. Remove the doors from the frame after fitting.

****Ensure to screw into the framing and not into the channel.**

42x30mm Screws



IMPORTANT : Pre-drill before fixing screws.

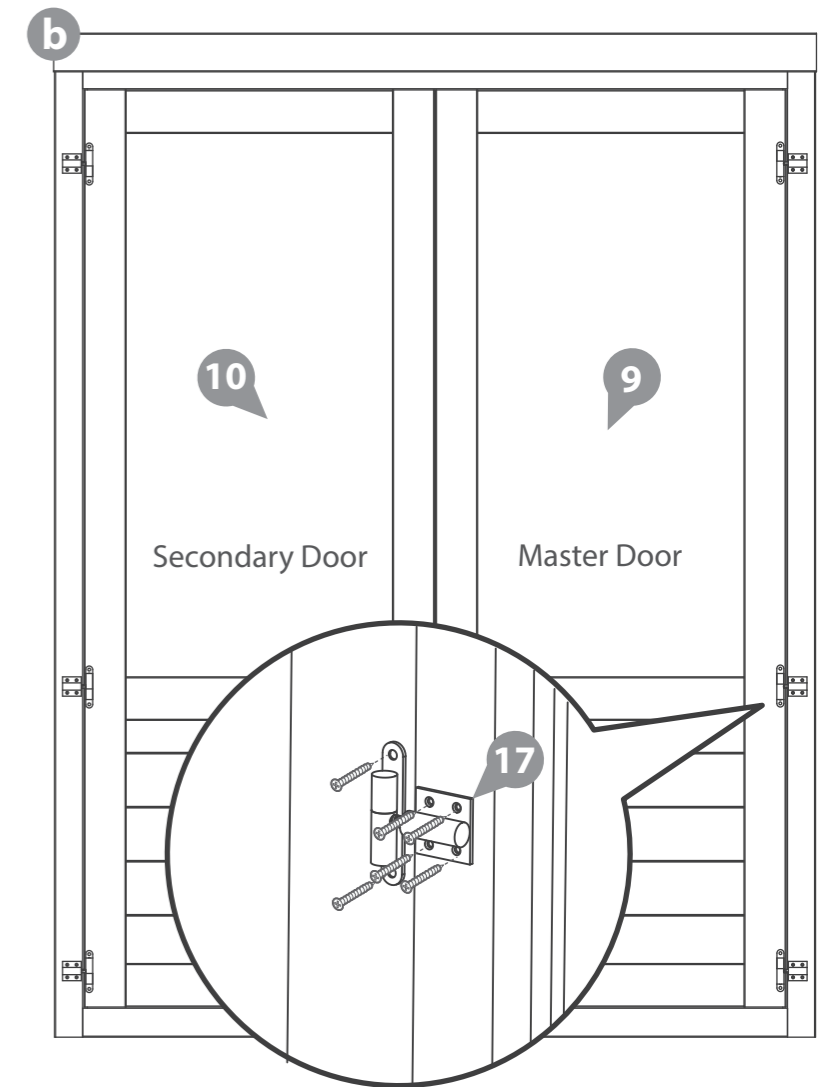
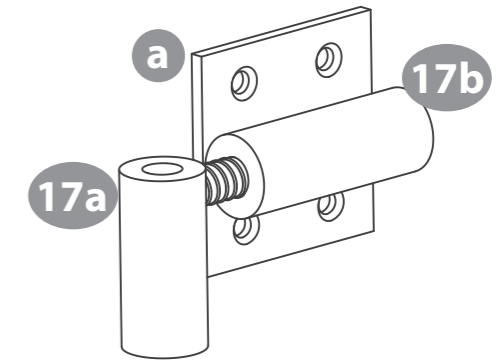

Step 7

To adjust and align your doors:

1. Lift up the doors to separate the two parts of the hinge.
2. Turn the rotating barrel (**No.17a**) in / out to move the position of the doors either in or away from each other.
3. You can then place the door(s) back on to the hinge and check whether they require more / less adjustments, if further adjustments are required repeat number 2.

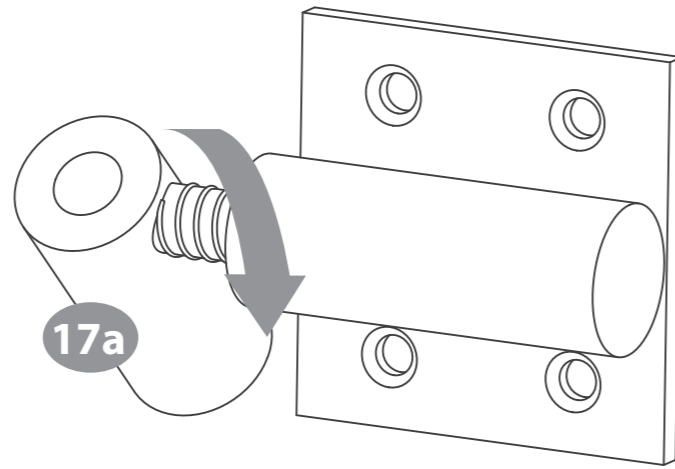

Step 9

- Parts needed - No. 25 QTY 6
 No. 26 QTY 12
 No. 28 QTY 6
 No. 29 QTY 12
 No. 30 QTY 6

Following the method shown in the illustration, lay the next 6 boards (**No's. 25, 26, 28, 29 & 30**) onto the log cabin to create your second level.

***Ensure that the boards are level and flush with each other as you lay each one.**

***Make sure that you have seven rows of log boards (No. 25) in total below the window side.**

****Please Note:** The short boards placed to create the opening's for the doors & windows can be placed either side depending on your needs.

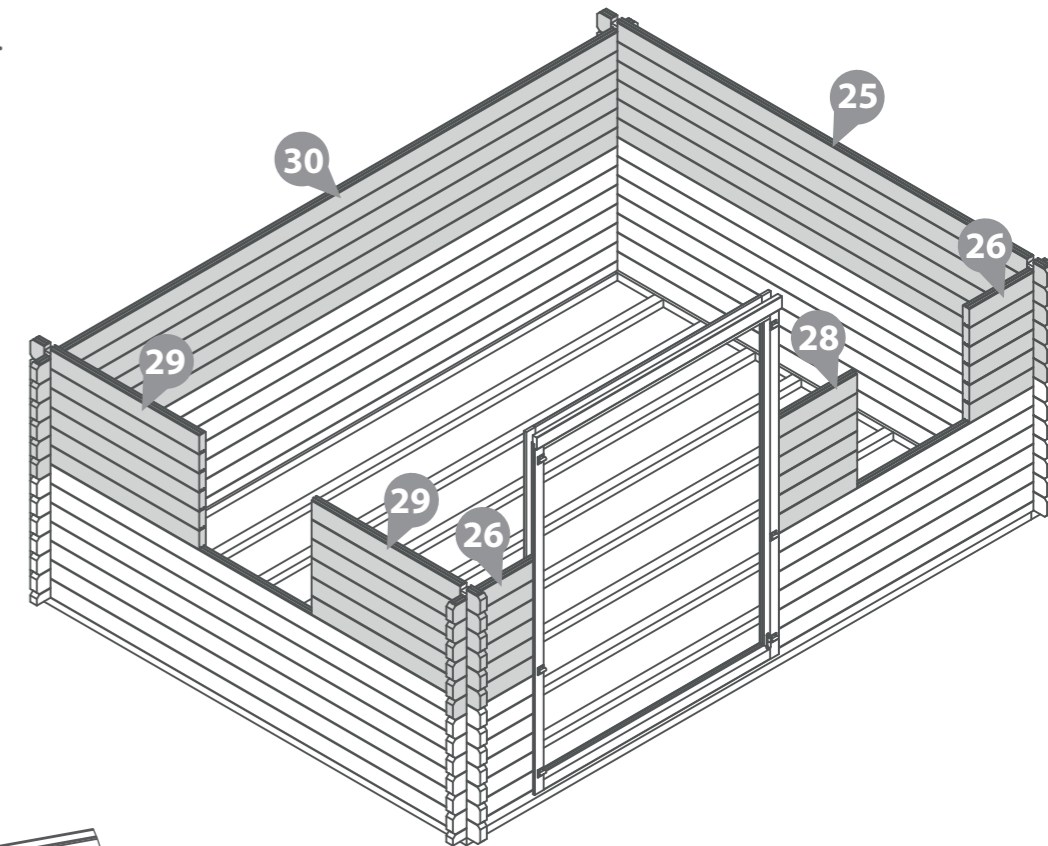

Rubber Mallet may be required to fit parts.

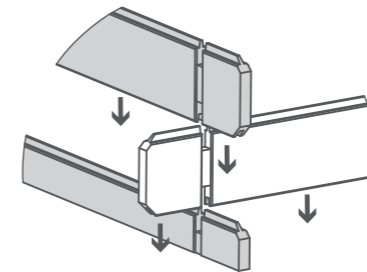

Step 8

Once you have laid 6 log boards (on top of the starter board) up the door section, slide the assembled door frame (**without main doors**) over the boards, resting the frame on top of the starter board. If you have not yet assembled the door frame, please refer to **Step 5**.

***Please note:** This image is for illustrative purposes and may differ from your choice in product (**regarding door position**). Nevertheless the process of fitting the door frame is the same.

****Please Note:** The short boards at the front of the building (either side of the door and window opening's) can be placed either side depending on your needs.

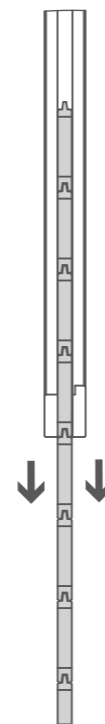
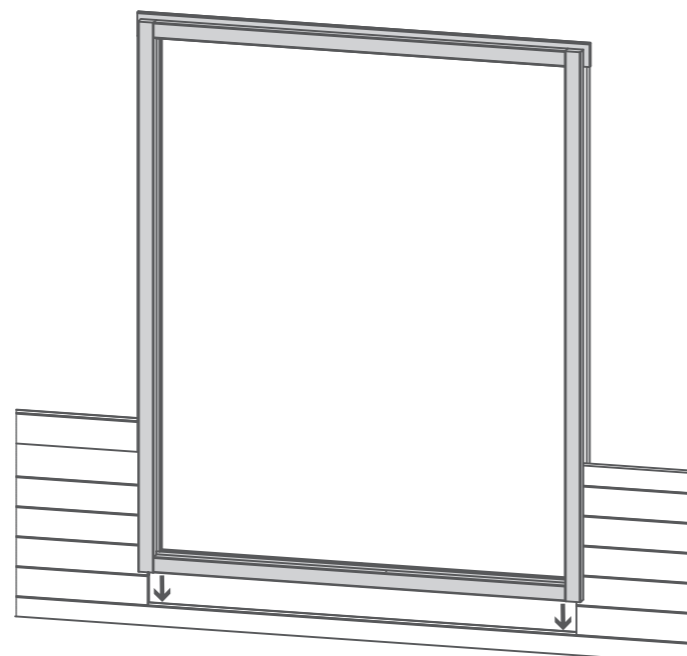

Step 10

- Parts Needed - No. 2 QTY 2
 No. 3 QTY 2
 No. 4 QTY 2
 No. 5 QTY 2

Arrange the left, right, top & bottom window frames (No's. 2, 3, 4, & 5) onto a firm and level surface. Secure the top and bottom frames to the uprights using 2x80mm screw per corner, ensuring the screws do **NOT** protrude through the front of the window framing.

Use this method to assemble 2 window frames.

16x80mm Screws



IMPORTANT : Pre-drill before fixing screws.

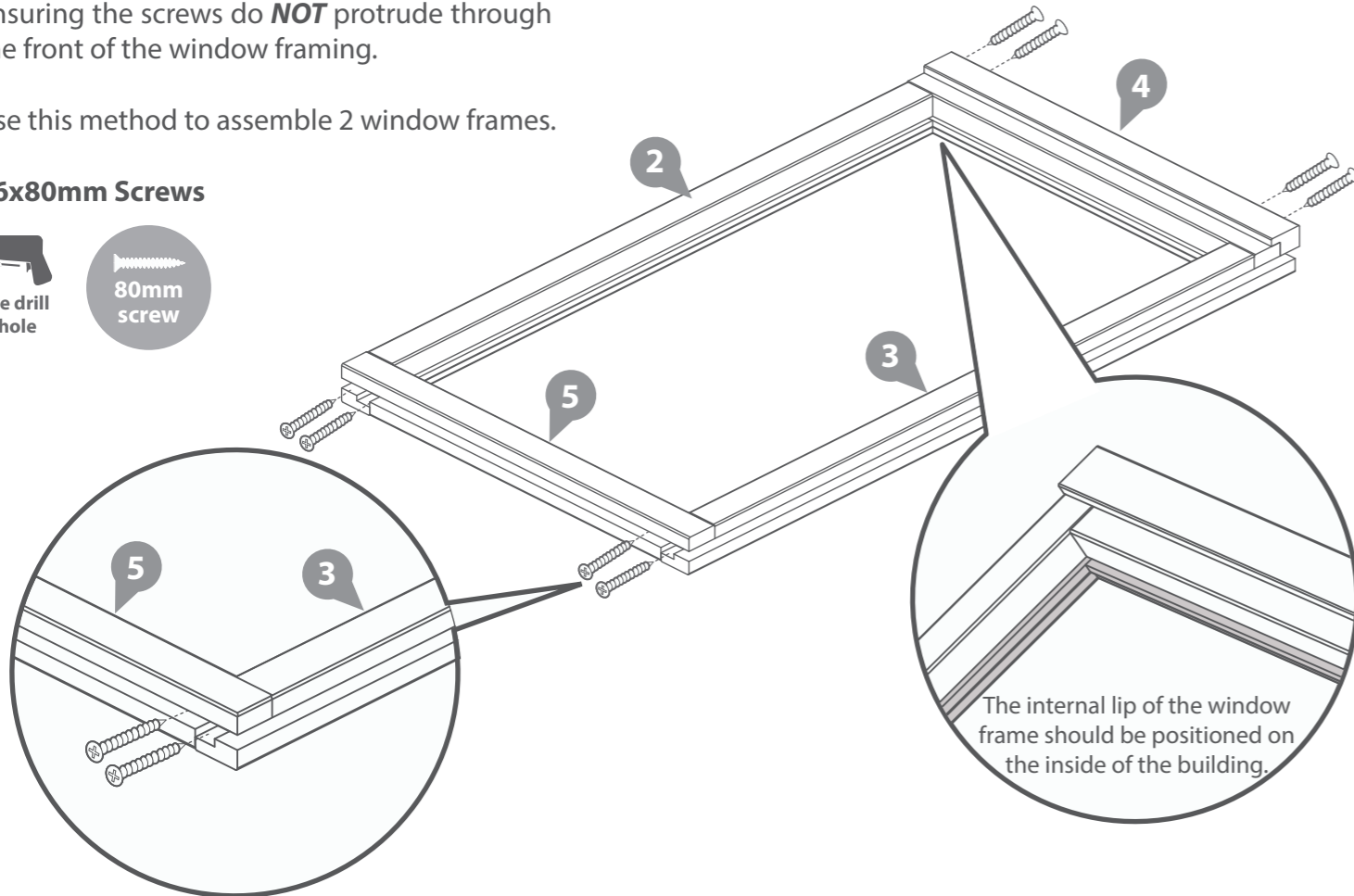

Step 11

- Parts Needed - No. 1 QTY 2
 No. 7 QTY 4

Position the window (No. 1) so that it sits centrally within the window frame. Fix the female part of the flag hinge (No. 7) to the window using 4x30mm screws, attach the male part of the flag hinge (No. 7) to the window frame using 4x30mm screws ensuring that the window can open and close freely.

Ensure to attach the hinge to the horizontal frame of the window

Repeat this method for both windows

****It is important to fit the windows within the frame at this stage so that you can establish the position of the hinges. The hinges come in two parts. Remove the window from the frame after fitting.**

32x30mm Screws

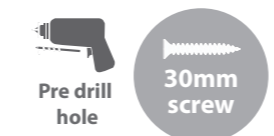

IMPORTANT : Pre-drill before fixing screws.

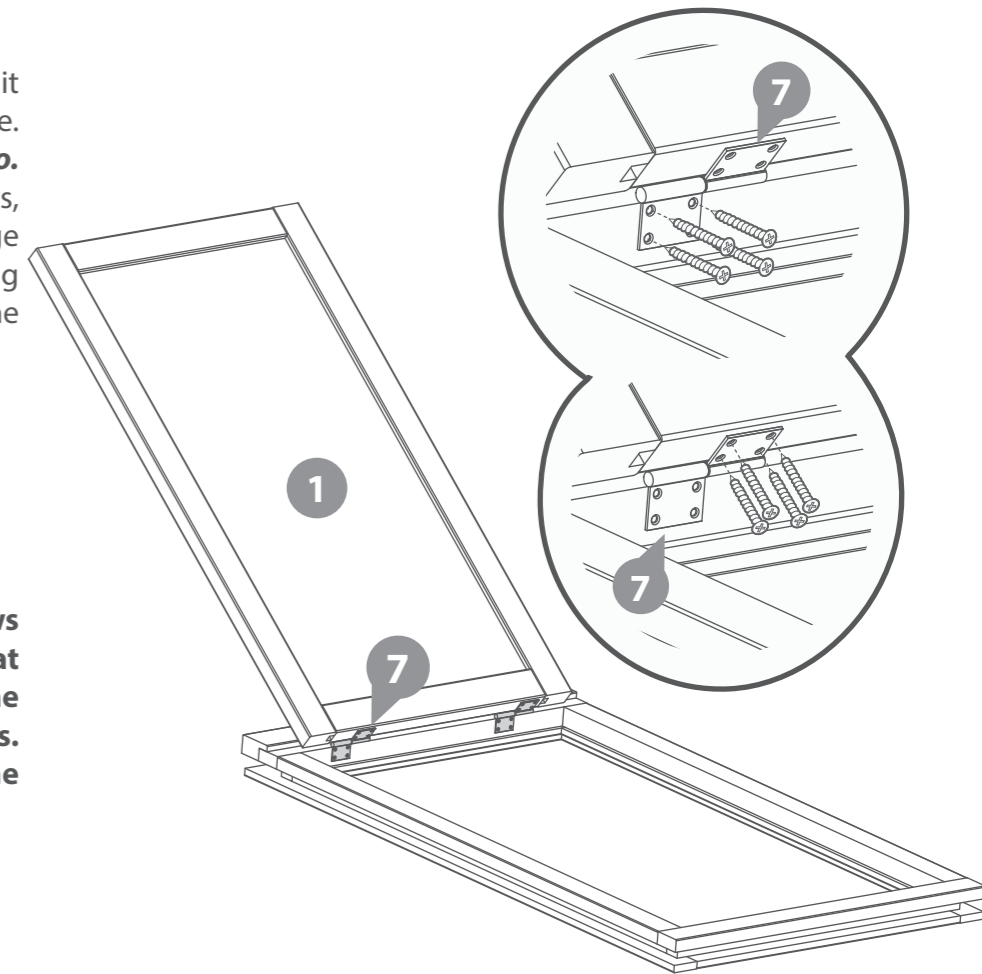

Step 12

Once you have laid the second level of boards onto the log cabin, slide the windows between the smaller boards and rest on to the longer board. If you have not yet assembled your windows, please refer to **Steps 10**.

***Ensure the boards are level with each end.**

***Please note:** This image is for illustrative purposes and may differ from your choice in product (regarding window position). Nevertheless the process of fitting the window is the same

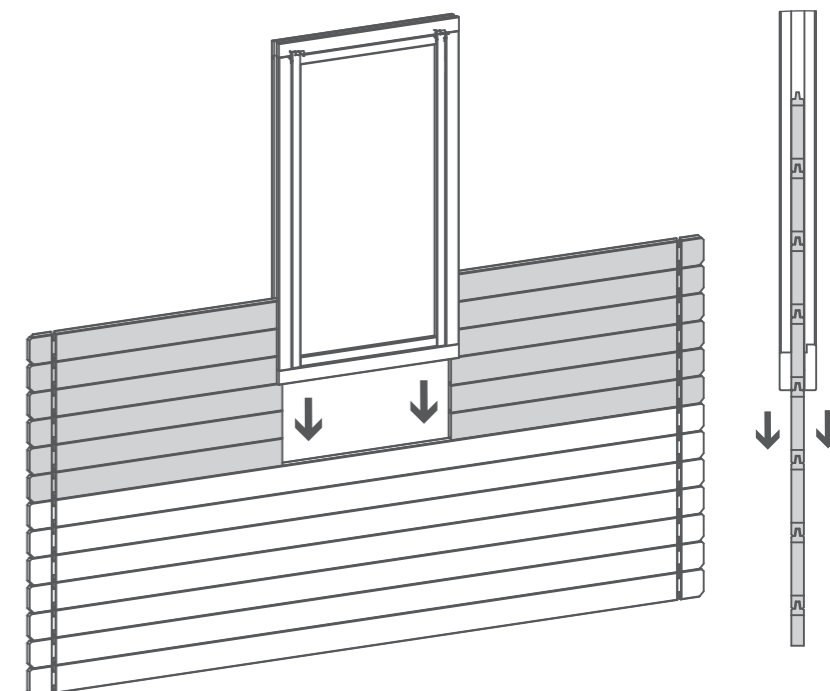

Step 13
Parts needed - No. 25 QTY 6
No. 26 QTY 12
No. 28 QTY 6
No. 29 QTY 12
No. 30 QTY 6

Following the method shown in the illustration, lay the remaining boards (No's. 25, 26, 28, 29 & 30) onto the log cabin to bring the board level to the top of the window and door frames.

**Ensure that the boards are level and flush with each other as you lay each one.*

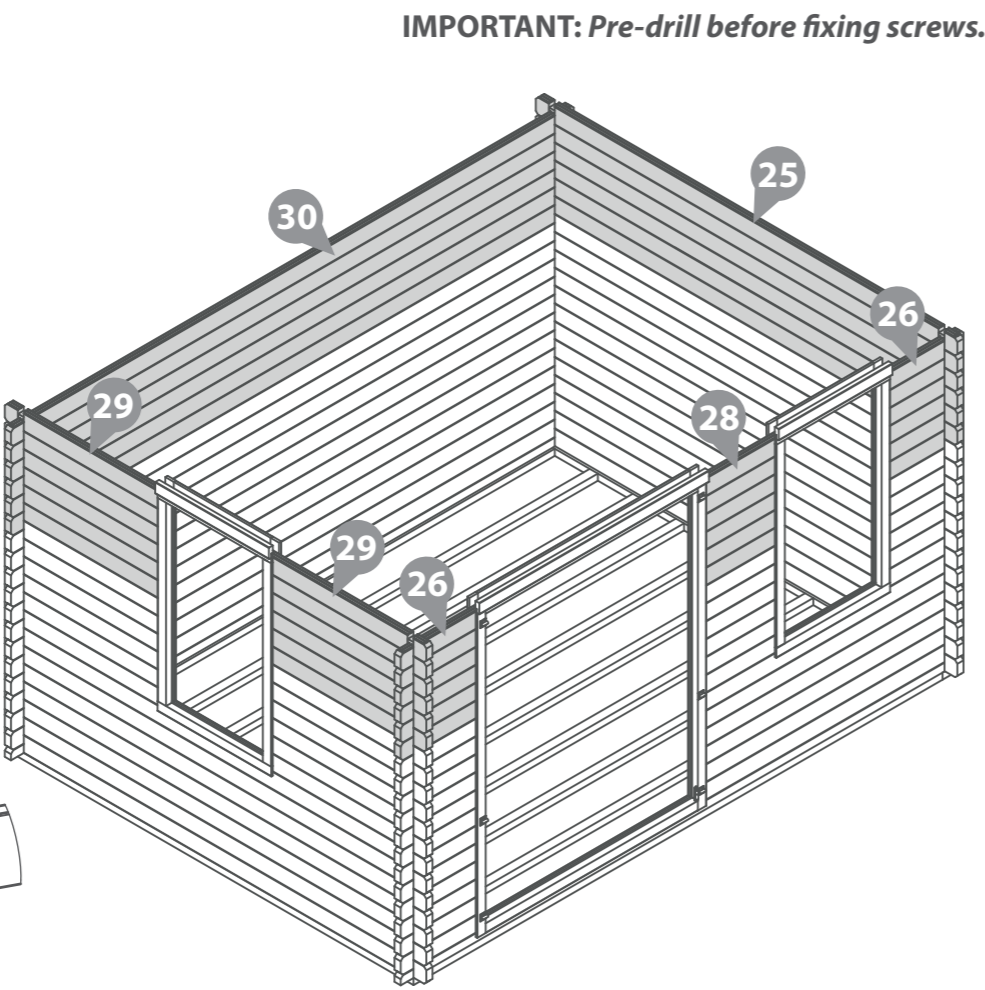
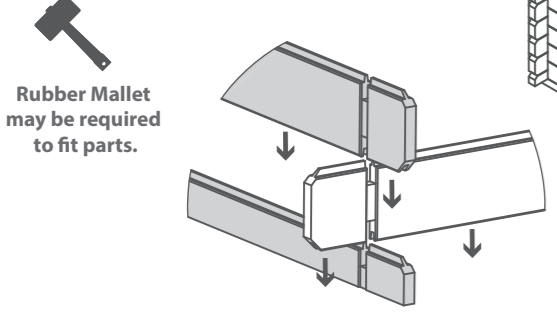

Step 15
Parts needed - No. 22 QTY 1
No. 23 QTY 1

Place the gable tops (No.22 & 23) onto the log cabin. Fix into position by screwing through the notches as shown in the illustration.

**Ensure that the boards are level and flush with each other as you lay each one.*

4x70mm Screws

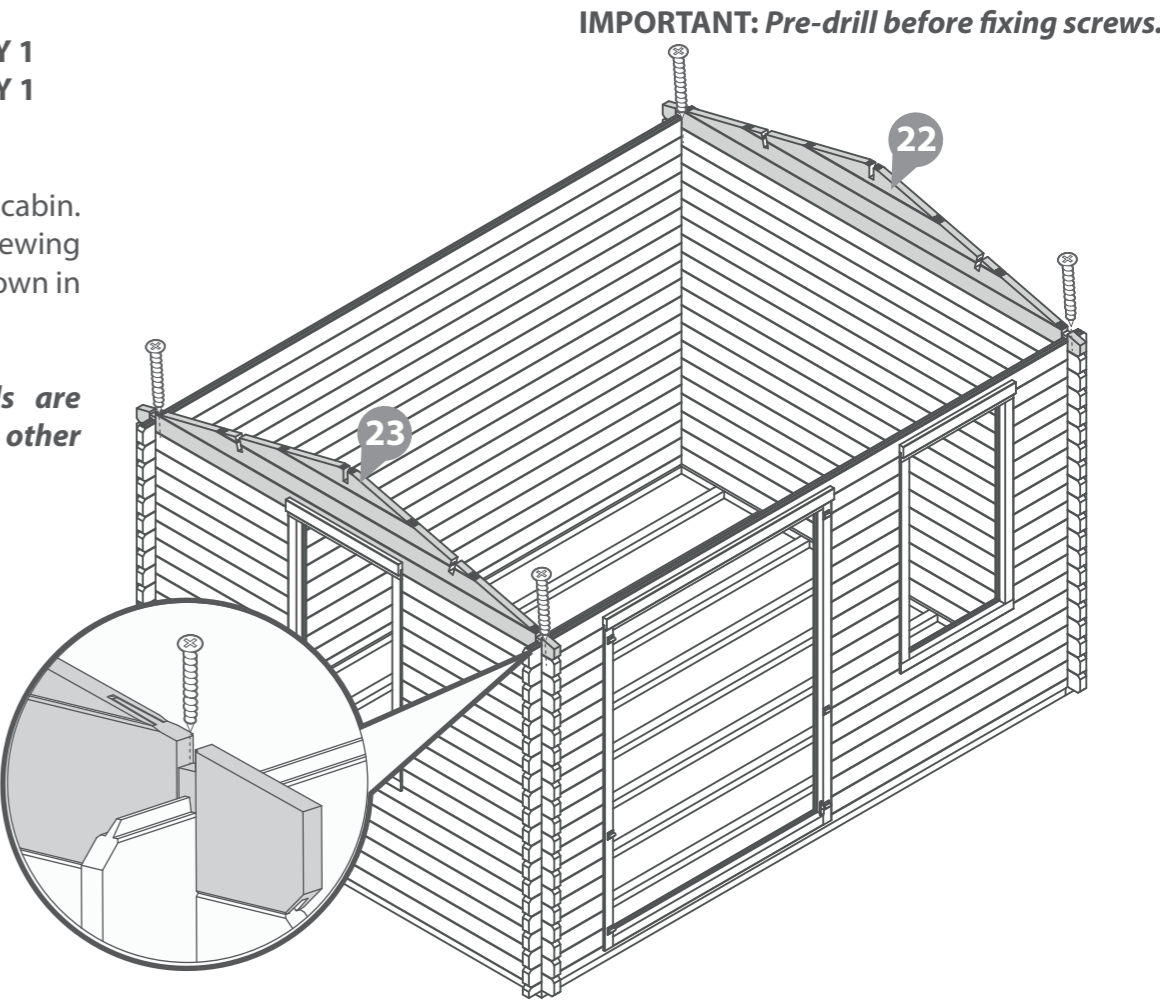
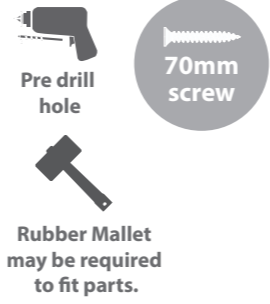

Step 14
Parts needed - No. 30 QTY 1
No. 32 QTY 1

Following the method shown in the illustration, lay the last boards (No's. 30 & 32) on to the log cabin, fixing into position by screwing through the notches as shown in the illustration.

**Ensure that the boards are level and flush with each other as you lay each one.*

4x70mm screws.

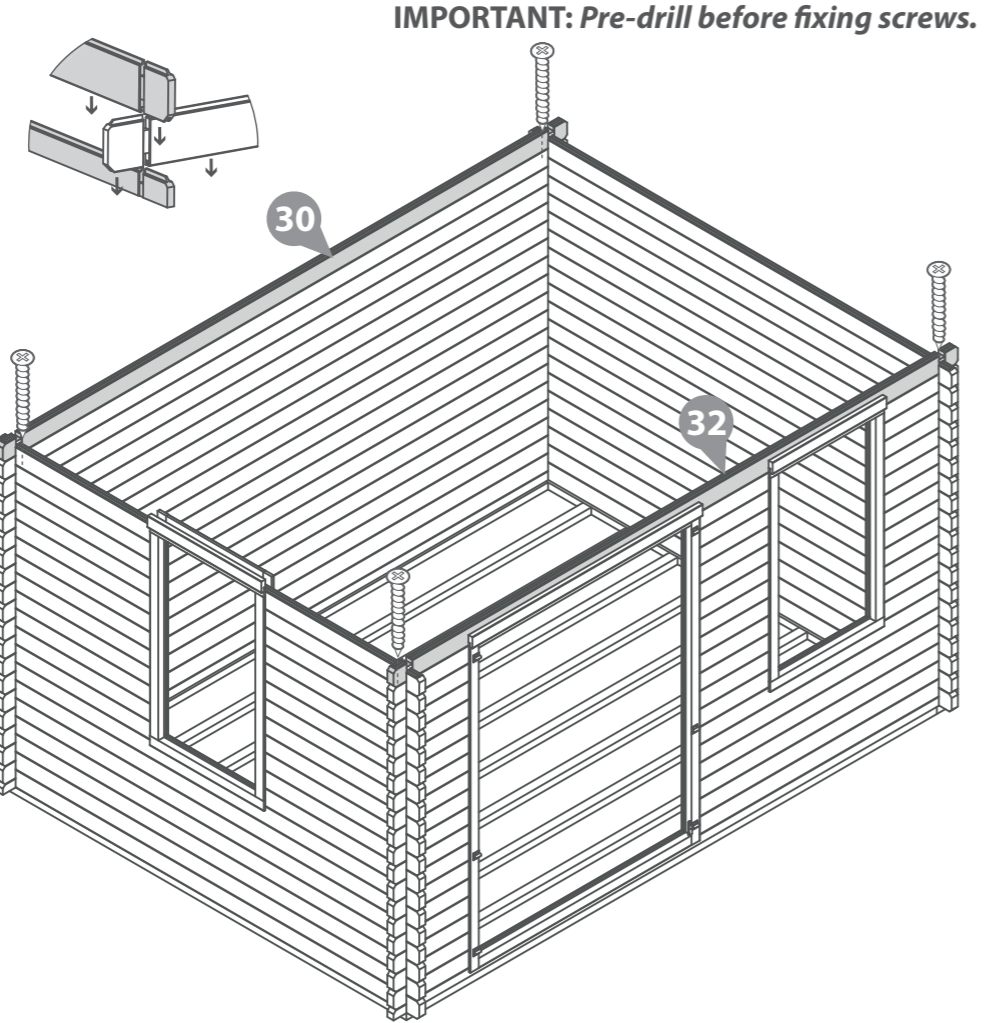
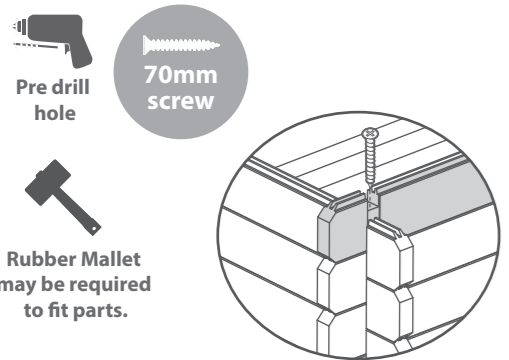

Step 16
Parts needed - No. 31 QTY 2

Place the Finisher Boards (No. 31) onto the building. Secure into position at either end by screwing through the notch into the board below.

**Ensure that the boards are level and flush with each other as you lay each one.*

4x70mm Screws

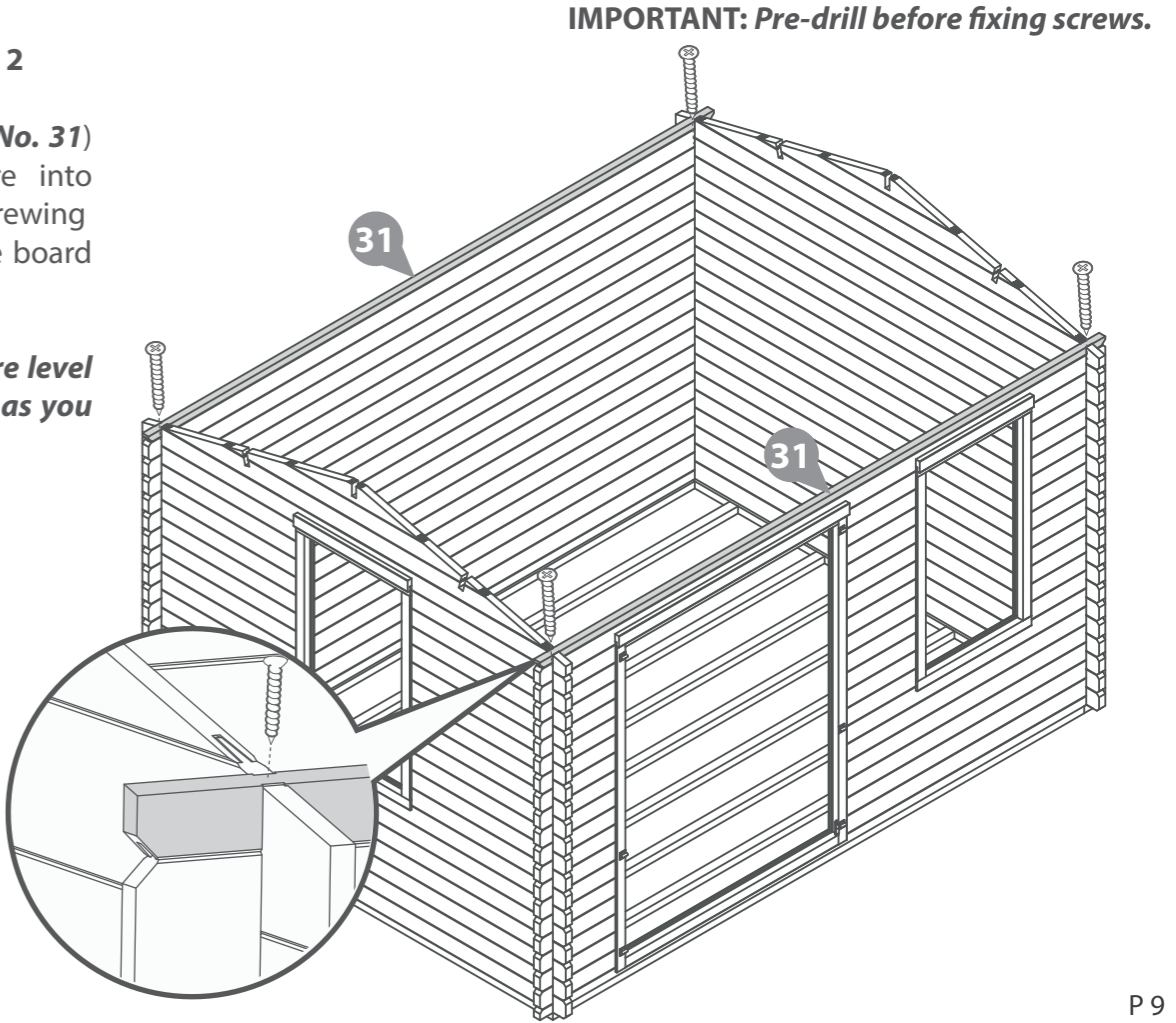
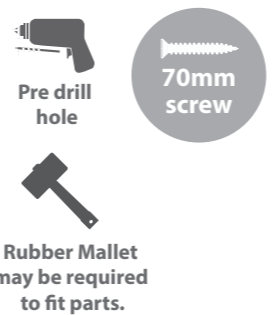

Step 17

Parts needed - No. 37 QTY 3

a Align the Roof Purlin(s) (No. 37) into the cut out slots on each gable top ensuring each purlin interlocks the boards.

b Secure the purlin at each end by screwing through the purlins into the boards (ensure to pre-drill to avoid the boards splitting) using 4x70mm screws per purlin.

**Please note: The gable shown is for illustrative purposes and may differ in width from your choice in product. Nevertheless, despite any differences the process of fixing the purlins is the same.*

12x70mm Screws

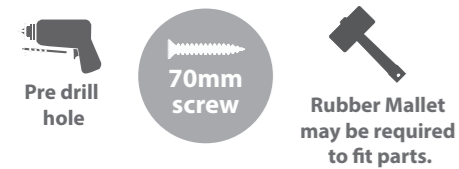

IMPORTANT: Pre-drill before fixing screws.

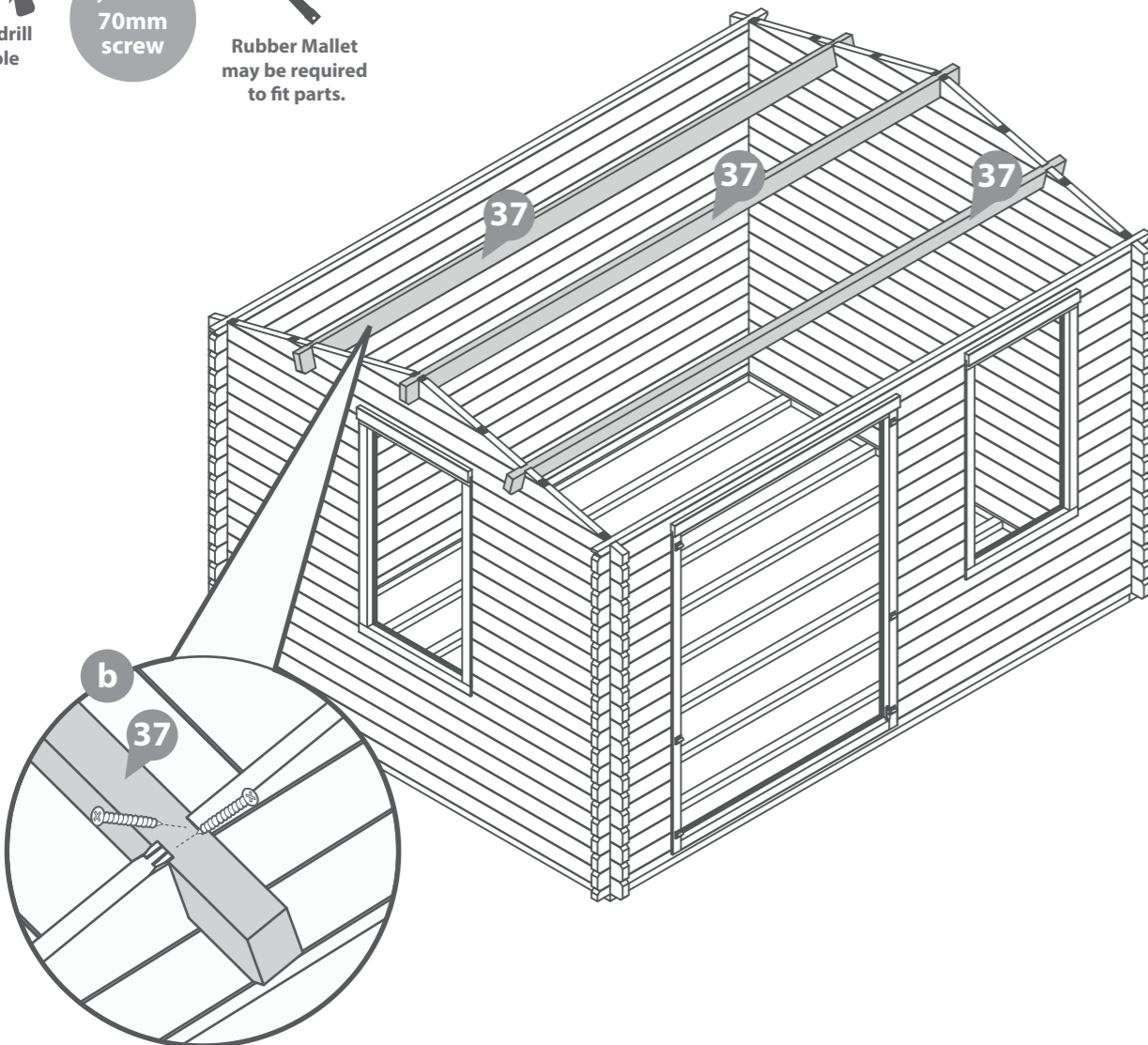
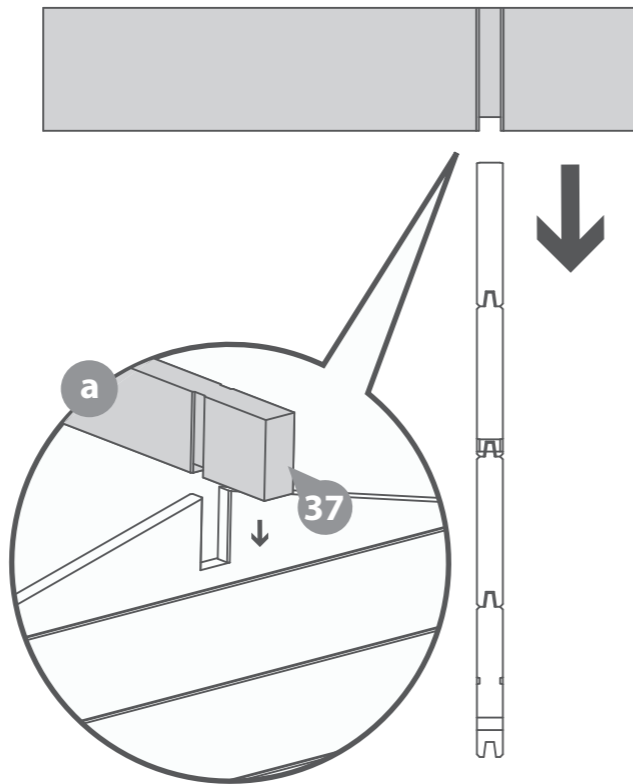

Step 18

Parts needed - No. 33 QTY 74

a Place the first two roof board's (No.33) onto either side of the log cabin, making sure the boards are flush to the end of the roof purlin. Once in position fix to each purlin using 3x40mm screws.

**Ensure the roof boards meet at the top of the apex and leave an overhang at the bottom.*

Continue adding the roof boards along the roof, fixing each one into position using 3x40mm screws, making sure that each board is interlocked, flush at the bottom & meet at the top of the apex.

Ensure the roof boards are not laid too close together, use the spacers (No. 44) provided to create a 2mm gap. Adjusting the spacing between the boards allows the wood to swell in damp weather.

You have been issued with 74 roof boards, but in reality you may only need to use 72.

b The last board on each side will overhang past the end of the roof purlin; Using a straight edge and a pencil mark out a line as a guide.

Cut along the pencil mark and remove the excess. Place the cut down board's back onto the roof and secure into place using 3x40mm screws per board.

**Please Note: This image is for illustrative purposes and may differ from your choice in product. Nevertheless the process of cutting and fitting the last roof board(s) is the same.*

222x40mm Screws

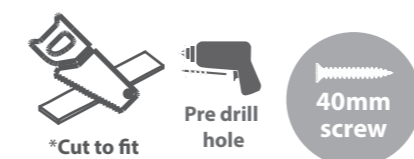

IMPORTANT : Pre-drill before fixing screws.

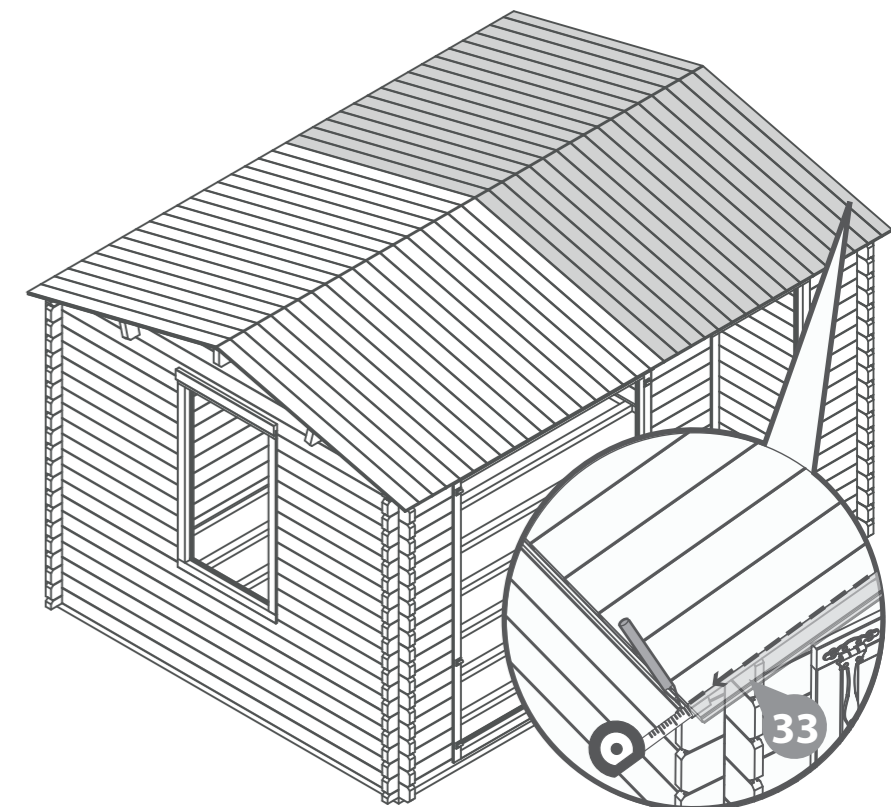
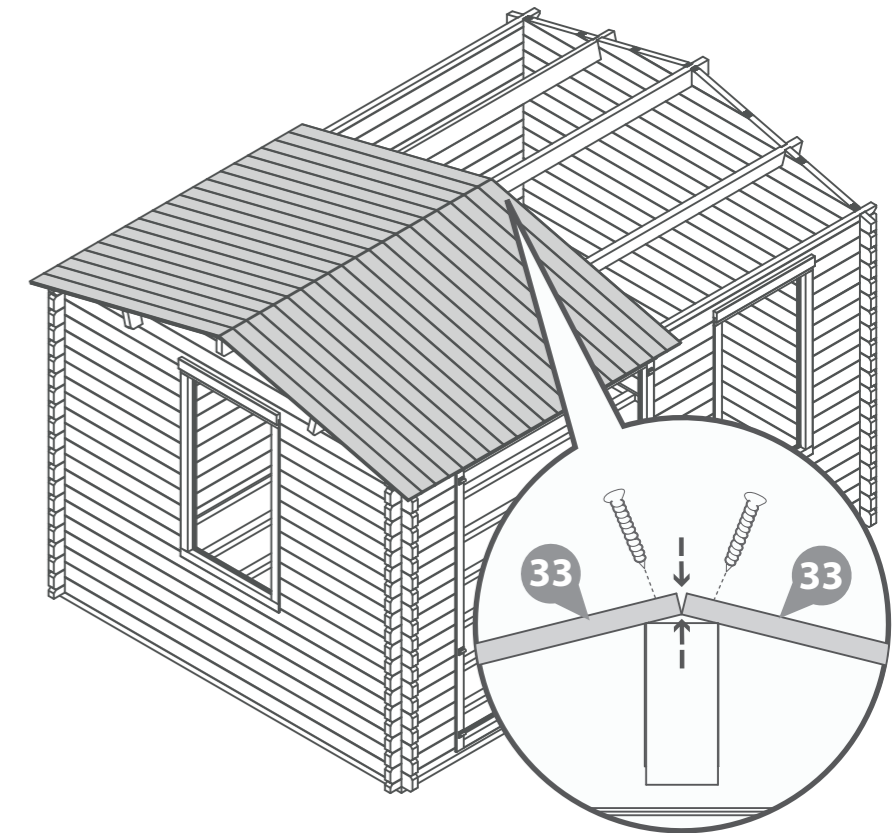

Step 19
Parts needed - No. 38 QTY 4

Ensuring the roof boards are flush at the overhanging side and meet at the apex, fix the Eaves Frames (No. 38) to the underside of the roof boards using 9x40mm screws as shown in the illustration.

**Please Note: This image is for illustrative purposes and may differ from your choice in product. Nevertheless the process of fixing the eaves frames is the same.*

36x40mm Screws

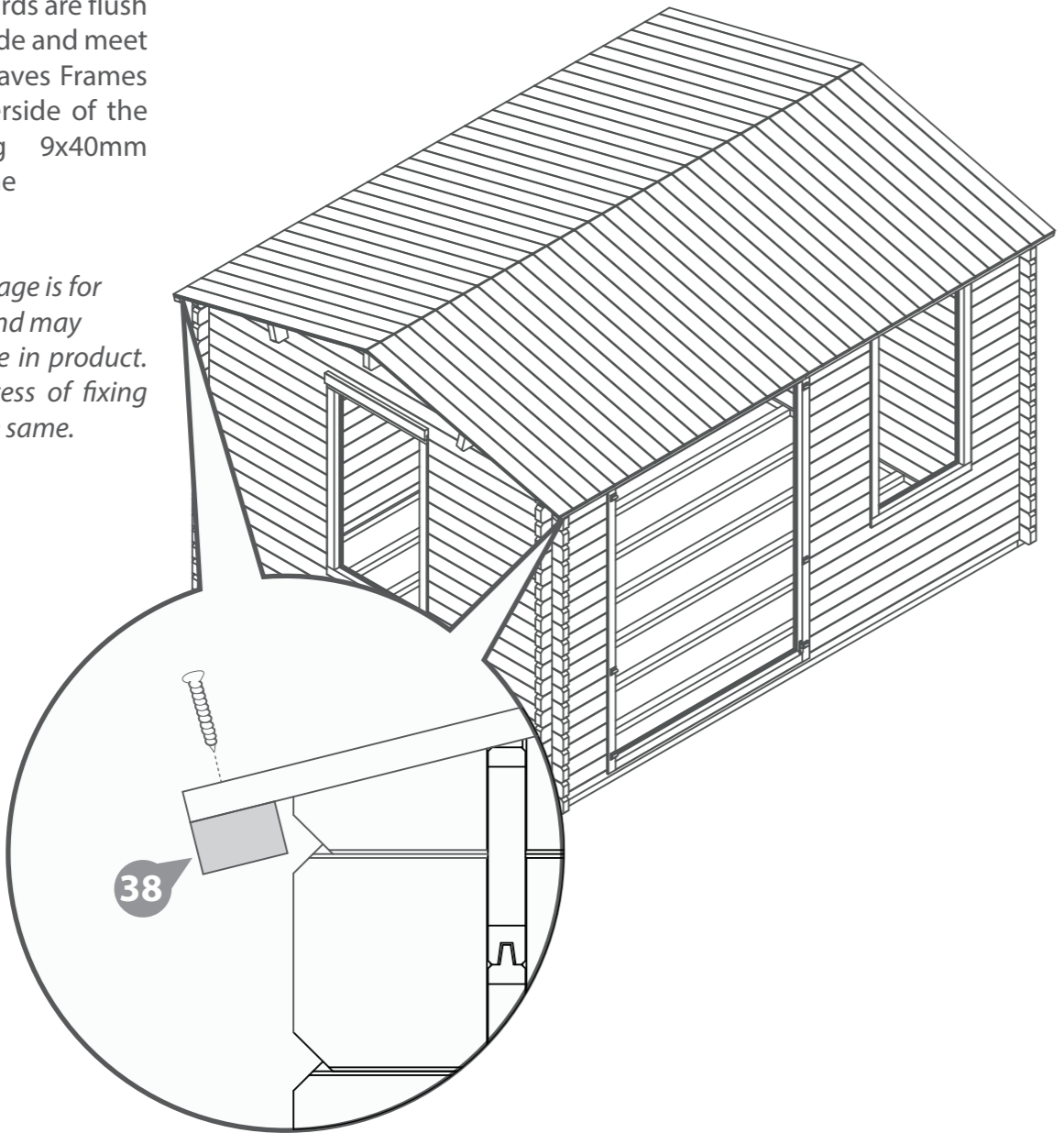
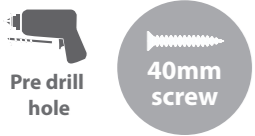

IMPORTANT : Pre-drill before fixing screws.

Step 20

Lift each window onto the already existing hooks on the window frame, ensuring the hook and bands connect.

***Some adjustment may be required to align properly.**

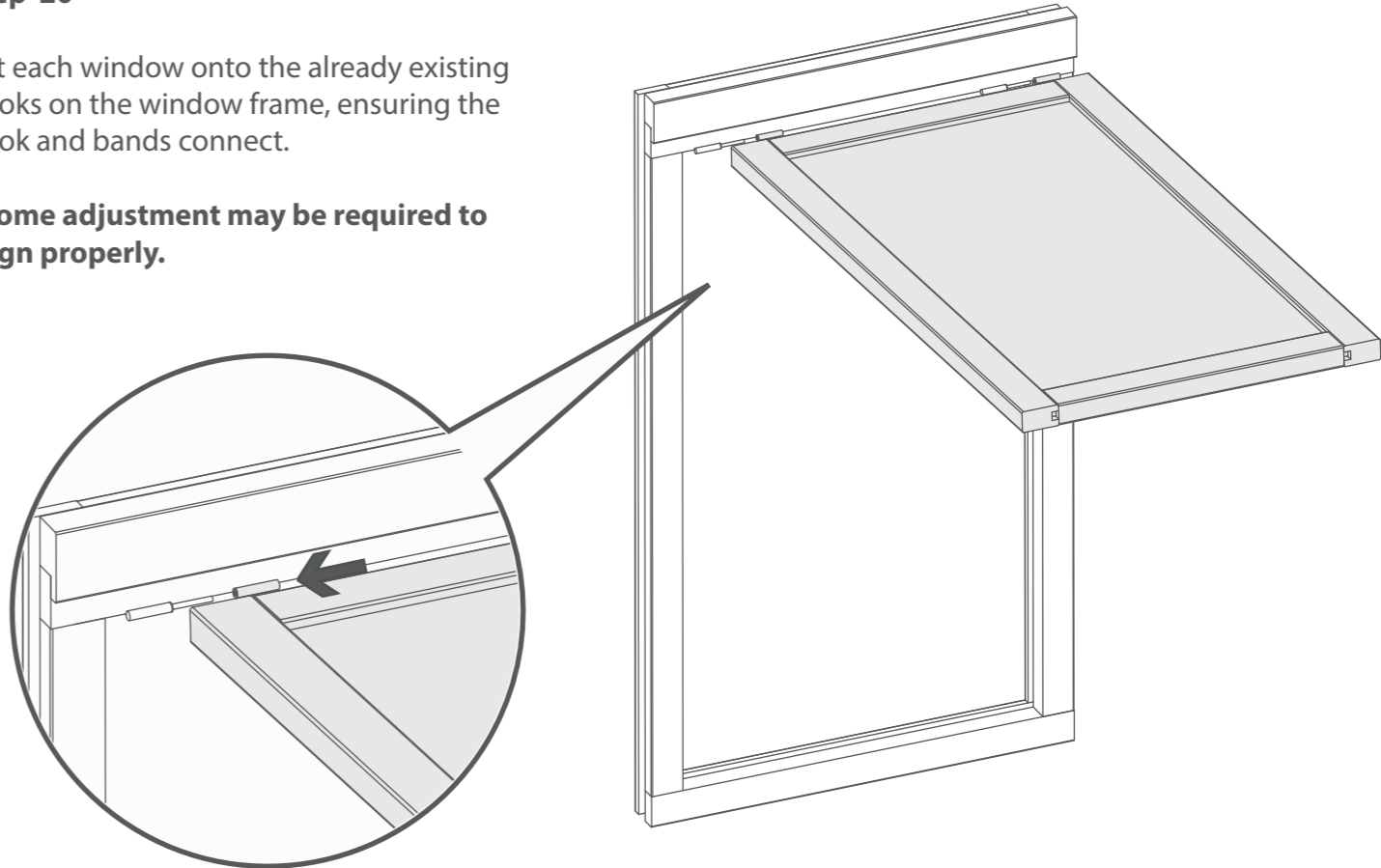

Step 21
Parts Needed - No. 8 Qty 2

Fix the casement stay (No. 8) onto the window (No. 1) and the casement stay pins to the window framing using 6x30mm black screws.

***Ensure the casement stay is centralised on the window and the pins are in line with the pin receivers before fixing in place.**

Repeat this method to fix a casement stay to each window

12x30mm Screws

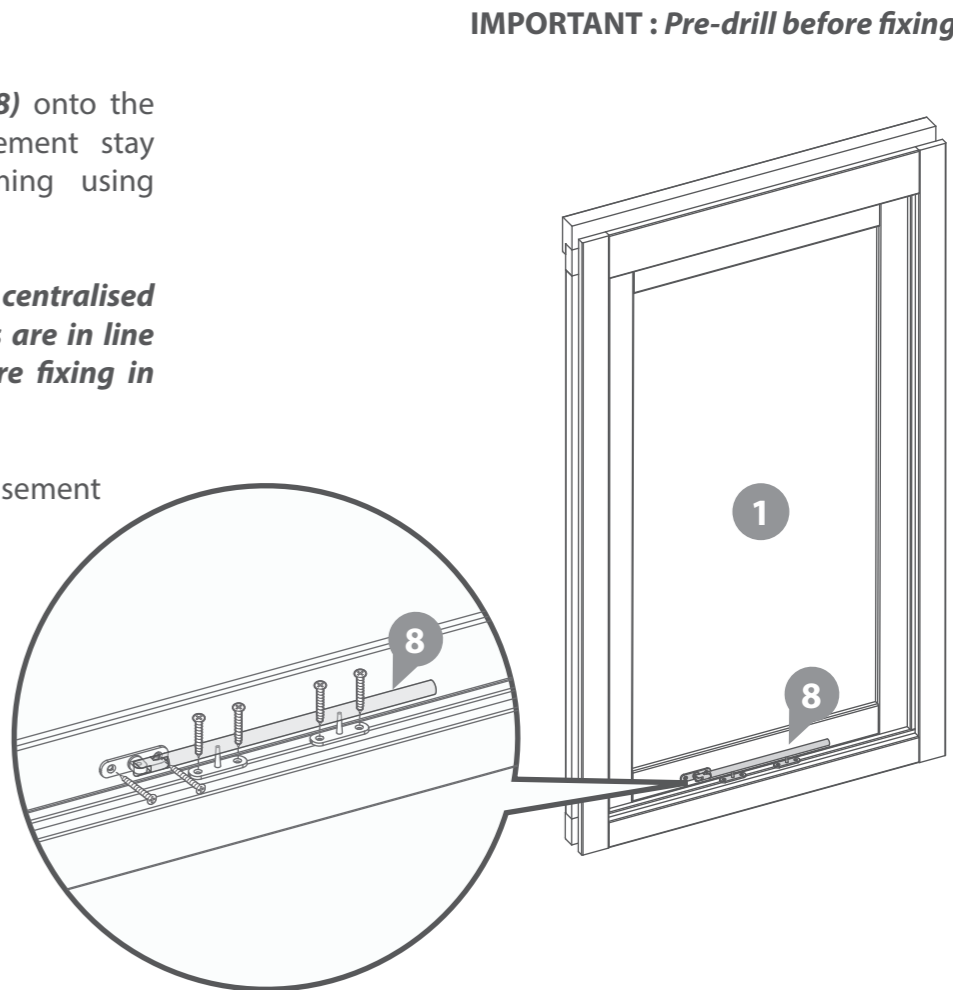

IMPORTANT : Pre-drill before fixing screws.

Step 22

Lift each door onto the already existing hooks on the door frame, ensuring the hook and bands connect.

***Some adjustment may be required to align properly.**

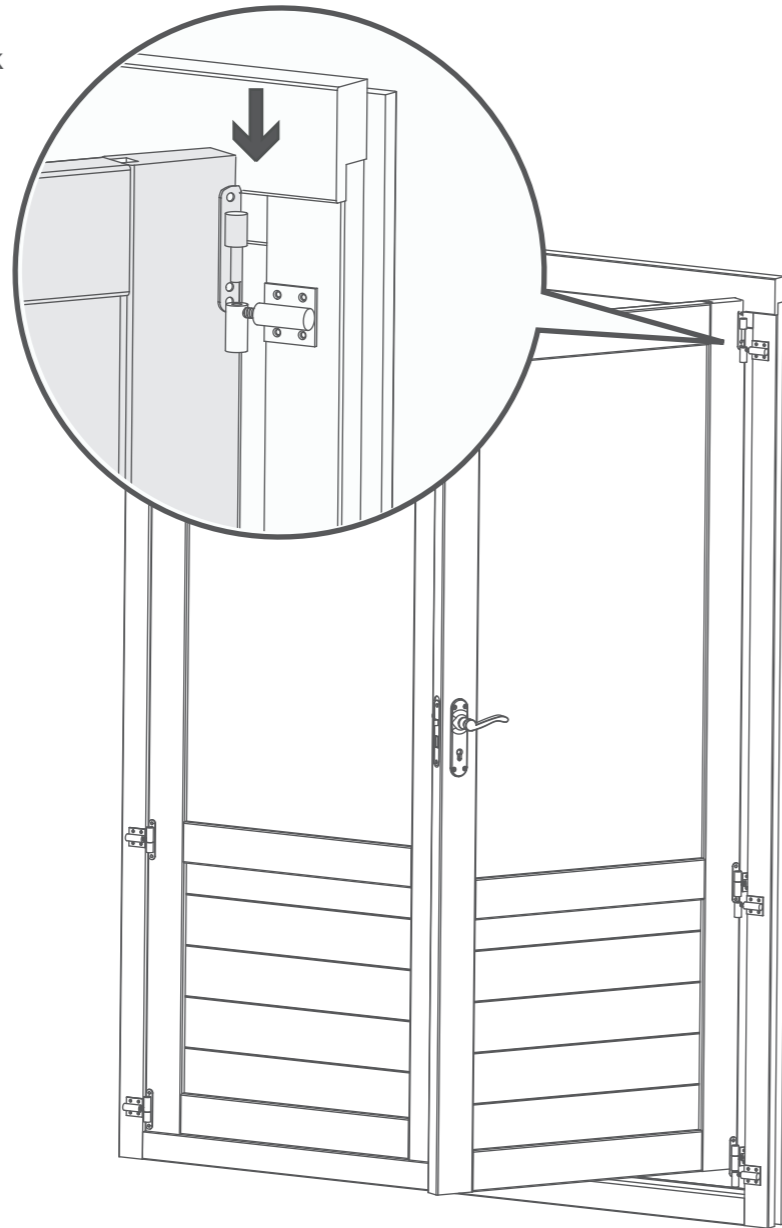

Step 23

**Parts Needed - No. 18 QTY 1
No. 19 QTY 1
No. 20 QTY 1**

a Fit the Mortice lock (**No. 19**) into the recess in the master door (**No. 9**) and secure using the screws provided. Attach the Key plate (**No. 20**) to the secondary door (**No. 10**) with 4x30mm screws.

b Fit the door handles (**No. 18**) and connect with the metalbar to the mortice lock using 8x30mm screws. Ensure the lock mechanism closes correctly. If not, remove the lock and turn the catch around by pulling the spring loaded latch and turning it 180 degrees.

***Please note:** This image is for illustrative purposes and may differ from your choice in product (**regarding ironmongery**). Nevertheless the process of fixing is the same.

Once components have been fitted, try closing doors to ensure the doors can be closed and the lock works.

If your doors do need adjusting please look at step 7.

12x30mm Screws



IMPORTANT : Pre-drill before fixing screws.

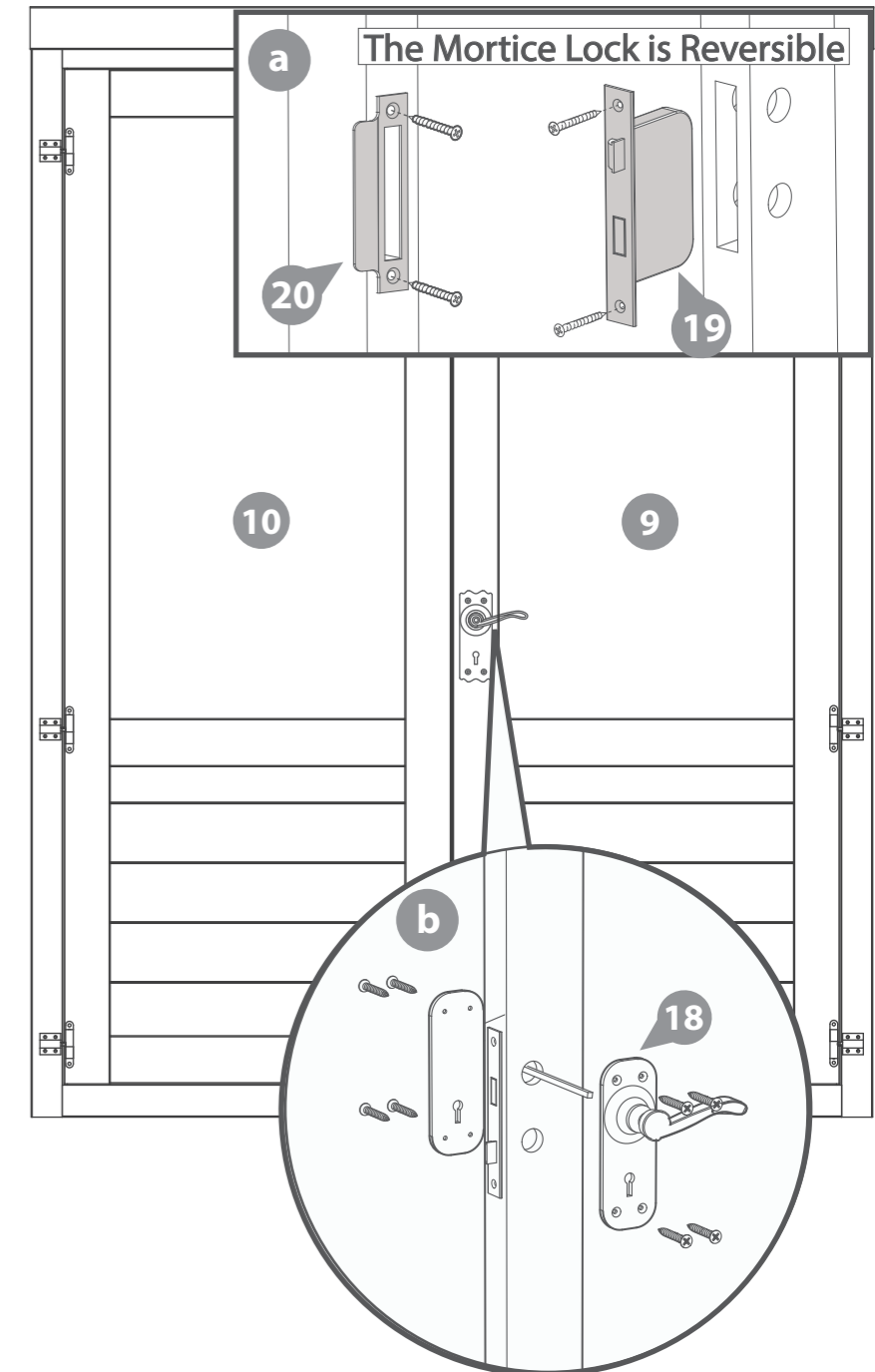

Step 24

**Parts Needed - No. 15 QTY 1
No. 21 QTY 2**

Attach the Door Strip (**No. 15**) to the back of the secondary door using 4x40mm screws as shown.

a Once fixed, place the Tower Bolts (**No. 21**) roughly into position at the top and bottom of the door strip. With a pencil mark the around the bolt.

b After marking the bolt onto the frame, drill a hole for the barrel bolt to locate into.

c Following the hole being drilled, place the tower bolts into position and secure using the screws provided.

4x40mm Screws



IMPORTANT : Pre-drill before fixing screws.

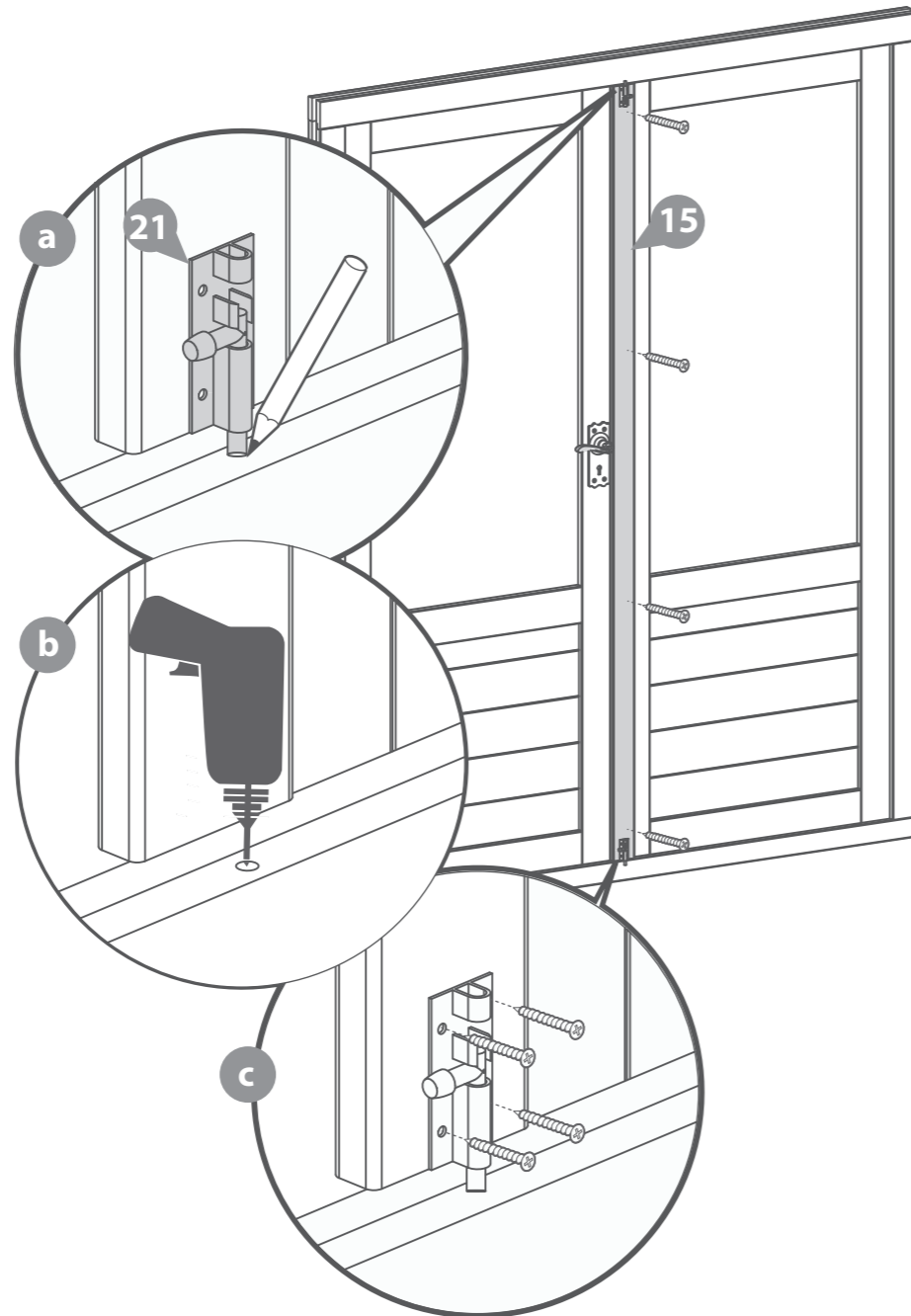

Step 25

Parts needed - No. 34 QTY 35

Place the first floor board (**No. 34**) inside the building flush to the log board on one side. Continue adding the floor boards (*internally*) making sure to interlock each individual board.

***Do NOT secure the boards until the last board has been measured and cut.**

Following the same method as before measure the gap between the bottom of the tongue (**on the last board placed**) and the log board.

Using a straight edge mark out the measurement onto the last floor board (**No. 34**) and cut along the length removing the excess.

****Please note:** Mark the final board 2mm under the measurement; This will allow the timber to expand and contract correctly.

Once all the floor boards are in position secure each board into position using 8x40mm screws.

You have been issued with 35 floor boards, but in reality you may only need to use 34

*****Please Note:** Ensure to screw through each of the floor boards into the floor bearers.

280x40mm Screws

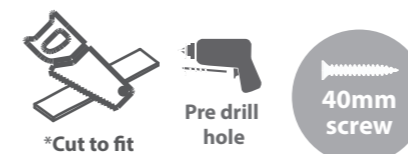

IMPORTANT : Pre-drill before fixing screws.

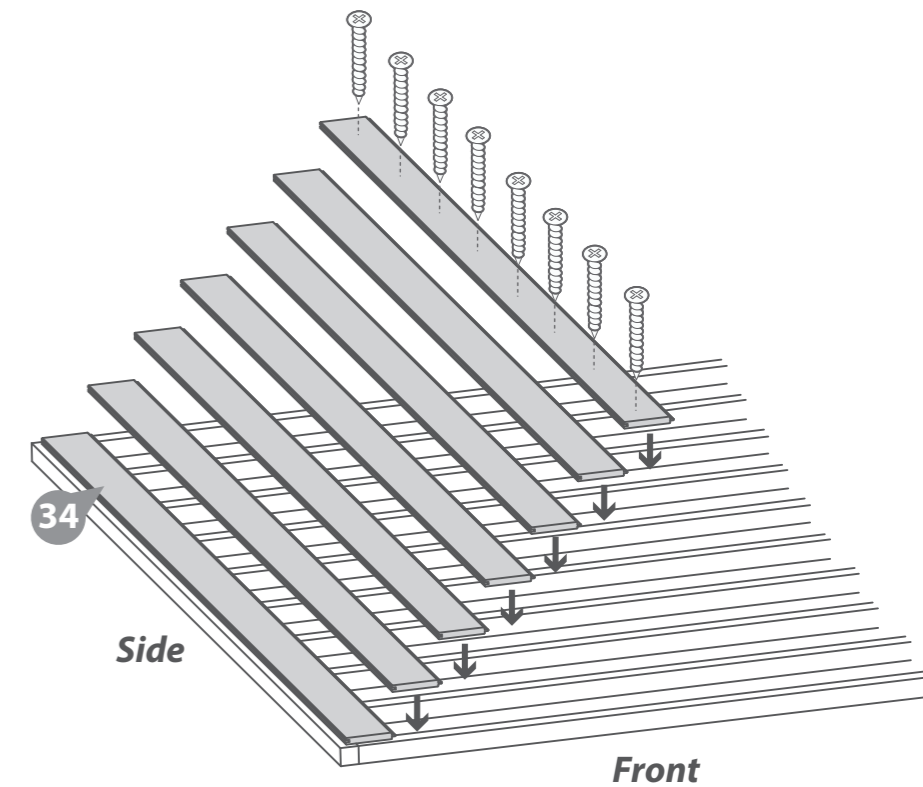

Side

Front

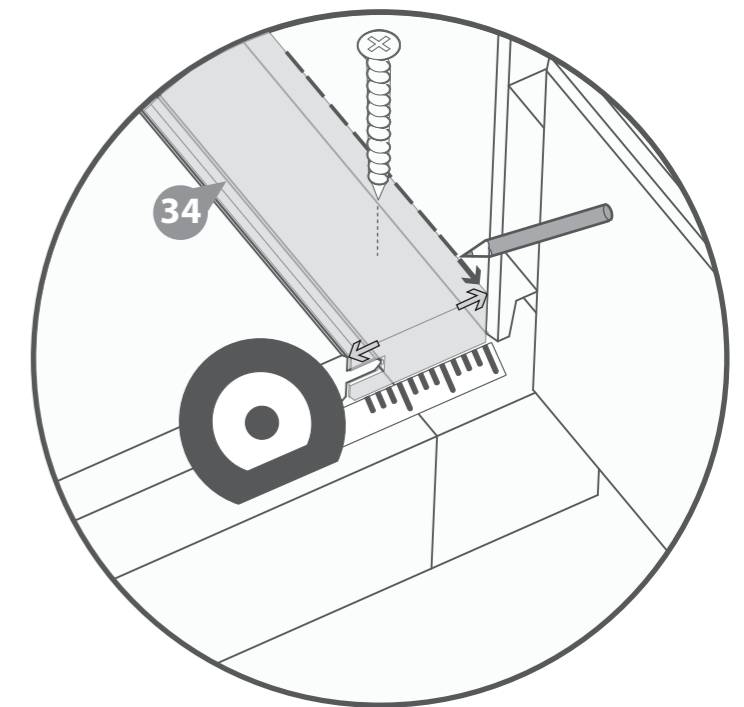

Step 26
Parts needed - No. 42 QTY 7

Inside the building place the closure trim (No. 42) against the boarding and align with the roof as shown in the illustration.

***Measure and cut the closure trims to fit the internal space.**

Once in position fix each trim into place by pre drilling a pilot hole and using 6x30mm screws per trim, equally spacing them along the face of the board.

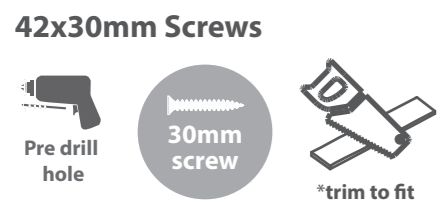

IMPORTANT : Pre-drill before fixing screws.

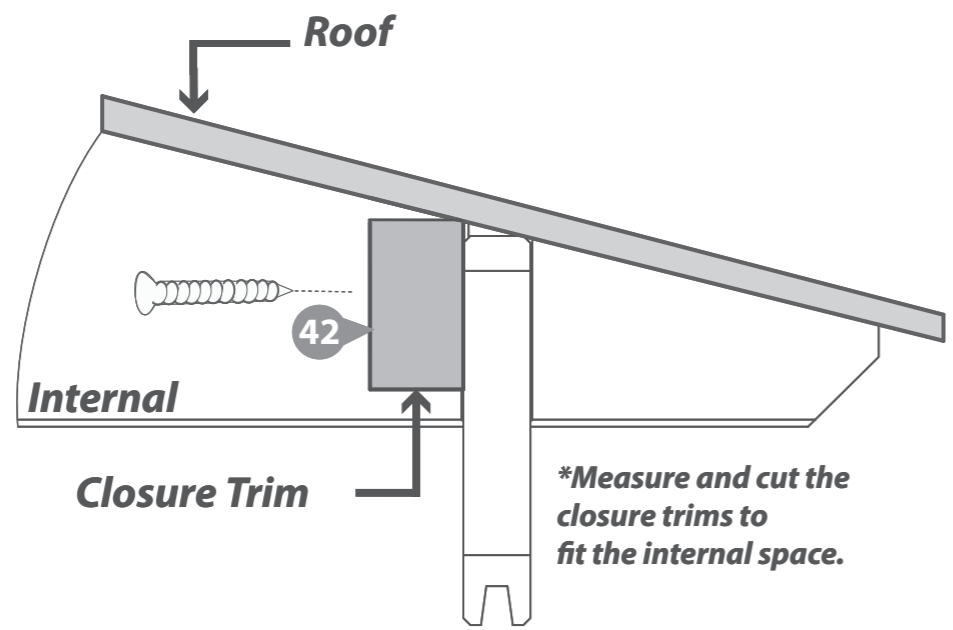

Step 28
Parts needed - No. 43

Cut the felt into four strips and lay onto the roof in the order shown in the illustration.

***Ensure there is approximately 50mm of overhanging felt each side.**

Once the felt is laid out fix to the roof using felt tacks at 100mm intervals.

***Felt size: 4104 mm**

300x Felt Tacks

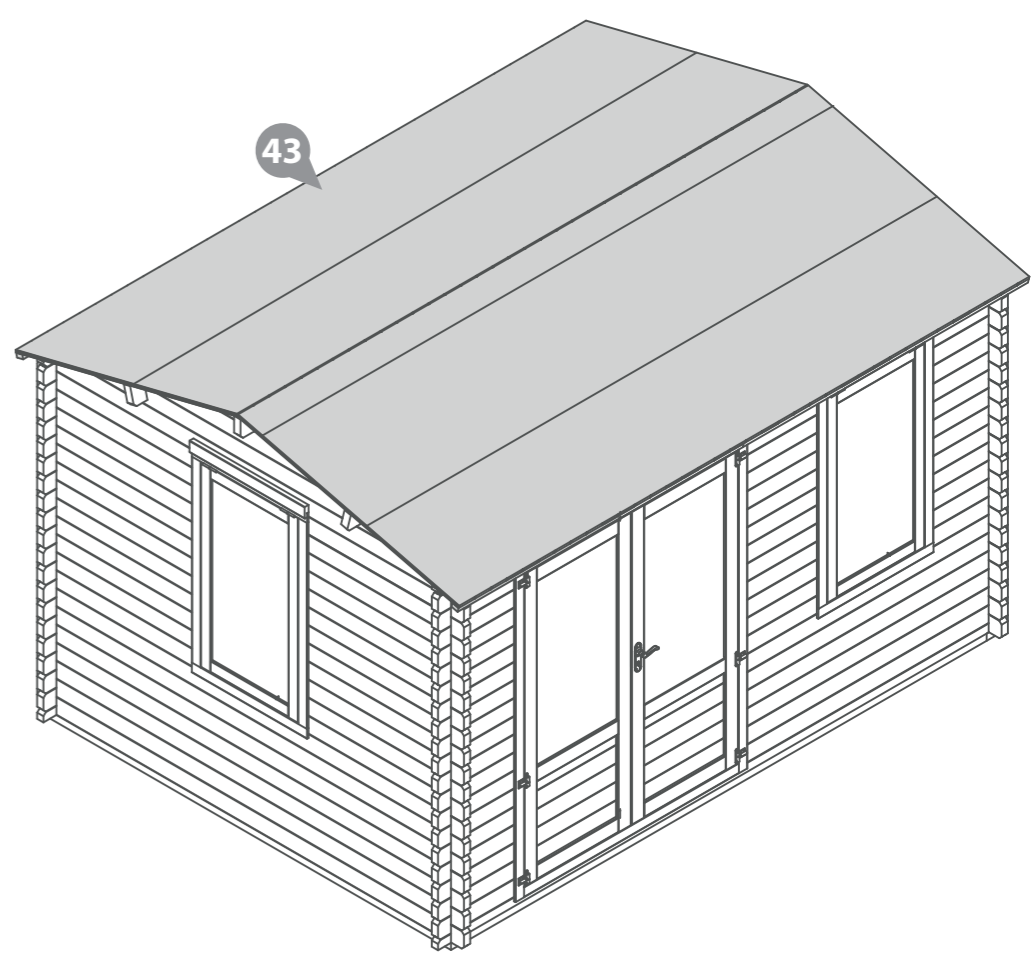

Step 27
Parts needed - No. 42 QTY 6

Once the floor has been laid arrange the closure trim (No. 42) around the outside edge of floor (**internally**), measure and cut down accordingly to best match the internal space.

Secure each trim section into place using 6x30mm spaced equally along the board as shown in the illustration.

***Do NOT fix the closure trim to the floor boards.**

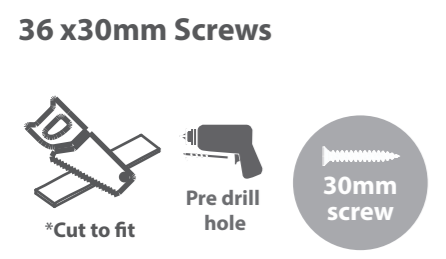

IMPORTANT : Pre-drill before fixing screws.

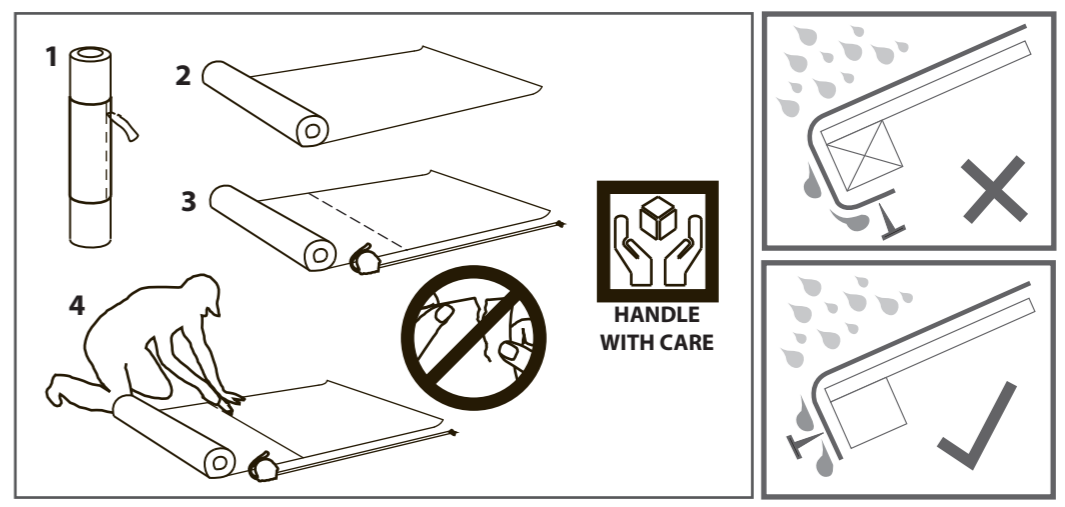
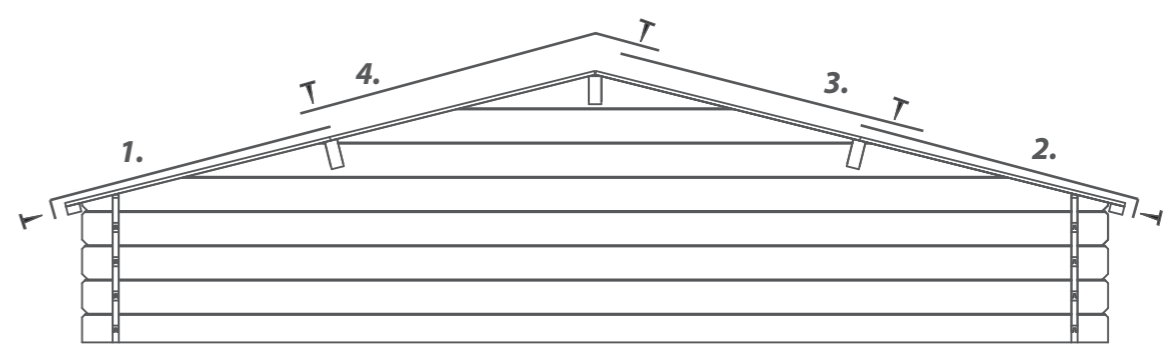
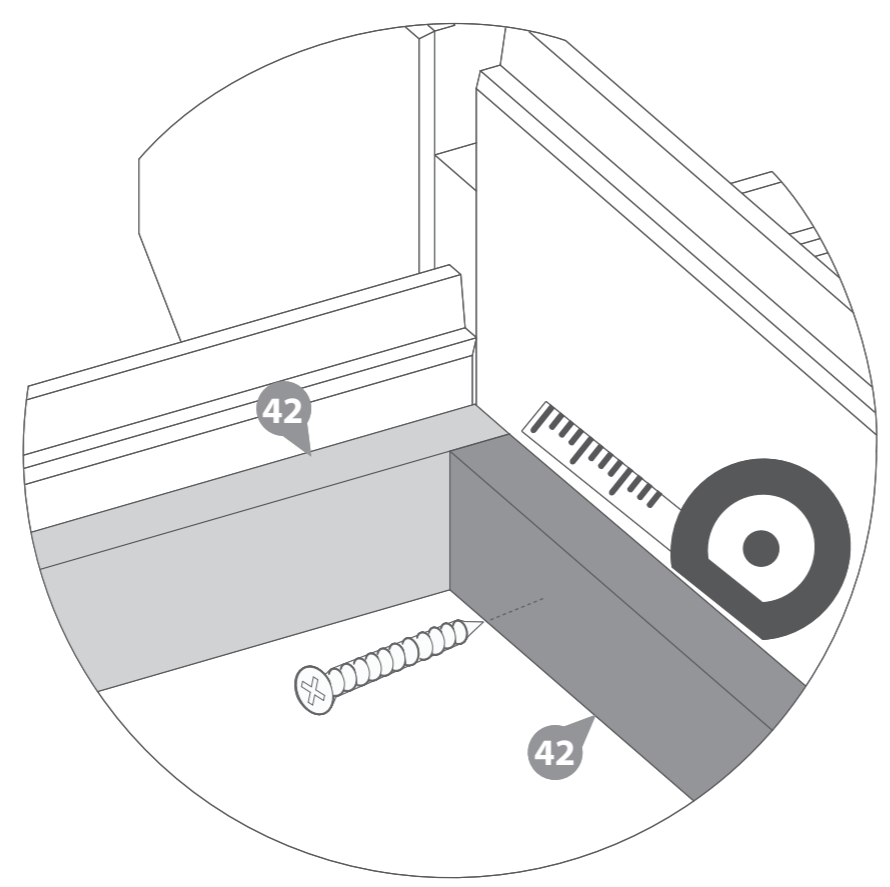

Step 29

Parts Needed: No. 6 QTY 2
No. 16 QTY 1

Attach the Rain Guards (**No.6**) to the window frame, fixing in place onto the framing above each window using 3x70mm screws per guard.

Attach the Rain Guard (**No.16**) to the door frame, fixing in place onto the framing above the Door using 4x70mm screws.

10x70mm Screws.



IMPORTANT : Pre-drill before fixing screws.

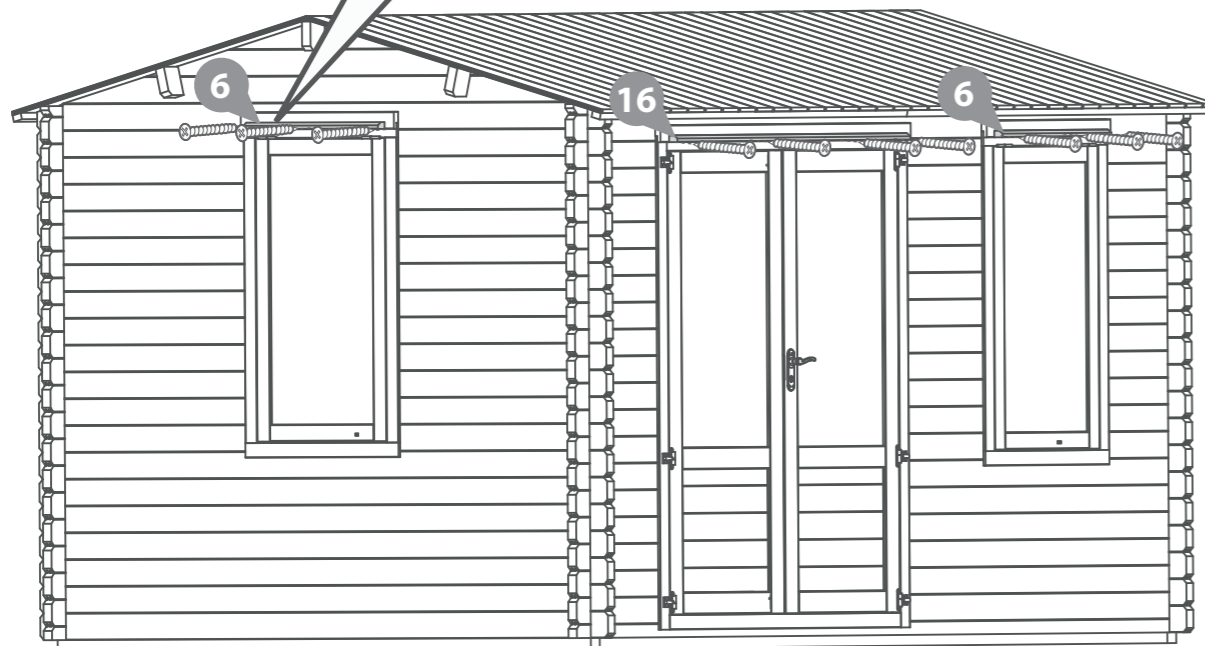
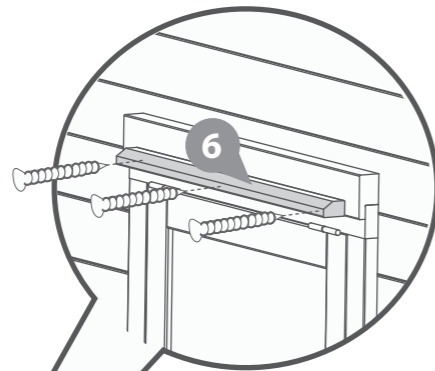

Step 30

Parts needed - No. 39 QTY 4
No. 40 QTY 4

Align the fascia's (**No. 39 & 40**) with the roof and fix into place using 3x40mm screws per fascia, making sure to screw through the fascia into the roof purlins and eaves frame.

***Ensure the angled cuts meet at the top of the apex.**

24x40mm Screws



IMPORTANT : Pre-drill before fixing screws.

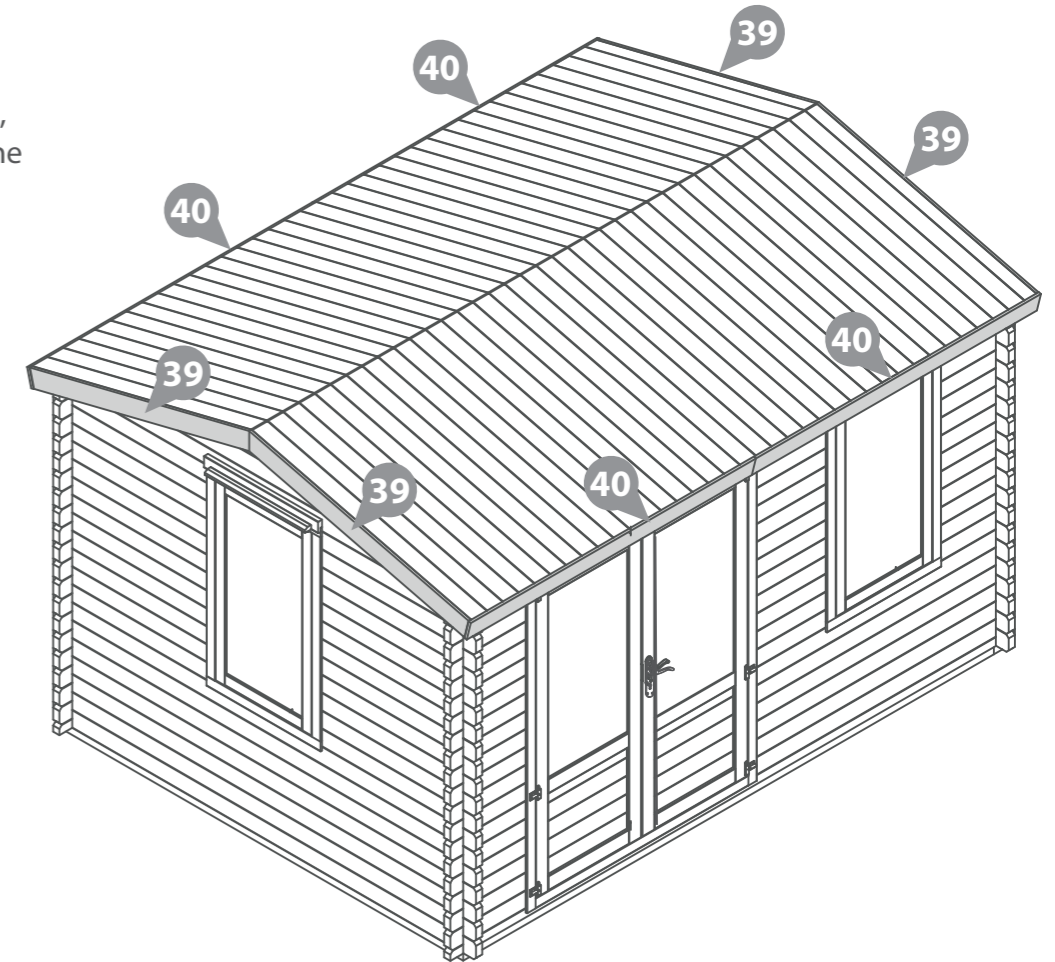

Step 31

Parts needed - No. 41 QTY 8

Arrange the storm braces (**No. 41**) around the building (**internally**). Place 2 Storm Braces per side, fixing into place using 2x90mm bolts per brace, making sure the washer & nut are tightened from the outside of the building.

***Ensure the storm braces are secured at the highest point possible on each side.**

The storm braces will need to be altered during the building's life as the moisture content within the log boards changes. The boards will expand during periods of high moisture (winter) and shrink during periods of low moisture (summer)

****Storm braces will help your building expand and contract properly.**

*****Important: Ensure each bolt is tightened using a washer so as not to damage the log boards.**

16x90mm Bolt Sets



IMPORTANT : Pre-drill before fixing screws.

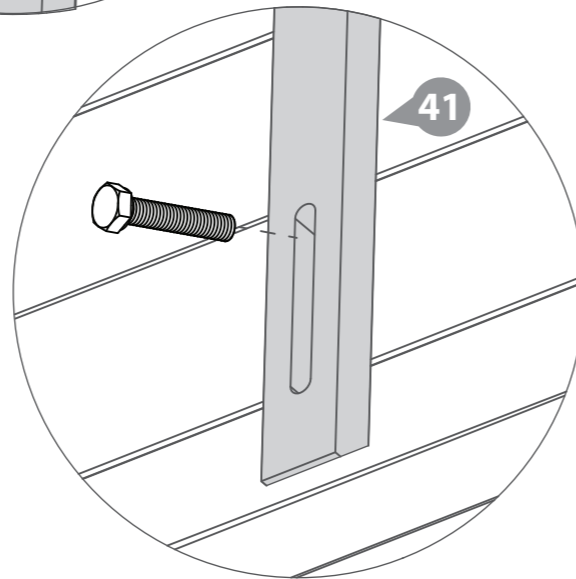
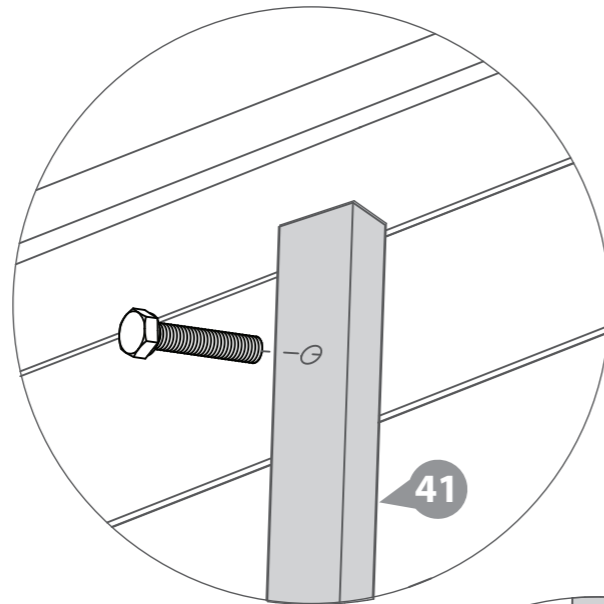

It is ESSENTIAL that you apply wood treatment immediately after the building has been assembled.