

0628CSNE0303HGDD2SW-V2
 28MM 3M X 3M CORNER LOG CABIN.

BEFORE YOU START PLEASE READ INSTRUCTIONS CAREFULLY

- Check the pack and make sure you have all the items listed in the parts list provided.
- When you are ready to start, make sure you have the right tools at hand (not supplied - see the equipment list on next page).
- Ensure you have enough time to build the product to ensure the building is water tight.

LOCATION FOR YOUR GARDEN BUILDING

A minimum of 600mm should be left around the perimeter of your garden building to allow access for maintenance, annual treatment and to allow air flow around the building.

Where possible you should avoid placing your garden building underneath large trees to prevent the tree causing damage to the building.

TIMBER

As with all natural materials, timber can be affected during various weather conditions. For the duration of heavy or extended periods of rain, swelling of the wood panels may occur. Warping of the wood may also occur during excessive dry spells due to an interior moisture loss. Unfortunately, these processes cannot be avoided but can be helped. It is suggested that the outdoor building is sprayed with water during extended periods of warm sunshine and sheltered as much as possible during rain or snow.

Once your garden building has been installed it will need to be treated within 14 days (weather permitting) and annually to prevent the timber from deteriorating and to waterproof it. This is required to maintain the anti-rot guarantee.

Log Cabins/Insulated Garden Rooms - Are supplied untreated and require a preservative and waterproofing treatment.

BUILDING A BASE

When thinking about where the building and where the base is going to be constructed: Ensure that there will be access to all sides for maintenance work and annual treatment.

Ensure the base is level and is built on firm ground, to prevent movement. Refer to the contents page for the base dimensions. The base should be slightly smaller than the external measurement of the building, i.e. The cladding should overlap the base, creating a run off for water. It is also recommended that the floor be at least 25mm above the surrounding ground level to avoid flooding.

TYPES OF BASE

- Concrete 75mm laid on top of 75mm hard-core.
- Slabs laid on 50mm of sharp sand.
- Wooden base - Levelled / on posts / ground screws.

Whilst all products manufactured are made to the highest standards of safety and in the case of children's products independently tested to EN71 level, we cannot accept responsibility for your safety whilst erecting or using this product.



x2 All building's should be erected by two adults



Winter = High Moisture = Expansion
 Summer = Low Moisture = Contraction



2mm Drill bit

For ease of assembly, you **MUST** pilot drill all screw holes and ensure all screw heads are countersunk.



CAUTION
 Every effort has been made during the manufacturing process to eliminate the prospect of splinters on rough surfaces of the timber. You are strongly advised to wear gloves when working with or handling rough sawn timber.



For ease of assembly use a rubber mallet to fit the log boards. Do NOT use a heavy hammer.



Ensure to measure and check before cutting boards.

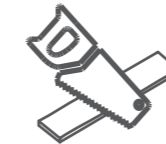

It is advisable to use a hand saw when cutting roof and floor boards.



To ensure log boards are even, use a spirit level to check each layer has been installed correctly.

Screws & Nails



Bolts



To identify the fixings required for each step use a measuring tape.

**REGISTER FOR YOUR
 ANTI-ROT
 GUARANTEE TODAY**

PLEASE SCAN HERE:

In all instances for assistance with your product, please contact us via our customer portal: <https://www.mgplistics.co.uk/>.

Mercia Garden Products Limited,
 Sutton On Trent,
 Newark,
 Nottinghamshire,
 NG23 6QN



TO DO LIST

- Find a suitable location to build *(see front cover for further information)*.
- Build a base *(see front cover for further information)*.
- Check the base is flat, level, clear of debris and has 60cm clearance on all sides.
- Check you have the required equipment / tools.
- Check you have all the product items listed *(if you have missing or damaged parts please scan the QR code below to visit our online customer portal)*
- Install the product as per the step by step instructions within this pack.
- Prepare the product ready for treatment (This may include sanding).
- Apply a preserving and a waterproofing treatment within 14 days *(weather permitting)* of installation.
- Register for your anti rot guarantee *(scan the QR below)*.
- Tidy the build area and dispose of any remaining parts responsibly.
- Maintain your building *(see the manufacturers recommendations at the back of this pack)*.

EQUIPMENT LIST

- Hammer
- Mallet
- Flat Head Screwdriver
- Drill
- Drill Bit Set
- Phillips and Slotted Bit Sets
- Tape Measure
- Hand Saw
- Spirit Level
- Ladders/Steps
- Stanley Knife/Cutting Tool
- Sand Paper
- Gloves
- Silicone (For Windows Only)
- Wood Filler (Optional)
- Timber Preservative Treatment
- Timber Water Proofing Treatment
- Treatment Mixing Stick
- Paint Brush/Sprayer/Roller

NEED EXTRA SUPPORT

If you are unsure that your base preparation will be suitable, please contact us via our customer portal to discuss this further.

Alternatively, you can visit our website or MGP Logistics Online Portal for some further shededucation.

Website:

<https://www.merciagardenproducts.co.uk/sheducation>

MGP Logistics Online Portal:

<https://www.mgplogistics.co.uk/>

Here you will find plenty of useful information that'll help with most pre-installation and maintenance queries.

PLEASE SCAN HERE:



ANY QUESTIONS?

Scan the QR code to contact us via our customer portal.

NOTES



Overall Dimensions: Width = 4437mm
Depth = 3316mm
Height = 2907mm

Base Dimensions: Width = 3971mm
Depth = 2988mm

PLEASE SCAN HERE:

ANY QUESTIONS?
Scan the QR code to contact us via our customer portal.

Tip: Labelling your parts, using a pencil and masking tape, may help you to identify them easier when you need them.



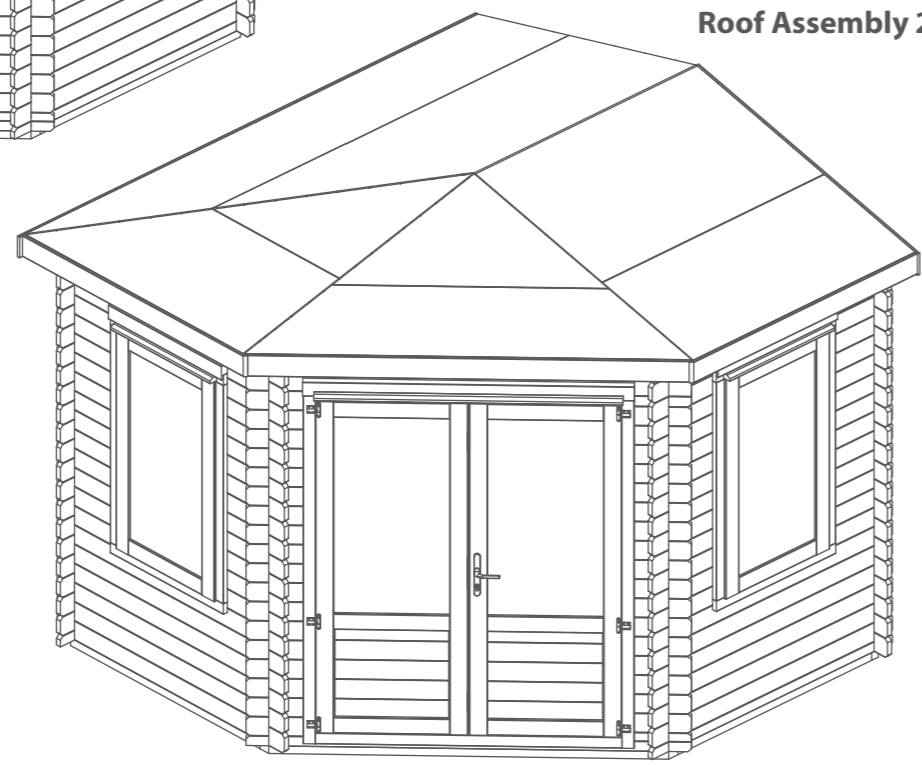
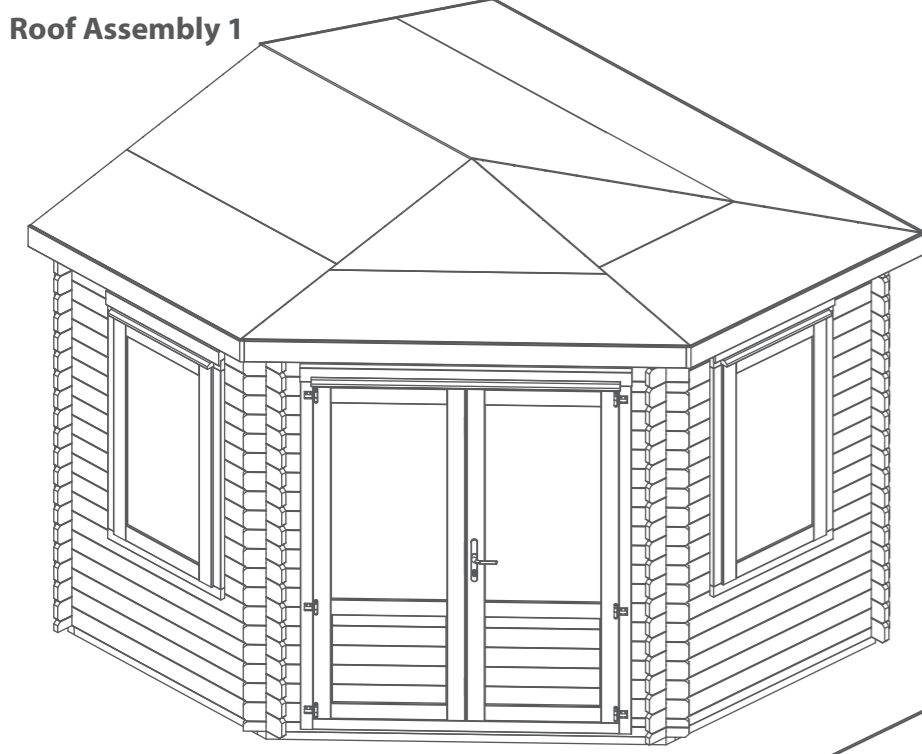

NO.1 STARTER BOARD









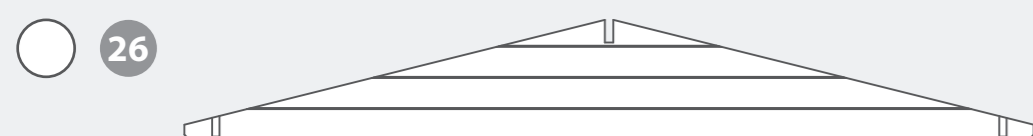

Log Boards Contents:

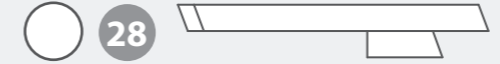
- 1 **Starter Board - 28x66x2191mm QTY 1**
LB28RT66-AGRL-2191mm (1x45 deg cut top, 1x45 deg cut bottom)
- 2 **Starter Board - 28x66x3000mm QTY 1**
LB28RT66-A-3000mm
- 3 **Starter Board - 28x66x1625mm QTY 1**
LB28RT66-AGL-1625mm (1x45 deg cut left)
- 4 **Log Board - 28x120x3000mm QTY 39**
LB28-A-3000mm
- 5 **Log Board - 28x120x3000mm QTY 1**
LB28-A-3000mm (Vent cut out)
- 6 **Log Board - 28x60x311mm QTY 1**
LB28-BH60GR-311mm (1x45 deg cut right, 60mm height board)
- 7 **Log Board - 28x120x1625mm QTY 7**
LB28-AGR-1625mm (1x45 deg cut right)
- 8 **Log Board - 28x120x1625mm QTY 6**
LB28-AGL-1625mm (1x45 deg cut left)
- 9 **Log Board - 28x120x311mm QTY 18**
LB28-BGL-311mm (1x45 deg cut left)
- 10 **Log Board - 28x120x311mm QTY 17**
LB28-BGR-311mm (1x45 deg cut right)
- 11 **Log Board - 28x120x439mm QTY 24**
LB28-B-439mm
- 12 **Log Board - 28x120x439mm QTY 12**
LB28-BGR-439mm (1x45 deg cut right)
- 13 **Log Board - 28x120x439mm QTY 12**
LB28-BGL-439mm (1x45 deg cut left)





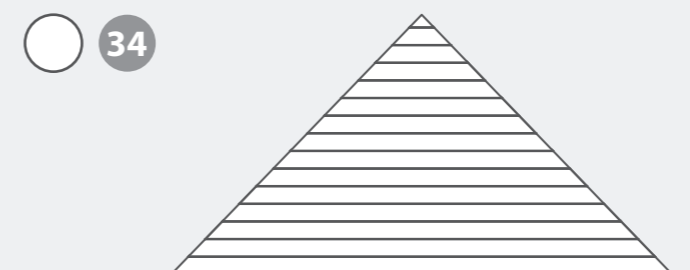
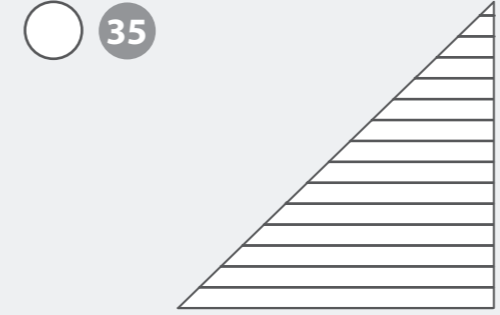







Log Boards Contents:

- 
14 Log Board - 28x70x311mm QTY 1
LB28-BH70GR-311mm (1x45 deg cut right bottom notch, 70mm height board)
- 
15 Log Board - 28x120x1625mm QTY 1
LB28-JDR-1625mm (1x45 deg cut right, window notch)
- 
16 Log Board - 28x120x1625mm QTY 1
LB28-JDL-1625mm (1x45 deg cut left 50mm bottom notch, window notch)
- 
17 Log Board - 28x120x2191mm QTY 1
LB28-JD-2191mm (1x45 deg cut left, 1x45 deg cut right top notch, door notch)
- 
18 Log Board - 28x120x1625mm QTY 1
LB28-J-1625mm (1x45 deg cut left, 50mm bottom notch)
- 
19 Log Board - 28x120x2191mm QTY 1
LB28-J-2191mm (1x45 deg cut left, 1x45 deg cut right top notch. Vent cut out)
- 
20 Finisher Board - 28x64x1625mm QTY 1
LB28-AH64GR-1625mm (64mm high board, 1x45 deg cut right)
- 
21 Finisher Board - 28x64x3000mm QTY 1
LB28-AH64-3000mm (64mm high board)
- 
22 Finisher Board - 28x80x1945mm QTY 1
LB28RG80-J-1945mm (2x45 deg cuts, 2 x cut out notches)
- 
23 Finisher Board - 28x80x677mm QTY 1
LB28RG80-CGL-677mm (2x45 deg cut right)
- 
24 Finisher Board - 28x80x677mm QTY 1
LB28RG80-CGR-677mm (2x45 deg cut left)
- 
25 Finisher Board - 28x80x638mm QTY 6
LB28RG80-C-638mm
- 
26 Gable QTY 1
AI-0628LOGC3-G-V1

Roof Contents:





- 
27 Left Roof Truss - 40x140x922mm QTY 1
AI-06LOGC3X3-LRT-V1
 - 
28 Right Roof Truss - 40x140x922mm QTY 1
AI-06LOGC3X3-RRT-V1
 - 
29 Roof Truss A- 40x140x1604mm QTY 5
AI-06LOGC3RTA-V1 (2x76 deg parallel cuts)
 - 
30 Roof Truss B - 40x140x2225mm QTY 1
AI-06LOGC3RTB-V1 (2x45 deg cuts each end)
 - 
31 Roof Truss C- 40x140x1604mm QTY 1
AI-06LOGC3RTC-V1 (2x76 deg parallel cuts right)
 - 
32 Roof Truss D- 40x140x1604mm QTY 1
AI-06LOGC3RTD-V1 (2x76 deg parallel cuts left)
 - 
33 Roof Purlin - 45x120x1523mm QTY 1
F45120-B-1523mm
 - 
34 Roof Board Pack A QTY 1
AI-06LOGC3X3RBP1-V2
 - 
35 Roof Board Pack B QTY 2
AI-06LOGC3X3RBP2-V2
 - 
36 Roof Board Pack C QTY 2
AI-06LOGC3X3RBP3-V2
- *If you are constructing a 5x3 cabin you will not need this part - see 5x3 instructions for correct part*
- *HINT: keep the individual roof board packs together to prevent mixing them up.**

Fixing Kit Contents:

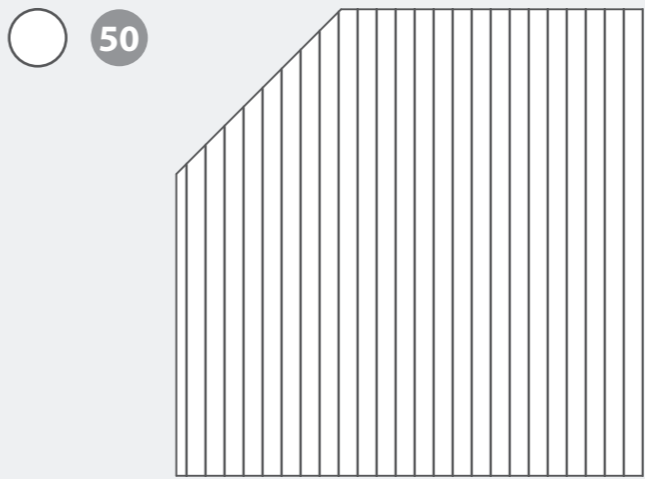
-  **37**  **Bearer - 44x44x2808mm QTY 1**
F4444-2808mm-PT
-  **38**  **Bearer - 44x44x2720mm QTY 6**
F4444-2720mm-PT
-  **39**  **Bearer - 44x44x2492mm QTY 1**
F4444-G-2492mm-PT (1x45 deg cut)
-  **40**  **Bearer - 44x44x2222mm QTY 1**
F4444-G-2222mm-PT (1x45 deg cut)
-  **41**  **Bearer - 44x44x1951mm QTY 1**
F4444-G-1951mm-PT (1x45 deg cut)
-  **42**  **Bearer - 44x44x1680mm QTY 1**
F4444-G-1680mm-PT (1x45 deg cut)
-  **43**  **Bearer - 44x44x1399mm QTY 1**
F4444-G-1399mm-PT (1x45 deg cut)
-  **44**  **Bearer - 44x44x1356mm QTY 1**
F4444-G-1356mm-PT (1x45 deg cut)
-  **45**  **Bearer - 44x44x2055mm QTY 1**
F4444-G-2055mm-PT (2x45 deg cuts)
-  **46**  **Fascia - 16x120x3100mm QTY 1***
SR16120-3100mm
-  **47**  **Fascia - 16x120x2225mm QTY 1***
SR16120-2225mm
-  **48**  **Fascia - 16x120x2000mm QTY 2***
SR16120-2000mm
-  **49**  **Fascia - 16x120x1658mm QTY 2***
S16120-G-1658mm (2 x angled cuts)

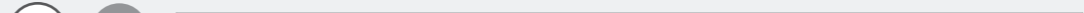
Fixing Kit Contents:

-  **50** **Floor Board Pack QTY 1***
AI-0628CSNE0303HGDD2SW-FBP-V1

***HINT: keep the floor board pack together to prevent mixing it up.**
-  **51** **Closure Trim - 16x28x2400mm (approx length) QTY 10***
S1628-2400mm
-  **52** **Storm Brace - 44x27x2000mm QTY 8**
F2744-2000mm
-  **53** **Plastic Vent QTY 4**
PI-07-0237
-  **54** **Felt**
-  **55** **2mm Spacer QTY 5**
PI-07-0208 (20x100x2mm)

***This part will be longer than needed and requires cutting to size when used. This will be explained when required within the instruction step.**

Note: one piece may be required to be cut into multiple different sizes. Do not dispose of off-cuts until the building is fully constructed as they may be needed in another step.

Door Contents:

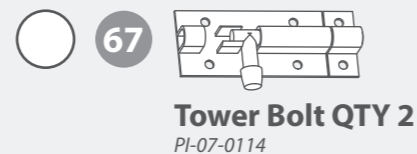
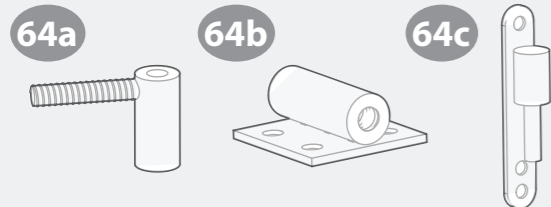
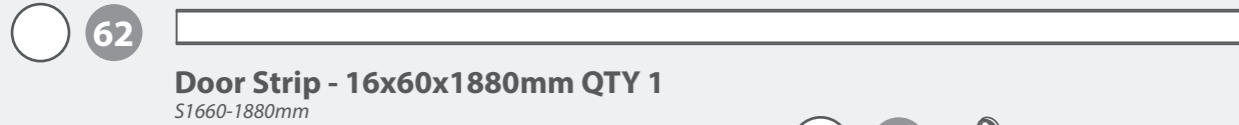
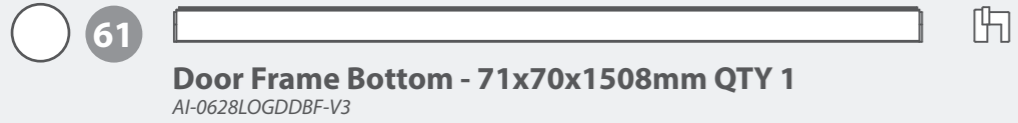
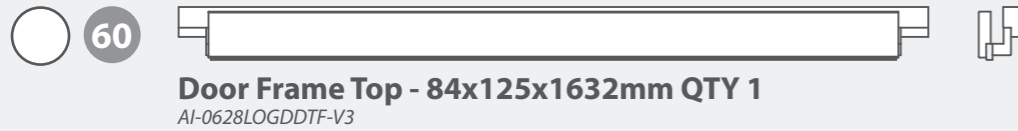
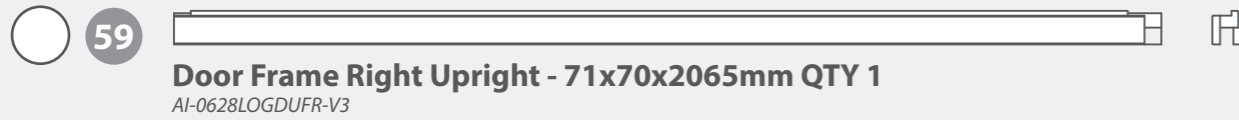
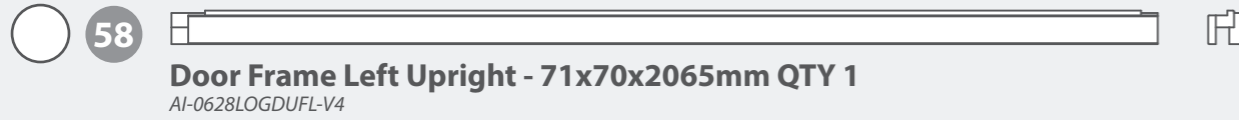
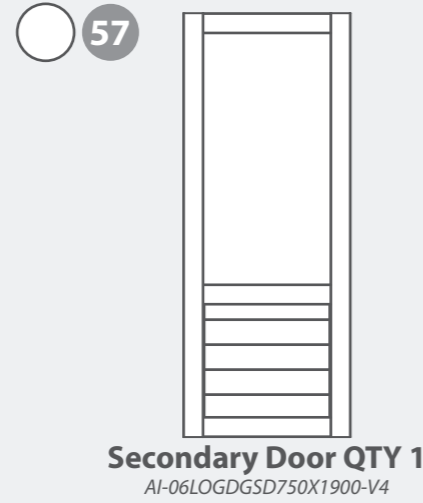
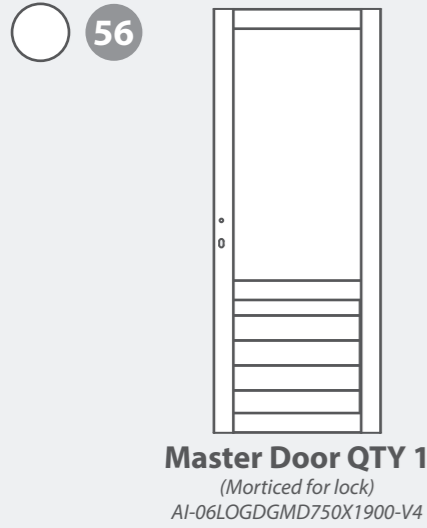

Window Contents:

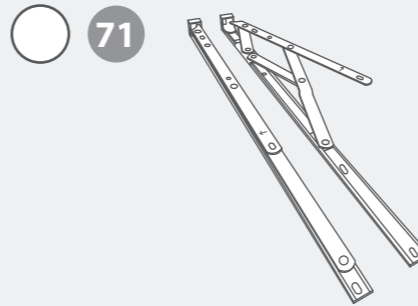
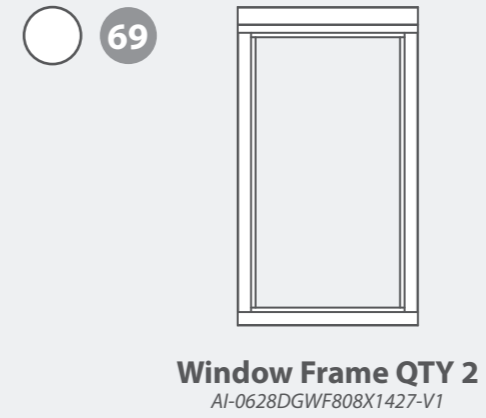
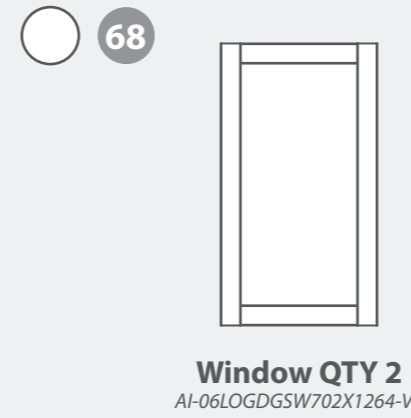

Screw Pack.

There may be extra screws present in the pack.



PLEASE SCAN HERE:



Missing parts?

Scan the QR code to visit our customer portal where you can quickly raise any missing or damaged parts and get a replacement sent out ASAP.



**TO CONSTRUCT A 5M X 3M LOG CABIN,
PLEASE REFER TO THE 5X3
INSTRUCTIONS.**

Pre-assembly

***Please note:**

Each board interlocks at either end in a staggered pattern.

Before securing ensure that the boards are fitted properly in their respective tongue's and groove's.

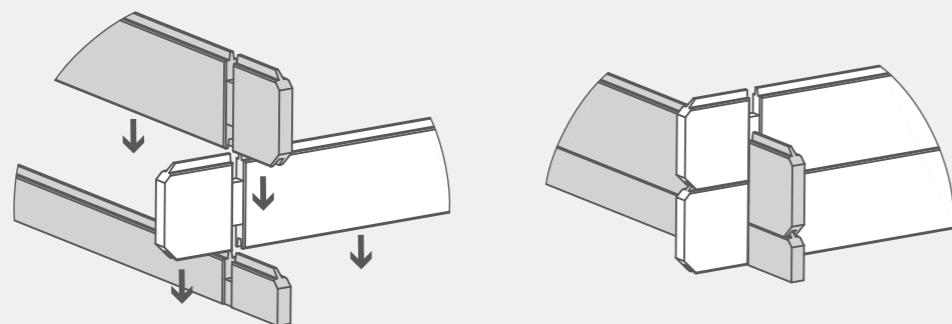

The following steps show how to construct a **3m x 3m corner log cabin**.
To construct a **5m x 3m corner log cabin**, please refer to the 5m x 3m instructions.

- Step 1**
Parts Needed - No. 37 QTY 1
No. 38 QTY 1
No. 43 QTY 1
No. 44 QTY 1
No. 45 QTY 1

Lay the bearers (**No. 37, 38, 43, 44 & 45**) onto a firm and level base (*free from areas where standing water can collect*) ensuring the bearers are flat and level and the ends are flush, as shown.

Fix the bearers together using 2x70mm screws per corner.

Once secured, ensure the bearers are square by measuring from corner to corner, making sure the measurements are equal. If the bearers are not aligned equally, unscrew, adjust and re-align accordingly.

10x70mm Screws
Important: Pre-drill before fixing screws.

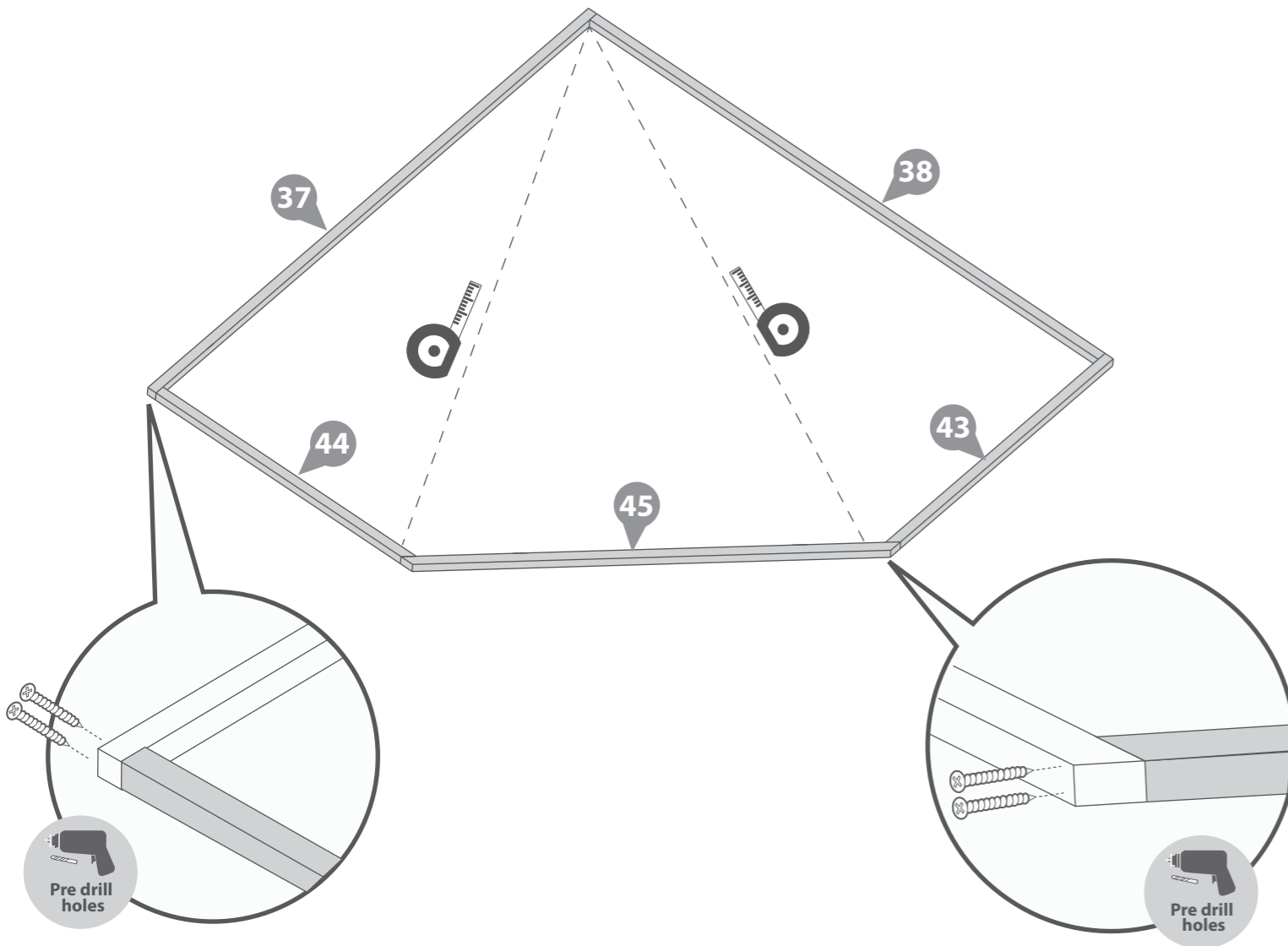
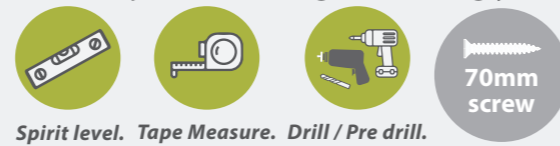

- Step 2**
Parts Needed - No. 38 QTY 5
No. 39 QTY 1
No. 40 QTY 1
No. 41 QTY 1
No. 42 QTY 1

Following the same method shown in the previous step, arrange the remaining bearers (**No. 38, 39, 40, 41 & 42**) inside the assembled frame, ensuring each piece is flush and level.

***Ensure there is an equal amount of space between each bearer.**

Secure each of the bearers in place by screwing through the outside framing into the framing behind using 2x70mm screws for each end of the bearer, as shown.

36x70mm Screws
Important: Pre-drill before fixing screws.

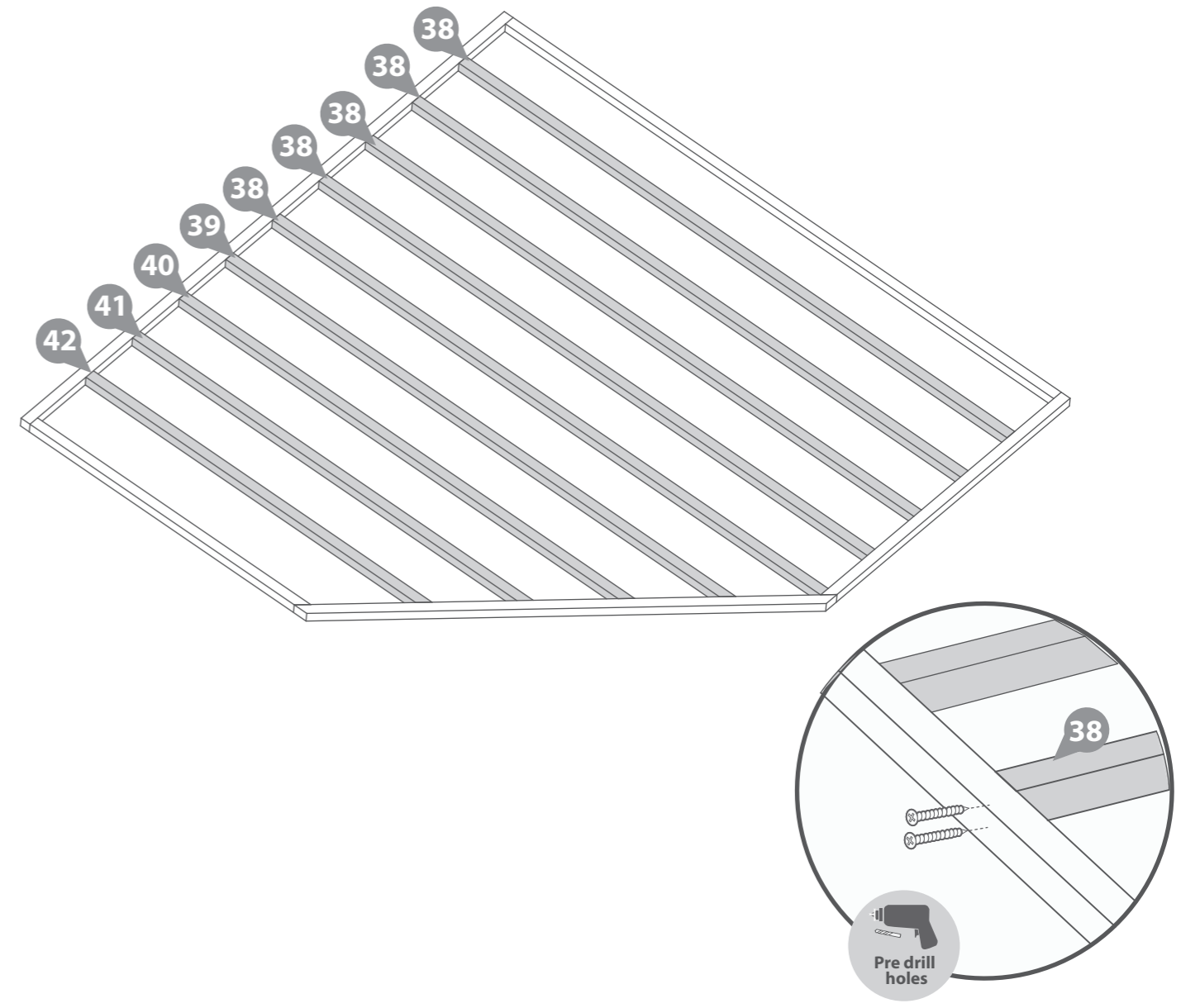
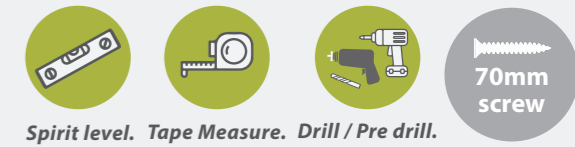

Step 3

- Parts Needed - No. 1 QTY 1**
No. 2 QTY 1
No. 3 QTY 1
No. 4 QTY 1
No. 7 QTY 1

Place the starter boards (**No. 1, 2 & 3**) on to the assembled bearers and lightly position the first two log boards (**No. 4 & 7**) into the notches as shown.

Ensure the boards sit square on the base using the same method used in Step 1. Measure corner to corner, making sure the measurements are equal.

Once the boards are square, lift up the log boards (**No. 4 & 7**) and fix the starter boards (**No. 1, 2 & 3**) in place by screwing through the notch into the bearer below, using 1x70mm screw per notch.

Note: Use a mallet and a scrap piece of wood to gently persuade the log boards into place.

5x70mm Screws
Important: Pre-drill before fixing screws.

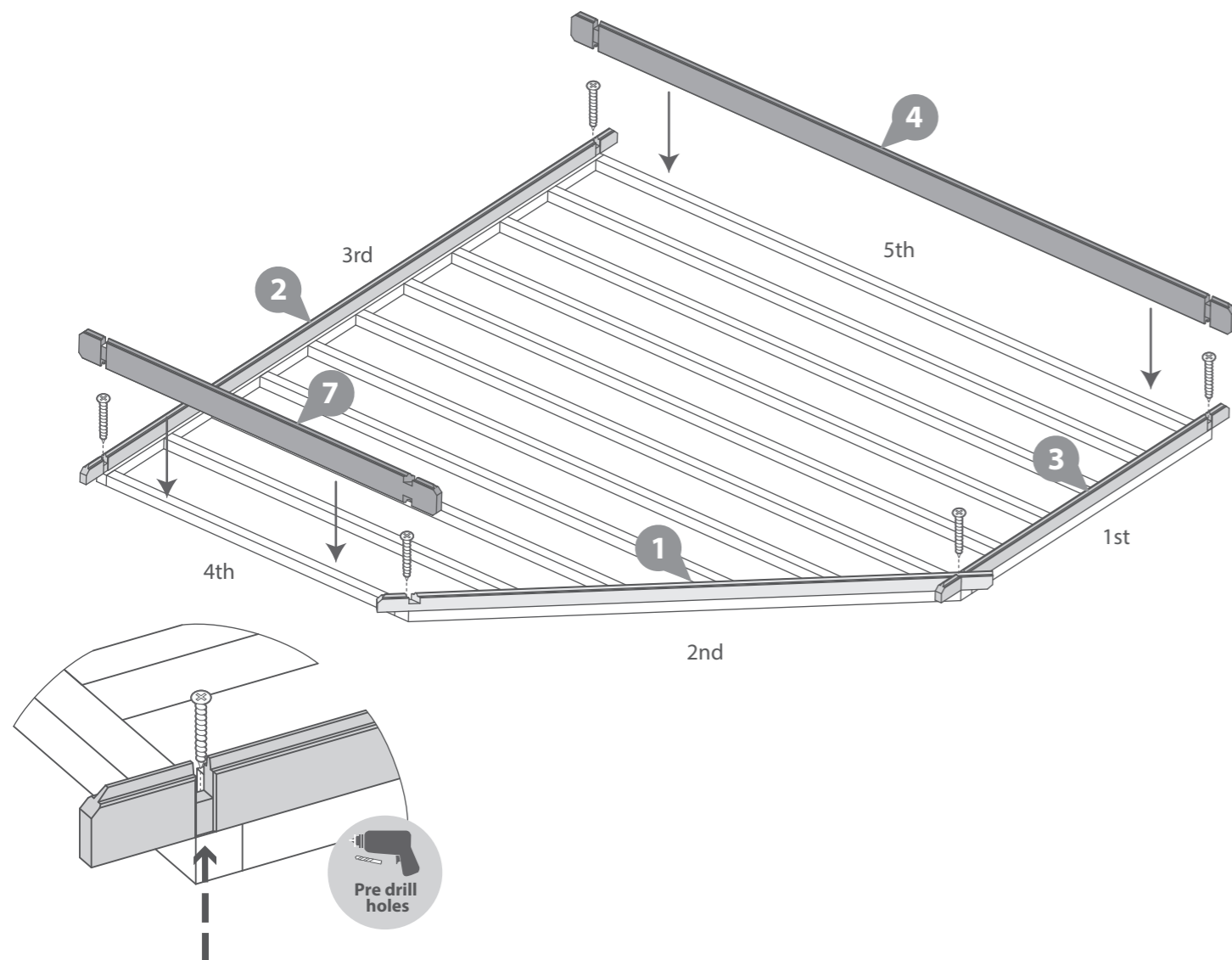

Step 4

- Parts Needed - No. 6 QTY 1**

Make the log cabin level by laying another board (**No. 6**) onto the right side of the cabin, as shown.

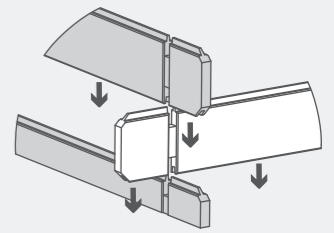

Secure the board in place by screwing through the notch using 1x70mm screw. Ensure to stagger the screw to avoid collision with the one below.

***Ensure that the boards are level and flush with each other as you lay each one.**

1x70mm Screws
Important: Pre-drill before fixing screws.

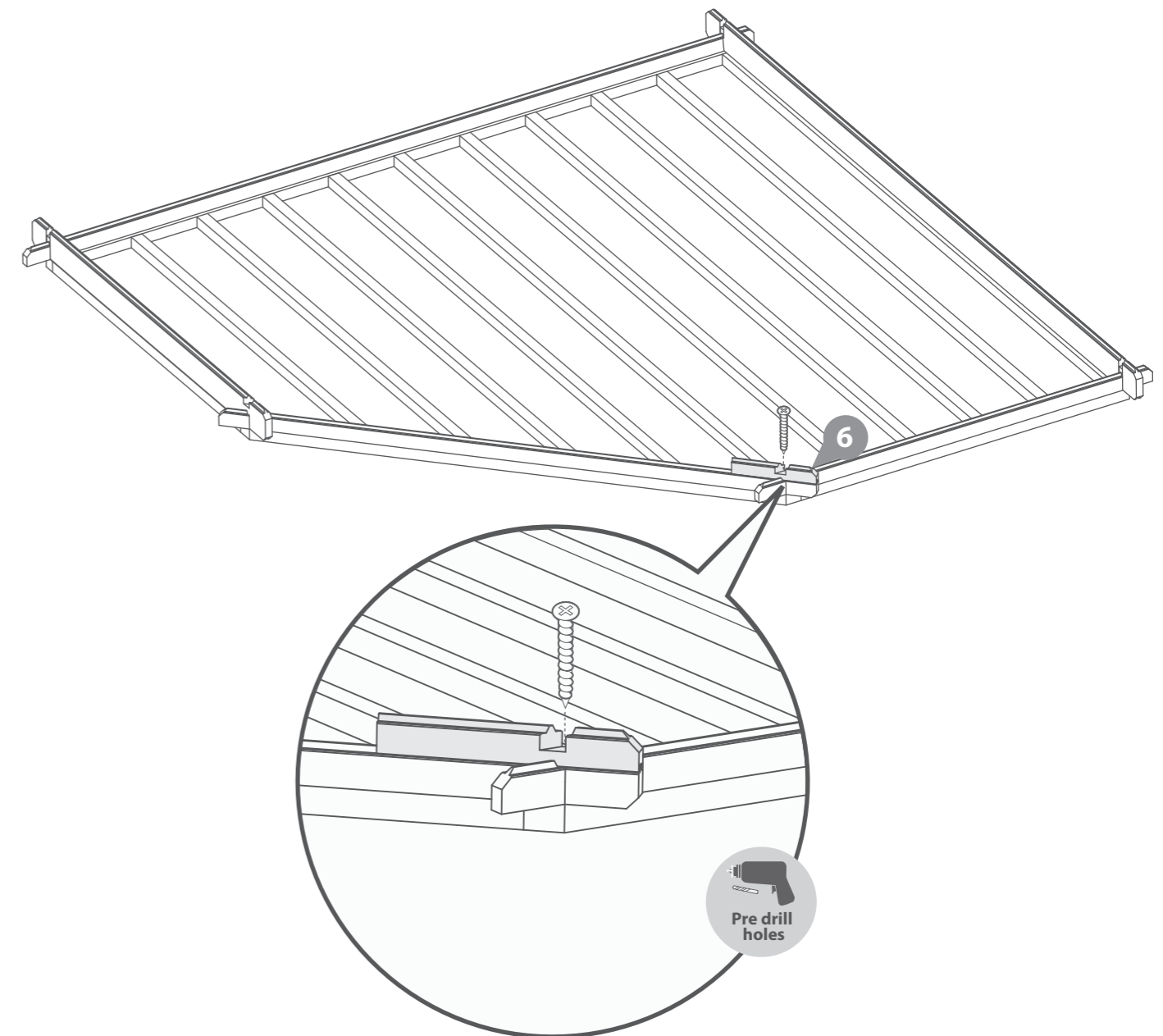
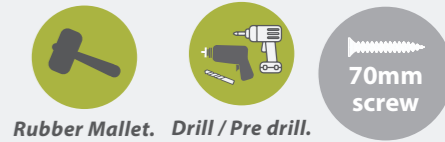

Step 5

- Parts Needed - No. 4 QTY 11**
No. 7 QTY 5
No. 8 QTY 6
No. 9 QTY 6
No. 10 QTY 6

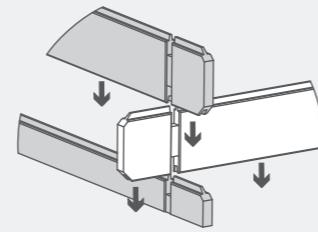

Following the method shown in the illustration, lay the first 6 boards (**No. 4, 7, 8, 9 & 10**) off of the starter boards to create your first level.

**Ensure that the boards are level and flush with each other as you lay each one.*

Start by placing the front and back boards, interlocking them with the side boards. Then place the next side boards, interlocking with the front and back boards. Continue this method until you have placed **6 boards off of the starter boards on each side**, as shown.

Please note the right hand side of the door will be slightly higher. This will even out when the rest has been assembled.



Rubber Mallet.

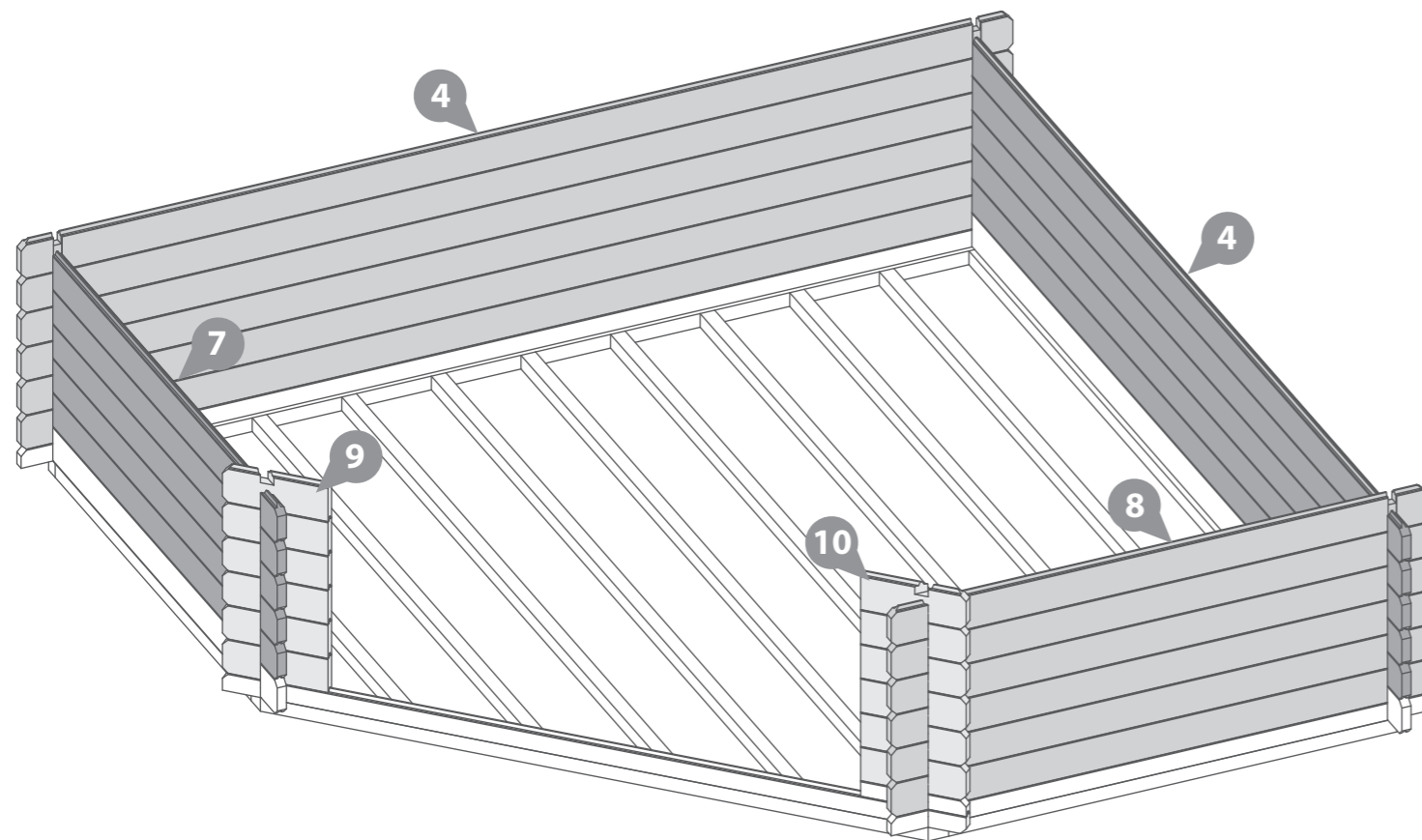

Step 6

- Parts Needed - No. 58 QTY 1**
No. 59 QTY 1
No. 60 QTY 1
No. 61 QTY 1

Arrange the left, right, top & bottom door frames (**No. 58, 59, 60 & 61**) onto a flat and level surface.

Secure the top and bottom frames to the uprights using 2x80mm screws per corner, ensuring the screws do **NOT** protrude through the front of the door framing.

8x80mm Screws
Important: Pre-drill before fixing screws.



Drill / Pre drill.



80mm screw

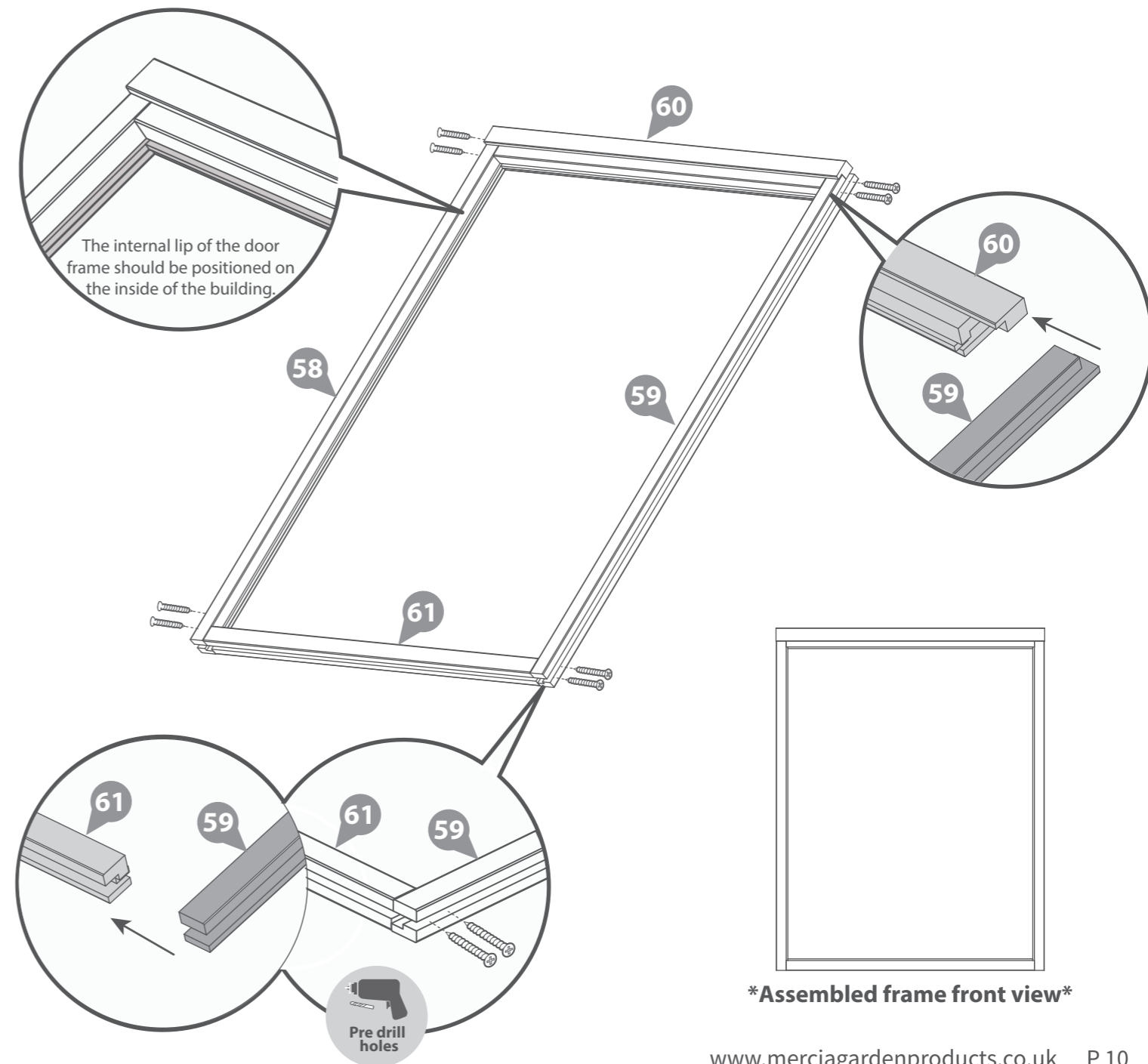

Step 7

Parts Needed - No. 56 QTY 1
No. 57 QTY 1
No. 64 QTY 6

- a** The Adjustable Door Hinge (**No.64**) comes in three parts.
 Fasten parts **No. 64a** and **64b** of the Adjustable Door Hinge together by screwing part **64a** into **64b**, as shown in the illustration.
- b** Place the master and secondary doors (**No. 56 & 57**) into the assembled double door frame, ensuring there is equal spacing on each side between the doors and door frame.

Fix 3 x Adjustable door hinges (**No.64c**) to each door using 3x30mm screws per hinge.

***Ensure the hinges are fitted to the external of the doors so the doors open outwards from the log cabin.**

It is important to fit the doors within the frames at this stage so that you can establish the position of the hinges.

- c** Fix 3 x Adjustable Door Hinges (**No. 64a&b**) onto each door frame using 4x30mm screws per hinge. Ensure the hinges on the doors locate into the hinges on the door frame, and the doors open & close freely without restriction.

***Ensure to screw into the framing and not into the channel.**

- d** Remove the doors from the frame after fitting the hinges. Open the doors and lift them off of the hinges attached to the frames. You do not need to unscrew the hinges to remove the doors.

42x30mm Screw.

Important: Pre-drill before fixing screws.

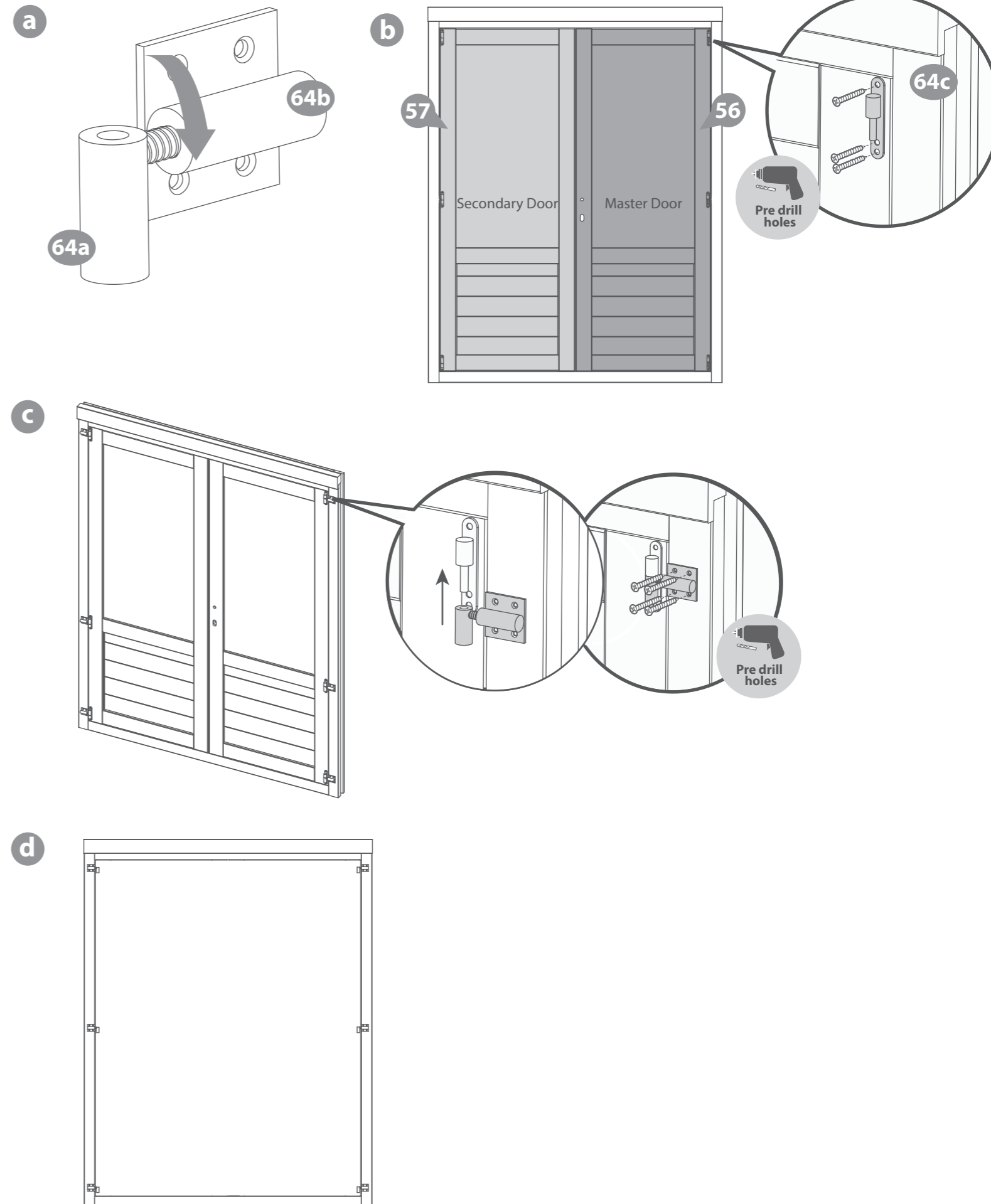
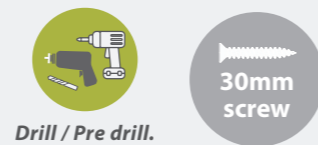

Step 8

To adjust and align your doors:

1. Lift up the doors to separate the two parts of the hinge.
2. Turn the rotating barrel (No.64a) in / out to move the position of the doors either in or away from each other.
3. You can then place the door(s) back on to the hinge and check whether they require more / less adjustments, if further adjustments are required repeat number 2.

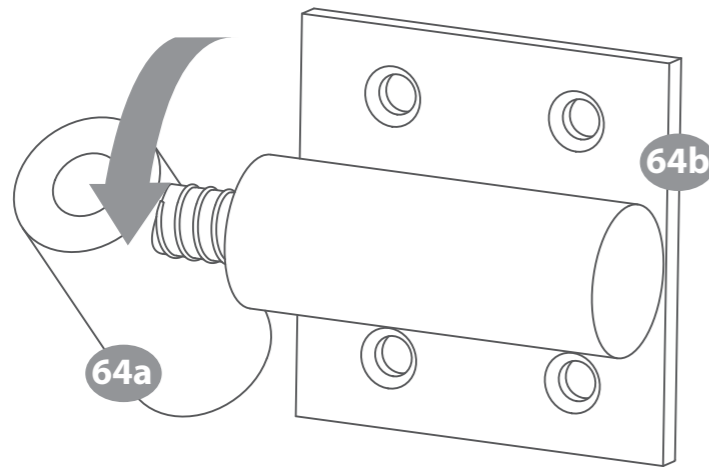

Step 9

Once you have laid 6 log boards (off of the starter board) up the door section, slide the assembled door frame over the boards, ensuring to rest the frame on top of the starter board. *If you have not yet assembled your door frame, please refer to steps 6-8.*



Rubber Mallet.

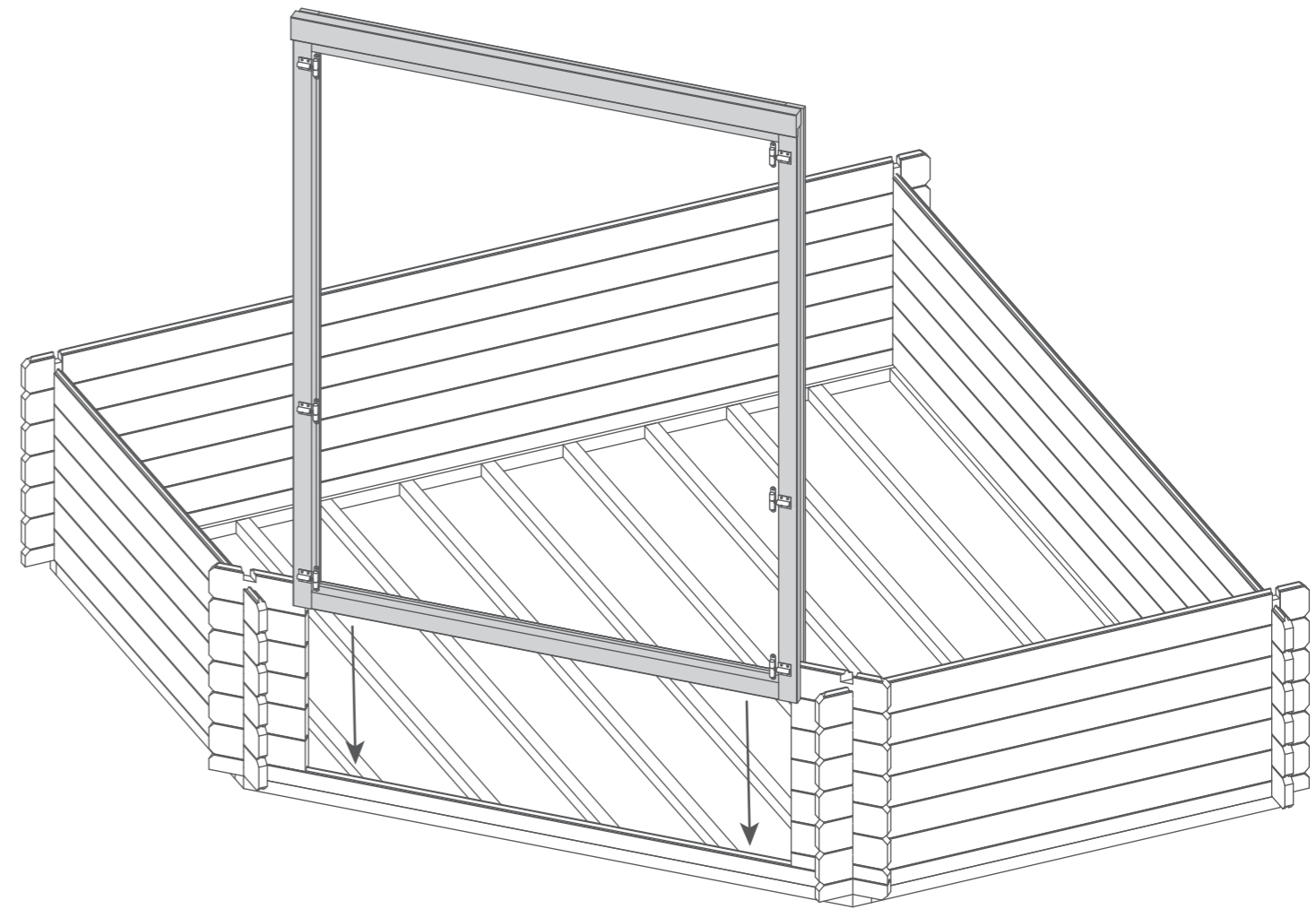

Step 10

- Parts Needed - No. 4 QTY 12**
No. 9 QTY 6
No. 10 QTY 6
No. 11 QTY 12
No. 12 QTY 6
No. 13 QTY 6

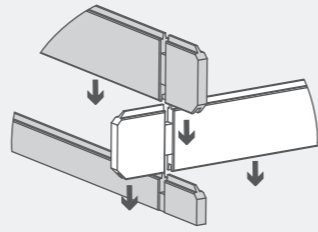

Following the method shown in the illustration, lay the next 6 boards (No. 4, 9, 10, 11, 12 & 13) on to the log cabin to create your second level.



Rubber Mallet.

**Ensure that the boards are level and flush with each other as you lay each one.*

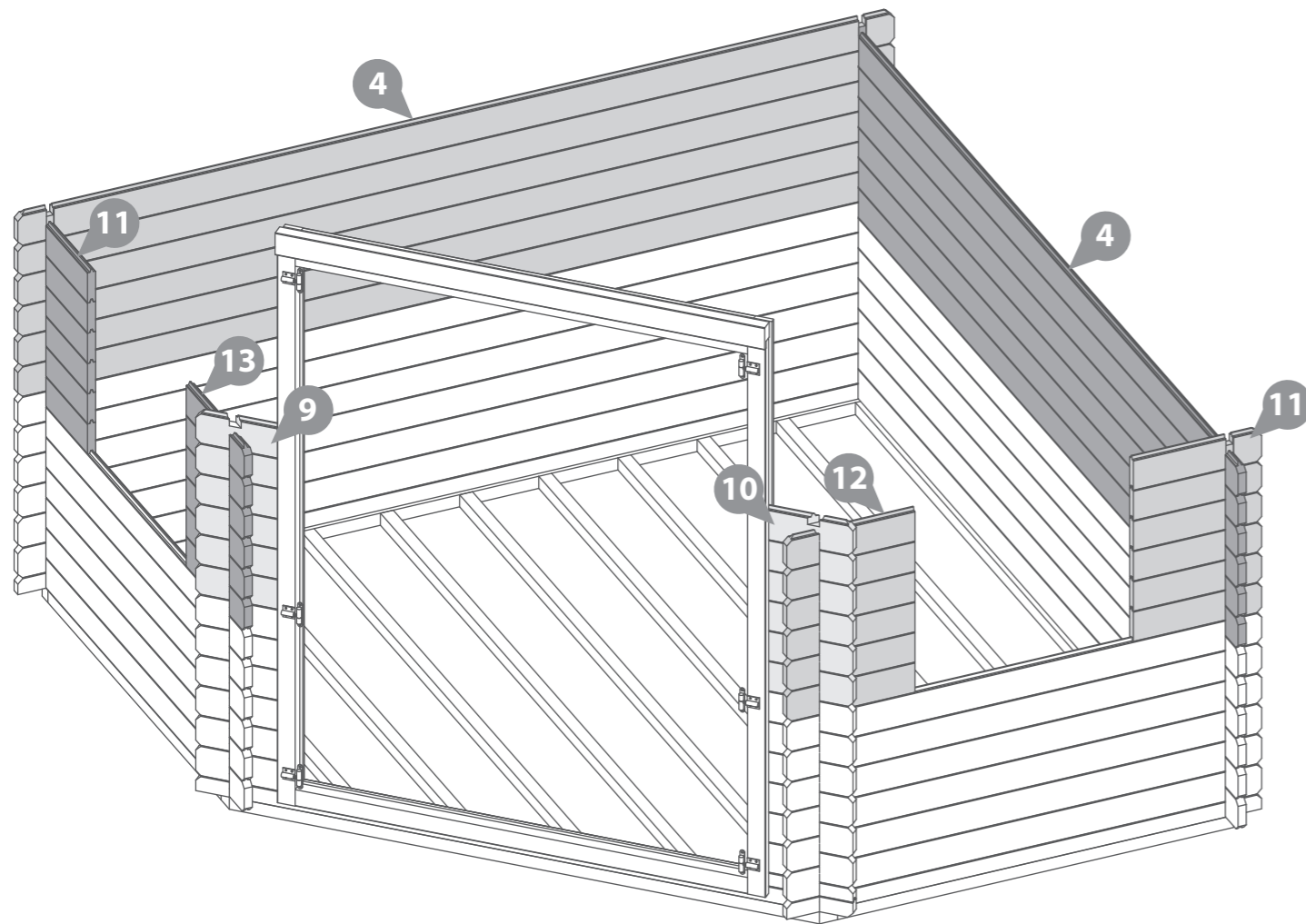

Step 11

- Parts Needed - No. 55 QTY 4**
No. 69 QTY 2
No. 71 QTY 2
No. 73 QTY 4

- a** Open the hinges (**No.71**) following the directional arrow given on the top of the hinge.
- b** Lay the assembled window frame (**No. 69**) on a flat and level surface.

Please note: The window can be hinged to open on either the left or the right, depending on where you position your hinges. Please decide which works best for you before fitting the hinges.

If you want your window to open on the left (from the inside), position the spacers / hinges to the right corners, and if you want your window to open on the right (from the inside), position the spacers / hinges in the left corners.

Place one 2mm spacer (**No. 55**) and one 6mm spacer (**No. 73**) flush together and position them flat onto the inside framing of your chosen hinge position, ensuring they are flush into the corner, as shown.

- c** Position one hinge (**No. 71**) inside the window frame at the top, butt up to the positioned spacers. Ensure the coloured corner cap is flush into the corner of the frame and the straight part of the hinge is flush to the top of the frame. Make sure the hinge opens outwards, away from the frame.

Secure in place using 3x30mm screws.

Repeat to fix the other hinge to the bottom of the frame and remove the spacers.

Use this method to locate and fix two hinges to each of the window frames.

12x30mm Screws.
Important: Pre-drill before fixing screws.

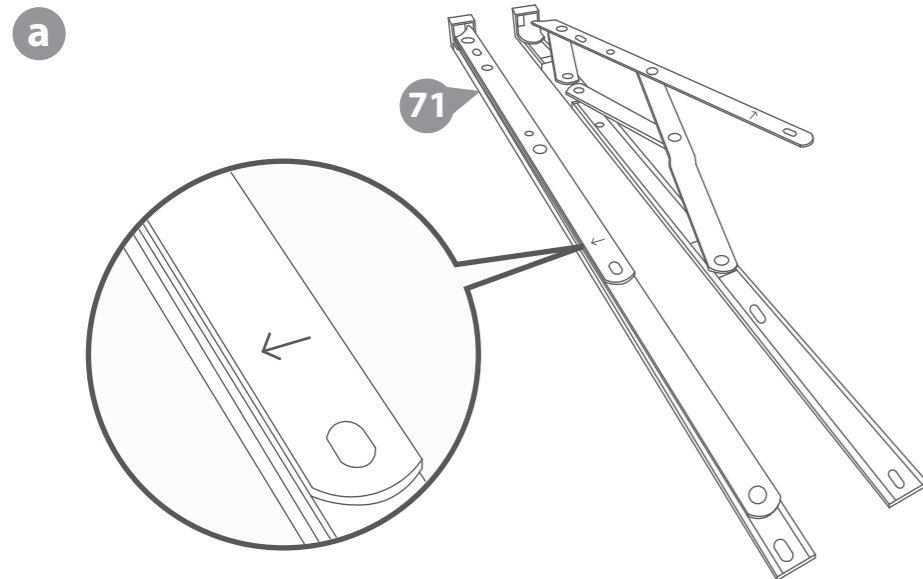
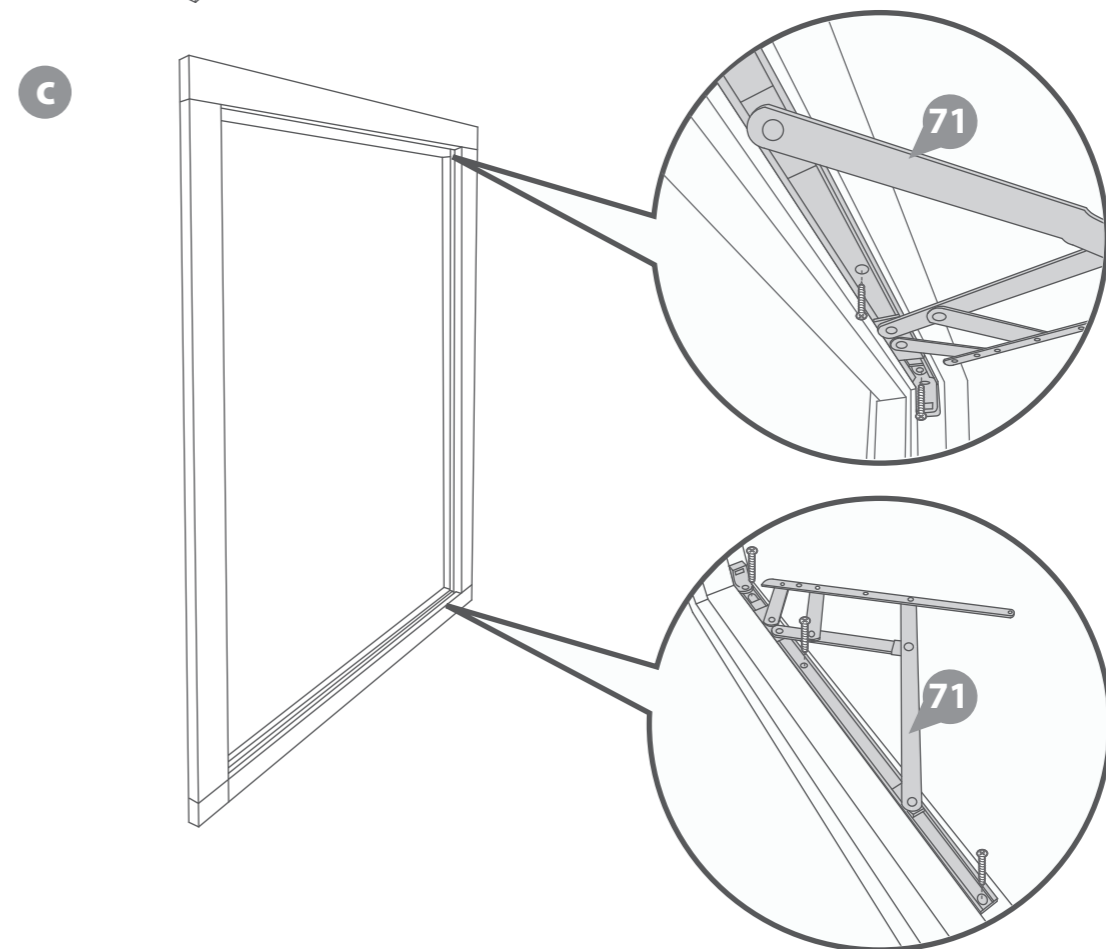
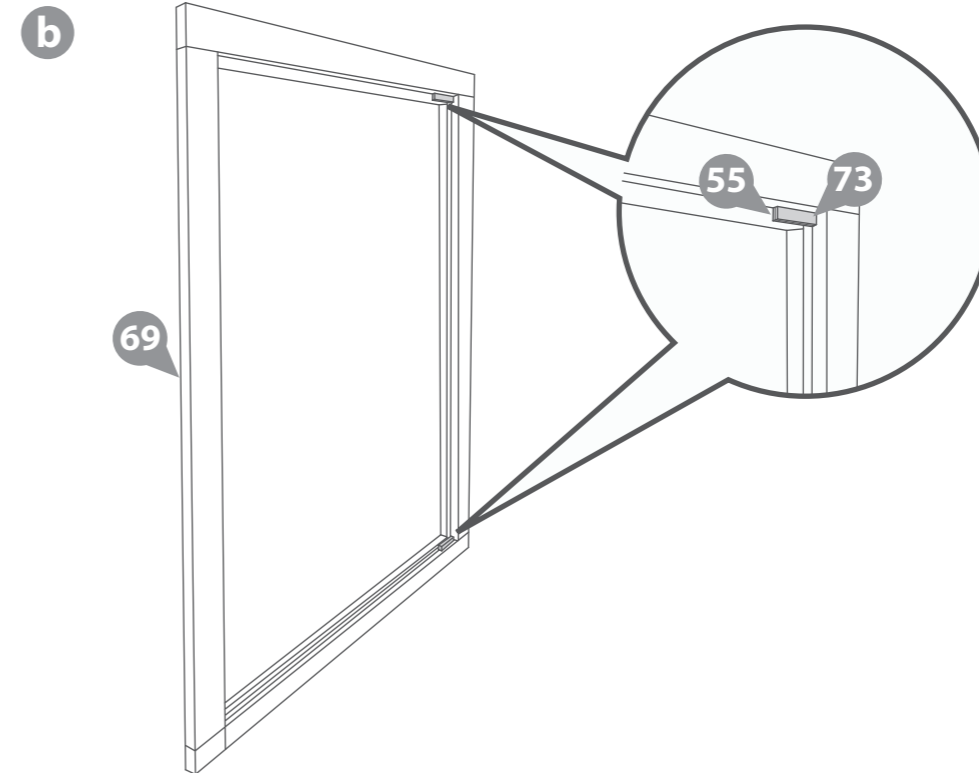

Step 12
Parts Needed - No. 68 QTY 2

- a** With the hinges (**No. 71**) open in the frame, locate the Window (**No. 68**) onto the bottom hinge, ensuring to position both the top and bottom hinge into the groove in the window, as shown.

Fix the hinge to the window using 3x30mm screws per hinge. Ensure the window is able to open and close without getting stuck on the frame.

- b** Once positioned, unscrew and remove the window from the hinges, ensuring to leave the hinges attached to the frame. This will make it easier to fit the window frame into the log cabin.

Use this method to assemble and remove the window from both window frames.

12x30mm Screws.
Important: Pre-drill before fixing screws.



Drill / Pre drill.

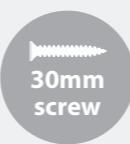

30mm screw

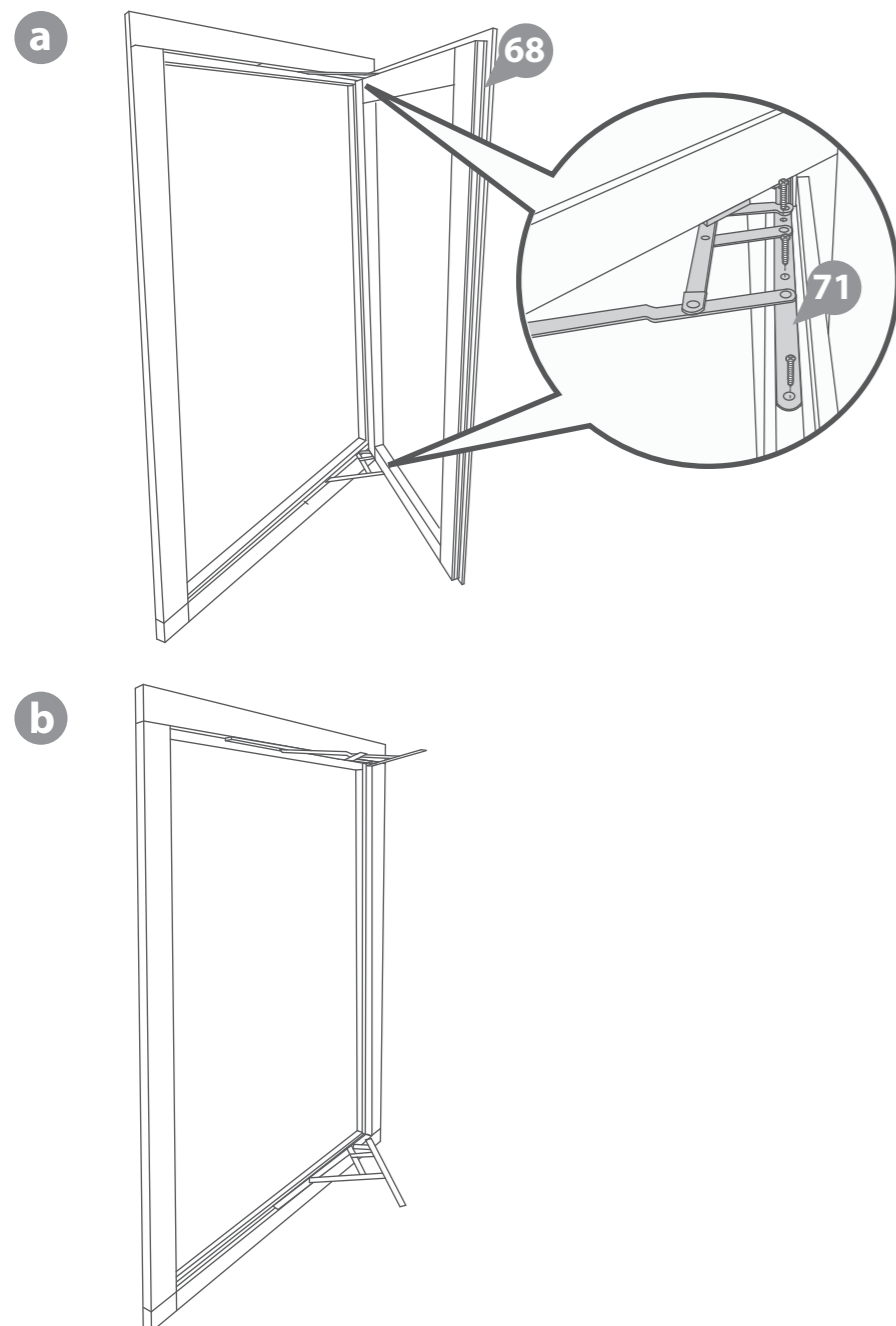

Step 13
Parts Needed - No. 69 QTY 2

Once you have laid 6 log boards up the window sections, slide the assembled Window frames (**No. 69**) over the boards, ensuring to rest the frame on top of the board below. *If you have not yet assembled your window frames, please refer to step 11 & 12.*



Rubber Mallet.

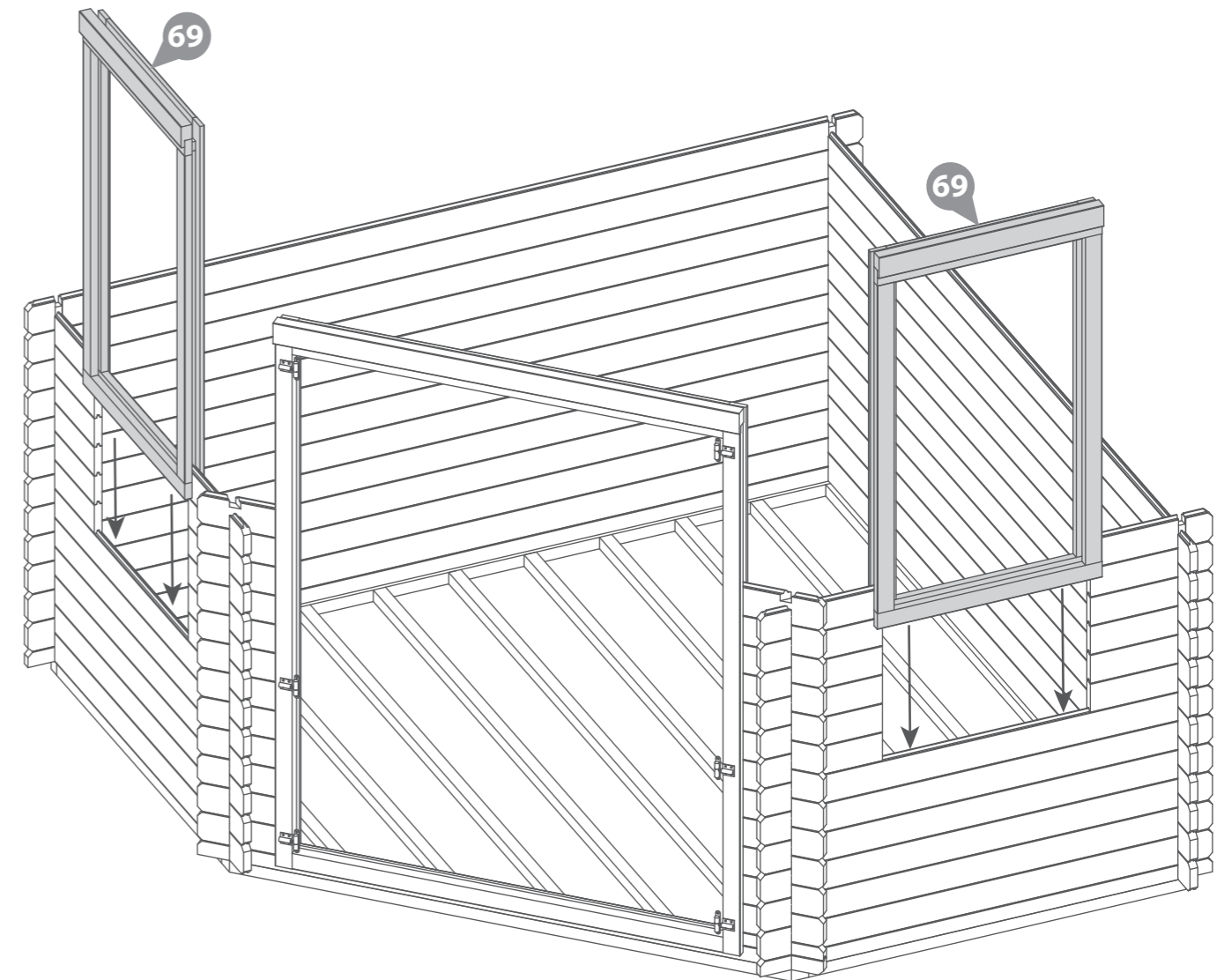

Step 14

- Parts Needed - No. 4 QTY 12**
No. 9 QTY 6
No. 10 QTY 5
No. 11 QTY 12
No. 12 QTY 6
No. 13 QTY 6

Following the method shown in the illustration, lay the next 6 boards (**No. 4, 9, 10, 11, 12 & 13**) to create your next level.

**Ensure that the boards are level and flush with each other as you lay each one.*

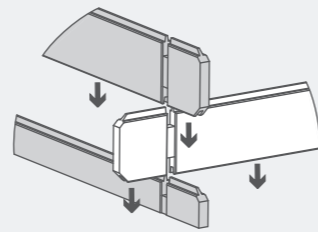

Rubber Mallet.

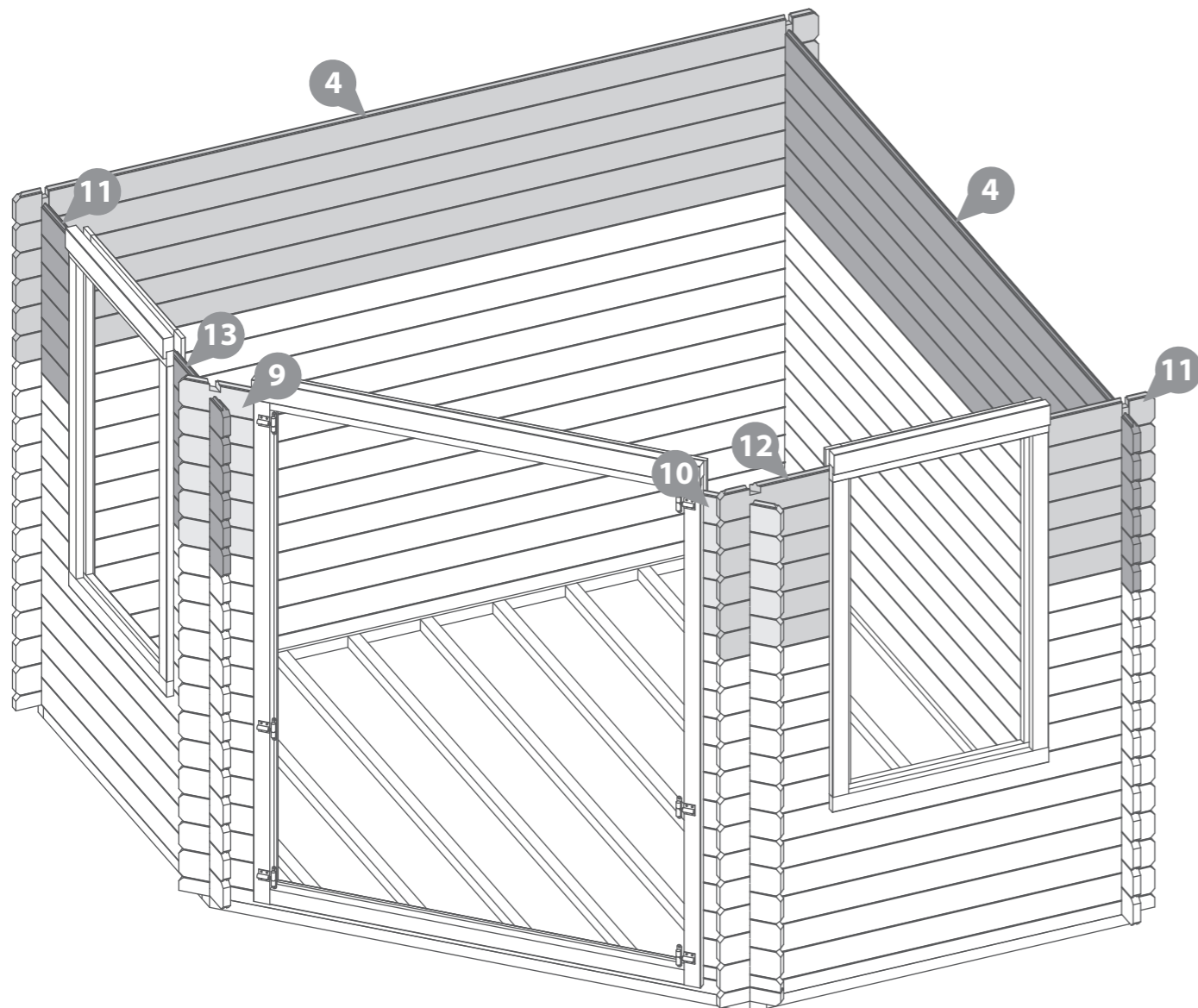

Step 15

- Parts Needed - No. 14 QTY 1**

Make the log cabin level by laying another board (**No. 14**) onto the right side of the cabin, as shown.

**Ensure that the boards are level and flush with each other as you lay each one.*

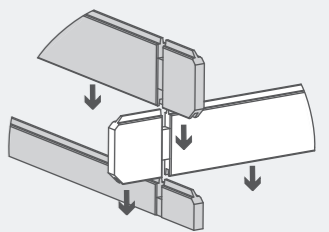

Rubber Mallet.

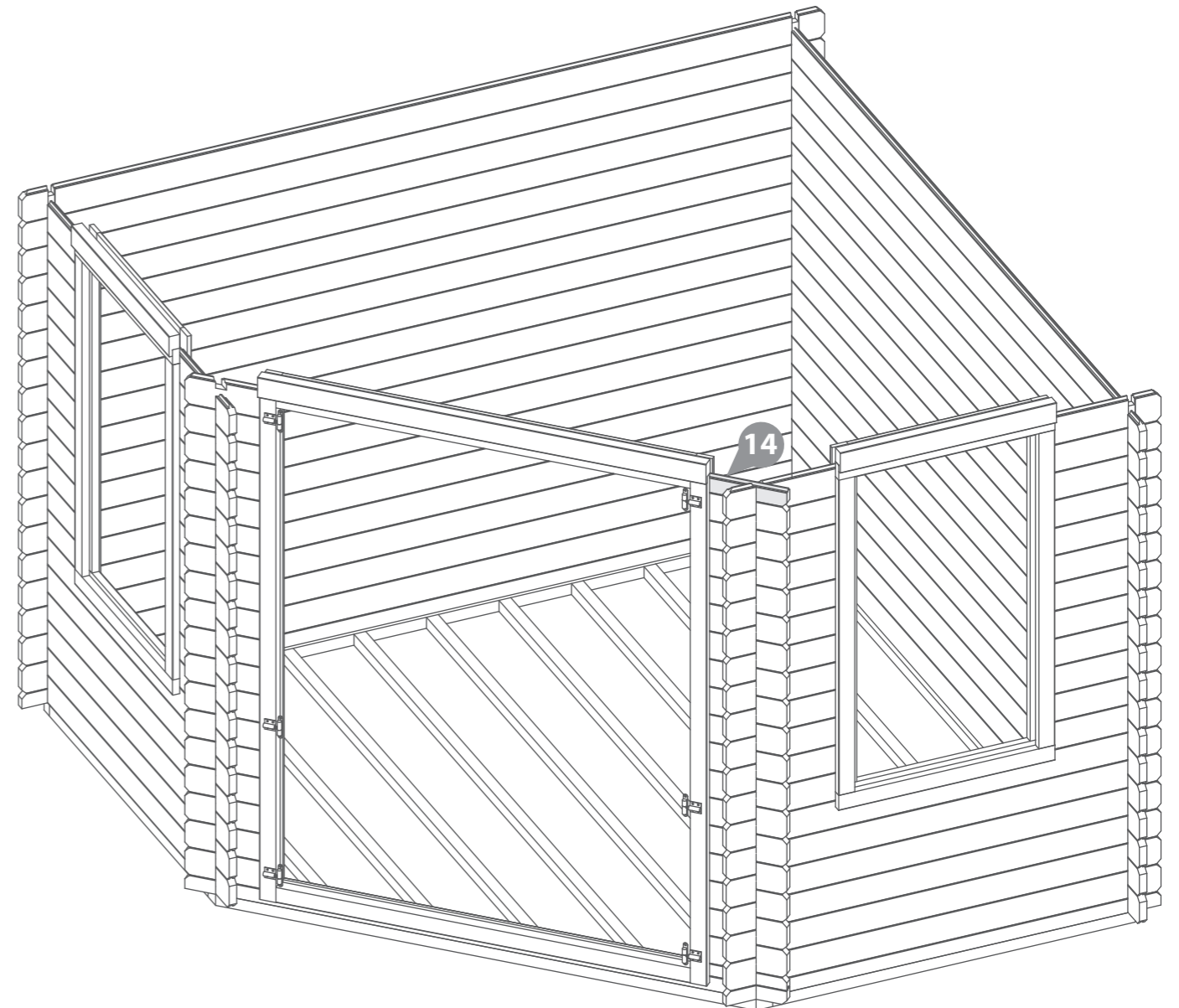

Step 16

- Parts Needed - No. 4 QTY 2
- No. 15 QTY 1
- No. 16 QTY 1
- No. 17 QTY 1

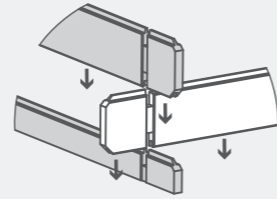

Following the method shown in the illustration, lay the next layer of boards (**No. 4, 15, 16 & 17**) onto the log cabin.

**Ensure that the boards are level and flush with each other as you lay each one.*



Rubber Mallet.

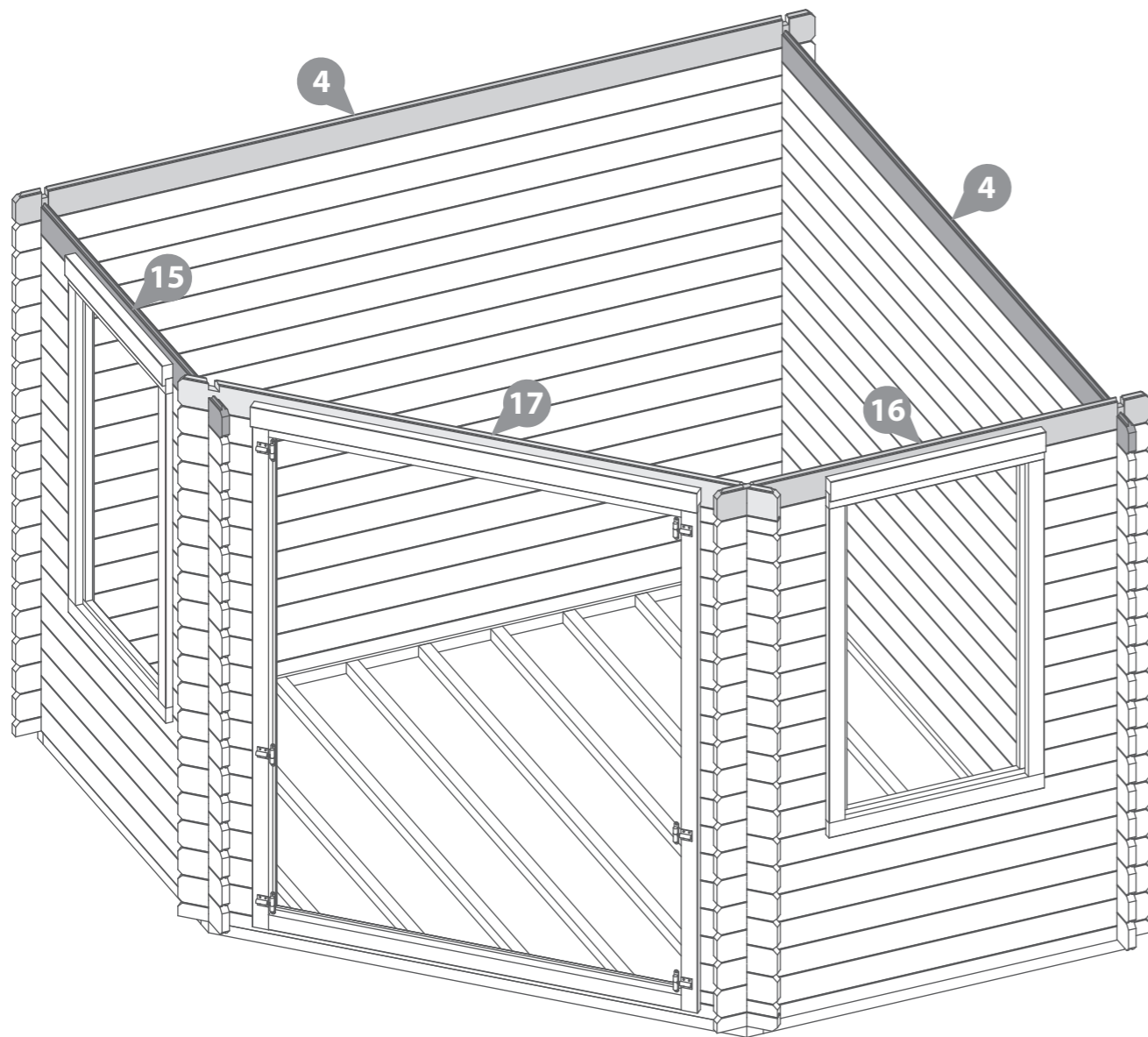

Step 17

- Parts Needed - No. 5 QTY 1
- No. 19 QTY 1
- No. 53 QTY 4

Lay both Boards (**No. 5 & 19**) onto a flat and level surface and locate one Vent (**No. 53**) into each vent hole, as shown. Secure in place using 2x20mm screws per Vent.

Flip the Boards (**No. 5 & 19**) over and position the remaining Vents (**No. 53**) into the opposite side of the Vent holes. Fix in place using 2x20mm screws per vent.

On one side of each board, the vent will need to be slightly offset to an angle to ensure the screws do not collide.

8x20mm Screws.
Important: Pre-drill before fixing screws.



Drill / Pre drill.



20mm screw

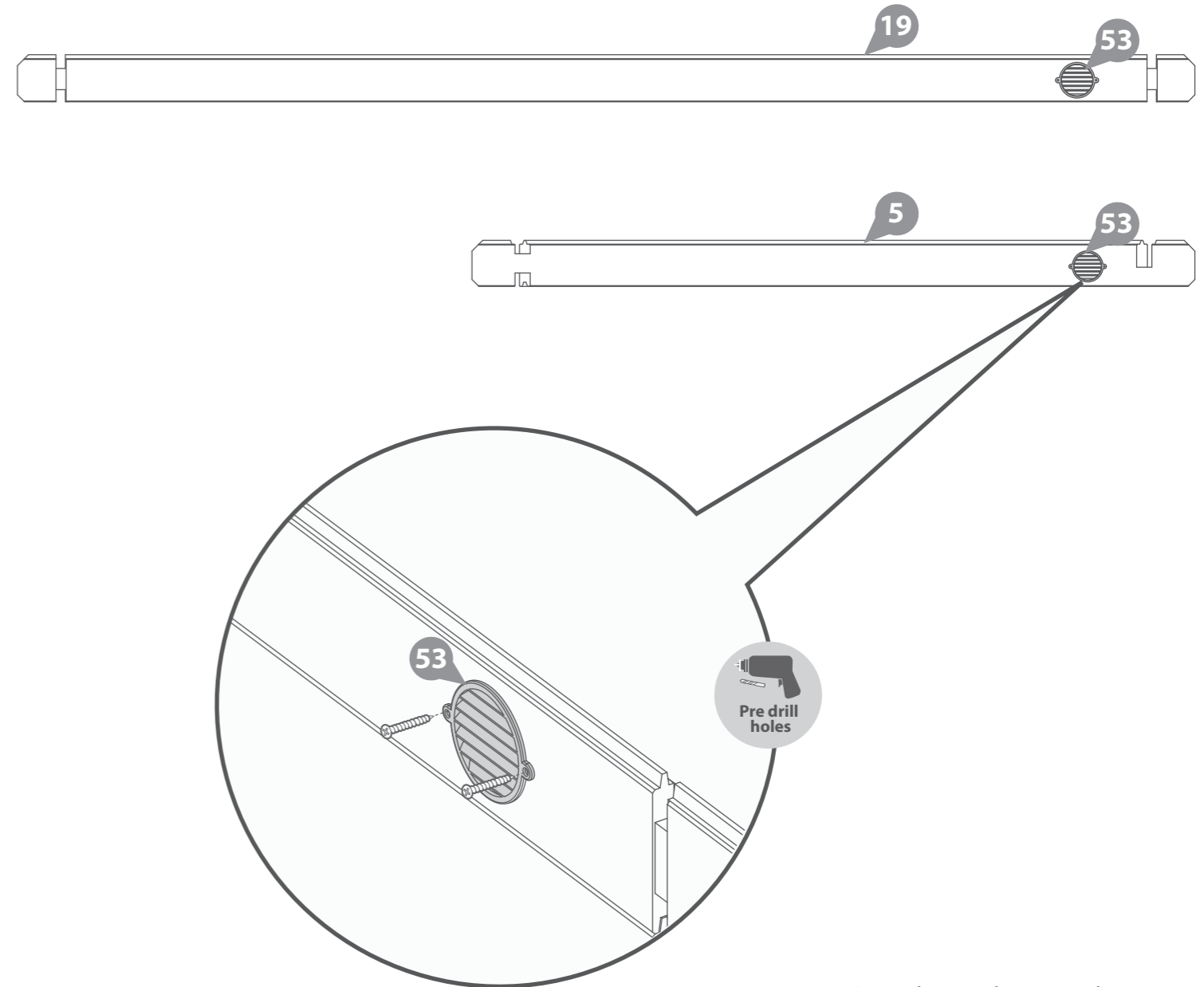

Step 18

- Parts Needed - No. 4 QTY 1**
No. 5 QTY 1
No. 7 QTY 1
No. 18 QTY 1
No. 19 QTY 1

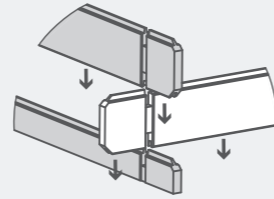

Following the method shown in the illustration, lay the next layer of boards (**No. 4, 5, 7, 18 & 19**) onto the log cabin.

***Ensure that the boards are level and flush with each other as you lay each one.**



Rubber Mallet.

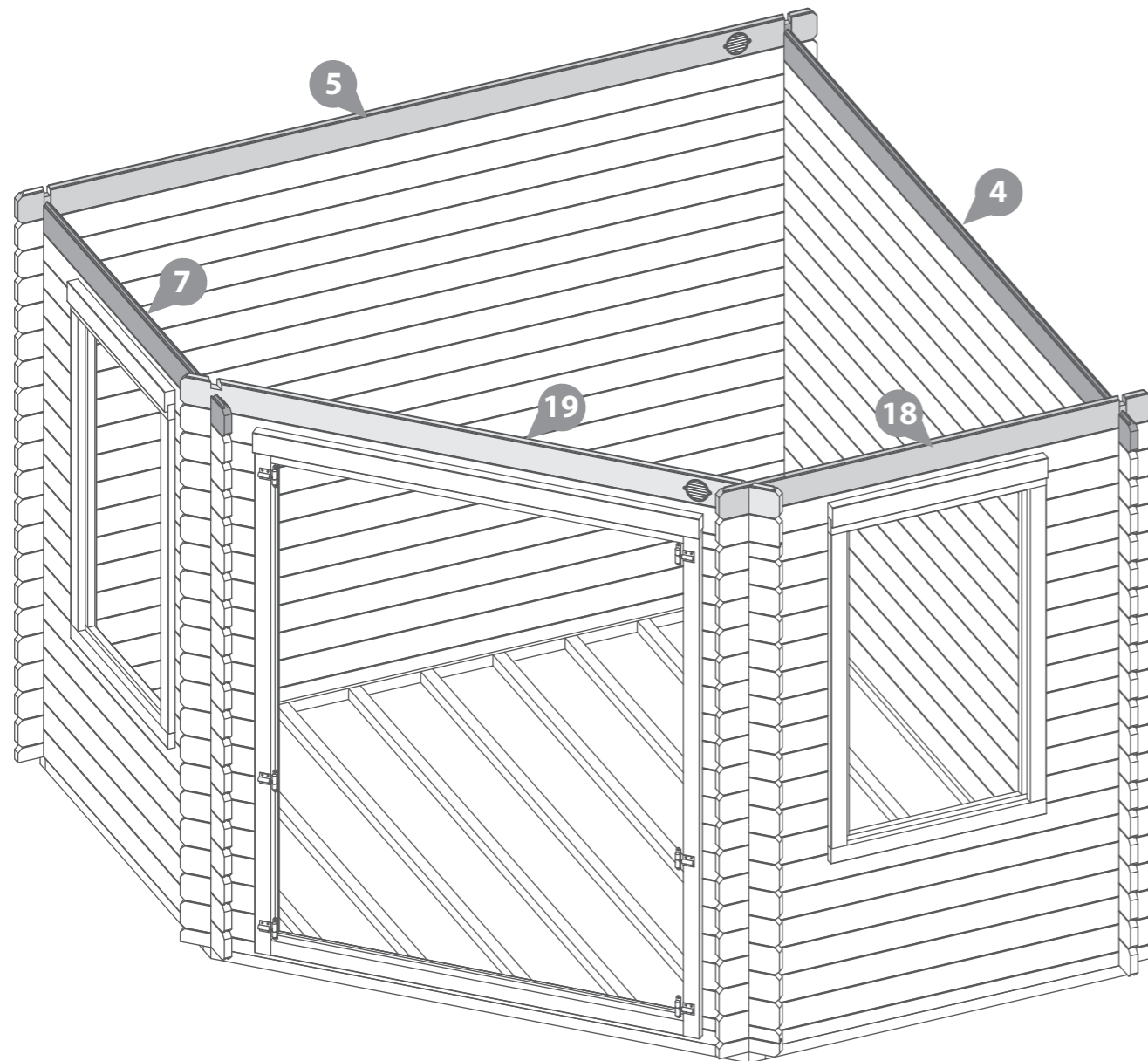

Step 19

- Parts Needed - No. 20 QTY 1**
No. 21 QTY 1

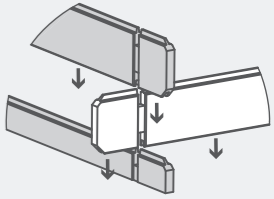

Following the method shown in the illustration, lay the Finisher boards (**No. 20 & 21**) onto the log cabin.

***Ensure that the boards are level and flush with each other as you lay each one.**

Fix each board to the one below by screwing through the notch using 1x70mm screw per corner, as shown in the illustration.

4x70mm Screws
Important: Pre-drill before fixing screws.



Rubber Mallet. Drill / Pre drill.

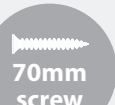

70mm screw

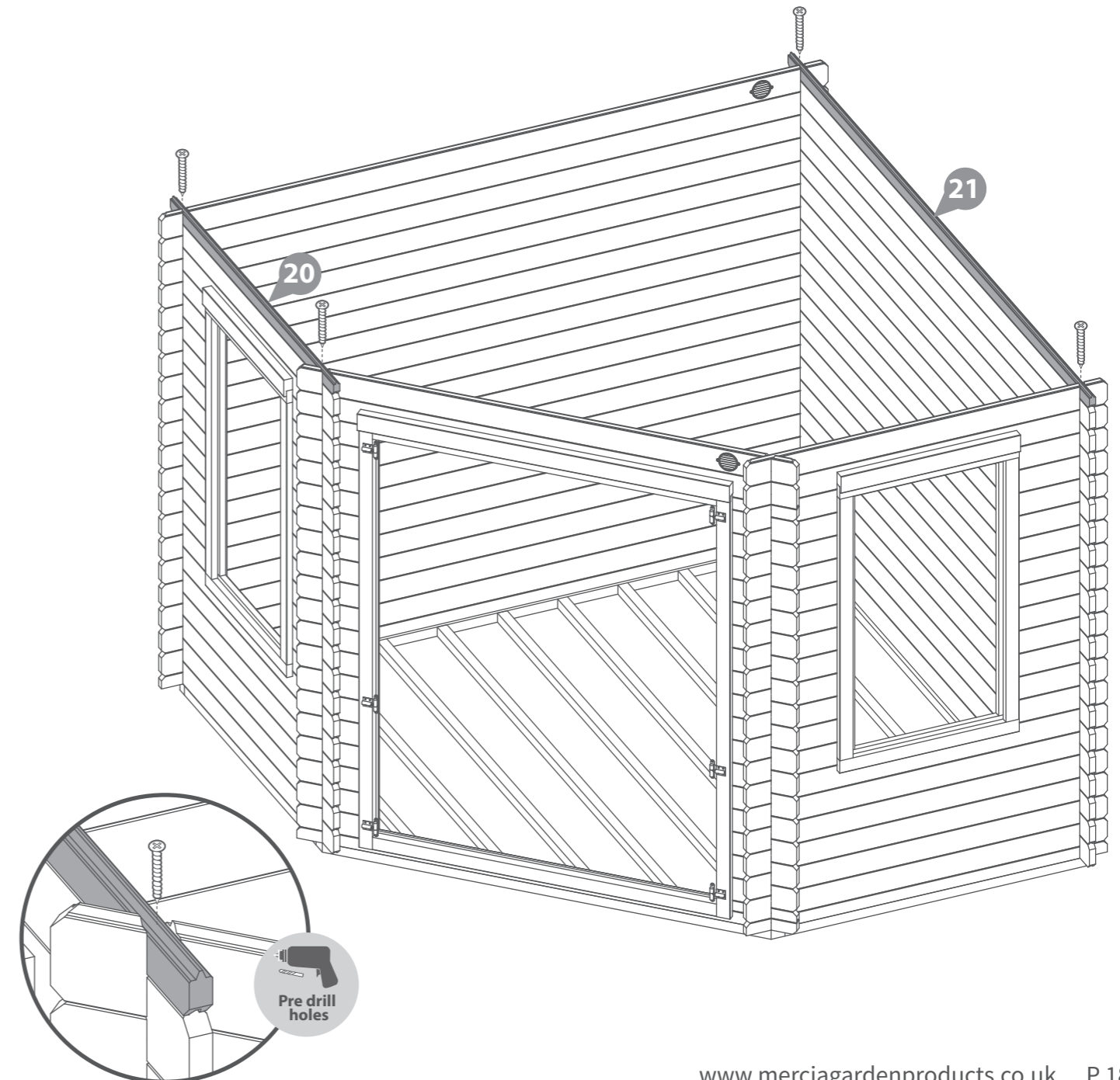

Step 20
Parts Needed - No. 26 QTY 1

**** Please Note:**
You can place your gable on either side of the log cabin, dependant on your needs.
(See Contents page for reference).
Please ensure to construct your Roof by following either 'Roof Assembly 1' or 'Roof Assembly 2', dependant on which side you place the Gable.

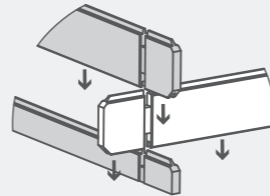

Following the method shown in the illustration, locate the Gables (No. 26) onto the log cabin.

***Ensure that the boards are level and flush with each other as you lay each one.**

Fix the gables to the boards below by screwing through the notch using 1x120mm screw per corner, as shown in the illustration.

2x120mm Screws
Important: Pre-drill before fixing screws.



Roof Assembly 1

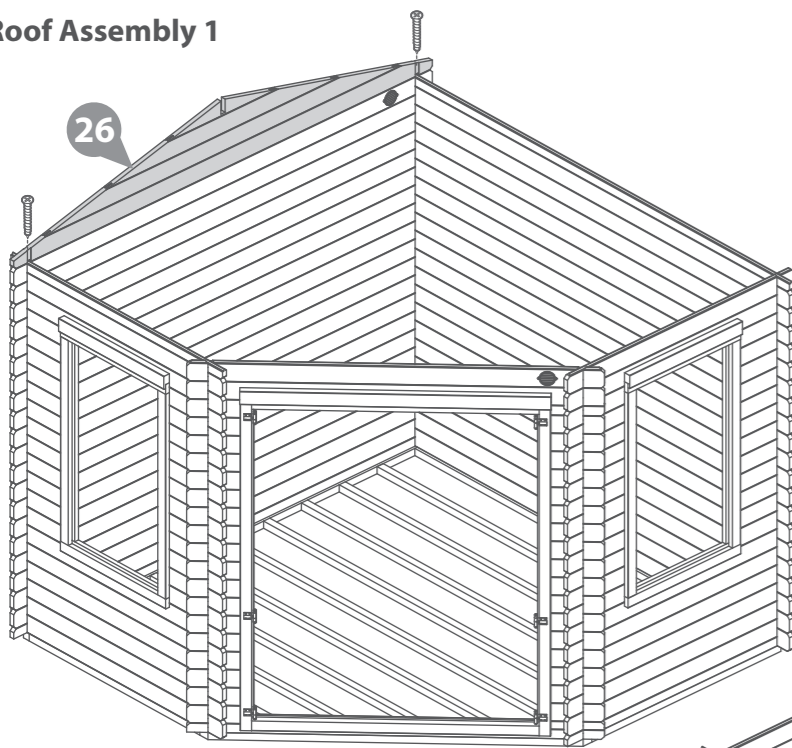

Roof Assembly 2

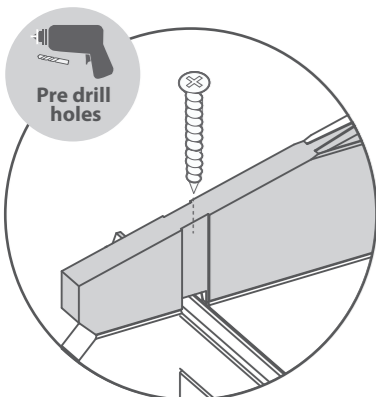
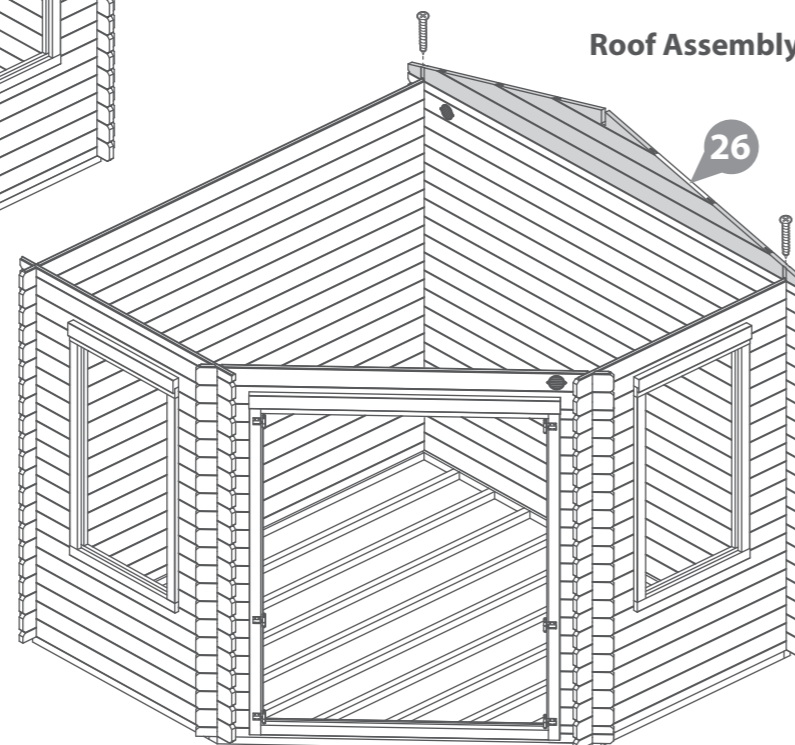

Step 21
Parts needed - No. 33 QTY 1

Align the Purlin (No.33) into the cut out notch on the Gable, ensuring they interlock.

Note: Use a mallet and a scrap piece of wood to gently fix the purlins into position.



Rubber Mallet.

Roof Assembly 1

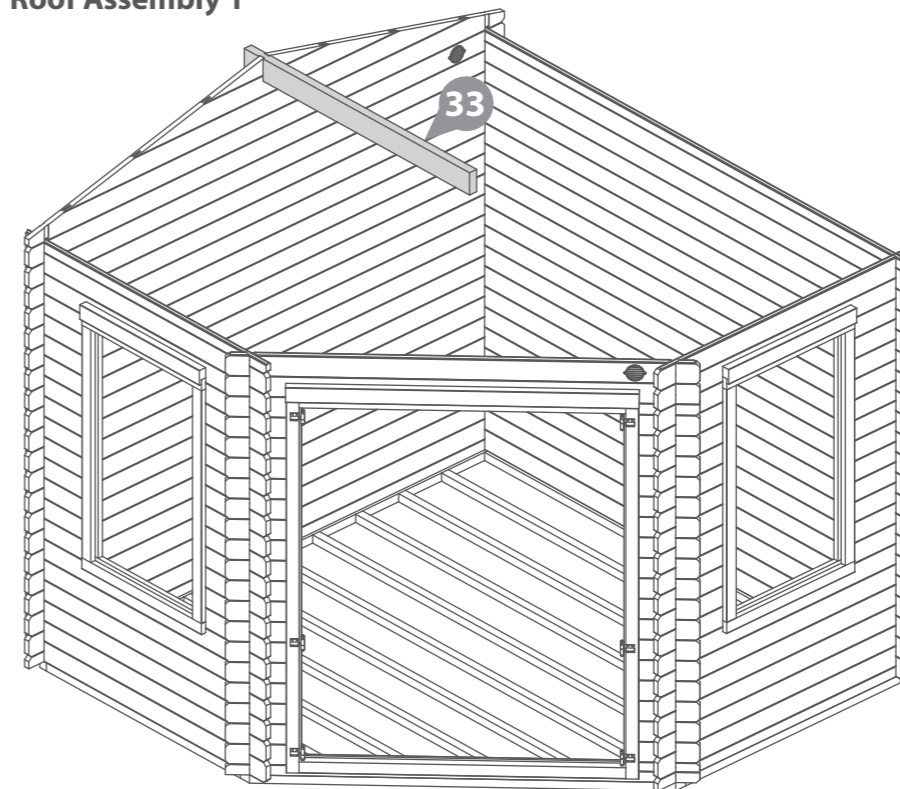

Roof Assembly 2

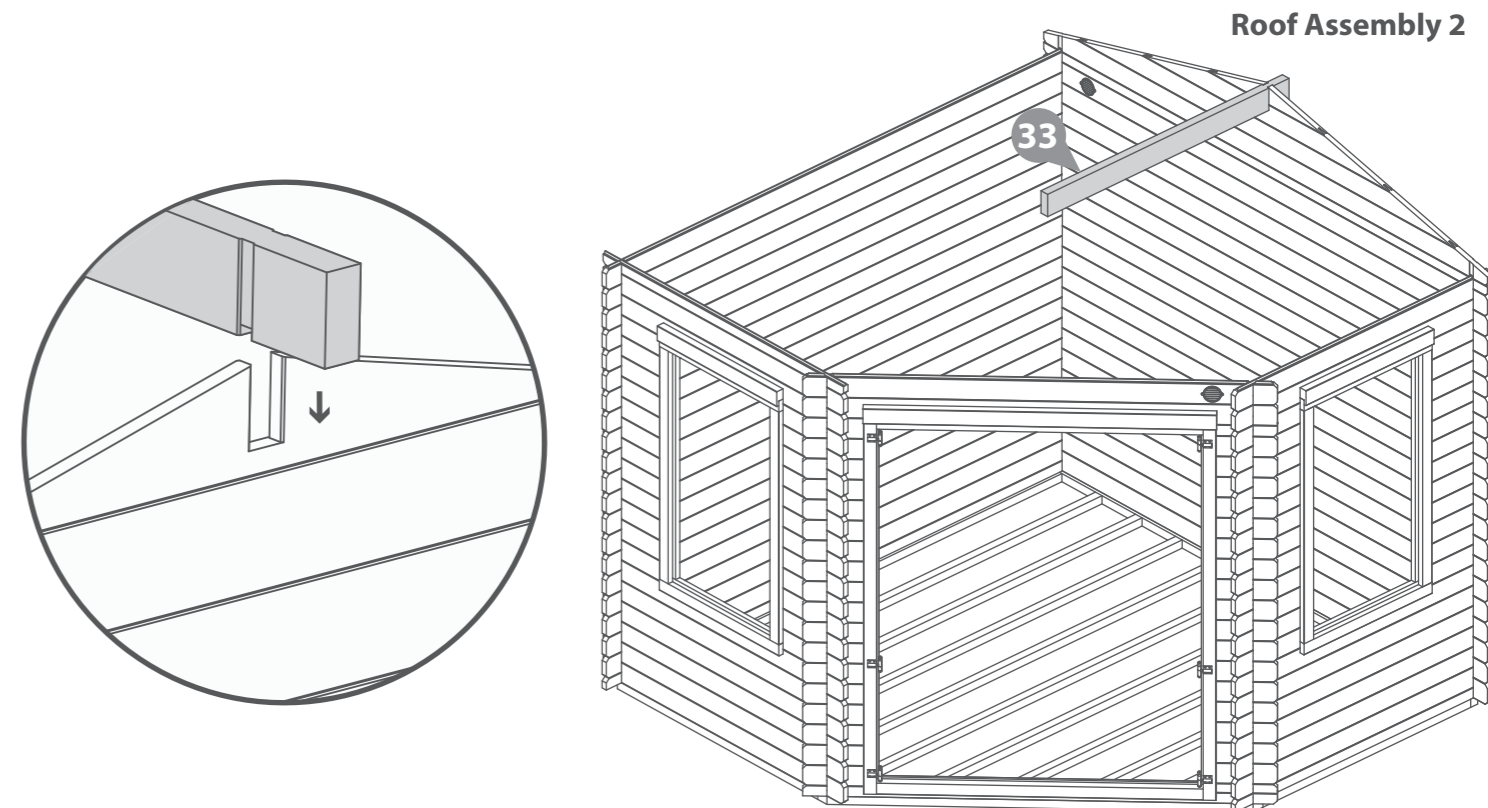

Step 22 - Roof Assembly 1

Parts needed - No. 29 QTY 1

No. 31 QTY 1

No. 32 QTY 1

Place the Central roof Truss ' Roof Truss D (No.32) flush to the end of the Roof Purlin (No. 33)

Place Roof Truss C (No.31) and Roof Truss A (No.29) onto either side of the Roof Purlin (No.33) ensuring they sit flush to the end, creating a 'T' shape as shown in the illustration.

Fix in place by screwing through the truss into the end of the Purlin at an angle, as shown, using 1x90mm screw per truss.

3x90mm Screws

Important: Pre-drill before fixing screws.



Rubber Mallet.



Drill / Pre drill.

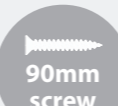

90mm screw

Roof Assembly 1

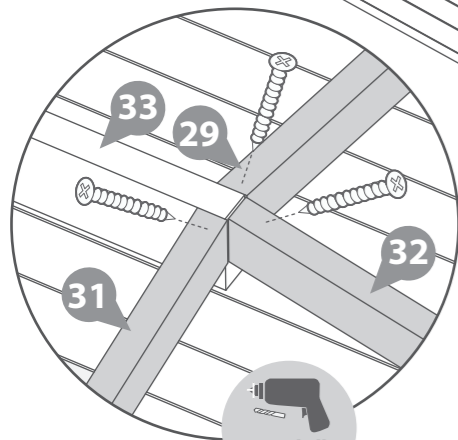
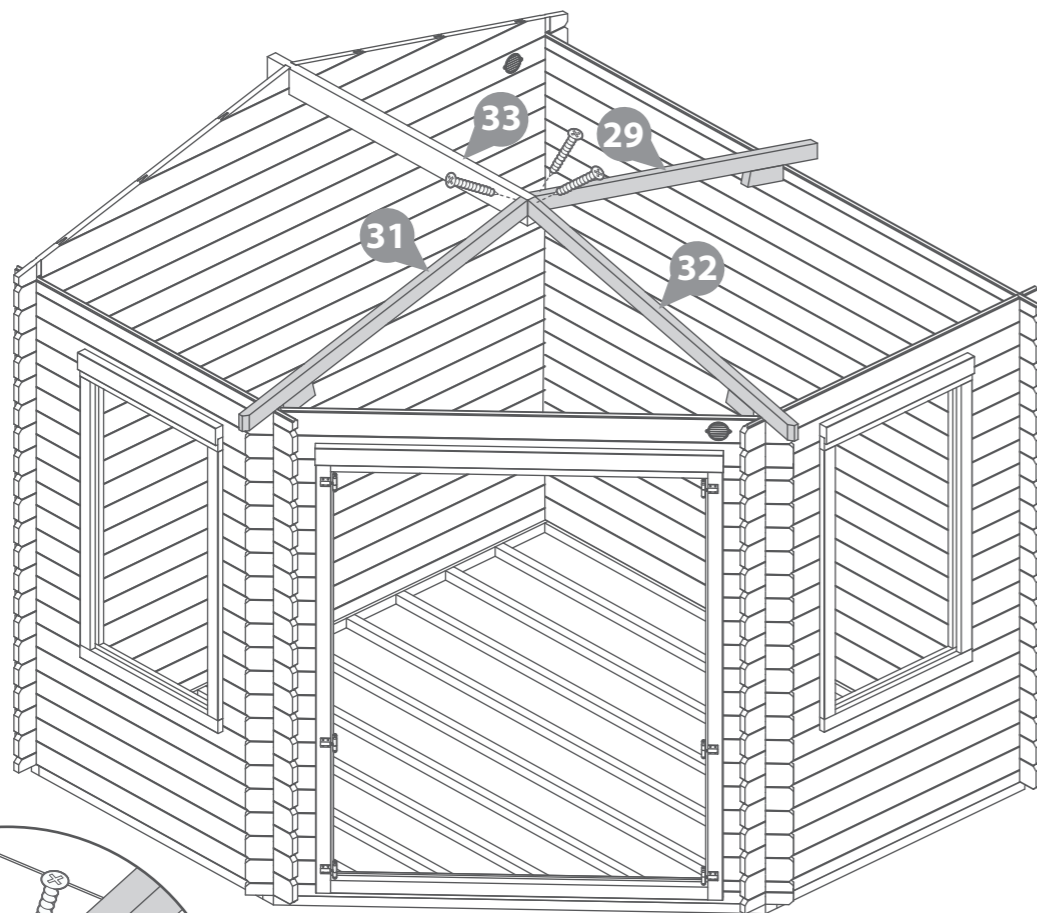

Pre drill holes

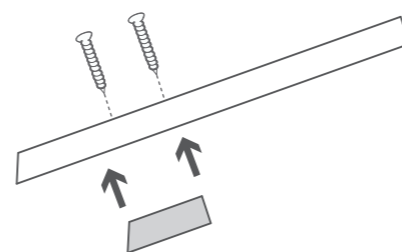

Please note: You can adjust the blocks attached to the roof truss' if necessary.

Step 22 - Roof Assembly 2

Parts needed - No. 29 QTY 1

No. 31 QTY 1

No. 32 QTY 1

Place the Central roof Truss Roof Truss C (No.31) flush to the end of the Roof Purlin (No. 33)

Place Roof Truss D (No.32) and Roof Truss A (No.29) onto either side of the Roof Purlin (No.33) ensuring they sit flush to the end, creating a 'T' shape as shown in the illustration.

Fix in place by screwing through the truss into the end of the Purlin at an angle, as shown, using 1x90mm screw per truss.

3x90mm Screws

Important: Pre-drill before fixing screws.



Rubber Mallet.



Drill / Pre drill.

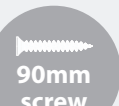

90mm screw

Roof Assembly 2

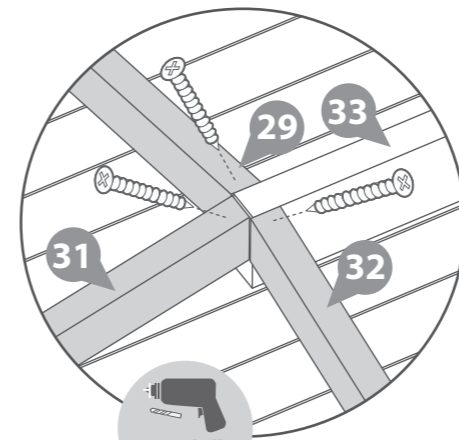
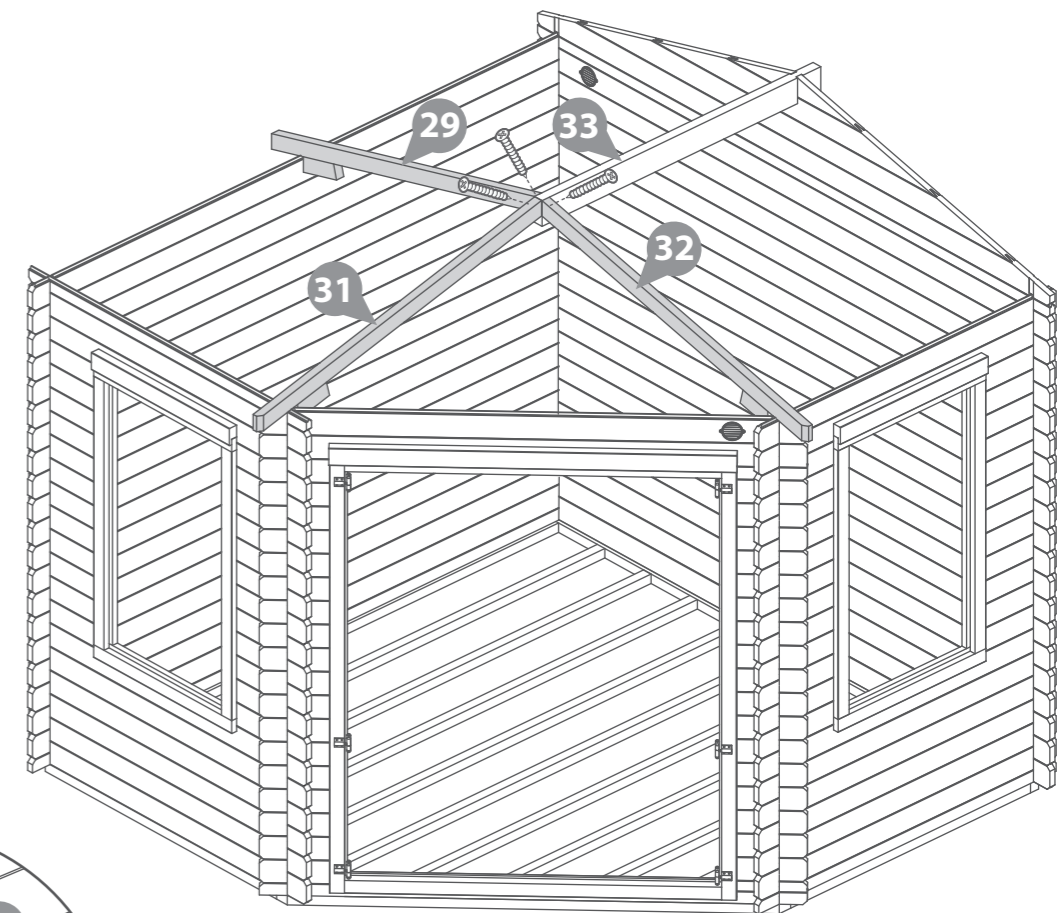

Pre drill holes

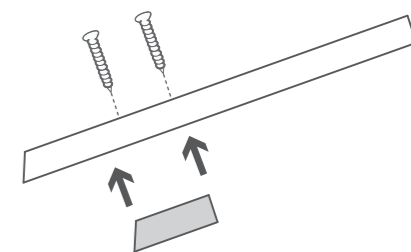

Please note: You can adjust the blocks attached to the roof truss' if necessary.

Step 23
Parts needed - No. 30 QTY 1

Place 'Roof Truss B' (No. 30) between Roof Truss A (No.29) and the Central Roof Truss (Truss D for Roof Assembly 1, and Truss C for Roof Assembly 2) as shown in the illustration.

Fix in place by screwing into the purlin at an angle as shown using 1x90mm screw.

***Ensure to stagger screws to avoid screws colliding.**

1x90mm Screws
Important: Pre-drill before fixing screws.



Roof Assembly 1

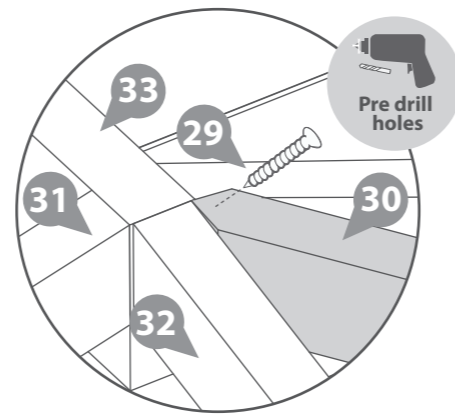
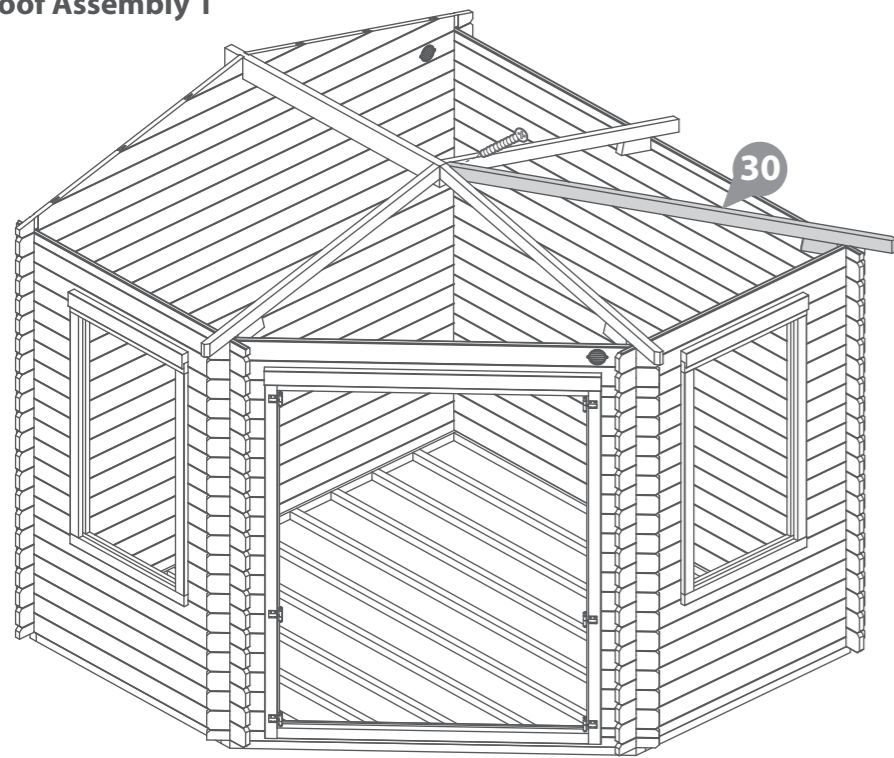

Roof Assembly 2

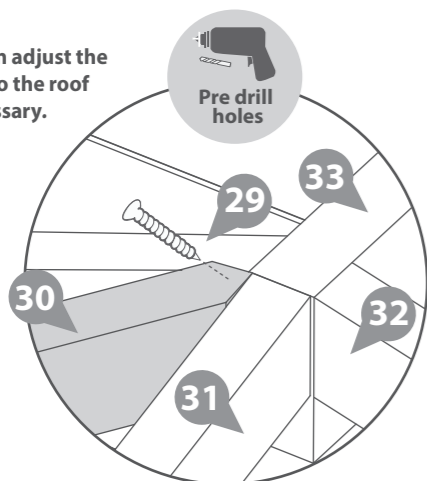
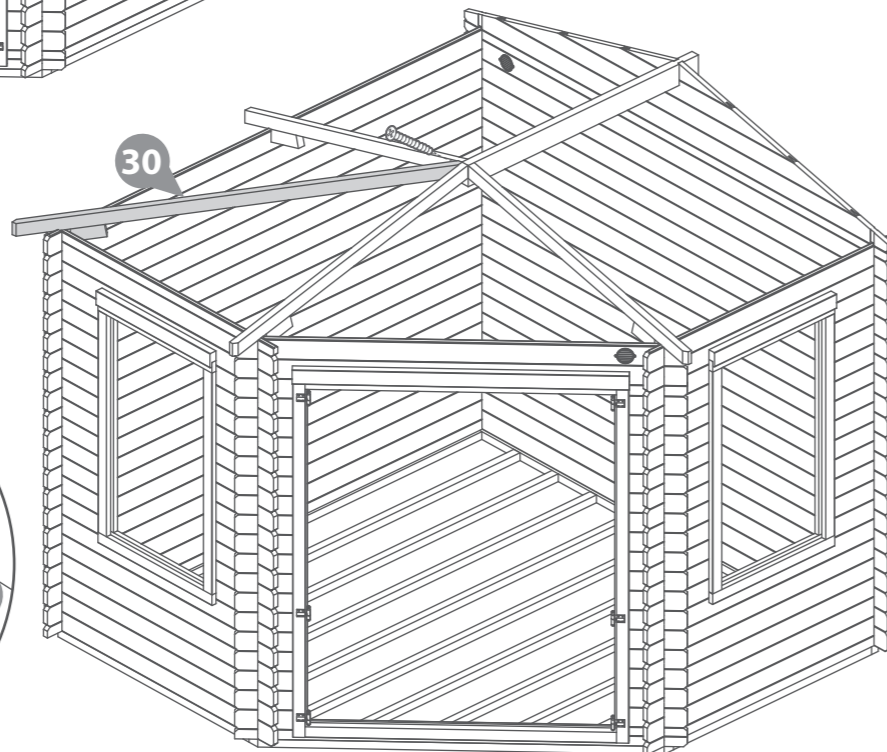

Please note: You can adjust the blocks attached to the roof truss' if necessary.

Step 24
Parts needed - No. 29 QTY 2

Place one 'Roof Truss A' (No. 29) flush to the inside of the gable on either side of the Purlin.

Fix in place by screwing into the purlin at an angle using 1x90mm screws per Roof Truss, as shown.

***Ensure to stagger screws to avoid screws colliding.**

2x90mm Screws
Important: Pre-drill before fixing screws.



Roof Assembly 1

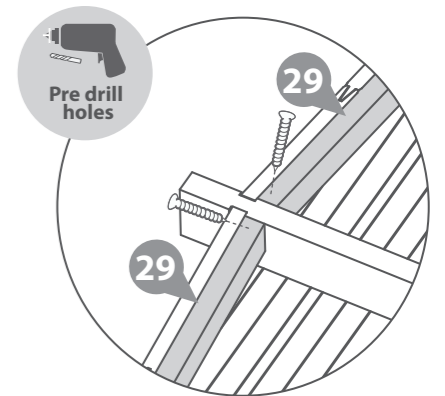
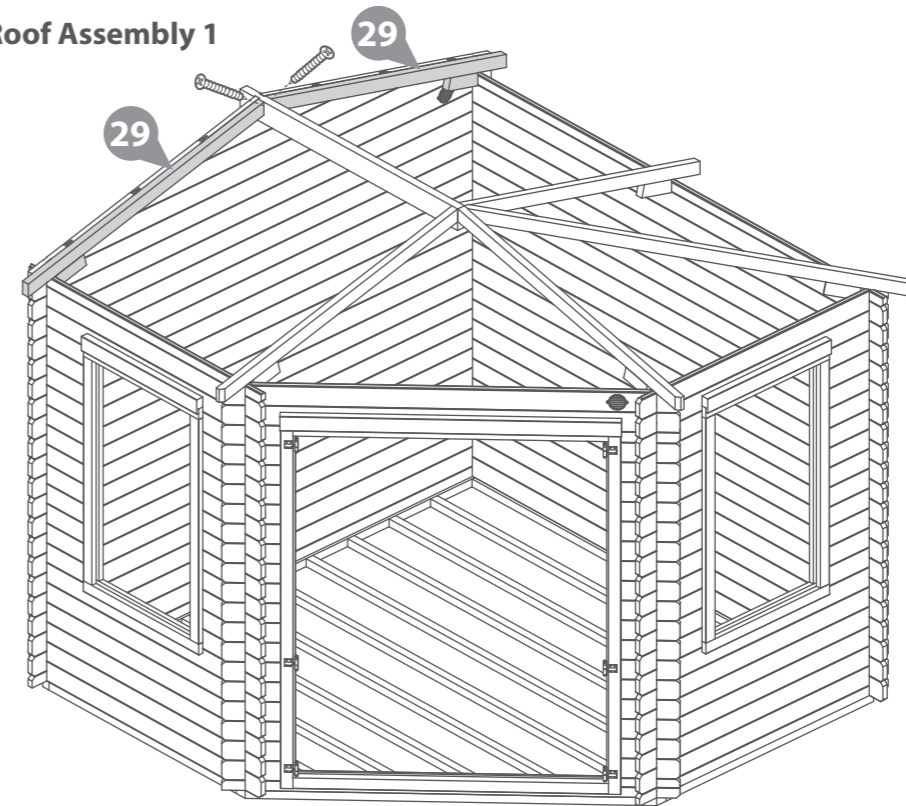

Roof Assembly 2

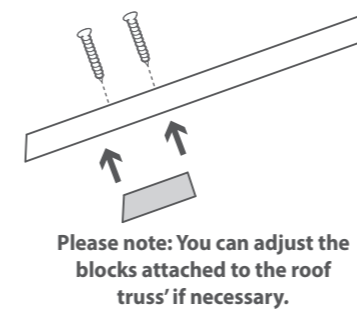
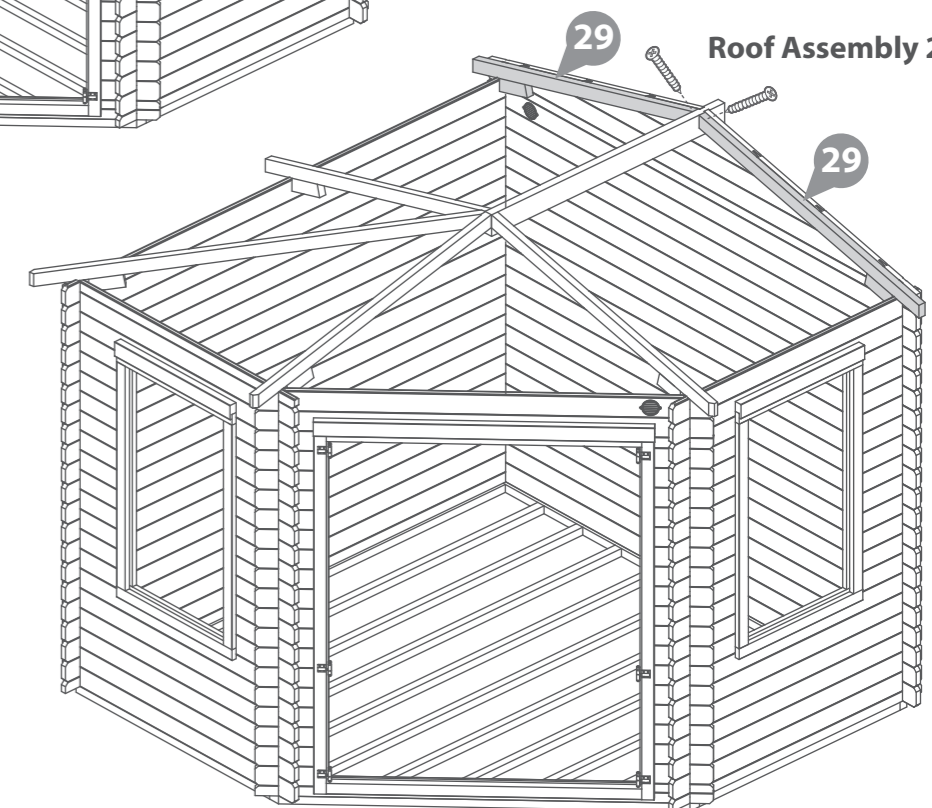

Please note: You can adjust the blocks attached to the roof truss' if necessary.

Step 25

**Parts needed - No. 27 QTY 1
No. 28 QTY 1**

Position the Left and Right Roof Truss' (No. 27 & 28) up against 'Roof Truss B' (No.30), ensuring the angled sides are flush to the long framing of Roof Truss B and that the blocks are flush against the cabin walls, as shown.

Secure the Truss' (No. 27 & 28) to Truss B (No.30) using 1x90mm screws per truss.

**Ensure to stagger screws to avoid screws colliding.*

2x90mm Screws
Important: Pre-drill before fixing screws.



Roof Assembly 1

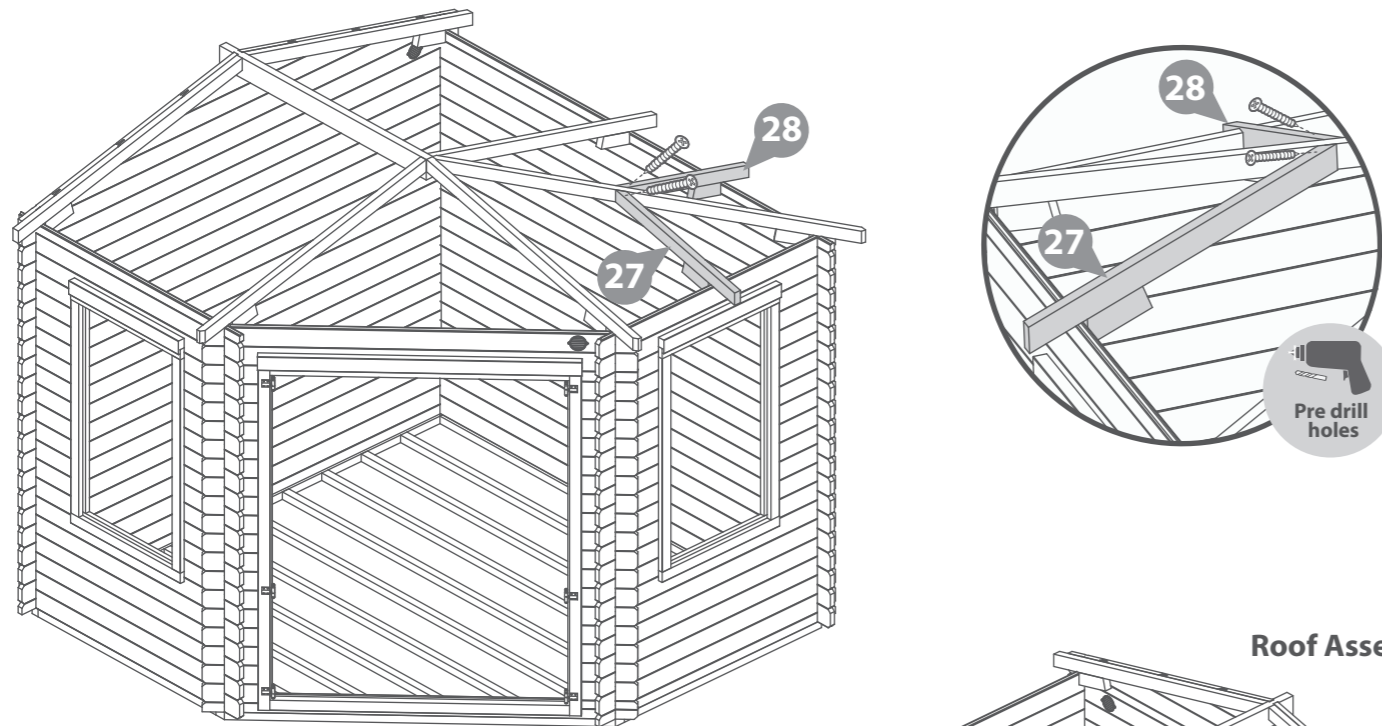

Roof Assembly 2

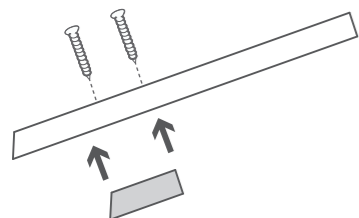
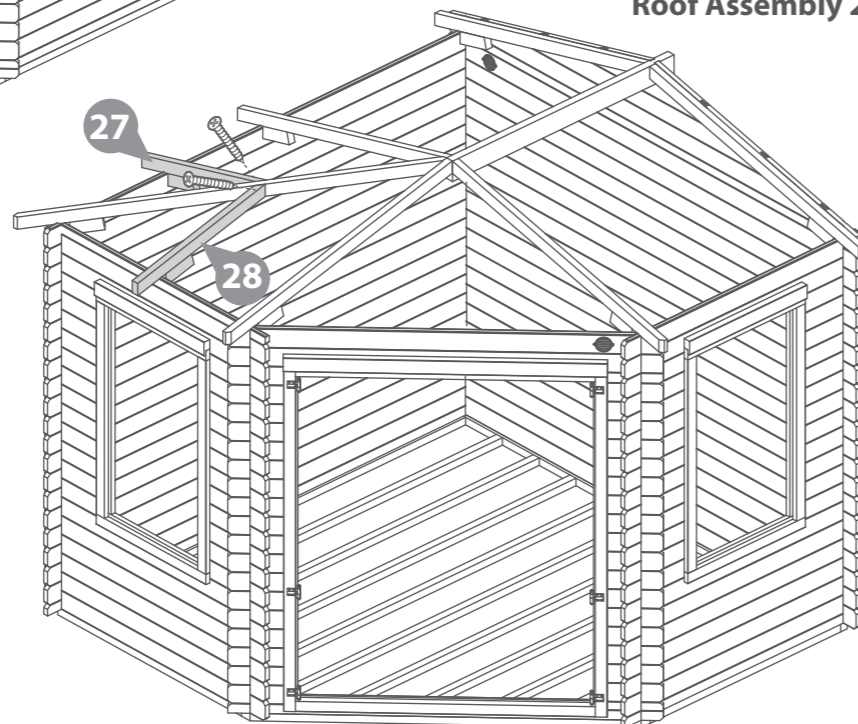

Please note: You can adjust the blocks attached to the roof truss' if necessary.

Step 26

**Parts needed - No. 22 QTY 1
No. 23 QTY 1
No. 24 QTY 1
No. 25 QTY 6**

Position the Finisher Boards (No. 22, 23, 24 & 25) around the building as shown, locating each board flush to the truss'. Ensure there is at least a 42mm gap between parts No. 25 on both sides of the log cabin.

Some adjustment may be required to ensure the roof structure rests correctly.

Secure each board in place by screwing through the board into the adjacent Roof Truss at an angle using 2x70mm screws per board, ensuring to stagger the screws to avoid them colliding.

14x70mm Screws
Important: Pre-drill before fixing screws.



Roof Assembly 1

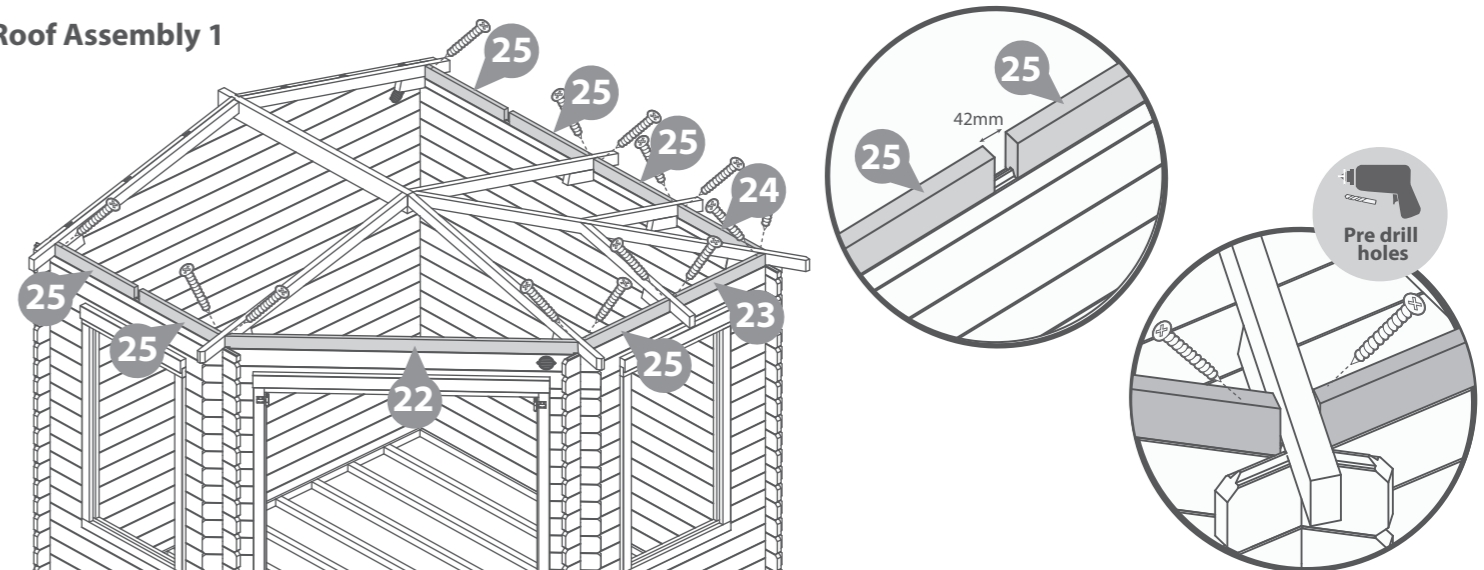

Roof Assembly 2

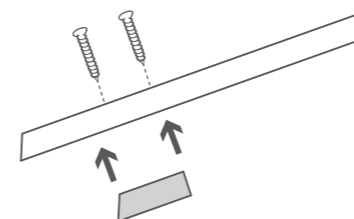
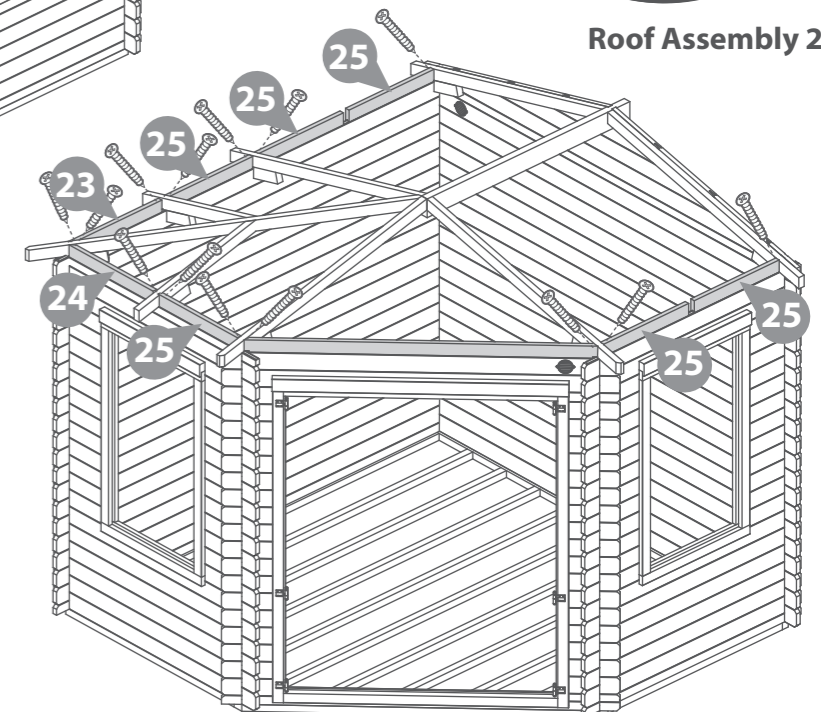

Please note: You can adjust the blocks attached to the roof truss' if necessary.

Step 27

Parts needed - No. 29 QTY 2

Locate the last two 'Roof Truss A' (**No. 29**) into the 42mm gaps between the finisher boards **No.25** on either side of the cabin, as shown in the illustration.

Some adjustment may be required to ensure the roof structure rests correctly.

Fix the Truss' (**No. 29**) in place by screwing through the Truss into the purlin at an angle using 1x90mm screw per Truss, as shown in the illustration.

Secure the boards (**No. 25**) in place by screwing through the board into the adjacent truss (**No. 29**) using 1x70mm screw per board, ensuring to stagger the screws to avoid them colliding.

4x70mm Screws
2x90mm Screws
Important: Pre-drill before fixing screws.



Roof Assembly 1

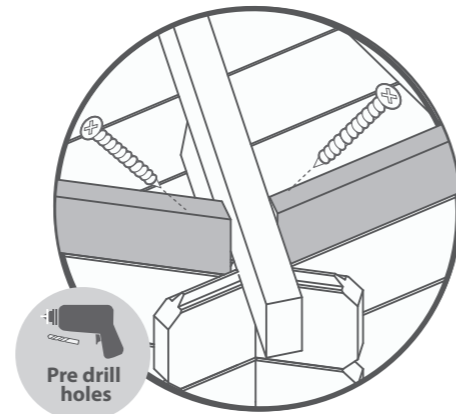
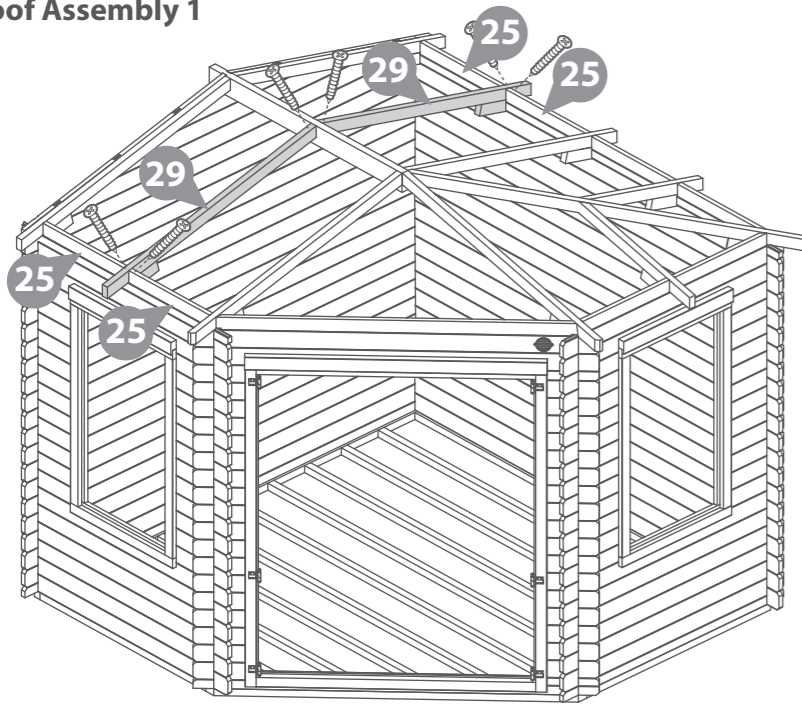

Roof Assembly 2

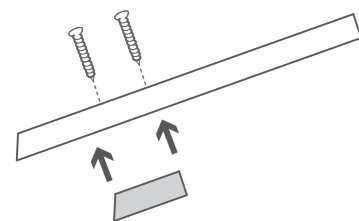
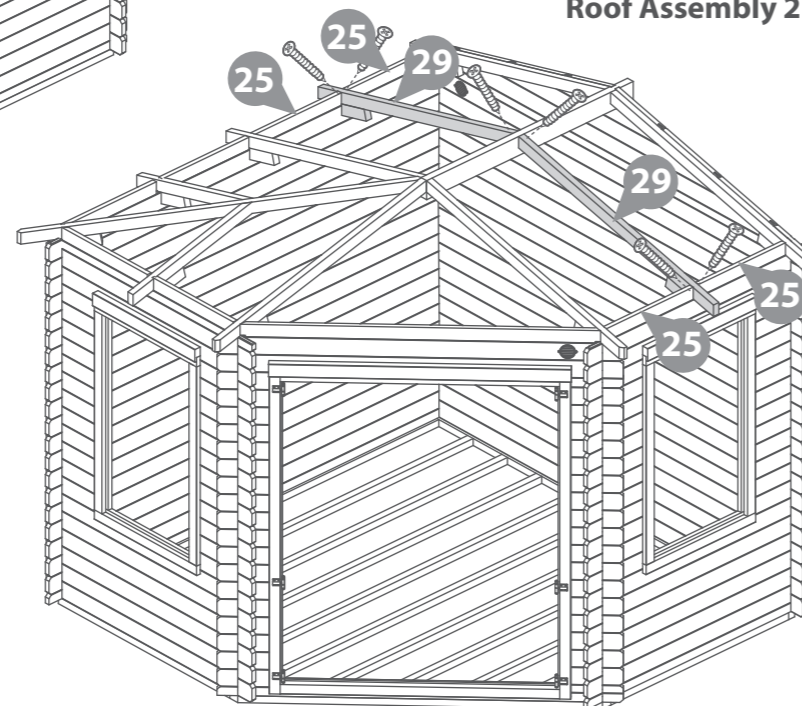

Please note: You can adjust the blocks attached to the roof truss' if necessary.

Step 28

You can now fix the assembled roof truss' and Roof Purlin to the log cabin, making sure the attached blocks sit inside the assembly. Some adjustment may be required to ensure the roof structure rests correctly.

Once in position, fix the truss' in place using 1x120mm screw per truss, screwing down through the truss into the board below, as shown in the diagram. Ensure to stagger screws to avoid them colliding.

Secure the Roof Purlin in place by screwing through the purlin at an angle into the gable using 2x70mm screws.

10x120mm Screws
2x70mm Screws
Important: Pre-drill before fixing screws.



Roof Assembly 1

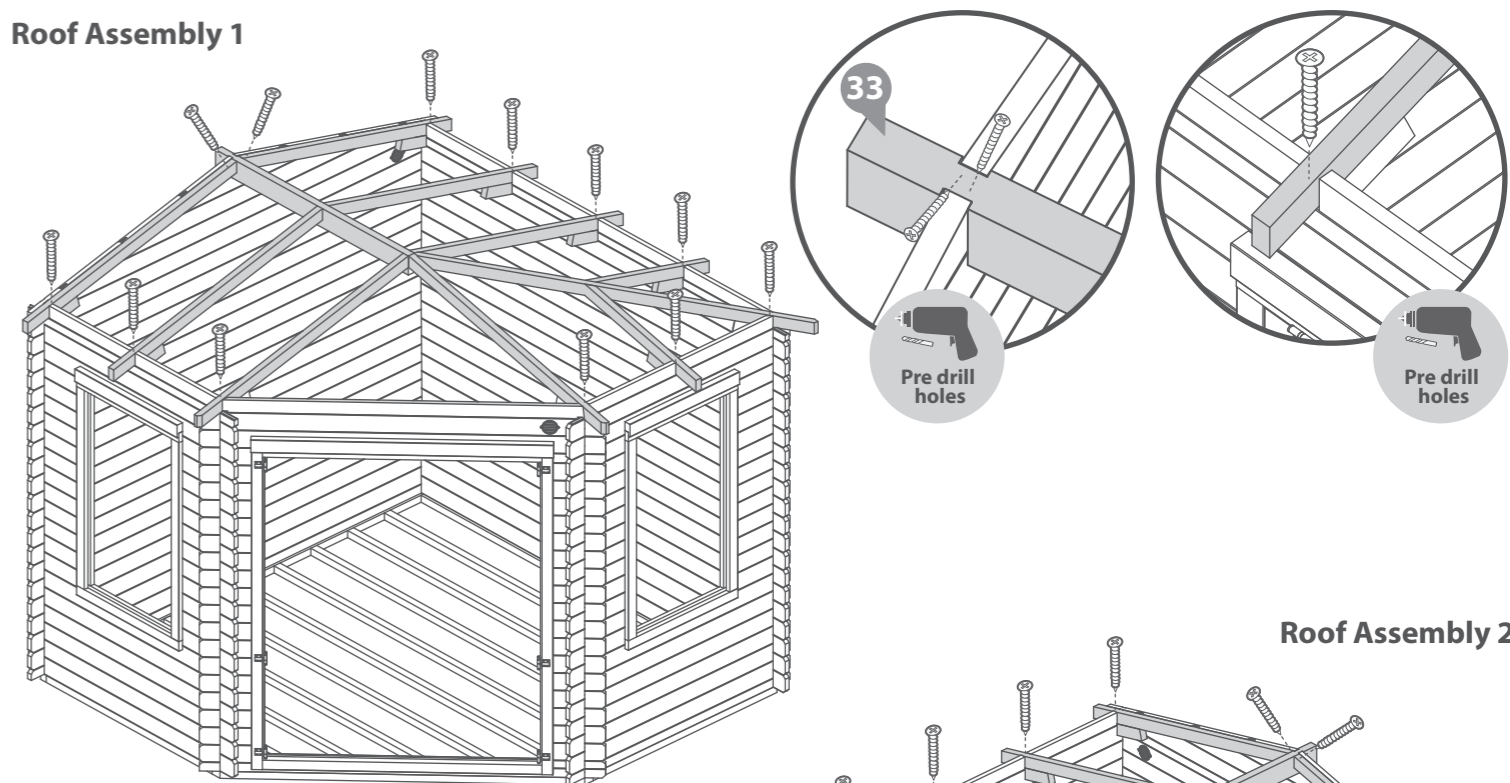

Roof Assembly 2

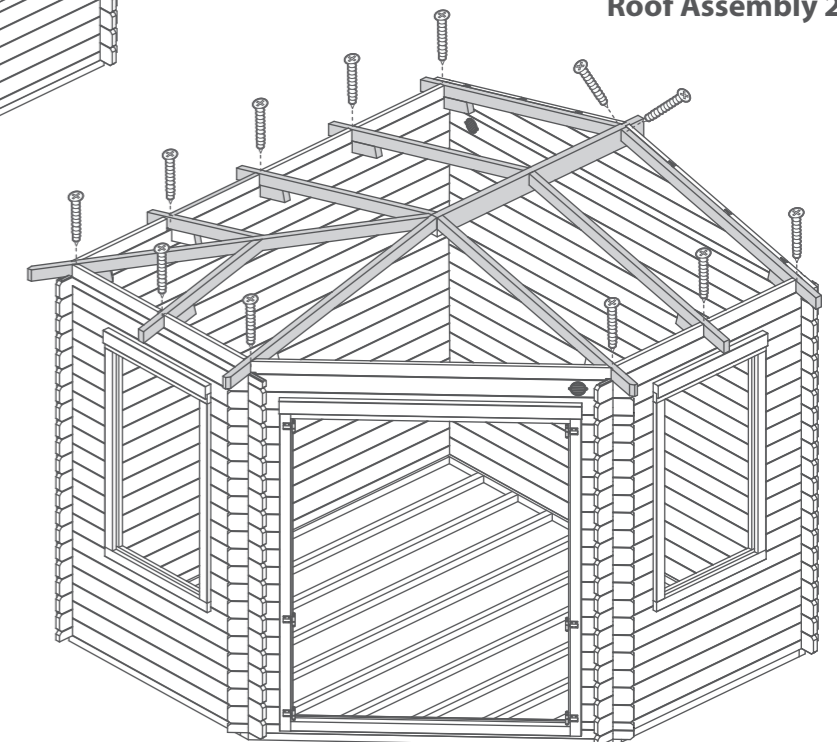

Step 29

**Parts needed - No. 34 QTY 1 Pack A
No. 35 QTY 2 Pack B
No. 36 QTY 2 Pack C**

***HINT: keep the individual roof board packs together to avoid mixing them up.**

Place the first board from each 'Roof Board Pack' (**No. 34, 35 & 36**) onto the roof assembly, working around the structure.

Once you are happy with the fit of the roof boards, fix them in place using 40mm screws, ensuring to screw through the roof board into the truss below.

28x40mm screws
Important: Pre-drill before fixing screws.

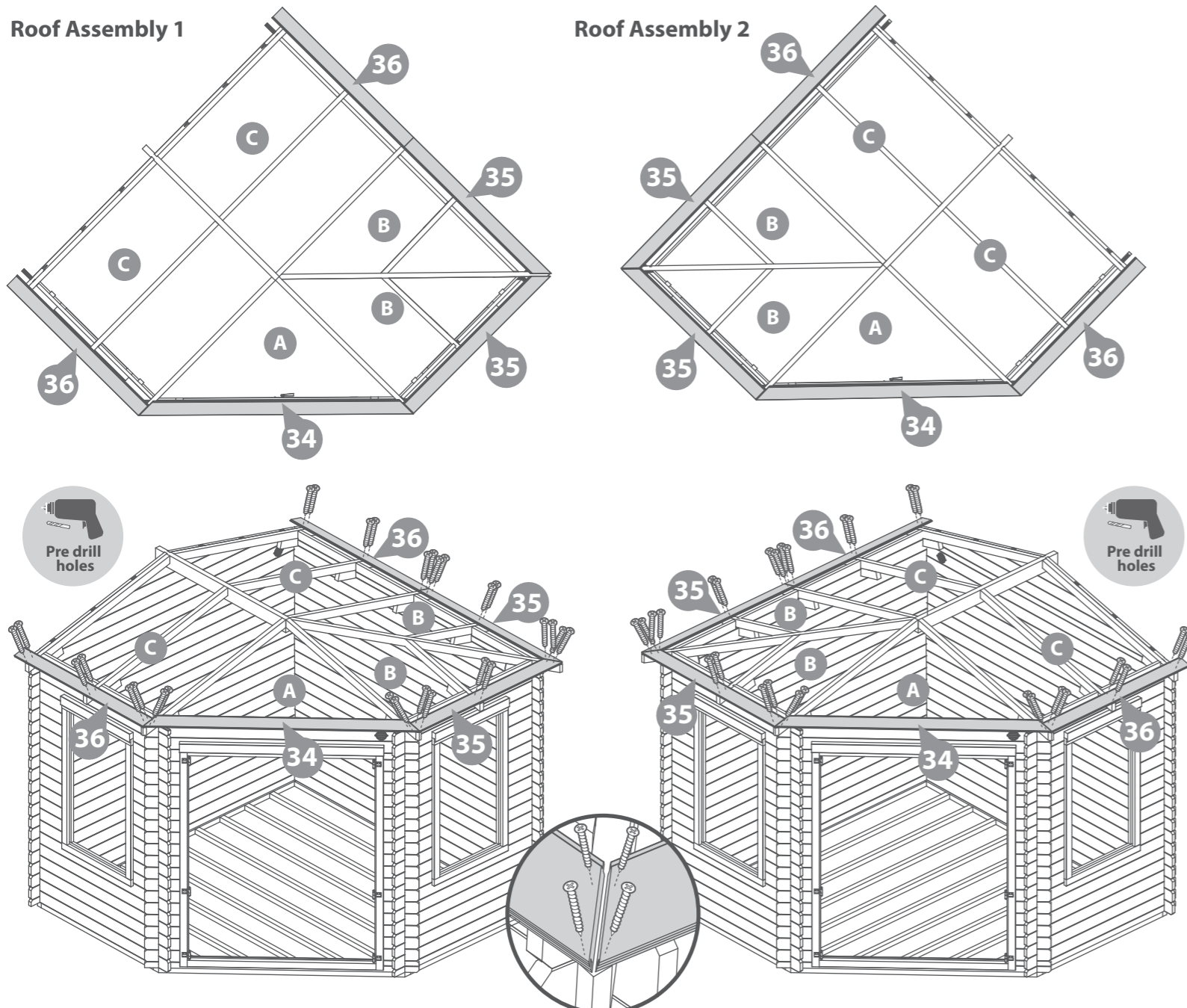

Step 30

**Parts needed - No. 34 QTY 1 Pack A
No. 35 QTY 2 Pack B
No. 36 QTY 2 Pack C
No. 55 QTY 5**

***HINT: keep the individual roof board packs together to avoid mixing them up.**

Continue arranging the Roof Board Packs (**No. 34, 35 & 36**) onto the roof assembly, working around the structure, building up each layer of roof boards one by one.

To ensure the roof boards are not laid too close together, use the spacers (**No.55**) provided to create a 2mm gap. Adjusting the spacing between the boards allows the wood to swell in damp weather.

Once you are happy with the fit of the roof boards, fix the 2nd, 3rd & 4th boards into place using 40mm screws, ensuring the screws fix through the roof board into the truss below.

Repeat this so you have four boards screwed down in total on each of the sides and three on the front.

80x40mm Screws
Important: Pre-drill before fixing screws.

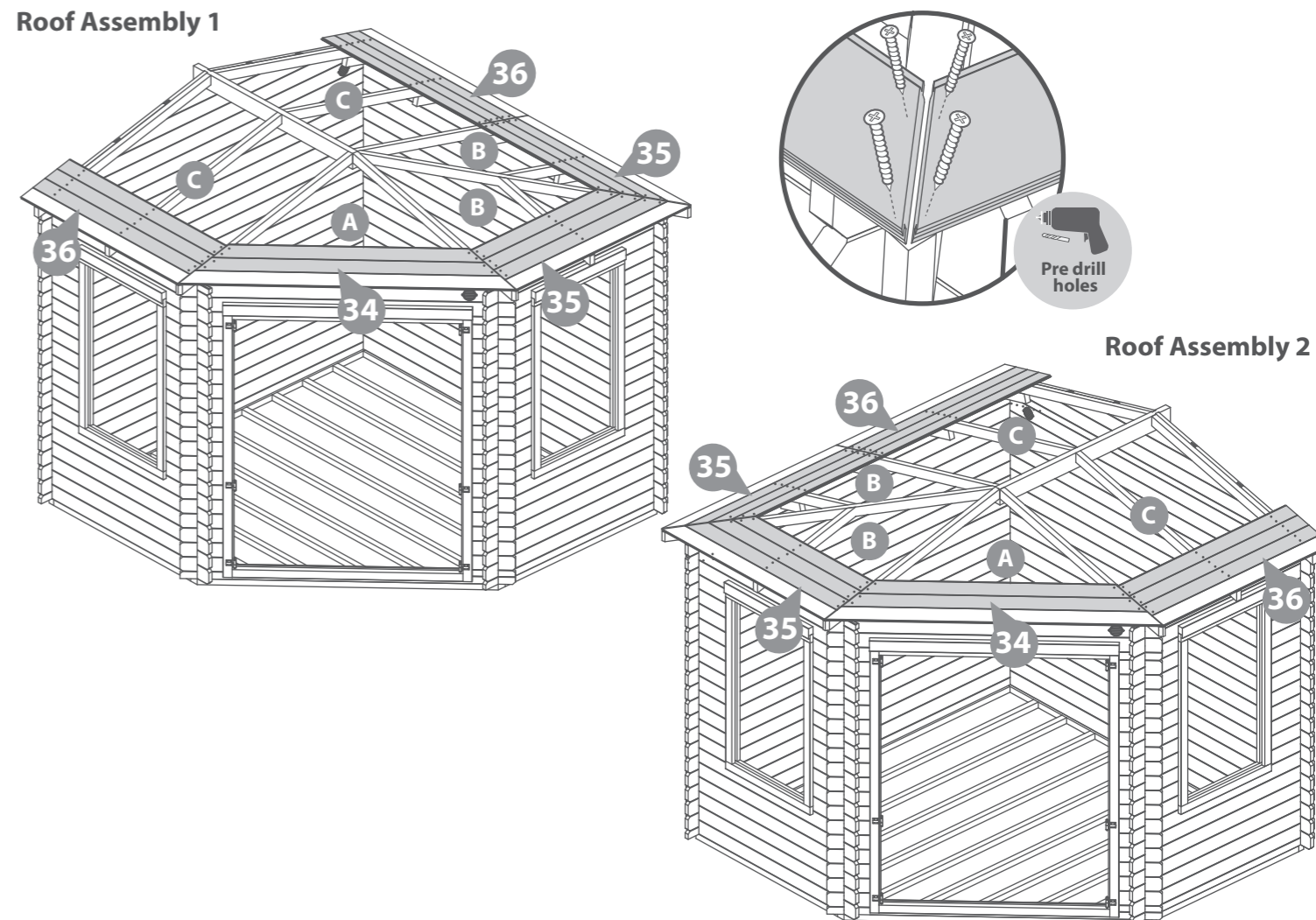
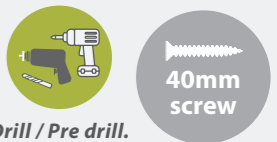

Step 31

**Parts needed - No. 34 QTY 1 Pack A
No. 35 QTY 2 Pack B
No. 36 QTY 2 Pack C
No. 55 QTY 5**

***HINT: keep the individual roof board packs together to avoid mixing them up.**

Continue arranging the Roof Board Packs (**No. 34, 35 & 36**) onto the roof assembly, working around the structure, building up each layer of roof boards one by one.

To ensure the roof boards are not laid too close together, use the spacers (**No.55**) provided to create a 2mm gap. Adjusting the spacing between the boards allows the wood to swell in damp weather.

Once you are happy with the fit of the roof boards, fix the 5th, 6th & 7th boards into place using 40mm screws, ensuring the screws fix through the roof board into the truss below.

Repeat this so you have seven boards high screwed down in total on each of the sides and five on the front.

80x40mm Screws
Important: Pre-drill before fixing screws.



Roof Assembly 1

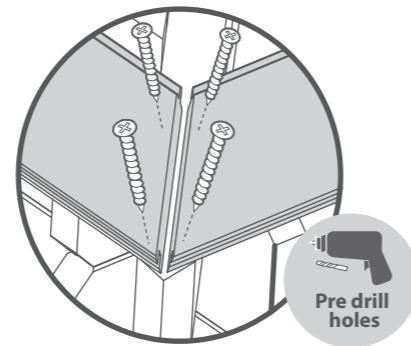
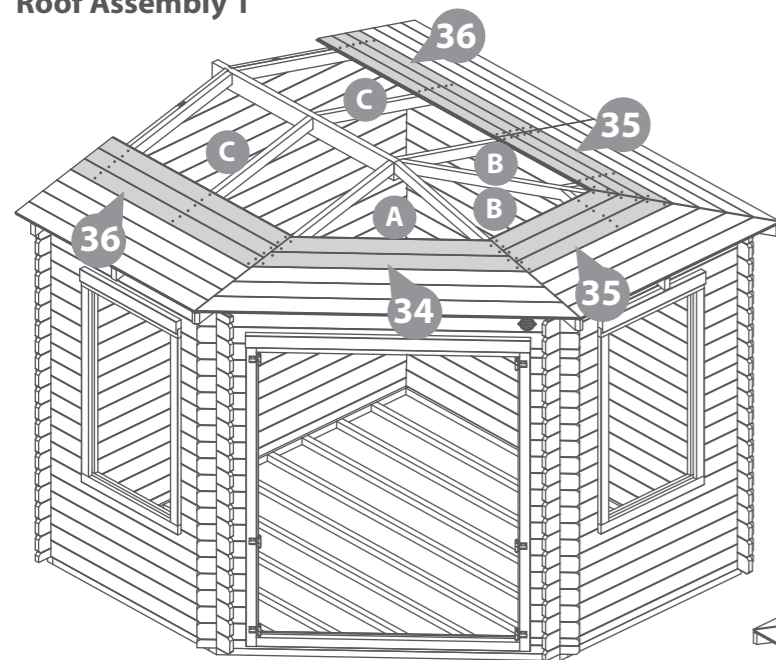

Roof Assembly 2

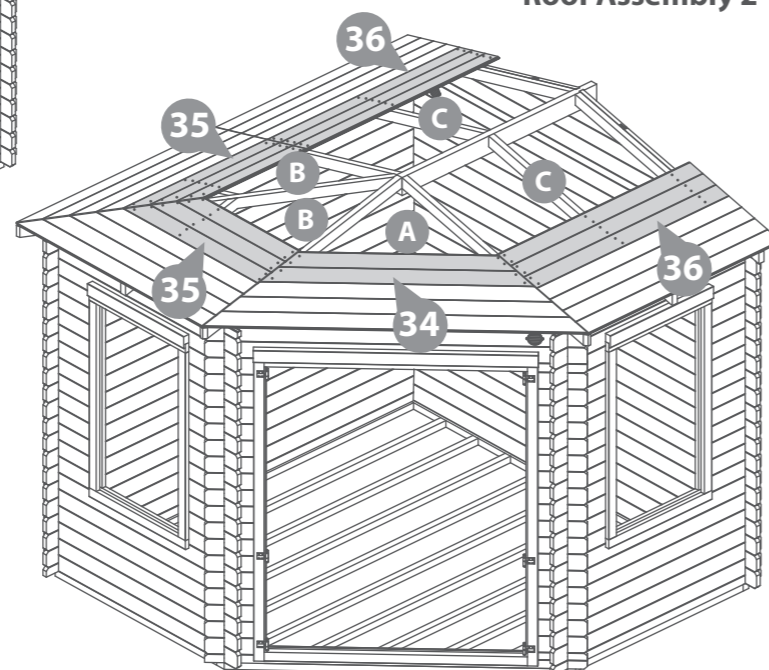

Step 32

**Parts needed - No. 34 QTY 1 Pack A
No. 35 QTY 2 Pack B
No. 36 QTY 2 Pack C
No. 55 QTY 5**

***HINT: keep the individual roof board packs together to avoid mixing them up.**

Continue arranging the Roof Board Packs (**No. 34, 35 & 36**) onto the roof assembly, working around the structure, building up each layer of roof boards one by one.

To ensure the roof boards are not laid too close together, use the spacers (**No.55**) provided to create a 2mm gap. Adjusting the spacing between the boards allows the wood to swell in damp weather.

Once you are happy with the fit of the roof boards, fix the 8th, 9th & 10th boards into place using 40mm screws, ensuring the screws fix through the roof board into the truss below.

Repeat this so you have 10 boards high screwed down in total on each of the sides and seven on the front.

68x40mm Screws
Important: Pre-drill before fixing screws.

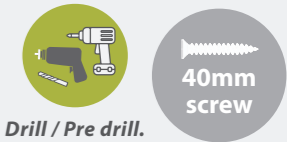

Roof Assembly 1

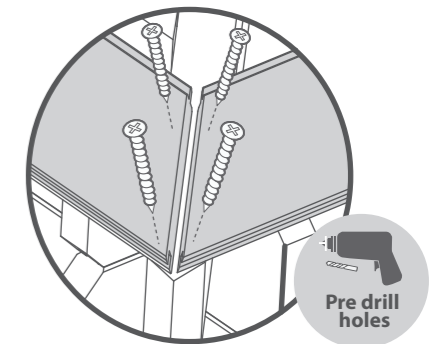
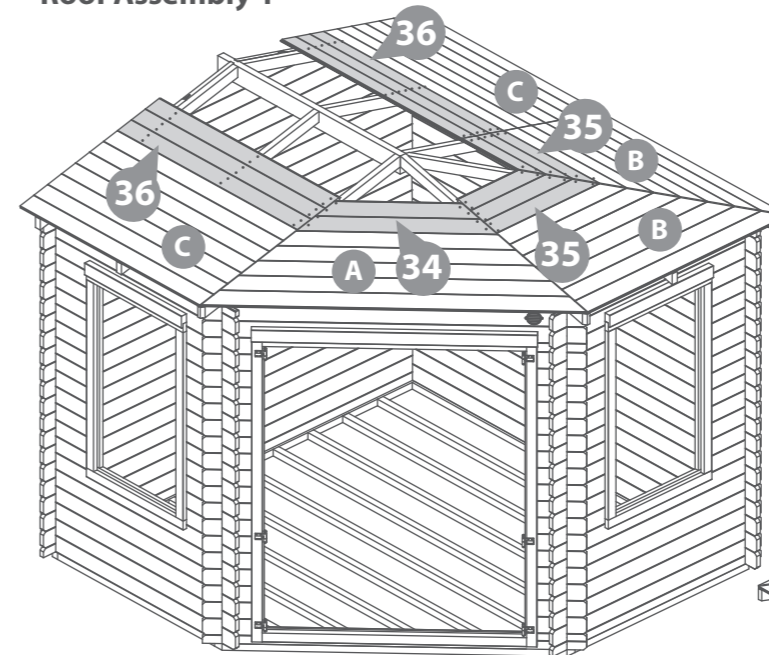

Roof Assembly 2

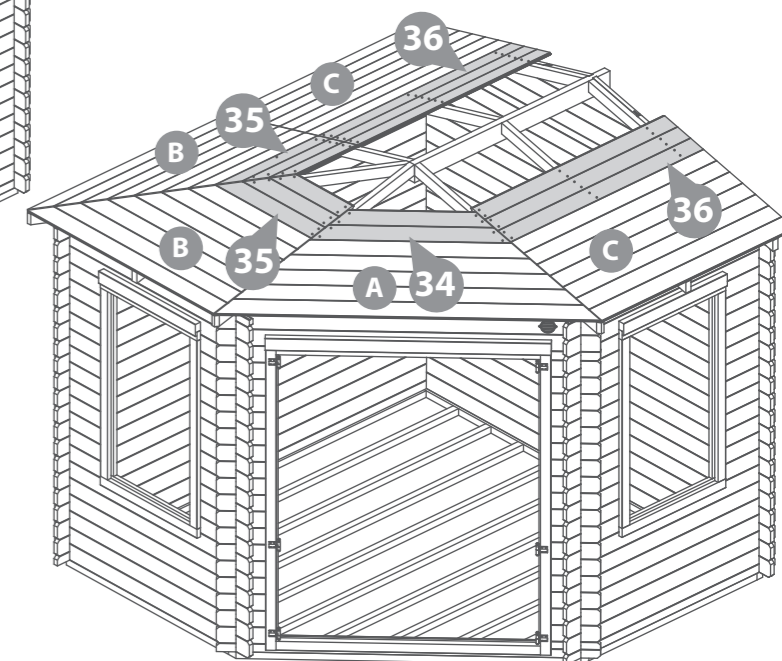

Step 33

- Parts needed - No. 34 QTY 1 Pack A**
No. 35 QTY 2 Pack B
No. 36 QTY 2 Pack C
No. 55 QTY 5

***HINT: keep the individual roof board packs together to avoid mixing them up.**

Continue arranging the Roof Board Packs (**No. 34, 35 & 36**) onto the roof assembly, working around the structure, building up each layer of roof boards one by one. Use the spacers (**No.55**) provided to create a 2mm gap.

The last two boards from Pack C (**No. 36**) will overhang at the top. Using a pencil and a straight edge, mark out the excess with a line as a guide. Saw along the mark, remove the excess and then place the cut down boards back onto the roof.

Once you are happy with the fit of the roof boards, fix the remaining boards into place using 40mm screws, ensuring the screws fix through the roof board into the truss below.

Repeat this so you have the rest of the boards high screwed down on each of the five sides.

104x40mm Screws

Important: Pre-drill before fixing screws.



Roof Assembly 1

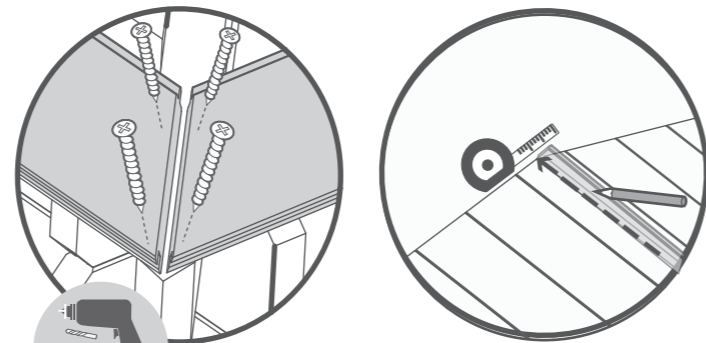
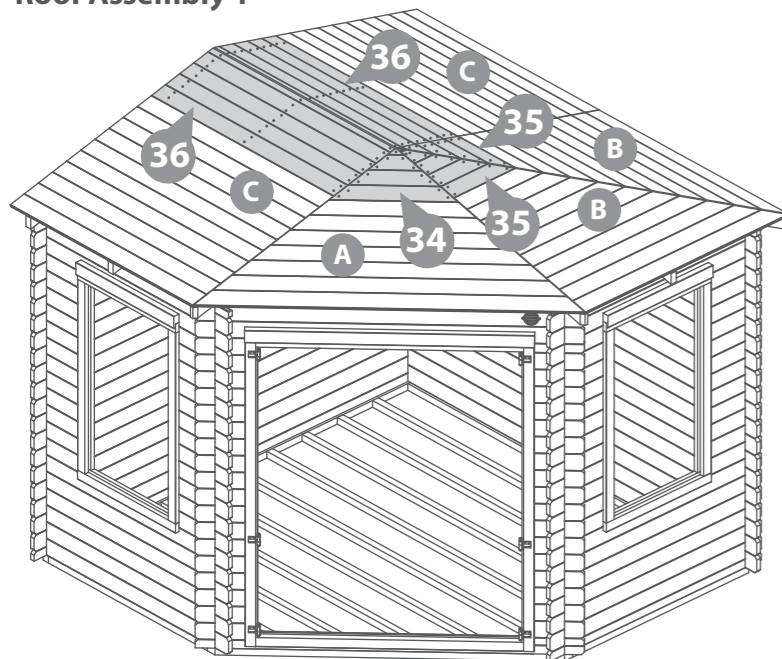

Roof Assembly 2

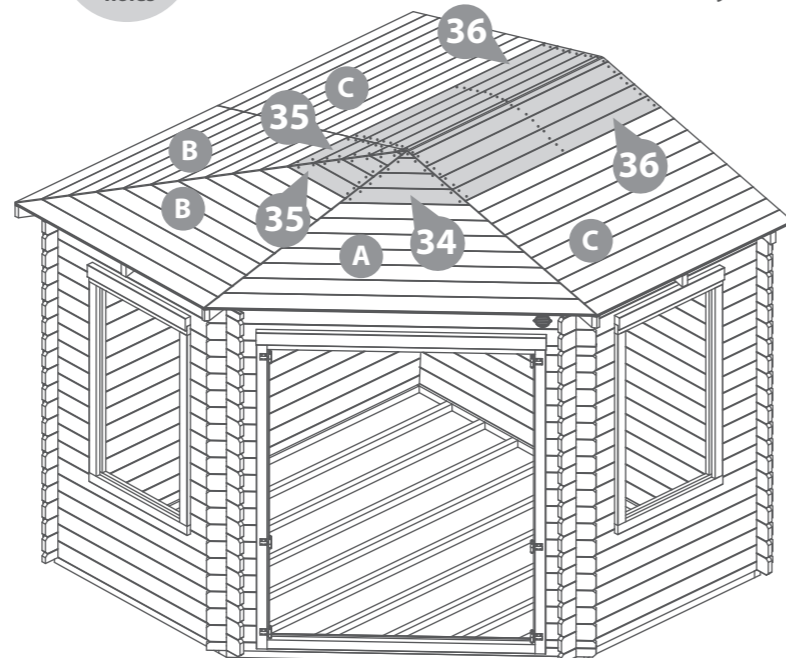

Step 34

- Parts Needed - No. 68 QTY 2**

Once the Roof is secured, open the window hinges and re-position the Window (**No. 68**) onto the hinges (as previously done in step 12) and fix in place using the same 3x30mm screws per hinge.

Ensure the window is able to open and close freely without getting stuck on the frame.

Use this method to fix both windows into the frames.

****Please note: This image is for illustrative purposes and may differ from the roof assembly you have constructed, however the process of fitting the windows is the same.**

Important: Pre-drill before fixing screws.

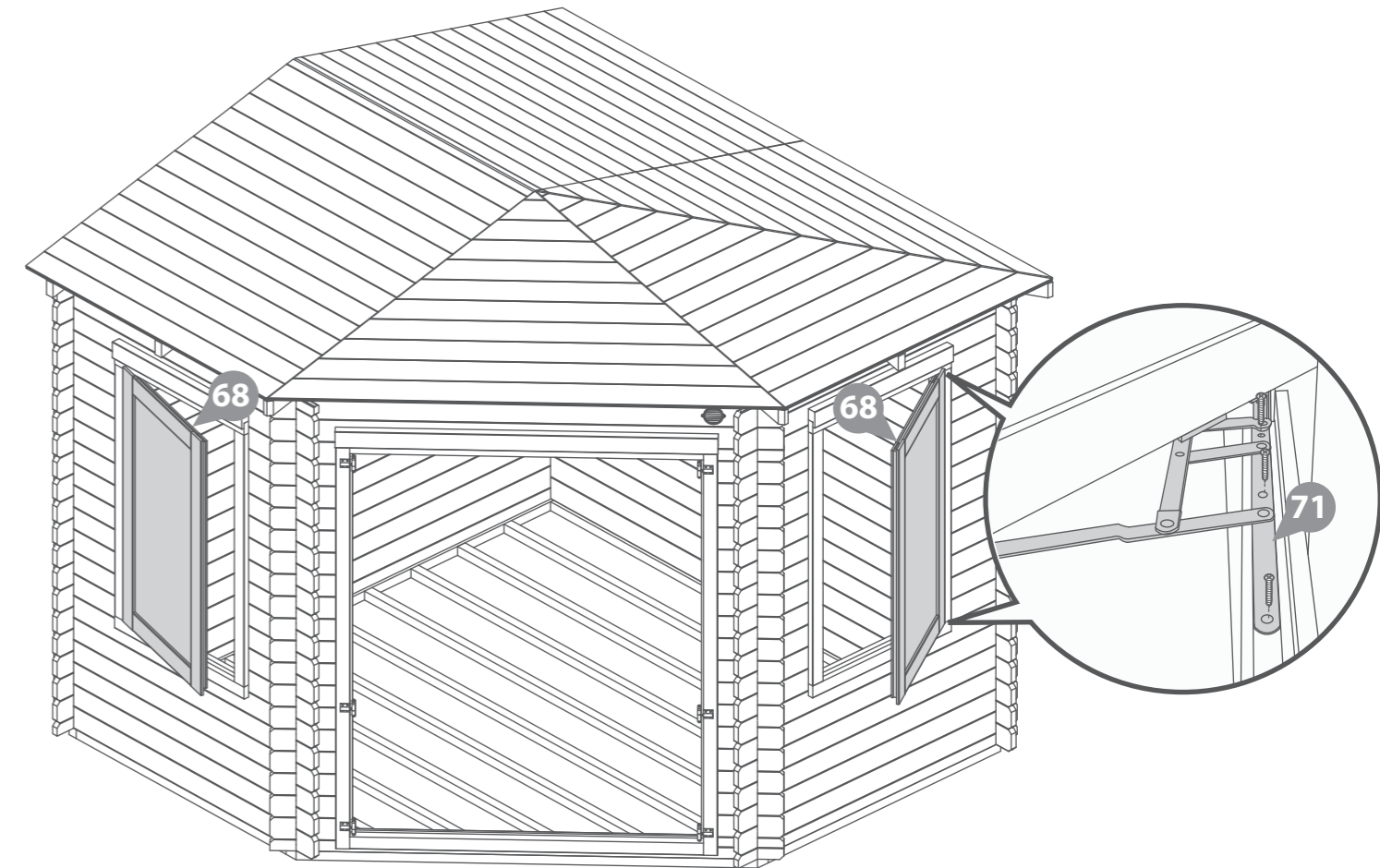
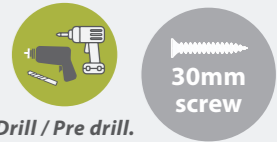

Step 35

Parts Needed - No. 72 QTY 2

With the window (No.68) shut tight, from the inside locate the Window Handle (No.72) onto the window and the window casement pin onto the inside of the window frame, as shown.

Ensuring the two parts locate together and shut correctly, fix the handle in place using 2x30mm screws, and secure the pin in place using 2x30mm screws.

Check that when locked, the window is as tight to the frame as possible. This will ensure a tight seal when the window is shut.

Use this method to locate and fix a handle to both windows.

8x30mm screws.

Important: Pre-drill before fixing screws.



Drill / Pre drill.

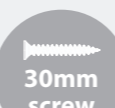

30mm screw

Internal view of window

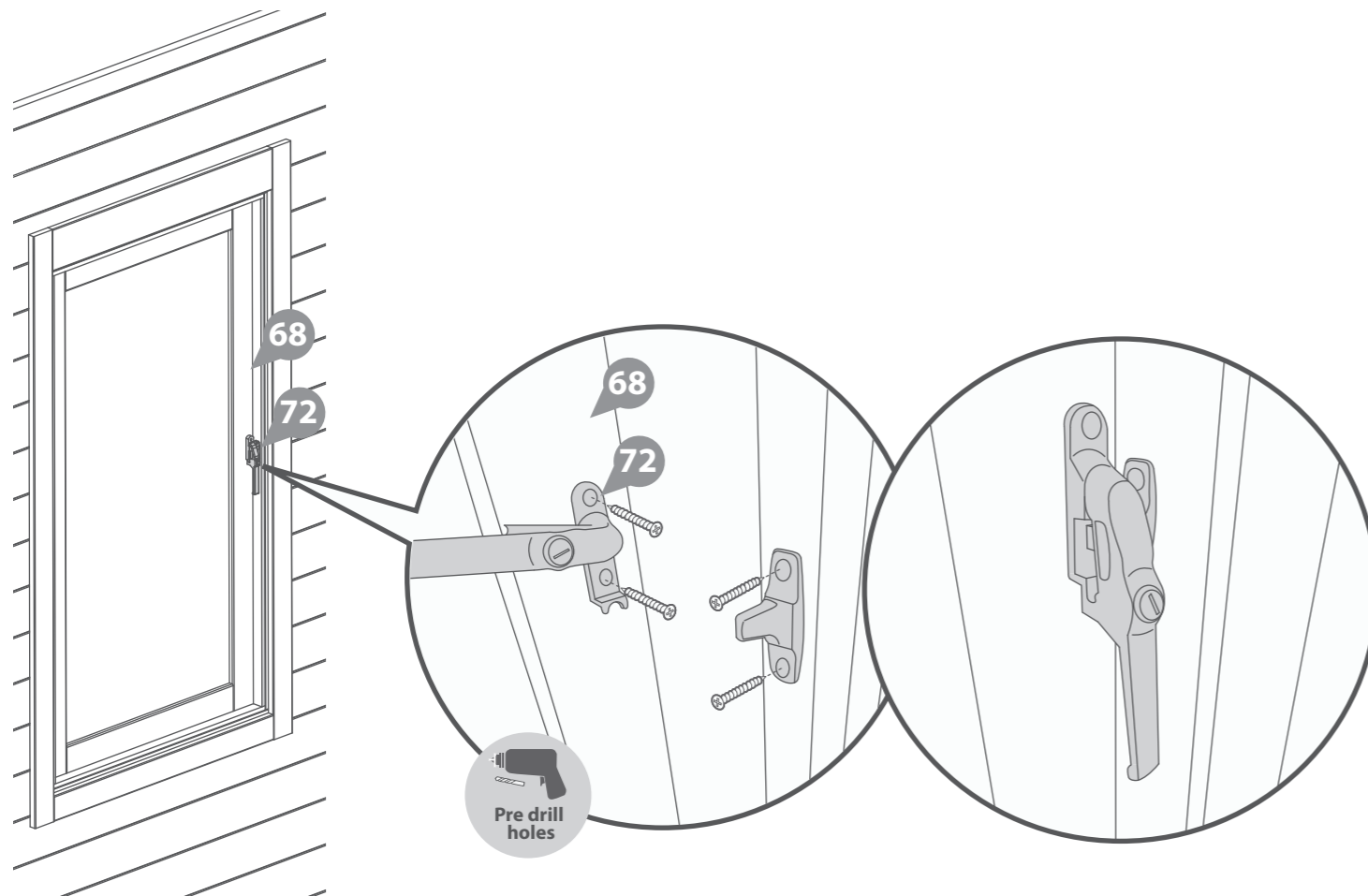

Step 36

Lift each door onto the already existing hooks on the door frame, ensuring the hook and bands connect.

***Some adjustment may be required to align properly. To adjust and align your doors:**

1. Lift up the doors to separate the two parts of the hinge.
2. Turn the rotating barrel (No.64a) in / out to move the position of the doors either in or away from each other.
3. You can then place the door(s) back on to the hinge and check whether they require more / less adjustments, if further adjustments are required repeat number 2.

****Please note:** This image is for illustrative purposes and may differ from the roof assembly you have constructed, however the process of fitting the doors is the same.

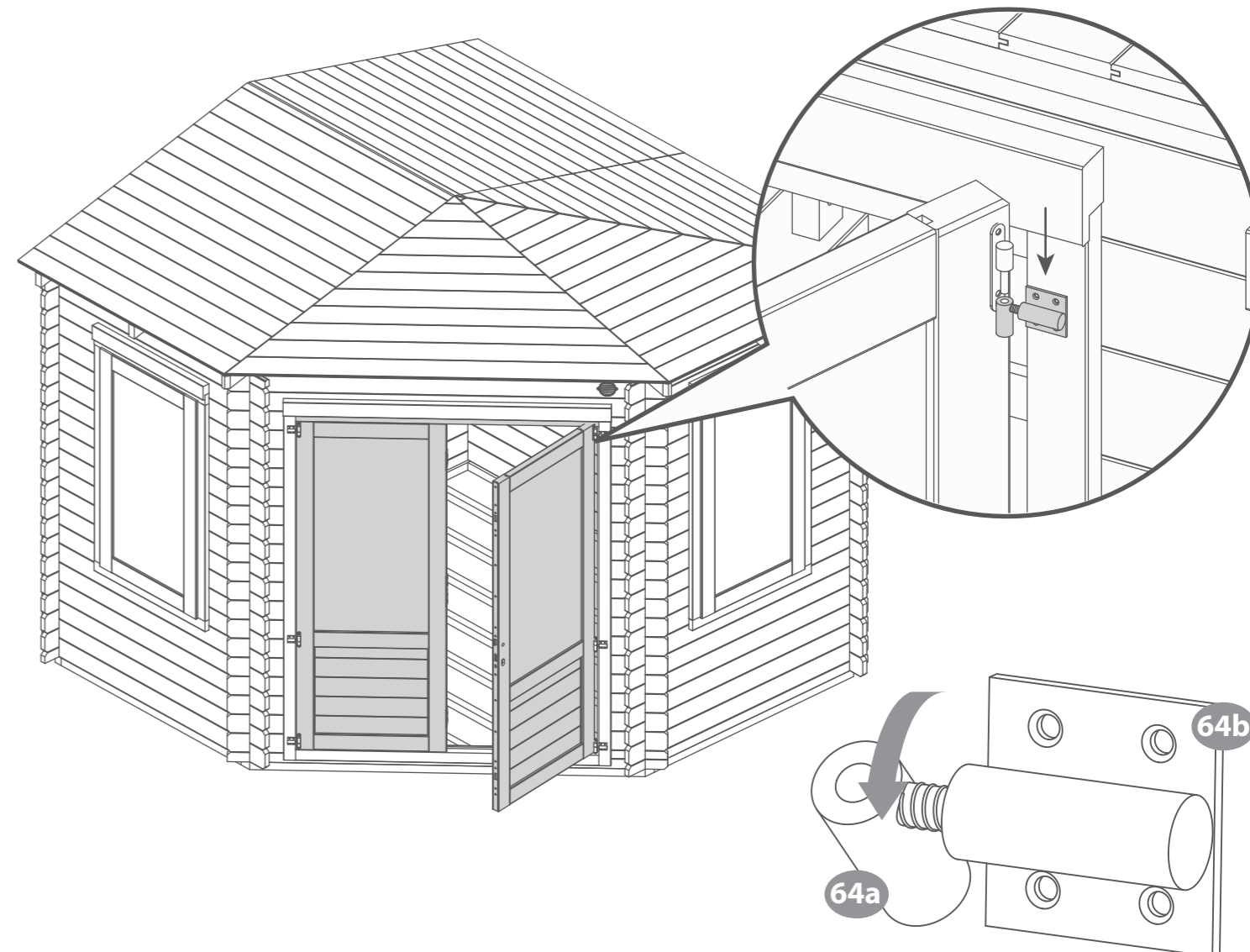

Adjusting the door hinges

Step 39

Parts Needed - No. 62 QTY 1

No. 67 QTY 2

- a** Attach the Door Strip (**No. 62**) to the back of the Secondary Door (**No. 57**) using 4x40mm screws, as shown.
- b** Once fixed, place the Tower Bolts (**No. 67**) roughly into position at the top/bottom of the door strip. With a pencil mark around the bolt.

After marking the bolt onto the frame, drill a hole for the barrel bolt to locate into.

- c** Following the hole being drilled, place the tower bolts into position and secure using the screws provided.

4x40mm Screws

Important: Pre-drill before fixing screws.

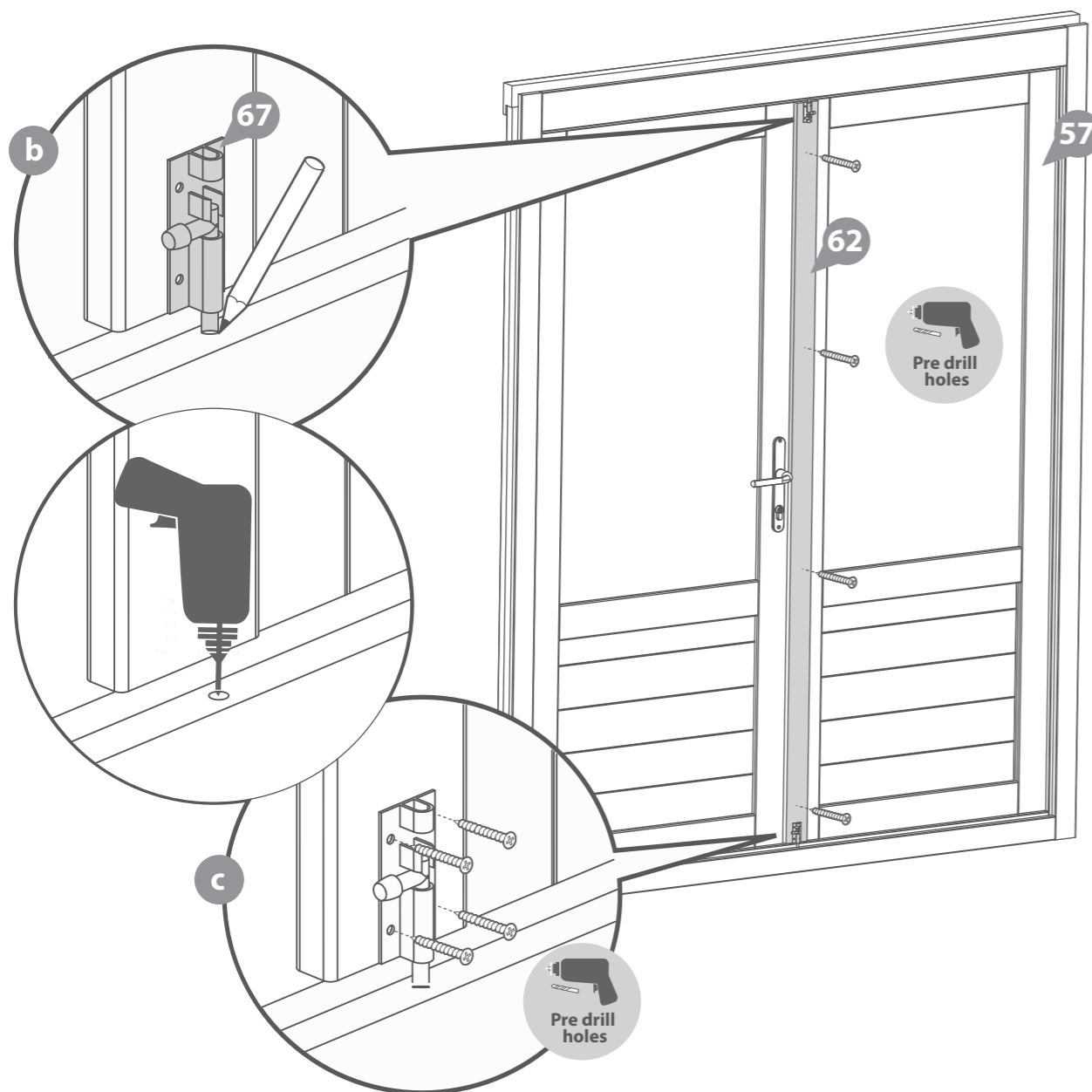

Step 40

Parts Needed - No. 50

- a** Place the first floor board (**No. 50**) inside the building flush to the log board on one side. Continue adding the floor boards (*internally*) making sure to interlock each individual board.

***Do NOT secure the boards until the last board has been measured and cut.**

- b** Once a full board can no longer fit, measure the gap between the bottom of the tongue (*on the last board placed*) and the log board. Ensure to measure at multiple points along the board for added accuracy.

Using a straight edge, mark out the measurement onto the last floor board (**No. 50**), saw along the length and remove the excess. *Mark the final board 2mm under the measurement; This will allow the timber to expand and contract correctly.*

Once all the floor boards are in position, secure each board into position using 9x40mm screws per board.

*****Please Note:** Ensure to screw through each of the floor boards into the floor bearers.

234x40mm Screws

Important: Pre-drill before fixing screws.

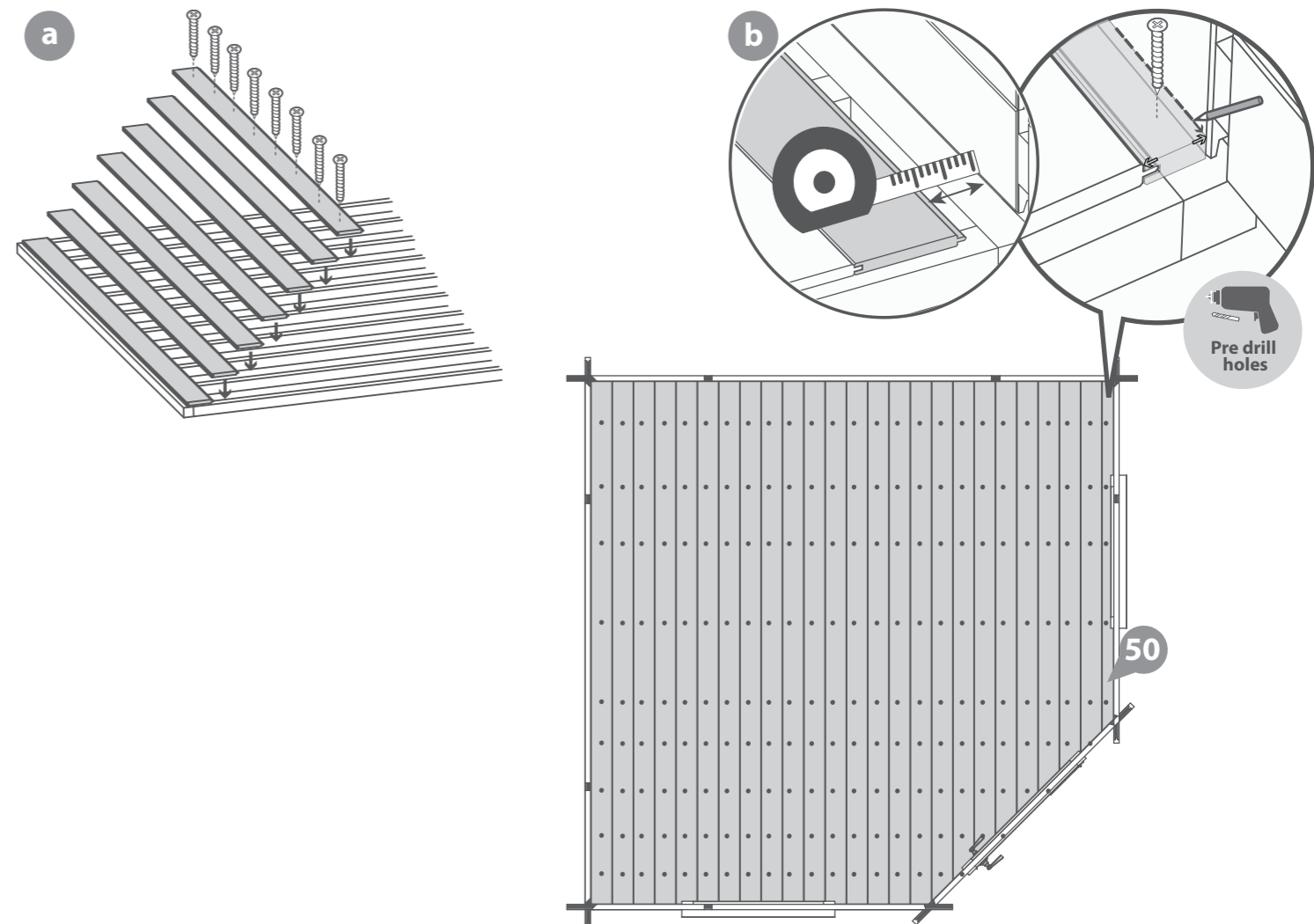

Step 41

Parts needed - No. 51 QTY 5

Inside the building place the closure trim (**No. 51**) against the boarding and align with the roof as shown in the illustration.

***Measure and cut the closure trims to fit the internal space.**

Once in position fix each trim into place by pre drilling a pilot hole and using 6x30mm screws per trim, equally spacing them along the face of the board.

30x30mm Screws

Important: Pre-drill before fixing screws.

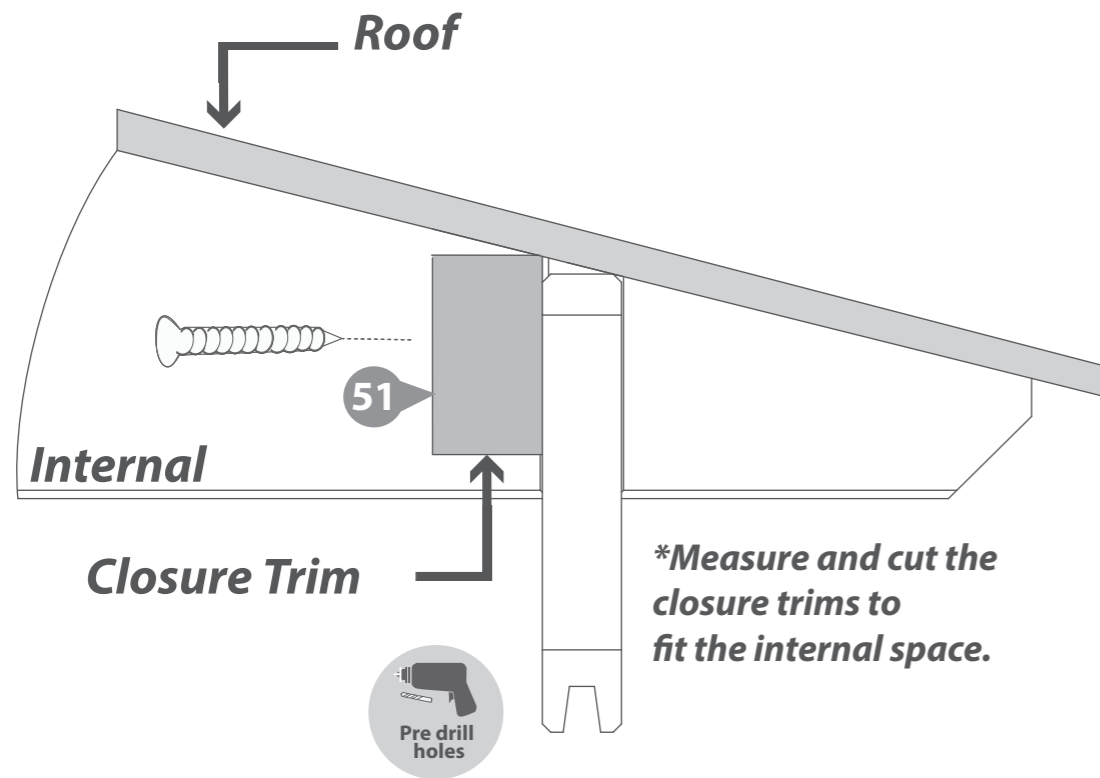

Step 42

Parts needed - No. 51 QTY 5

Once the floor has been laid, arrange the closure trim (**No. 51**) around the outside edge of the floor (**internally**), measure and cut down accordingly to best match the internal space.

Secure each trim section into place using 6x30mm screws spaced equally along the board, as shown in the illustration.

***Do NOT fix the closure trim to the floor boards.**

30x30mm Screws

Important: Pre-drill before fixing screws.

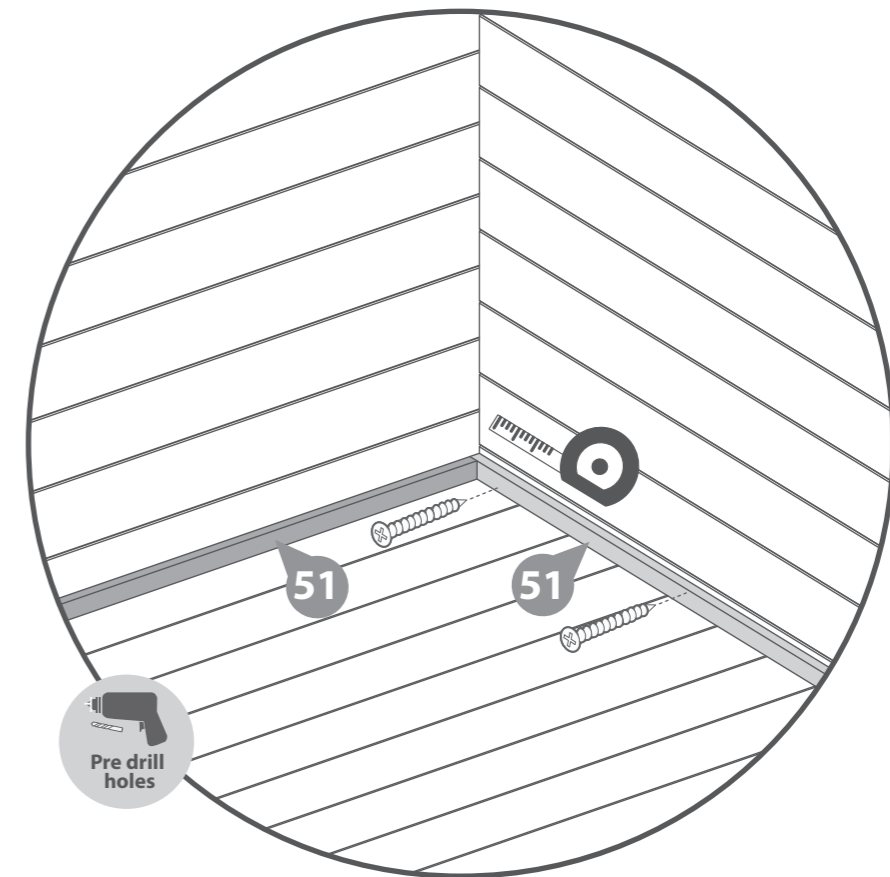

Step 43

Parts needed - No. 54

Measure and cut the felt (No.54) into eight sheets using the dimensions given below:

- 1 - 1600mm (L) x 1000mm (W)
- 2 - 2300mm (L) x 1000mm (W)
- 3 - 1660mm (L) x 1000mm (W)
- 4 - 3200mm (L) x 1000mm (W)
- 5 - 1600mm (L) x 1000mm (W)
- 6 - 820mm (L) x 1000mm (W)
- 7 - 700mm (L) x 1000mm (W)
- 8 - 2300mm (L) x 1000mm (W)

Lay the first piece of felt (1- 1600mm X 1000mm) onto the roof as shown (1) and cut down to the individual shape of the roof.

Continue this method to lay and shape each piece of felt (2-8) in the order as shown.

Ensure each sheet overlaps by 100mm and that the felt overhangs the edge of the roof by at least 50mm on each side.

Secure the felt in place using felt tacks spaced out at 100mm intervals.

250 x Felt Tacks

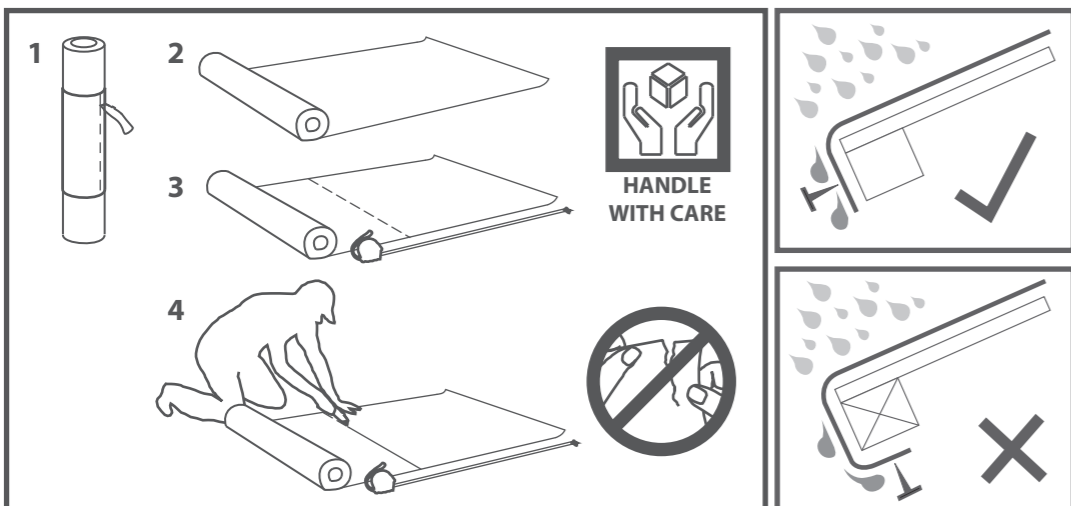
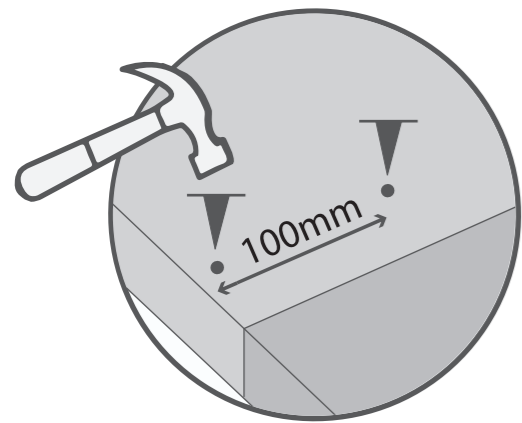
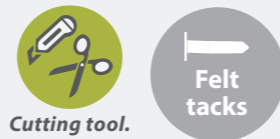

Roof Assembly 1

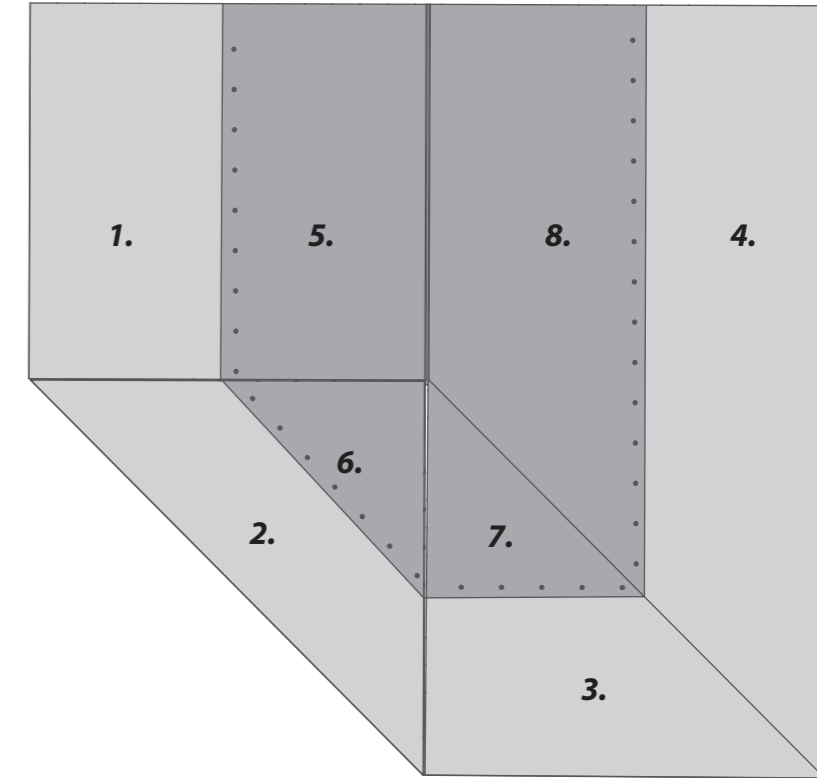
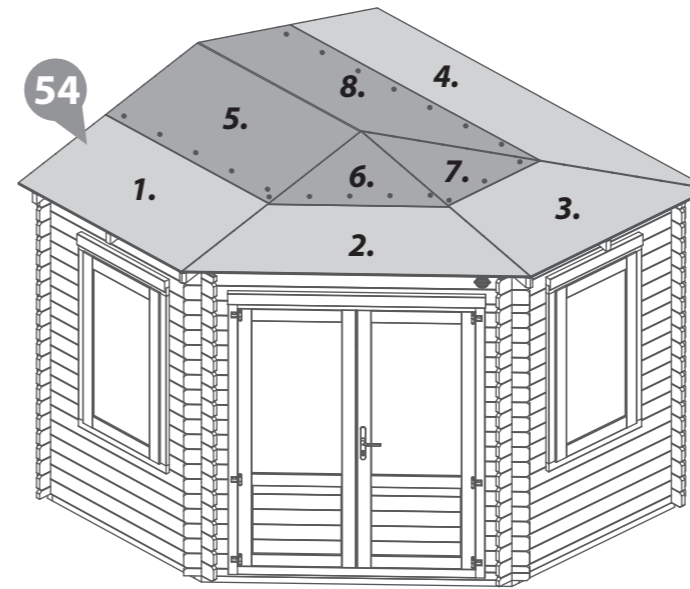

Roof Assembly 2

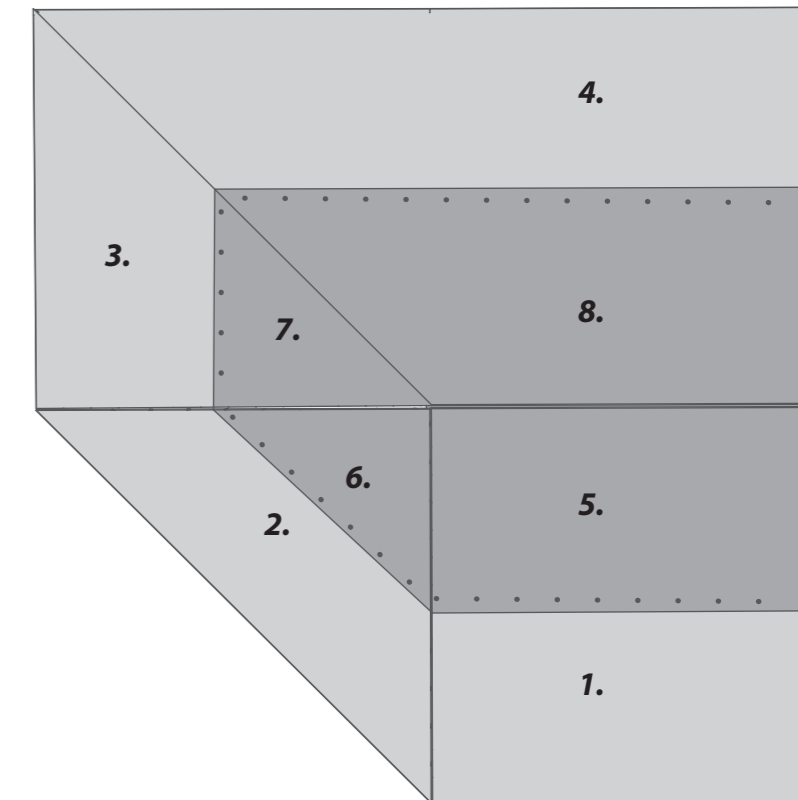
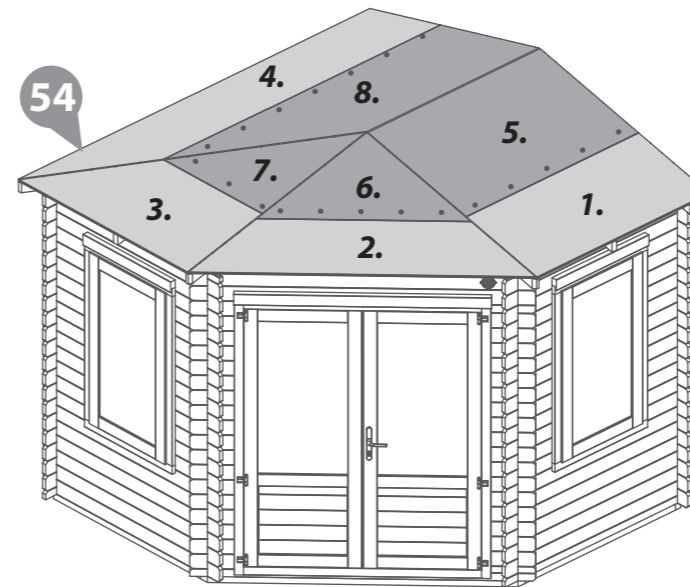

Step 44

Parts needed - No. 54

Measure and cut the remaining felt (No.54) into four strips using the dimensions given below:

- 1 - 1600mm (L) x 200mm (W)
- 2 - 2340mm (L) x 200mm (W)
- 3 - 1700mm (L) x 200mm (W)
- 4 - 1710mm (L) x 200mm (W)

Lay the first strip (1- 1600mm X 200mm) onto the roof as shown (1), ensuring it is overlapping the previously placed sheets.

Continue this method to lay each of the felt strips (2-4) onto the roof.

Secure along the outer edge of each felt section using felt tacks spaced out at 100mm intervals.

150 x Felt Tacks



Cutting tool.



Felt tacks

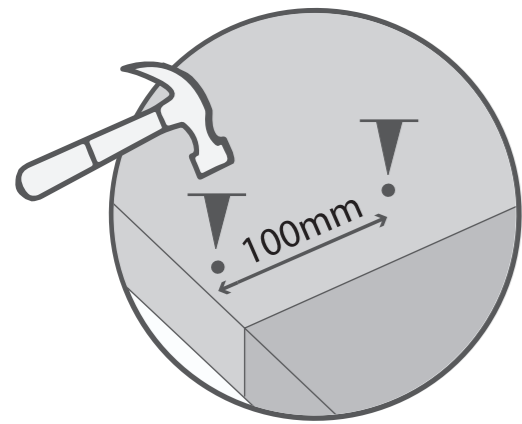

Roof Assembly 1

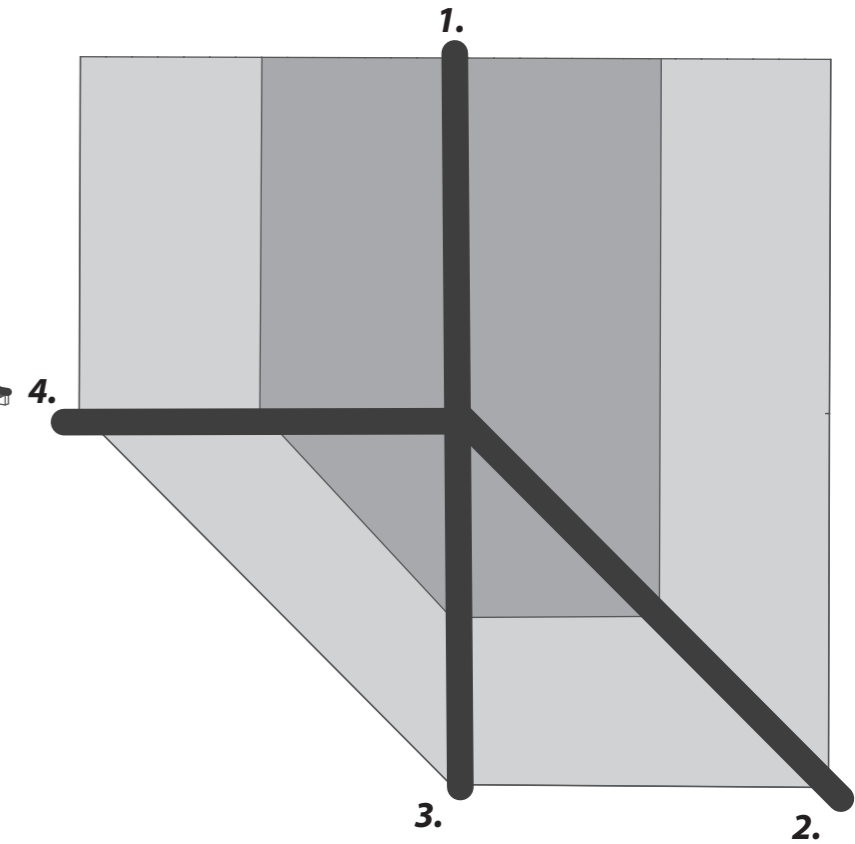
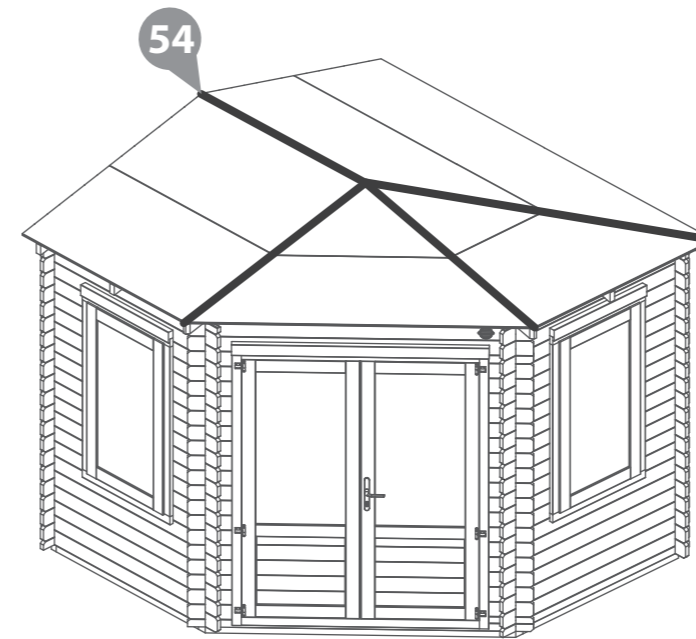

Roof Assembly 2

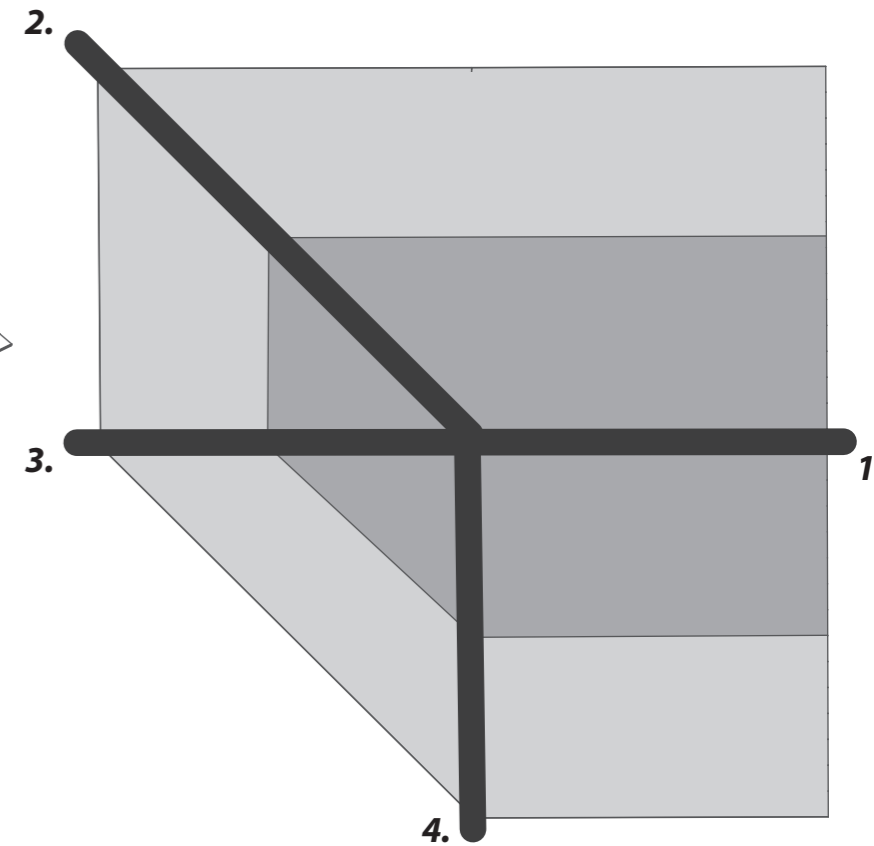
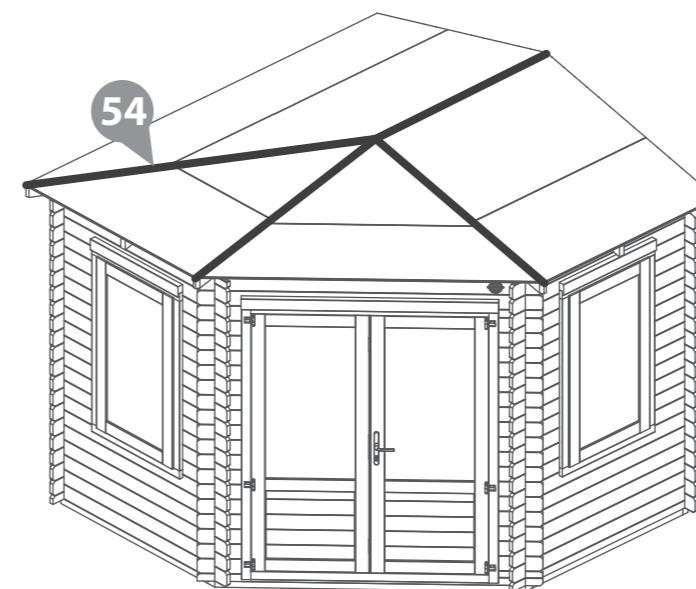

1

2

3

4

HANDLE WITH CARE

Step 45

- Parts Needed - No. 46 QTY 1**
No. 47 QTY 1
No. 48 QTY 2
No. 49 QTY 2

a Position the Fascias (**No. 46 & 49**) to the back sides of the log cabin (ensuring to trap the felt in between the fascias) securing in place by screwing through the Fascia into the Purlin, Roof Truss or Log board behind using 8x40mm screws per Fascia.

Once in place mark the excess Fascia with a pencil and trim the Fascias to follow the shape of the building as shown in the illustration.

b Locate the Fascias (**No. 47 & 48**) to the front sides of the log cabin (ensuring to trap the felt in between the fascias) and secure (**No. 48**) in place using 6x40mm screws per fascia, and (**No. 47**) in place using 4x40mm screws, screwing through the Fascia in to the Roof Truss behind.

Once in place, repeat the above method to trim the fascias to follow the shape of the building.

Ensure the fascias sit level or lower than the felt to allow water to run off.

****Please note:** This image is for illustrative purposes and may differ from the roof assembly you have constructed, however the process of fitting the fascias is the same.

40x40mm Screws
Important: Pre-drill before fixing screws.

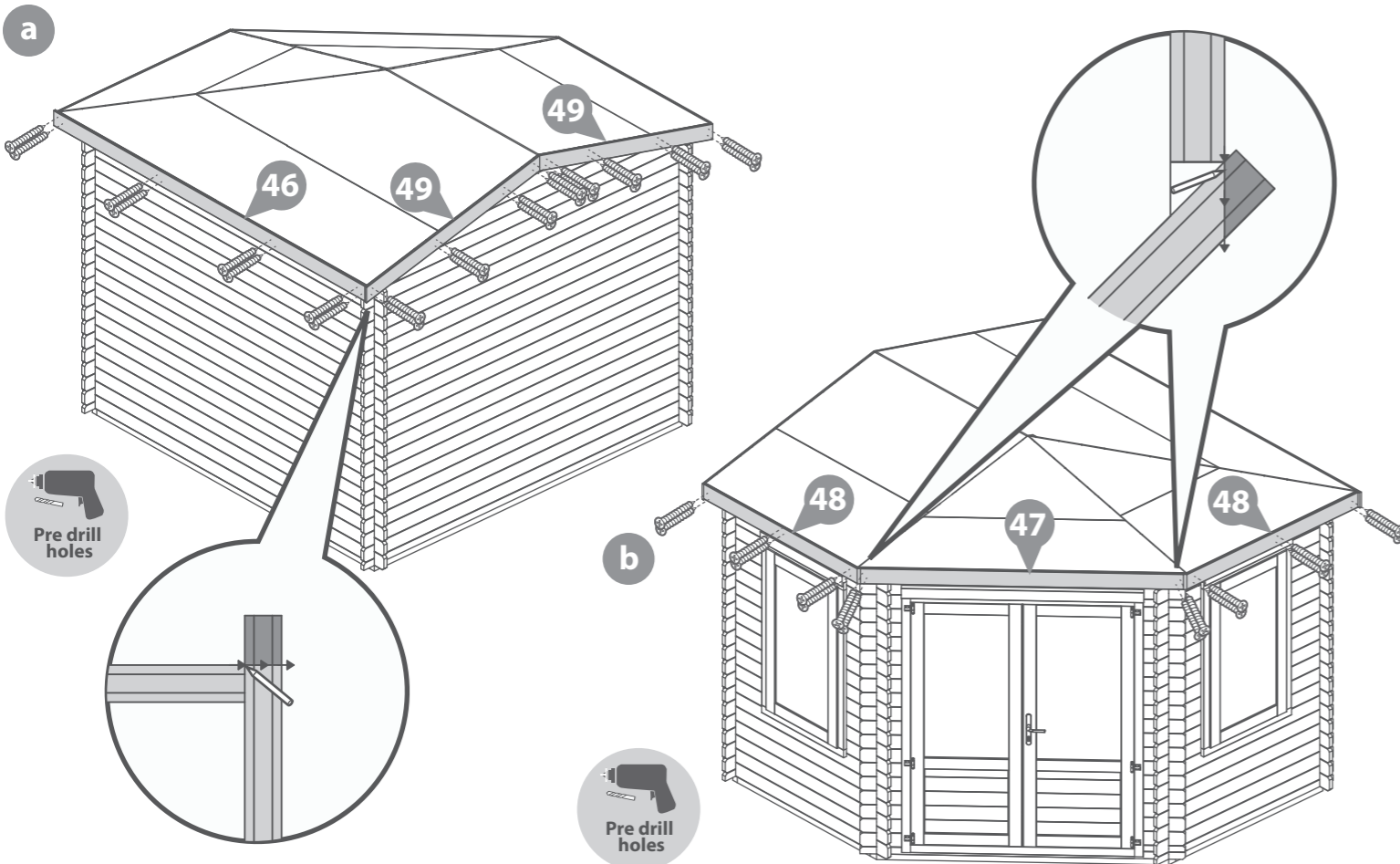

Step 46

- Parts Needed - No. 63 QTY 1**
- No. 70 QTY 2

Attach the Rain Guards (**No. 70**) to the Window frames, ensuring to position the rain guards directly above the windows, flush to the underside of the top framing, as shown. Make sure the rain guards are positioned centrally. Fix in place using 3x70mm screws.

Attach the Rain Guard (**No. 63**) to the Door frame, fixing in place onto the framing above the Door using 4x70mm screws.

****Please note:** This image is for illustrative purposes and may differ from the roof assembly you have constructed, however the process of fitting the rain guards is the same.

10x70mm Screws.
Important: Pre-drill before fixing screws.

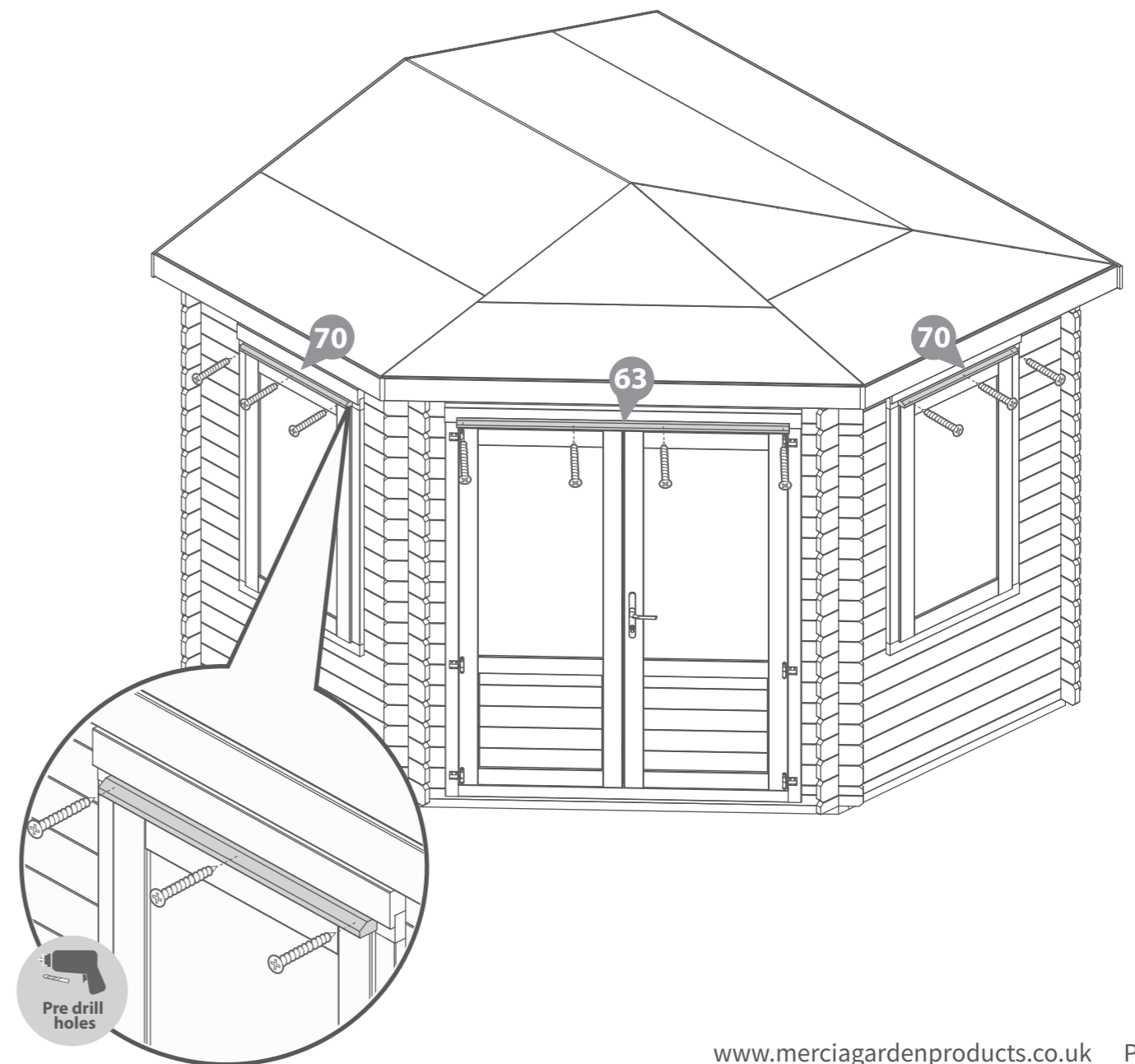
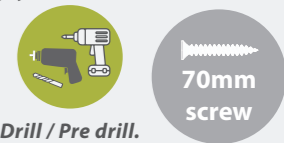

Step 47
Parts needed - No. 52 QTY 8

Arrange the storm braces (**No.52**) around the building (*internally*), placing two storm braces per wall.

***Ensure the storm braces are secured at the highest point possible on each side.**

Fix in place using 2x70mm bolts per brace, making sure the washer & nut are tightened from the outside of the building.

The storm braces will need to be altered during the buildings life as the moisture content within the log boards changes. The boards will expand during periods of high moisture (Winter) and shrink during periods of low moisture (Summer.)

****Storm braces are required to be adjusted during changes in humidity to allow the building to expand and contract. To do this, periodically loosen the bolts, adjust the storm brace position and re-tighten.**

*****Important: Ensure each bolt is tightened using a washer so as not to damage the log boards.***

***Please note:** This image is for illustrative purposes and may differ from the roof assembly you have constructed, however the process of fitting the storm braces is the same.

16x70mm Bolt Sets
Important: Pre-drill before fixing screws.

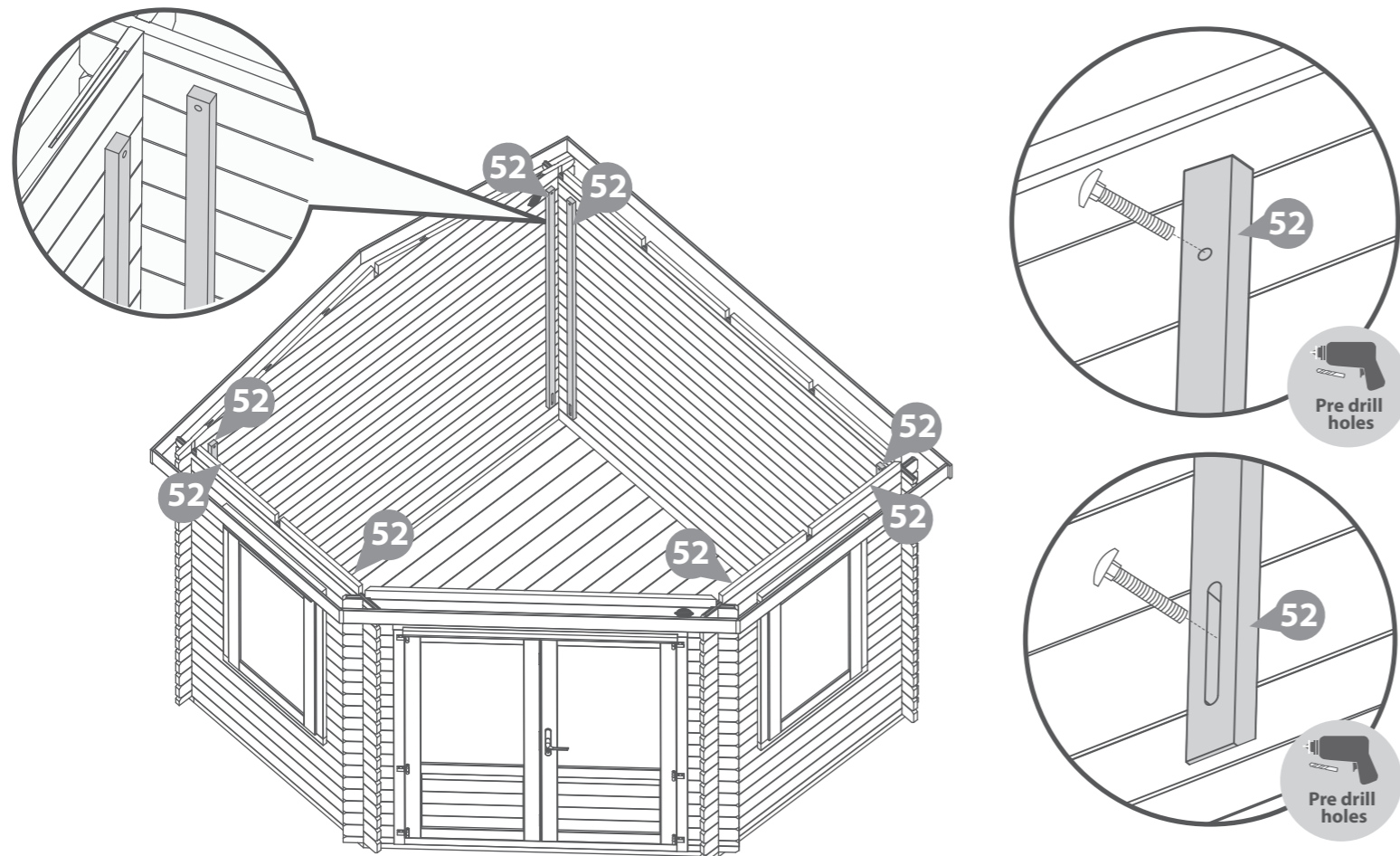

Step 48

Once constructed, apply a preserving and a waterproofing treatment to your garden building as soon as possible. This will help to protect your building and prevent decay.

See page 35 for a full guide and instructions.

****Please note:** This image is for illustrative purposes and may differ from the roof assembly you have constructed, however the process of treating the building is the same.

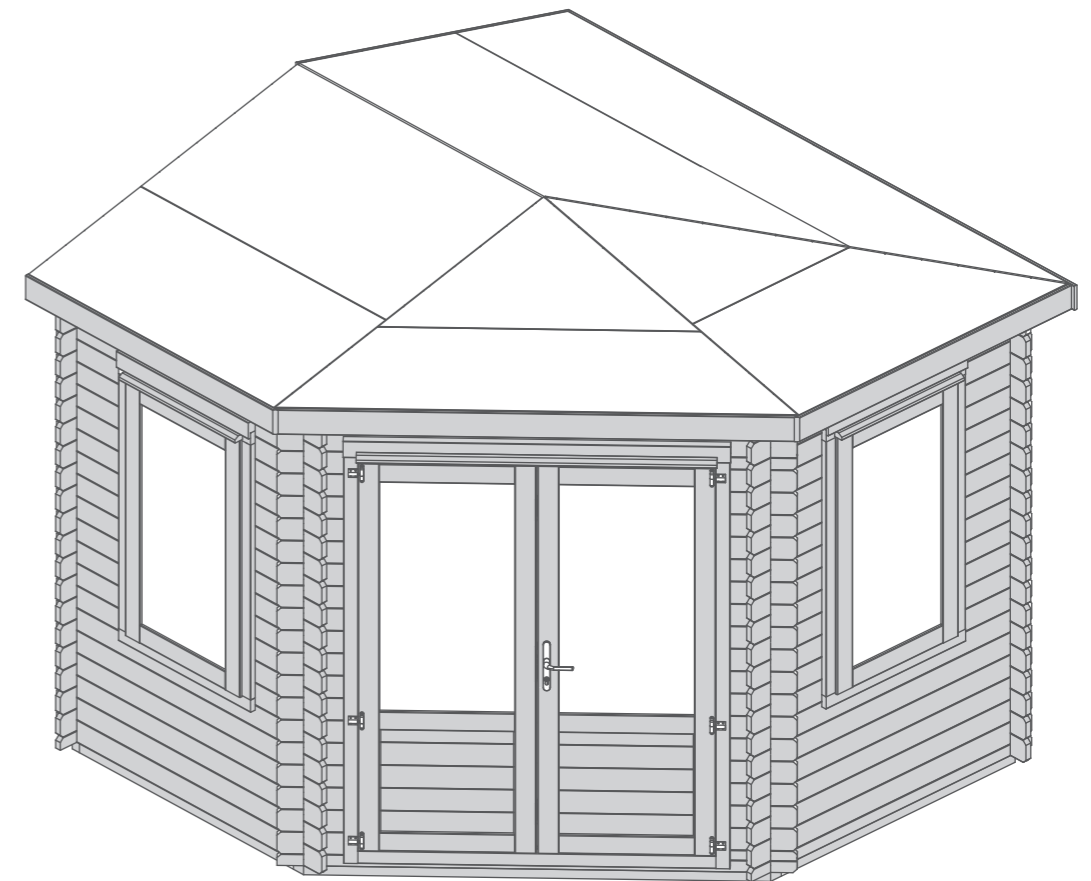

LEAVE US A REVIEW...

Want to share your experience with us? Leave us a review on Feefo, TrustPilot or Google.

Your reviews help other people find and trust our business, as well as helping to play an important role in our growth and improvement!

TREATING YOUR GARDEN BUILDING

Preservation of wood that's outdoors is vital. A little early care will help protect your garden building, improve its appearance and ensure maximum longevity. Insects, moisture, salt, and changing weather can have dramatic effects on the stability and appearance of your garden building. Once your building is installed, you've checked it over and you're happy with it, you can take a few basic precautions to prepare it for the elements. Treating your garden building helps prevent decay and, by repelling water, discourages the growth of moulds and fungi that could jeopardise the structural integrity of the wood.

Dip Treated buildings - Require a preservative treatment to protect against rot and decay and a waterproof treatment to prevent water ingress
Pressure Treated buildings - Require a waterproof treatment to prevent water ingress
Log Cabins/Insulated Garden Rooms - Are supplied untreated and require a preservative and waterproofing treatment.



ANY QUESTIONS?

Scan the QR code to contact us via our customer portal.

To apply a preservative and water proofing treatment (pressure treated products do not require a preserver), follow the manufacturer's instructions but in principle, stick to the following steps:

- ✓ Weather permitting, ensure to treat your garden building within 14 days of installation.
- ✓ Wear latex or rubber gloves, eye protection and (if spraying) a mask.
- ✓ Prepare the wood, by sanding down any ridges or inconsistencies in the wood, smoothing out knots and end-cuts.
- ✓ Choose a dry day to treat your garden building. If you're spraying rather than brushing paint on, avoid a windy day.
- ✓ Be sure you can safely reach all the sections you need to paint - and if you need a ladder, make sure it's safely positioned before climbing. Lay dust sheets around to avoid paint splatters on your base or surrounding plants.

- ✓ Tape around windowpanes to avoid smears when you're painting the frames.
- ✓ Keep pets and small children out of the way. The last thing you want is to have fur on your garden building paint, or little painted footprints all over your garden and home.
- ✓ Fill any gaps in the building's body with caulk or wood filler to prevent water and draughts getting in. Silicone based caulk is flexible and will move with the timber when temperature and humidity change. Allow to dry completely before treating. A handy tip for finding gaps is to go into your garden building and look for light leaking through joints and frames. If light gets in, then so will water.
- ✓ Liberally apply at least two coats of the treatment products with a brush or spray, taking care to allow the first coat to completely dry before applying the second.
- ✓ Make sure the solution permeates the whole of the surface area, especially around natural cracks, end cuts and nail/screw holes.



APPLY WOOD TREATMENT
IMMEDIATELY
AFTER ASSEMBLY

PLEASE SCAN HERE TO
SEE TREATMENT VIDEO:



1 Perimeter

Check around the perimeter of your product to ensure there are not trees or plants that are in contact with or overhanging the building. This can affect airflow and overhanging trees, or branches can damage the roof, it is advised to keep plants at a distance.

2 Repair

Inspect the interior and exterior of the product to look for splits, cracks, and holes. Although this is a natural occurrence it can be prevented. A wood filler can be used to close the splits, cracks, and holes.

3 Roof

Check your roof regularly for tears, splits, damaged wood and fallen debris. If you notice any of this immediate repair is critical.

4 Doors & Windows

Expansion and contraction can cause doors and windows to stick or become difficult to open. Small adjustments to the hinge position can be made to the doors and windows to allow free movement.

5 Oil

Hinges can seize up over time, apply lubricant to the hinges and locks annually.

6 Screws & Bolts

It is advised to check all screws and bolts and tighten any loose you might find. For log cabins specifically the storm braces will require loosening. During humidity and temperature changes (seasons) to allow expansion and contraction to prevent gaping, twisting, popping, and warping.

7 Wash

At least once a year, give the outside of your building a good wash, to remove cobwebs, leaves, or any other dirt that may accumulate on the exterior.

8 Airing

Airing your product regularly prevents the build up of condensation which can cause the timber to warp, bow, boards to pop, distortion, rot and mould. Condensation can build up over time or daily, it is caused by a rise and fall in temperature.

Excessive moisture levels within your building can cause water to collect on the roofs, walls and floors internally. Leaving doors and windows open regularly can help combat the natural moisture build up.

9 Storm Braces

The storm braces will need to be altered during the buildings life as the moisture content within the log boards changes, altering the braces will help your building expand and contract properly. The boards will expand during periods of high moisture (Winter) and shrink during periods of low moisture (Summer).

Ensure each bolt is tightened using a washer so as not to damage the log boards.

10 Clean & Tidy

It is good practice to clean the inside and outside of your product regularly. Clear out the contents, sweep the floor, remove dirt and cobwebs. Check for areas of damp and investigate the cause to remove and prevent future occurrences. Check the ground around your product for build up of debris such as leaves, remove and ensure there is clear ventilation underneath the floor.

Additional Playhouse Maintenance:

It is recommended that the following checks and maintenance are carried out at the beginning of each season as well as at regular intervals during the usage season.

- Check all nuts /bolts/ screws for tightness and tighten when required.
- Check for movement / opening of wood giving rise to protrusion of nail heads and tips.
- Check hinges.
- Replace defective parts in accordance with the manufacturers instructions.
- Check any crossbeams, suspensions and anchors.
- If a swing is included; check the swing seat, chains and ropes.

IF THESE CHECKS ARE NOT CARRIED OUT THE ACTIVITY TOY COULD BECOME A HAZARD

All our garden buildings have been designed and manufactured with care and attention to be the perfect addition to your outdoor space. To ensure you do get the best out of your new garden building and to increase the longevity we advise that you follow the product instructions and our manufacturer's recommendations as detailed below. Thank you for choosing a Mercia Garden product!

1 Choosing the most suitable location for your garden building...

A minimum of 60cm should be left around the perimeter of your garden building to allow access for maintenance, annual treatment and to allow air flow around the building.

Where possible you should avoid placing your garden building underneath large trees to prevent the tree causing damage to the building.

2 Preparing the base for your garden building...

All our buildings must be built on a firm, level base to ensure the longevity of the building and prevent the wood from distorting. We recommend either concrete, concrete slabs or a wooden base, such as our 'Portabase'.

The base should be slightly smaller than the external measurement of the building, i.e. the cladding should overlap the base, creating a run off for water and preventing water from pooling underneath the building.

We also recommend that the floor of the garden building is a minimum of 25mm above the surrounding ground level to avoid flooding.

3 After installation...

Once your garden building has been installed, it will need to be treated within 14 days (weather permitting) and annually to prevent the timber from deteriorating and to waterproof it. This is required to maintain the anti-rot guarantee.

Dip Treated buildings - Require a preservative treatment to protect against rot and decay and a waterproof treatment to prevent water ingress.

Pressure Treated buildings - Require a waterproof treatment to prevent water ingress.

Log Cabins/Insulated Garden Rooms - Are supplied untreated and require a preservative and waterproofing treatment.

We also recommend using a silicon sealant on the inside and outside of the windows as soon as possible after assembly and treatment to fully seal the windows.

Roofing felt/covering should be checked annually and replaced or fixed accordingly.

4 General maintenance and wood characteristics

As wood is a natural material it may be affected by the following:

Shrinkage and warping - The timber used in the construction of your garden building will have retained some of its natural moisture content. The moisture content of the timber will vary, depending upon prevailing environmental conditions, which will result in the components either naturally expanding or contracting. As the components dry out, shrinkage may occur. A good waterproofing treatment from the start is the best protection to minimise the effect of moisture loss/intake.

In extended periods of very warm weather getting some moisture to the building will help the overall balance. You can do this by spraying it down lightly with a garden hose. In contrast, after snow fall try to remove the snow as best as possible from the roof to prevent moisture intake and to remove the extra weight.

Top tip - using a garden brush will help you to reach the highest part of the building to remove snow and any debris left from bad weather.

Damp and mould - During the winter months, cold and damp conditions can result in an increased amount of moisture within your garden building, especially when used infrequently. Condensation can form on the timber and other items stored within your garden building. If left this moisture is likely to cause mould and mildew.

To prevent the build-up of moisture, we recommend leaving the door or windows of your building open from time to time, to allow the fresh air to circulate. We also advise against storing wet or damp items in your garden building as this will also increase the level of moisture in the building. If mould or mildew does start to form within your building we recommend using an anti-mould cleaner to remove it and to prevent it spreading, which if left untreated could permanently damage your garden building.

Splits, cracks and knots - You may notice small splits and cracks in some components or holes may appear where knots shrink and fall out. This will not affect the structure of your Garden building however, if you wish to fill them this can be easily done using any good quality wood filler.

Sap - is naturally occurring in wood and may appear in some boards of your garden building. If you wish to remove the sap, we advise waiting until it is dry and then using a sharp knife to carefully remove it. If the removal of the sap causes a hole in the timber, we recommend using a good quality wood filler to fill it.

For more handy hints and tips on how to care and maintain your garden building please refer to the MGP Customer Portal at www.mgplogistics.co.uk

Any further questions?

Contact our
Customer Service Team via the MGP
Customer Portal at:
www.mgplogistics.co.uk

1

Manufacturer's Warranty

All Mercia Garden Products are supplied with a 1 year warranty on all parts against manufacturing defects.

This warranty does not cover movement, warping or splitting of timber products over time.

This warranty will be voided if any of the following occur:

1. The building has been customised or modified/adapted in any way.
2. The person claiming is not the original purchaser of the building.
3. Any damage has been caused by or as a result of misuse.
4. The building has not been maintained and cared for in accordance to our advisories and manufacturer's recommendations.
5. The building has not been treated annually or as per the manufacturer's recommendations, please ensure receipts are kept to validate this claim.
6. The building has not been erected, fitted or installed as per the supplier instructions.
7. The building has not been erected on a suitable sized firm flat, solid level concrete/slab base or placed on pressure treated bearers.
8. The building is or has been placed with 2 feet (600mm) of any obstructions (walls, trees, plants, fences etc.) which can allow moisture to penetrate the timber.
9. The roofing felt has been incorrectly fitted or damaged, allowing water ingress, or has not been properly maintained.
10. Any windows and joints have not been sealed, inside and out, with silicone or other watertight sealant.
11. Any timber has been cut, pierced or drilled without subsequent application of approved cut-end treatment.

2

Anti-rot Guarantee

Mercia Garden Products offer a 10 year anti-rot guarantee on all dip treated (a preparatory treatment) and 15 years on all pressure treated products. This guarantee covers solid timber against rot, decay, blue stain and insect attacks.

To validate the guarantee the building must be treated (as detailed within manufacturer's recommendations) within 14 days (weather permitting) of assembly and annually thereafter.

This guarantee does not cover movement, warping or splitting of timber products over time.

This guarantee will be voided if any of the following occur:

1. The building has been customised or modified/adapted in any way.
2. The person claiming is not the original purchaser of the building.
3. Any damage is caused by or as a result of misuse.
4. The building has not been maintained and cared for in accordance to our advisories and manufacturer's recommendations.
5. The building has not been treated annually or as per the manufacturer's recommendations, please ensure receipts are kept to validate this claim.
6. The building has not been erected, fitted or installed as per the supplier instructions.
7. The building has not been erected on a suitable sized firm flat, solid level concrete/slab base or placed on pressure treated bearers.
8. The building is or has been placed with 600mm of any obstructions (walls, trees, plants, fences etc.) which can allow moisture to penetrate the timber.
9. The roofing felt has been incorrectly fitted or damaged allowing water ingress, or has not been properly maintained.
10. Any windows and joints have not been sealed, inside and out, with silicone or other watertight sealant.
11. Any timber has been cut, pierced or drilled without subsequent application of approved cut-end treatment.



REGISTER FOR YOUR
ANTI-ROT
GUARANTEE TODAY

PLEASE SCAN HERE:

