

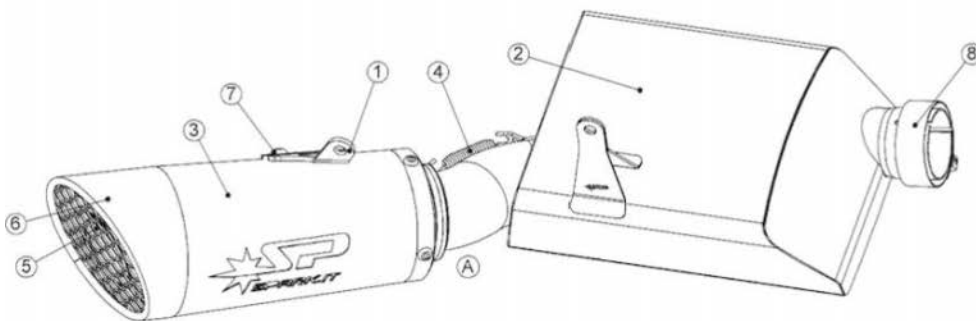

ISTRUZIONI DI MONTAGGIO / INSTALLATION ISTRUCTION

MODEL: TRIUMPH STREET TRIPLE RS / R / S



Num. articolo	Num. parte	Descrizione	Quantità
1	SGATT672	Attacco silenziatore triumph street triple	1
2	SGCM32230011	Box Silenziatore Triumph Street Triple	1
3	SGCM30175002T	Sil Grid-O	1
4	MOLLA07	Molla corta, con gommino, int. 68	1
5	G9980	DB Killer Grid-O	1
6	VITE6X*6ITT		1
7	VITE8X12ITT		2
8	G95LA007	fascetta stringitubo D47	1
	DADOM8ZR		1

SMONTAGGIO ORIGINALE / REMOVING THE ORIGINAL EXHAUST

1. Rimuovere le viti di fissaggio originali contrassegnate nelle figura sotto

1. Remove the original screws marked in red color below

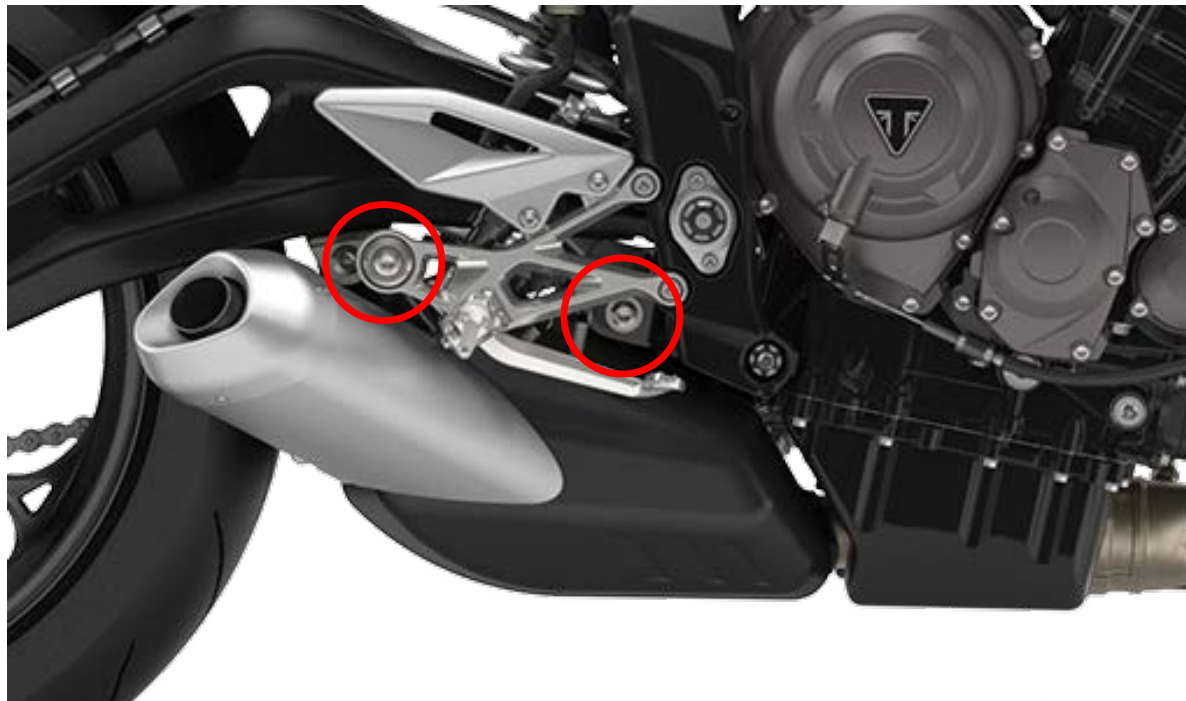

2. Allentare la fascetta stringitubo originale posta sotto al carter paracalore nella parte sinistra della moto, poi rimuovere il silenziatore originale

2. Loosen the original clamp which is under the heat shield, on the left side of the motorbike. Then, remove the original silencer



INSTALLAZIONE / INSTALLING SPARK EXHAUST

1. Installare il Box presilenziatore con la fascetta stringitubo Spark preinstallata sul raccordo e fissare la staffa al telaio con la vite originale e un dado M8 in dotazione (non stringere completamente le viti)

1. Mount the Box with Spark clamp which is already installed on the connecting tube. Fix the holder to the frame with the original screw and the M8 nut provided in the kit (do not fully tighten the screw)



2. Montare il silenziatore Spark fissandolo alla pedana con la vite e bullone originali senza stringere completamente la vite

2. Fix Spark silencer to the rearset with the original screw and nut – do not fully tighten the screw



INSTALLAZIONE / INSTALLING SPARK EXHAUST

3. Stringere tutte le viti tenendo spostato il silenziatore dal forcellone ad una distanza di 15-20mm
3. *Tighten all screws making sure that the silencer is 15-20mm far from the swingarm*



4. Se necessario, allentare le 2 viti della staffa silenziatore in modo da far combaciare i fori per inserire la vite originale nella pedana e nella staffa silenziatore stringendola con il bullone, poi stringere le viti sul silenziatore.

4. *If the holder does not match to the rearset perfectly, loosen the holder's screws in order to fix the original screw and nut to the rearset, then tighten the holder's screws*



5. Agganciare la molla dietro al silenziatore
5. *Hook the spring behind the silencer*





@Spark.Exhaust.Technology



@SPARKEXHAUST



GRAZIE per aver scelto un prodotto Spark Exhaust Technology!
100% made in Italy, 100% realizzato per dar forma alla passione per le 2 ruote.
Con il tuo acquisto, sei entrato a far parte del mondo Spark: inviaci a info@spark.it foto o video della tua moto col nostro scarico, le inseriremo sulla nostra pagina ufficiale Facebook e Instagram.
Inoltre, se hai suggerimenti, idee, osservazioni... saremo ben felici di ascoltare il tuo parere per migliorarci!

Thank you for choosing Spark Exhaust Technology!
100% Made in Italy, 100% produced to give shape to passion for 2 wheels.
As a result of your purchase, you are part of our world: send us at info@spark.it a photo or video of your motorbike with Spark exhaust, we will publish them on our official Facebook page and Instagram. Moreover, if you have any suggestion, idea or remark, we will be happy to know your opinion to improve more and more!