



SP0066

**FITTING INSTRUCTIONS FOR SP0066BK SWING-ARM PROTECTORS  
DUCATI SCRAMBLER 2015-**

Page | 1



**THIS KIT CONTAINS THE ITEMS PICTURED AND LABELLED BELOW.  
DO NOT PROCEED UNTIL YOU ARE SURE ALL PARTS ARE PRESENT.**

Please note that the way the kit is packed does not necessarily represent the way of mounting to the bike

THE PARTS SHOWN MAY BE REPRESENTATIVE ONLY (FOR CLARITY OF INSTRUCTIONS ONLY)

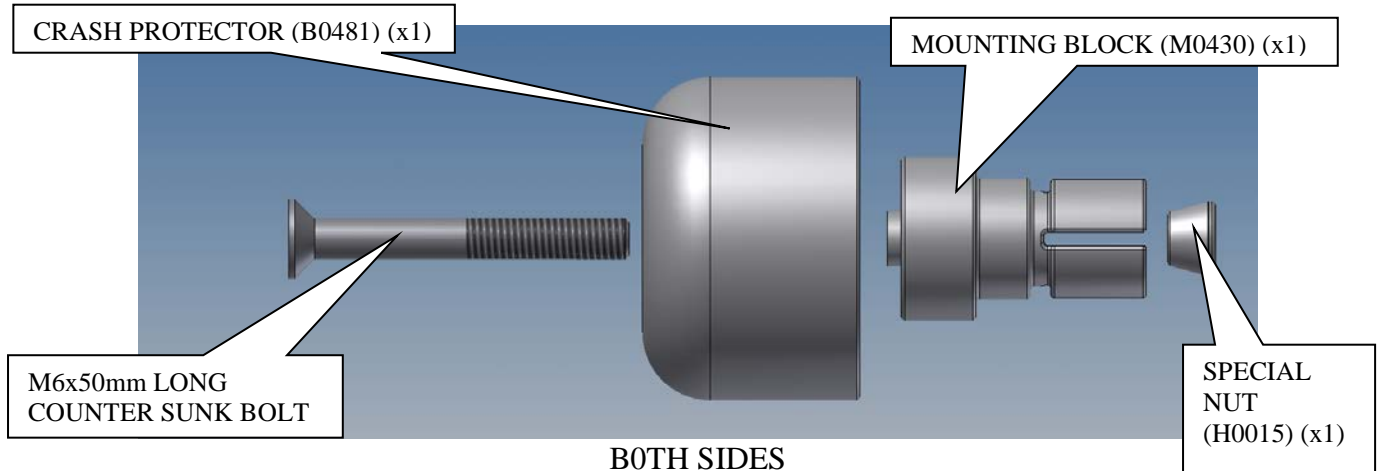

Please note that in cases where kits are packed with rubber washers holding the components onto the bolt – *the rubber washers should be thrown away!*

**TOOLS REQUIRED**

- 4mm metric Allen key.

**Either side**

- Fit the counter sunk bolt through the crash protector so head sits in counter-sink.
- Place the crash protector on to the mounting block.
- Place special nut on exposed end of bolt so tapered face goes into recess of the mounting block.

R&G Racing  
Unit 1, Shelleys Lane, East Worldham, Alton, Hampshire, GU34 3AQ

Tel: +44 (0) 1420 89007 | Fax : +44 (0) 1420 87301 | Email: info@rg-racing.com



SP0066

- Tighten bolt until tapered portion of nut just contacts in the recessed face of the mounting block.
- Place this assembly into the left hand side of the rear wheel spindle.
- Tighten the bolt so crash protector is held in position firmly (do not over tighten).
- Repeat for opposite side.
- **Regularly check to ensure crash protector remains tight.**

Page | 2

**Digital copies of these instructions are available to download from [www.rg-racing.com](http://www.rg-racing.com)**

#### **GENERAL TORQUE SETTINGS**

- M4 BOLT = 8Nm
- M5 BOLT = 12Nm
- M6 BOLT = 15Nm
- M8 BOLT = 20Nm
- M10 BOLT = 40Nm

Issue 1 20/03/2015 (NSY)

#### **CONSUMER NOTICE**

The catalogue description and any exhibition of samples are only broad indications of the Products and R&G may make design changes which do not diminish their performance or visual appeal and supplying them in such state shall conform to the order. The Buyer acknowledges no representation or warranty (other than as to title) has been given or will apply to the Products other than those in R&G's order or confirmation and the Buyer confirms it has chosen the Products as being of merchantable quality and suitable for its particular purposes. Where R&G fits the Products or undertakes other services it shall exercise reasonable skill and care and rectify any fault free of charge unless the workmanship has been disturbed. The Buyer is responsible for ensuring that the warranty on the motorcycle is not affected by the fitting of the Products. On return of any defective Products R&G shall at its option either supply a replacement or refund the purchase money but shall not be liable if the Products have been modified or used or maintained otherwise than in accordance with R&G's or manufacturer's instructions and good engineering practice or if the defect arises from accident or neglect. Other than identified above and subject to R&G not limiting its liability for causing death and personal injury, it shall not be liable for indirect or consequential loss and otherwise its liability shall be limited to the amounts paid by the Buyer for the Products or the fitting or service concerned. These terms do not affect the Buyer's statutory rights.

#### **R&G RACING RETURNS POLICY (NON-FAULTY GOODS)**

Returns must be pre-authorized (if not pre-authorized the return will be rejected). Goods may only be returned direct to us if they were purchased direct from us (customer must prove if necessary). Otherwise to be returned to original vendor. Goods must be in re-sellable condition, in the opinion of R&G Racing. All returns are subject to a 25% restocking and handling fee (25% of the gross value exc. P&P – at the prevailing price at time of purchase). The customer must pay any and all carriage charges. No returns of discontinued products, unless within 14 days of purchase. This policy does not affect your statutory rights and does not refer to faulty goods.

R&G Racing  
Unit 1, Shelleys Lane, East Worldham, Alton, Hampshire, GU34 3AQ

Tel: +44 (0) 1420 89007 | Fax : +44 (0) 1420 87301 | Email: [info@rg-racing.com](mailto:info@rg-racing.com)



SP0066

**INSTRUCTIONS DE MONTAGE POUR SP0061BK PROTECTION BRAS**  
**OSCILLANT**  
**DUCATI SCRAMBLER 2015**

Page | 3



**Le kit contient les articles exposés ci-dessous, vérifier que toutes les pièces soient présentes avant de procéder au montage.**

**La façon dont le kit est emballé ne correspond pas forcément à la façon de monter les pièces sur la moto.**

**LES PARTIES PRESENTEES PEUVENT ETRE UNIQUEMENT REPRESENTATIVES (POUR LA CLARTE DES INSTRUCTIONS UNIQUEMENT)**

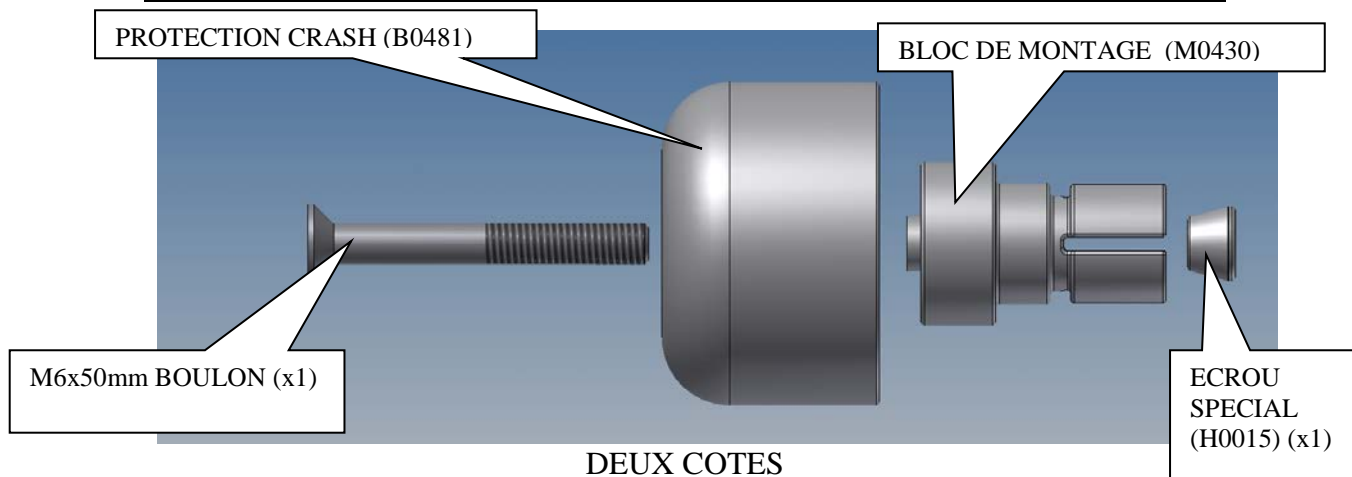

Notez que si les kits sont emballés avec des rondelles en caoutchouc servant à tenir les composants, *ces rondelles doivent être jetées.*

**Outils requis**

- Clé Allen 4mm.

R&G Racing  
Unit 1, Shelleys Lane, East Worldham, Alton, Hampshire, GU34 3AQ

Tel: +44 (0) 1420 89007 | Fax : +44 (0) 1420 87301 | Email: info@rg-racing.com



SP0066

### **Coté gauche assis sur la moto:**

### **Les deux cotés :**

Page | 4

- Insérer le boulon à travers la protection crash de façon à ce que la tête aille dans le contre alésage.
- Placer la protection crash sur le bloc de montage..
- Placer l'écrou spécial sur le filetage exposé du boulon de façon à ce que la face conique aille dans le creux du bloc de montage.
- Serrer le boulon jusqu'à ce que la partie conique de l'écrou rentre en contact dans le creux du bloc de montage.
- Placer cet ensemble du coté gauche de l'axe de roue arrière.
- Serrer le boulon pour que la protection crash soit maintenue en position (ne pas bloquer).
- Appliquer la même procédure de l'autre coté
- **Vérifier le serrage régulièrement.**

Issue 1 20/03/2015 (NSY)

#### **CONSUMER NOTICE**

The catalogue description and any exhibition of samples are only broad indications of the Products and R&G may make design changes which do not diminish their performance or visual appeal and supplying them in such state shall conform to the order. The Buyer acknowledges no representation or warranty (other than as to title) has been given or will apply to the Products other than those in R&G's order or confirmation and the Buyer confirms it has chosen the Products as being of merchantable quality and suitable for its particular purposes. Where R&G fits the Products or undertakes other services it shall exercise reasonable skill and care and rectify any fault free of charge unless the workmanship has been disturbed. The Buyer is responsible for ensuring that the warranty on the motorcycle is not affected by the fitting of the Products. On return of any defective Products R&G shall at its option either supply a replacement or refund the purchase money but shall not be liable if the Products have been modified or used or maintained otherwise than in accordance with R&G's or manufacturer's instructions and good engineering practice or if the defect arises from accident or neglect. Other than identified above and subject to R&G not limiting its liability for causing death and personal injury, it shall not be liable for indirect or consequential loss and otherwise its liability shall be limited to the amounts paid by the Buyer for the Products or the fitting or service concerned. These terms do not affect the Buyer's statutory rights.

#### **R&G RACING RETURNS POLICY (NON-FAULTY GOODS)**

Returns must be pre-authorized (if not pre-authorized the return will be rejected). Goods may only be returned direct to us if they were purchased direct from us (customer must prove if necessary). Otherwise to be returned to original vendor. Goods must be in re-sellable condition, in the opinion of R&G Racing. All returns are subject to a 25% restocking and handling fee (25% of the gross value exc. P&P – at the prevailing price at time of purchase). The customer must pay any and all carriage charges. No returns of discontinued products, unless within 14 days of purchase. This policy does not affect your statutory rights and does not refer to faulty goods.

R&G Racing

Unit 1, Shelleys Lane, East Worldham, Alton, Hampshire, GU34 3AQ

Tel: +44 (0) 1420 89007 | Fax : +44 (0) 1420 87301 | Email: info@rg-racing.com



SP0066

**MONTAGEANLEITUNG FÜR SP0066BK SCHWINGENPROTEKTOREN  
DUCATI SCRAMBLER 2015-**

Page | 5



**ALLE TEILE SIND UNTEN ABGEBILDET UND GEKENNZEICHNET. BEVOR SIE MIT DER MONTAGE BEGINNEN, ÜBERPRÜFEN SIE, DASS ALLE TEILE VORHANDEN SIND.**

**Hinweis: Die Verpackung der Teile stellt nicht die Reihenfolge der Montage dar.**

DIE UNTEN ABGEBILDETEN TEILE DIENEN LEDIGLICH ZUR ERKLÄRUNG

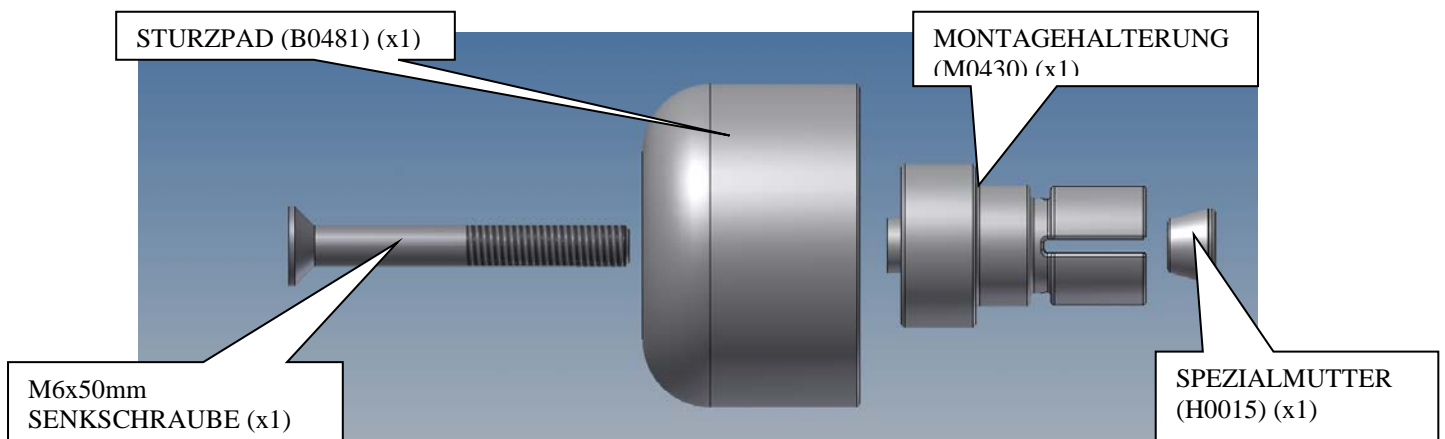

**AN BEIDEN SEITEN**

Hinweis für Kits mit Plastikunterlegscheiben an den Schrauben – Diese Plastikunterlegscheiben werden nicht für den Einbau benötigt!

**SIE BENÖTIGEN FOLGENDES WERKZEUG:**

- 4mm Inbusschlüssel

R&G Racing  
Unit 1, Shelleys Lane, East Worldham, Alton, Hampshire, GU34 3AQ

Tel: +44 (0) 1420 89007 | Fax : +44 (0) 1420 87301 | Email: info@rg-racing.com



SP0066

## Montage an beiden Seiten

Page | 6

- Führen Sie die Senkschraube in das Sturzpad ein, so dass der Schraubenkopf in der Senkbohrung sitzt.
- Das Sturzpad an der Montagehalterung anbringen.
- Die Spezialmutter am Schraubende anbringen, sodass die gestufte Fläche in den Ausschnitt der Montagehalterung reinpasst.
- Ziehen Sie die Schraube fest, bis die gestufte Fläche der Mutter die Ausschnittfläche der Montagehalterung berührt.
- Diese Einheit in die linke Seite der Hinterradachse einführen.
- Ziehen Sie die Schraube fest, um das Sturzpad in Position zu befestigen (nicht überdrehen).
- Diese Schritte an der rechten Seite wiederholen.
- **Überprüfen Sie regelmäßig, dass der Schwingenprotektor noch fest fixiert ist.**

**Eine digitale Version dieser Montageanleitung kann auf folgender Seite heruntergeladen werden:**

[www.rg-racing.com](http://www.rg-racing.com)

### ANZUGSDREHMOMENTE:

- M4 SCHRAUBE = 8Nm
- M5 SCHRAUBE = 12Nm
- M6 SCHRAUBE = 15Nm
- M8 SCHRAUBE = 20Nm
- M10 SCHRAUBE = 40Nm

Ausgabe 1 20/03/2015 (NSY)

#### CONSUMER NOTICE

The catalogue description and any exhibition of samples are only broad indications of the Products and R&G may make design changes which do not diminish their performance or visual appeal and supplying them in such state shall conform to the order. The Buyer acknowledges no representation or warranty (other than as to title) has been given or will apply to the Products other than those in R&G's order or confirmation and the Buyer confirms it has chosen the Products as being of merchantable quality and suitable for its particular purposes. Where R&G fits the Products or undertakes other services it shall exercise reasonable skill and care and rectify any fault free of charge unless the workmanship has been disturbed. The Buyer is responsible for ensuring that the warranty on the motorcycle is not affected by the fitting of the Products. On return of any defective Products R&G shall at its option either supply a replacement or refund the purchase money but shall not be liable if the Products have been modified or used or maintained otherwise than in accordance with R&G's or manufacturer's instructions and good engineering practice or if the defect arises from accident or neglect. Other than identified above and subject to R&G not limiting its liability for causing death and personal injury, it shall not be liable for indirect or consequential loss and otherwise its liability shall be limited to the amounts paid by the Buyer for the Products or the fitting or service concerned. These terms do not affect the Buyer's statutory rights.

#### R&G RACING RETURNS POLICY (NON-FAULTY GOODS)

Returns must be pre-authorized (if not pre-authorized the return will be rejected). Goods may only be returned direct to us if they were purchased direct from us (customer must prove if necessary). Otherwise to be returned to original vendor. Goods must be in re-sellable condition, in the opinion of R&G Racing. All returns are subject to a 25% restocking and handling fee (25% of the gross value exc. P&P – at the prevailing price at time of purchase). The customer must pay any and all carriage charges. No returns of discontinued products, unless within 14 days of purchase. This policy does not affect your statutory rights and does not refer to faulty goods.

R&G Racing  
Unit 1, Shelleys Lane, East Worldham, Alton, Hampshire, GU34 3AQ

Tel: +44 (0) 1420 89007 | Fax : +44 (0) 1420 87301 | Email: [info@rg-racing.com](mailto:info@rg-racing.com)