

### Kit Contents

Description	Part No	Pcs
Shock absorber	KA841	1
Screw M6x14	00382-16	1
Bracket	21617-01	1
Bracket reservoir 44	03102-05	1
Screw M8x30	05404-09	2
Washer	00426-06	2
Screw M6x12	05404-01	2
Tie rap	00231-02	3
Preload adj. tool	03199-03	1
Öhlins sticker	00192-01	2
Owner's manual	07241-02	1

#### 👁 Note!

Please note that this image is a general representation of the product and may differ slightly from your product.

#### 👁 Note!

Please note that during storage and transportation, especially at high ambient temperature, some of the oil and grease used for assembling may leak and stain the packaging. This is in no way detrimental to the product, wipe off the excessive oil/grease with a cloth.

#### 👁 Note!

Before installing this product, check the contents of the kit. If anything is missing, please contact an Öhlins dealer.

#### ⚠ Warning!

Before installing this product, read the Öhlins Owner's Manual. The shock absorber/front fork/steering damper is an important part of your vehicle and will affect the stability.

## Shock absorber for Kawasaki Ninja 300

# KA 841

## Mounting Instructions

# MOUNTING INSTRUCTIONS

## **⚠ Warning!**

*It is advisable to have an Öhlins dealer install the shock absorber/front fork/steering damper.*

## **⚠ Warning!**

*If working on a raised vehicle, ensure it is securely supported so that it will not tip.*

## **👁 Note!**

*Before mounting this product clean the vehicle thoroughly.*

## **👁 Note!**

*When working on this product, always see the Vehicle Service Manual for vehicle specific procedures and important data.*

**1**

Put the motorcycle on a workstand so that the rear wheel barely touches the ground.

**2**

Loosen the lower shock absorber screw.

**3**

Loosen the linkage.

**4**

Loosen the upper shock absorber screw.

**5**

Remove the original shock absorber.

**6**

Install the Öhlins shock absorber with the hose pointing to the left.

**7**

Tighten all screws according to vehicle service manual.

**8**

Assemble the pressure reservoir brackets according to figure.

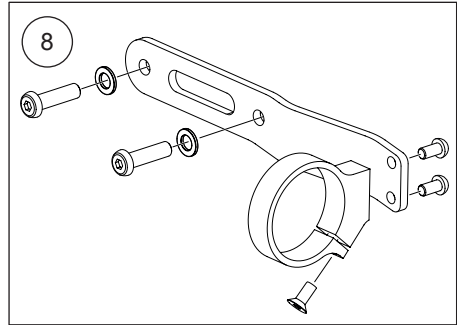

**9**

Install the pressure reservoir assembly according to the figure.

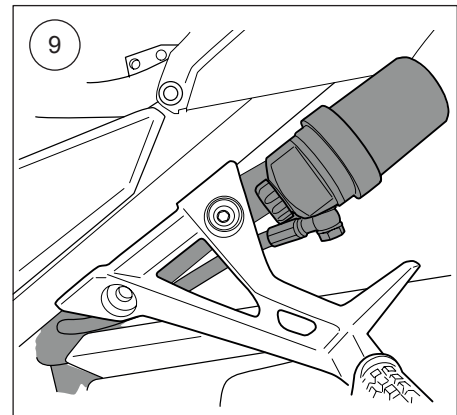

**10**

Fixate the hose with the tie raps provided.

## **👁 Note!**

*Lower the vehicle so that the suspension is slightly compressed before tightening the screws.*

## **👉 Caution!**

*Ensure that all screws are tightened to the correct torque and that nothing fouls or restricts movement of the shock absorber/front fork/steering damper when the suspension is fully compressed or extended.*

# MOUNTING INSTRUCTIONS

# ADJUSTMENTS

## ⚠ Warning!

Before riding, always make sure that the basic settings made by Öhlins are according to recommended Set-up Data. Read about adjustments and setting up in the Öhlins Owner's Manual before you make any adjustments. Contact an Öhlins dealer if you have any questions about setting up.

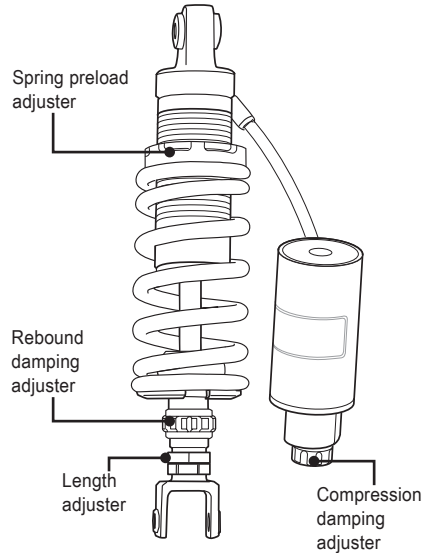

## SET-UP DATA

Length	320 <sup>+6</sup> / <sub>-2</sub>	mm
Stroke	63	mm
Rebound	10	clicks
Compression	10	clicks
Spring preload	8	mm
Spring	00281-57	
Spring rate	80	N/mm

👁 Öhlins products are subject to continuous improvement and development, therefore, although these instructions include the most up-to-date information available at the time of printing, minor updates may occur.

To find the latest information contact an Öhlins distributor. Please contact Öhlins if you have any questions regarding the contents in this document.

Part no. MI\_KA841\_1  
Issued 2014-03-10

© Öhlins Racing AB. All rights reserved. Any reprinting or unauthorized use without the written permission of Öhlins Racing AB is prohibited.

Öhlins Racing AB  
Box 722  
S-194 27 Upplands Väsby, Sweden  
Phone +46 8 590 025 00  
fax +46 8 590 025 80



[www.ohlins.com](http://www.ohlins.com)