

### **👁 Note!**

*Before installing this product, check the contents of the kit. If anything is missing, please contact an Öhlins dealer.*

### **Kit Contents**

Description	Part No	Pcs
Shock absorber	PI 301	1
Screw M8x25	01046-03	2
Screw M8x45	01046-72	2
Sticker set	10207-01	1
Owners manual	07241-02	1
Tool preload adjuster	03199-03	1

### **👁 Note!**

*Please note that this image is a general representation of the product and may differ slightly from your product.*

### **👁 Note!**

*Please note that during storage and transportation, especially at high ambient temperature, some of the oil and grease used for assembling may leak and stain the packaging. This is in no way detrimental to the product, wipe off the excessive oil/grease with a cloth.*

### **⚠ Warning!**

*Before installing this product, read the Öhlins Owner's Manual. The shock absorber is an important part of your vehicle and will affect the stability.*

## **Shock Absorber for Vespa LX 125/ S 125 - Front**

# **PI 301**

## **Mounting Instructions**

# MOUNTING INSTRUCTIONS

## **⚠ Warning!**

*It is advisable to have an Öhlins dealer install the shock absorber.*

## **⚠ Warning!**

*If working on a raised vehicle, ensure it is securely supported so that it will not tip over.*

## **👁 Note!**

*When working on this product, always see the Vehicle Service Manual for vehicle specific procedures and important data.*

## **👉 Caution!**

*Make sure that all screws are tightened to the correct torque and that nothing fouls or restricts movement of the shock absorber when the suspension is fully compressed or extended.*

**1**

Put the motorcycle on a work stand so that the front wheel barely touches the ground. Make sure the motorcycle is in a stable position.

**2**

Remove the front wheel as per motorcycle service manual instructions.

**3**

Uptighten the shock absorber lower mounting screws (1), (2).

1-2

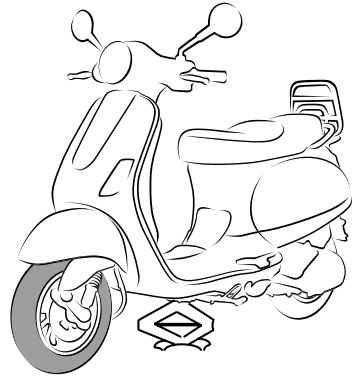

3

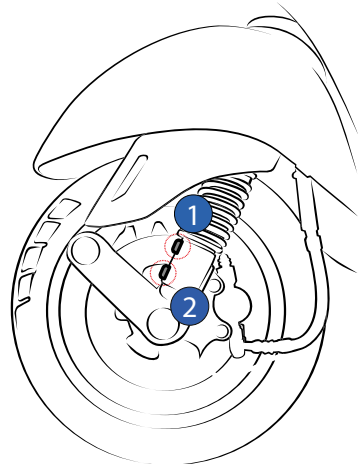

# MOUNTING INSTRUCTIONS

4

Remove the clamp screw (3) and 2 top mounting screws (4), (5).

4

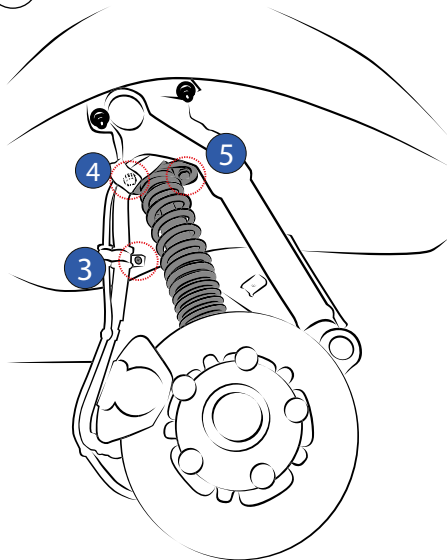

5

Remove the top plate from the standard shock absorber by loosening the nut (6).

5

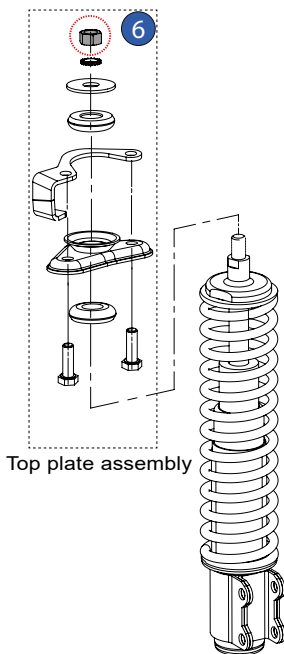

# MOUNTING INSTRUCTIONS

6

Install the standard top plate onto the Öhlins shock absorber in the same order. Tighten the nut (6) at a torque value as specified in the Vespa service manual instruction.

**Note!**

*Used screw M8x25 replace standard screw.*

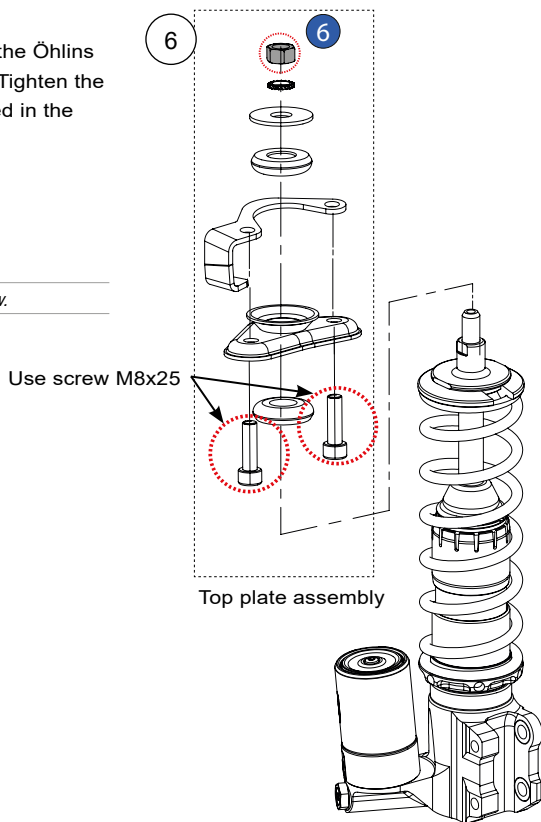

# MOUNTING INSTRUCTIONS

7 Tighten the lower mounting screws (7) and (8) at 24 Nm. Use threadlocker (Eg. Loctite) to secure the screws.

7

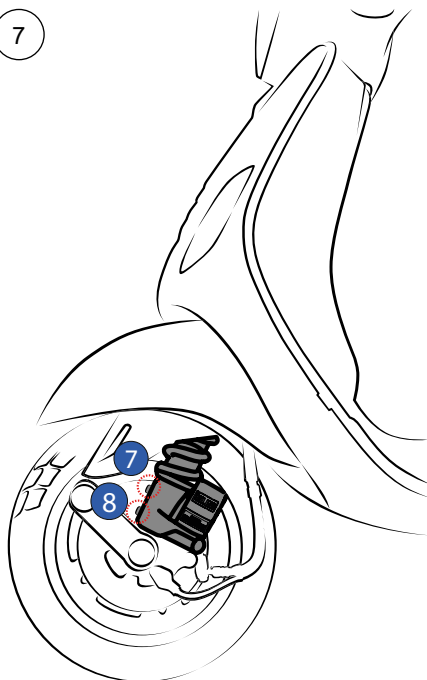

8  
Reverse all the procedures as necessary

This page intentionally left blank

This page intentionally left blank

# ADJUSTMENTS

## ⚠ Warning!

Before riding, always make sure that the basic settings made by Öhlins are according to recommended Set-up Data. Read about adjustments and setting up in the Öhlins Owner's Manual before you make any adjustments. Contact an Öhlins dealer if you have any questions about setting up.

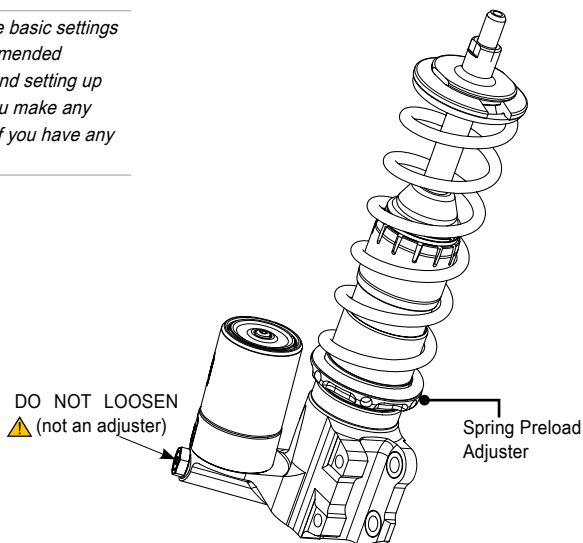

## SET-UP DATA

### Recommended set-up

Spring Preload ..... 3 mm

### Spring

Part No ..... 60001-52

Free spring length ..... 170 mm

Spring rate ..... [13-20]N/mm

Preload adjustment range.. [3-22]mm

### Shock absorber data

Length ..... 247.5 mm

Stroke ..... 74.5 mm

👁 Öhlins products are subject to continuous improvement and development, therefore, although these instructions include the most up-to-date information available at the time of printing, minor updates may occur.

To find the latest information contact an Öhlins distributor. Please contact Öhlins if you have any questions regarding the contents in this document.

Part no. MI\_PI 301\_0  
Issued 2023-07-07

© Öhlins Asia Co. Ltd. All rights reserved. Any reprinting or unauthorized use without the written permission of Öhlins Racing AB is prohibited.

Öhlins Asia Co. Ltd  
700/937 Moo5, Tambol Nongkhaga,  
Amphur Phantong, Chonburi Province  
20160 Thailand



[www.ohlins.com](http://www.ohlins.com)