



**👁 Note!**

*Please note that this image is a general representation of the product and may differ slightly from your product.*

**👁 Note!**

*Please note that during storage and transportation, especially at high ambient temperature, some of the oil and grease used for assembling may leak and stain the packaging. This is in no way detrimental to the product, wipe off the excessive oil/grease with a cloth.*

**Kit Contents**

Description	Part No	Pcs
Shock absorber	HO414/417	1
Sticker Öhlins	00192-01	2
Seal ball joint	00534-02	4
Sticker memo notes	01180-01	1
Seal, ball joint	01218-54	4
Tool preload adj. cruis.	03199-03	1
Owner's Manual	07241-02	1

**⚠ Warning!**

*Before installing this product, read the Öhlins Owner's Manual. The shock absorber/front fork/steering damper is an important part of your vehicle and will affect the stability.*

**Shock absorber for Honda CB1300 & Kawasaki ZRX 1100**

**HO 414/ 417**

**Mounting Instructions**



# MOUNTING INSTRUCTIONS

## ⚠ Warning!

It is advisable to have an Öhlins dealer install the shock absorber/front fork/steering damper.

## ⚠ Warning!

If working on a raised vehicle, ensure it is securely supported so that it will not tip.

## 👁 Note!

Before mounting this product clean the vehicle thoroughly.

## 👁 Note!

When working on this product, always see the Vehicle Service Manual for vehicle specific procedures and important data.

1

Put the motorcycle on a workstand so that the rear wheel barely touches the ground.

2

Loosen and remove the original shock absorbers.

3

Mount the Öhlins shock absorber in the same position as the original shock absorber. The cylinder head up and the piggy back reservoir towards the rear. Use the seals and spacers supplied for the upper attachment.

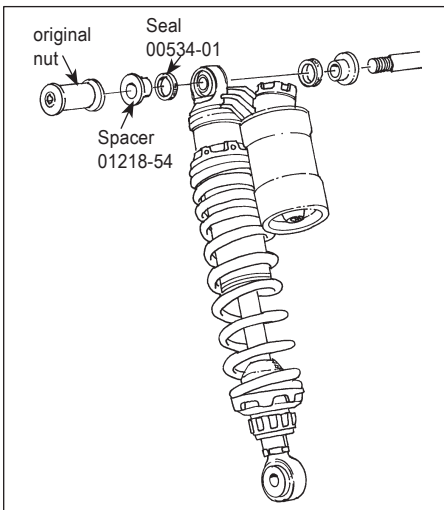

## 👁 Caution!

There is a left hand and a right hand shock absorber. The reservoir mount is slightly angled out, away from the wheel. If the shock absorbers are mounted with the reservoir angled towards the wheel, the shock absorber reservoirs can be damaged.

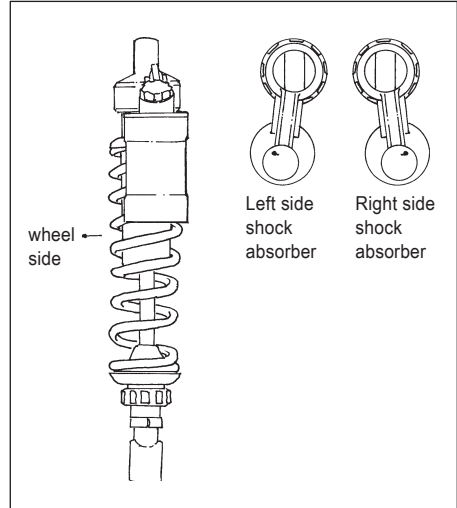

## 👁 Note!

Lower the vehicle so that the suspension is slightly compressed before tightening the screws.

## 👁 Caution!

Ensure that all screws are tightened to the correct torque and that nothing fouls or restricts movement of the shock absorber/front fork/steering damper when the suspension is fully compressed or extended.

# MOUNTING INSTRUCTIONS

# ADJUSTMENTS

## ⚠ Warning!

Before riding, always make sure that the basic settings made by Öhlins are according to recommended Set-up Data. Read about adjustments and setting up in the Öhlins Owner's Manual before you make any adjustments. Contact an Öhlins dealer if you have any questions about setting up.

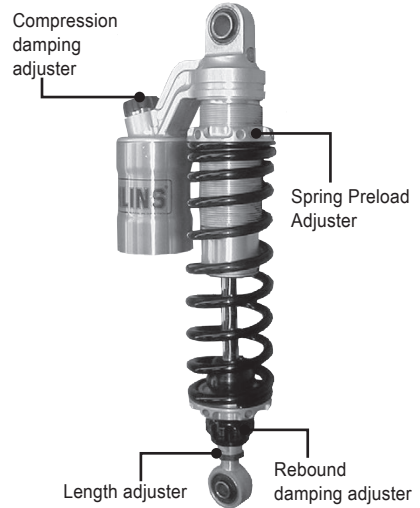

## SET-UP DATA

Length	365 <sup>+8/-2</sup>	mm
Stroke	92	mm
Rebound	20	clicks
Compression	15	clicks
Spring preload	21	mm

👁 Öhlins products are subject to continuous improvement and development, therefore, although these instructions include the most up-to-date information available at the time of printing, minor updates may occur.

To find the latest information contact an Öhlins distributor. Please contact Öhlins if you have any questions regarding the contents in this document.

Part no. MI\_HO414/417\_1  
Issued 2014-03-10

© Öhlins Racing AB. All rights reserved. Any reprinting or unauthorized use without the written permission of Öhlins Racing AB is prohibited.

Öhlins Racing AB  
Box 722  
S-194 27 Upplands Väsby, Sweden  
Phone +46 8 590 025 00  
fax +46 8 590 025 80



[www.ohlins.com](http://www.ohlins.com)