

Adjustments

⚠ Warning!

Before riding, always make sure that the basic settings made by Öhlins are according to recommended Set-up Data. Read about adjustments and setting up in the Öhlins Owner's Manual before you make any adjustments. Contact an Öhlins dealer if you have any questions about setting up the shock absorber.

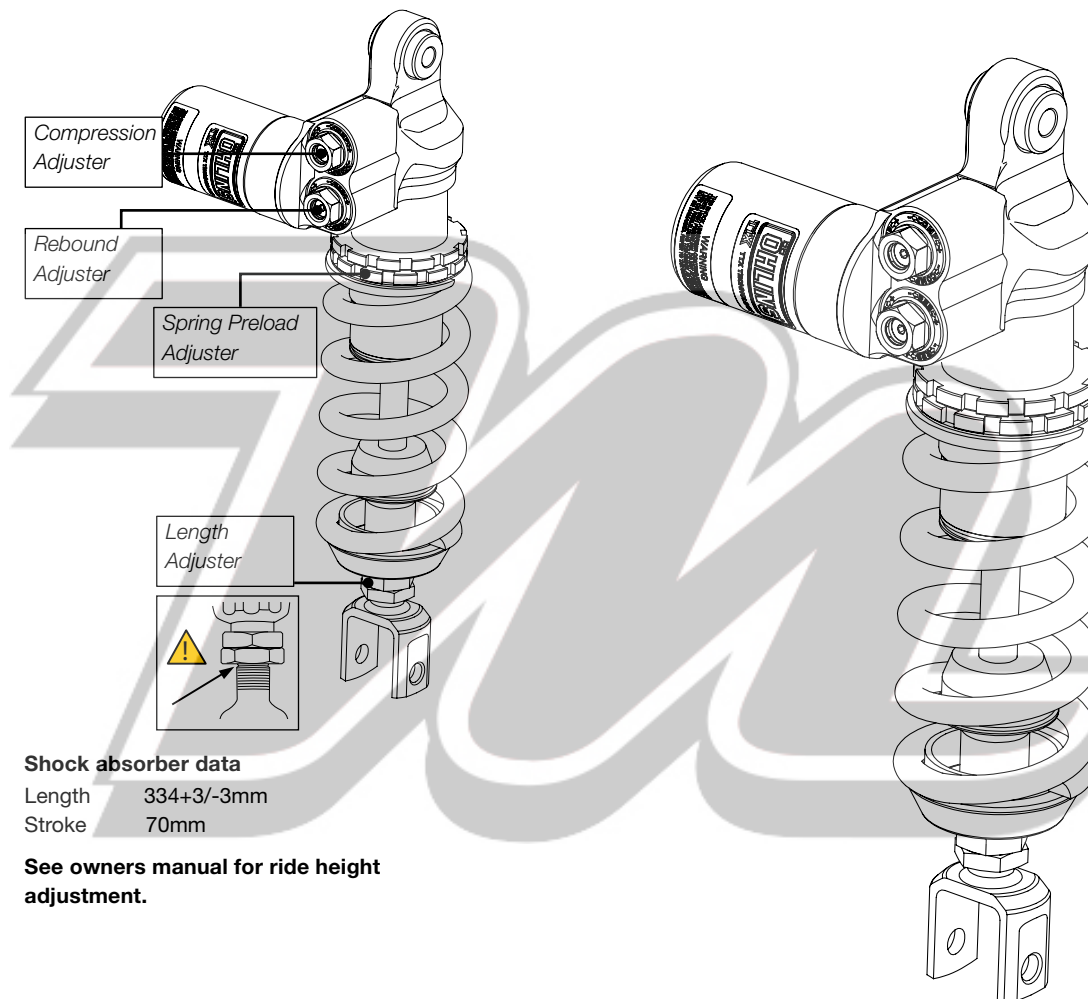

Before installing this product, check the contents of the kit. If anything is missing, please contact an Öhlins dealer.

Kit Contents

	Part No	Pcs
Shock absorber	KA 105	1
C-spanner single	00710-05	1
Öhlins Sticker	00192-01	2
Memo Notes Sticker	01180-01	1
Owner's Manual	07242-01	1

👁 Note!

Please note that during storage and transportation, especially at high ambient temperature, some of the oil and grease used for assembling may leak and stain the packaging. This is in no way detrimental to the product, wipe off the excessive oil/grease with a cloth.

⚠ Warning!

Before installing this product, read the Öhlins Owner's Manual. The shock absorber is an important part of your vehicle and will affect the stability.

Set-up Data

Recommended set-up

Rebound	12 clicks
Compression	10 clicks
Spring Preload	16 mm

Spring

Part No.	Rate
21040-24	80N/mm

Shock absorber data

Length	334+3/-3mm
Stroke	70mm

See owners manual for ride height adjustment.

👁 Öhlins products are subject to continuous improvement and development, therefore, although these instructions include the most up-to-date information available at the time of printing, minor updates may occur.

To find the latest information contact an Öhlins distributor. Please contact Öhlins if you have any questions regarding the contents in this document.

Part no. KA105
Issued 2011-03-31



© Öhlins Racing AB. All rights reserved. Any reprinting or unauthorized use without the written permission of Öhlins Racing AB is prohibited.

Öhlins Racing AB
Box 722
S-194 27 Upplands Väsby, Sweden
Phone +46 8 590 025 00
fax +46 8 590 025 80



www.ohlins.com

Shock Absorber for Kawasaki Z 750 R **KA 105**

Mounting Instructions



How to Install

⚠ Warning!

It is advisable to have an Öhlins dealer install the shock absorber.

⚠ Warning!

When installing, read your Vehicle Service Manual.

⚠ Warning!

Make sure the vehicle is securely supported so that it will not tip.

1

Put the motorcycle on a workstand so that the rear wheel barely touches the ground.

2

Loosen the pull rods of the suspension linkage at the swing arm, remove the upper and lower shock absorber attachment bolts.

3

Remove the original shock absorber.

👁 Note!

Before installing the Öhlins shock absorber clean the vehicle thoroughly.

4

Install the Öhlins shock absorber in the same way as the original unit. Do not tighten yet.

👁 Note!

Lower the motorcycle so that the shock absorber is slightly compressed, before tightening the screws.

5

Tighten the attachment bolts to correct torque according to Kawasaki specification.

👉 Caution!

Make sure that all screws are tightened to the correct torque and that nothing fouls or restricts movement of the shock absorber when the suspension is fully compressed or extended.

