



LP0341

**FITTING INSTRUCTIONS FOR LP0341BK**  
**LICENCE PLATE BRACKET**



**THIS KIT CONTAINS THE ITEMS PICTURED AND LABELLED OVER PAGE.**

SOME PARTS MAY BE SHOWN FOR CLARITY OF INSTRUCTIONS ONLY.

DO NOT PROCEED UNTIL YOU ARE SURE ALL PARTS ARE PRESENT.

**PLEASE READ ALL INSTRUCTIONS BEFORE PROCEEDING.**

**IF IN ANY DOUBT WHEN FITTING OUR PRODUCTS, CONSULT ONE OF OUR DEALERS OR  
HAVE FITTED BY A QUALIFIED TECHNICIAN.**

PLEASE NOTE THAT THE WAY THE KIT IS PACKED DOES NOT NECESSARILY REPRESENT THE WAY OF  
MOUNTING TO THE BIKE.

IN THE EVENT OF RUBBER WASHERS BEING USED TO HOLD COMPONENTS ONTO BOLTS,  
THESE RUBBER WASHERS CAN BE THROWN AWAY.

**DIGITAL COPIES OF THESE INSTRUCTIONS ARE AVAILABLE FROM:**

[WWW.RG-RACING.COM](http://WWW.RG-RACING.COM)



<b><u>TOOLS REQUIRED</u></b>	<b><u>GENERAL TORQUE SETTINGS</u></b>
<ul style="list-style-type: none"> <li>• Set of metric Allen Keys.</li> <li>• Flat head screwdriver</li> <li>• Set of metric spanners or ratchet with metric sockets.</li> <li>• Small amount of superglue.</li> <li>• Wire cutters</li> </ul>	<p>M4 BOLT = 8Nm</p> <p>M5 BOLT = 12Nm</p> <p>M6 BOLT = 15Nm</p> <p>M8 BOLT = 20Nm</p> <p>M10 BOLT = 40Nm</p>

**LEGEND**

<b>ITEM NO.</b>	<b>DESCRIPTION</b>	<b>QTY</b>
ITEM 1	TB0341 PART 1 - MAIN BRACKET	1
ITEM 2	TB0341 PART 2 - LICENSE PLATE MOUNT PLATE	1
ITEM 3	LA0002 - NUMBER PLATE LIGHT (W/SHROUD)	1
ITEM 4	CON0014 - LICENCE PLATE LIGHT ADAPTOR	1
ITEM 5	666-896/20 - 200mm LENGTH OF HEAT SHRINK	1
ITEM 6	FS0003BK - 100mm LENGTH OF SELF ADHESIVE FOAM	1
ITEM 7	CT75 - 2.5mm x 75mm CABLE TIE	3
ITEM 8	CLIP1 - SELF ADHESIVE CLIP	1
ITEM 9	REFL3 - REFLECTOR	1

**ASSEMBLY DIAGRAM**

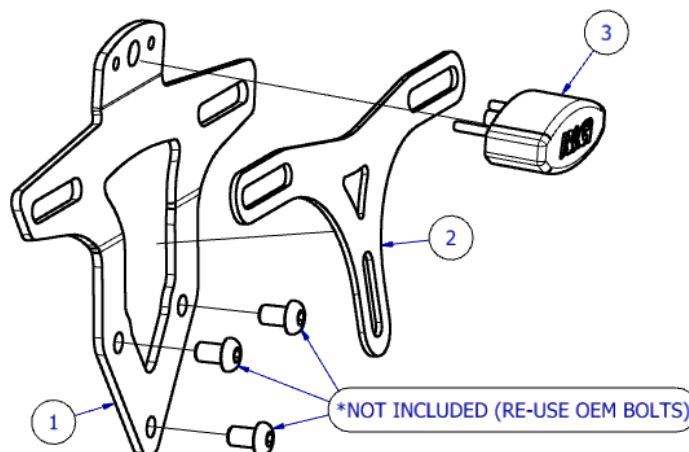



**FITTING PICTURES**

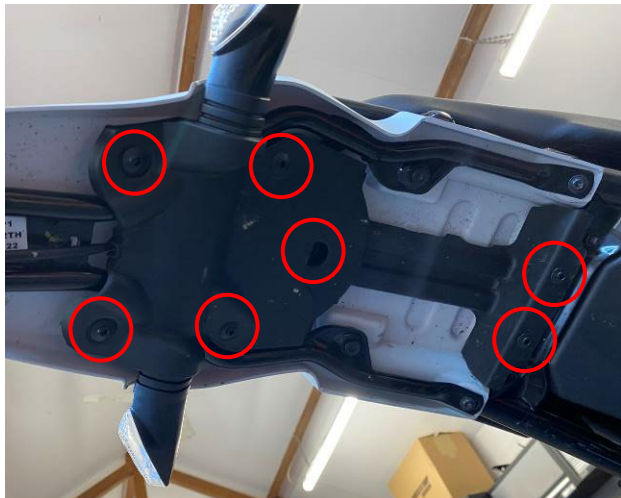

**Picture 1**

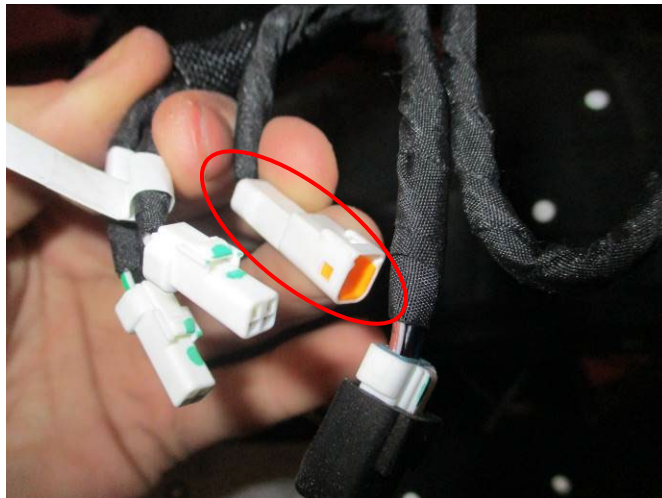

**Picture 2**

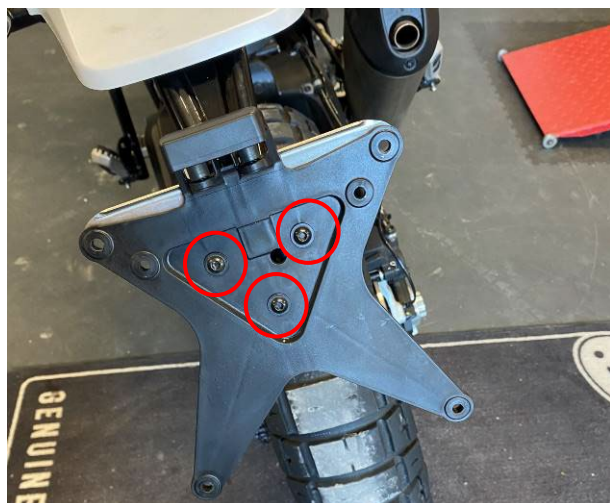

**Picture 3**



**Picture 4**



## **FITTING INSTRUCTIONS**

- Begin by disconnecting the OEM license plate illuminator. This connector for this can be found underneath the rear fender of the bike by removing the cable tidy plastic pieces as highlighted in **Picture 1**.
- The OEM license plate illuminator connector is highlighted in **Picture 2**.
- Remove the OEM license plate holder bracket by removing the 3 x bolts shown in **Picture 3**, keep these bolts to one side as you will re-use them when fitting the R&G replacement license plate bracket.
- Pre-assemble the R&G license plate holder as shown in **ASSEMBLY DIAGRAM** shown above.
- Install the length of heat-shrink (**item 5**) onto the license plate illuminator wires (**item 3**).
- Connect the CON0014 adaptor (**item 4**) to the LA0002 (**item 3**) bullet connectors, and then simply connect the remaining male connector from the CON0014 adaptor into the female connector which is shown in **Picture 2**.
- It is a good idea to now check the operation of the license plate illuminator (**item 3**) before fully installing this kit. If illumination fails, swap the bullet connectors around.
- Re-route the wiring as the OEM wiring was and use the self-adhesive clip and cable ties (**item 7**) provided to achieve a tidy finish.
- Secure the R&G license plate holder to the bike by using the 3 x OEM mounting bolts removed earlier as shown in **Picture 3**.
- To use the lower central license plate fixing, you must install the additional plate (**item 2**), simply place this between the license plate and the R&G licence plate holder, secure using the license plate mounting bolts which secure the plate to the plate holder. The lower centre bolt may need to be trimmed down to fit, this is achieved easily using wire cutters. Foam is provided to stop vibrations if necessary.
- **IMPORTANT: IF FITTING A FULL-SIZE LICENCE PLATE AND PLACING IT FAR DOWN ON THE LICENCE PLATE HANGER, THERE IS A SMALL CHANCE OF THE LICENCE PLATE HITTING THE BACK WHEEL UNDER HEAVY LOAD AND OVER LARGE BUMPS IN THE ROAD. IT IS YOUR RESPONSIBILITY TO CHECK FOR THIS POSSIBILITY AND TAKE AVOIDING ACTION. FAILURE TO CHECK THIS COULD RESULT IN SERIOUS INJURY.**
- Depending on local laws, attach enclosed reflector (**item 9**) in an appropriate location.
- Test the license plate illuminator and all lights before riding.

ISSUE 1 11/10/2022 (AO)

### **CONSUMER NOTICE**

The catalogue description and any exhibition of samples are only broad indications of the Products and R&G may make design changes which do not diminish their performance or visual appeal and supplying them in such state shall conform to the order. The Buyer acknowledges no representation or warranty (other than as to title) has been given or will apply to the Products other than those in R&G's order or confirmation and the Buyer confirms it has chosen the Products as being of merchantable quality and suitable for its particular purposes. Where R&G fits the Products or undertakes other services it shall exercise reasonable skill and care and rectify any fault free of charge unless the workmanship has been disturbed. The Buyer is responsible for ensuring that the warranty on the motorcycle is not affected by the fitting of the Products. On return of any defective Products R&G shall at its option either supply a replacement or refund the purchase money but shall not be liable if the Products have been modified or used or maintained otherwise than in accordance with R&G's or manufacturer's instructions and good engineering practice or if the defect arises from accident or neglect. Other than identified above and subject to R&G not limiting its liability for causing death and personal injury, it shall not be liable for indirect or consequential loss and otherwise its liability shall be limited to the amounts paid by the Buyer for the Products or the fitting or service concerned. These terms do not affect the Buyer's statutory rights.

### **R&G RETURNS POLICY (NON-FAULTY GOODS)**

Returns must be pre-authorized (if not pre-authorized the return will be rejected). Goods may only be returned direct to us if they were purchased direct from us (customer must prove if necessary). Otherwise to be returned to original vendor. Goods must be in re-sellable condition, in the opinion of R&G. All returns are subject to a 25% restocking and handling fee (25% of the gross value exc. P&P - at the prevailing price at time of purchase). The customer must pay any and all carriage charges. No returns of discontinued products, unless within 14 days of purchase. This policy does not affect your statutory rights and does not refer to faulty goods.

R&G, Unit 1, Shelley's Lane, East Worldham, Alton, Hampshire, GU34 3AQ

Tel: +44 (0)1420 89007 Fax: +44 (0)1420 87301 [www.rg-racing.com](http://www.rg-racing.com) Email: [info@rg-racing.com](mailto:info@rg-racing.com)



LP0341

**NOTICE DE MONTAGE LP0341BK**  
**SUPPORT DE PLAQUE**



**CE KIT CONTIENT LES ARTICLES ILLUSTRÉS ET ÉTIQUETES SUR LA PAGE.**

CERTAINES PARTIES PEUVENT ÊTRE PRÉSENTES UNIQUEMENT POUR LA CLARTÉ DES INSTRUCTIONS.

NE PAS PROCÉDER AU MONTAGE TANT QUE VOUS N'ÊTES PAS SÛR QUE TOUTES LES PIÈCES SOIENT PRÉSENTES.

**VEUILLEZ LIRE TOUTES LES INSTRUCTIONS AVANT DE CONTINUER.**

**EN CAS DE DOUTE LORS DU MONTAGE DE NOS PRODUITS, CONSULTEZ UN DE NOS  
REVENDEURS OU FAITES APPEL À UN TECHNICIEN QUALIFIÉ.**

VEUILLEZ NOTER QUE LA FAÇON DONT LE KIT EST EMBALLÉ NE REPRÉSENTE PAS NECESSAIREMENT LA  
MANIÈRE DE LE MONTER SUR LA MOTO.

SI DES RONDELLES EN CAOUTCHOUC SONT UTILISÉES POUR MAINTENIR LES COMPOSANTS SUR LES  
BOULONS, ELLES PEUVENT ÊTRE JETÉES.

**NOTICE DISPONIBLE AU TÉLÉCHARGEMENT SUR :**  
[WWW.RG-RACING.COM](http://WWW.RG-RACING.COM)





<b><u>OUTILS REQUIS</u></b>	<b><u>VALEURS DE SERRAGE</u></b>
<ul style="list-style-type: none"> <li>• Clés Allen.</li> <li>• Tournevis plat</li> <li>• Clé à cliquet + douilles.</li> <li>• Un peu de superglue.</li> <li>• Coupe câble</li> </ul>	<p>M4 BOULON = 8Nm</p> <p>M5 BOULON = 12Nm</p> <p>M6 BOULON = 15Nm</p> <p>M8 BOULON = 20Nm</p> <p>M10 BOULON = 40Nm</p> <p>M12 BOULON = 40Nm</p>

**LÉGENDE**

<b>ARTICLE NO.</b>	<b>DESCRIPTION</b>	<b>QTÉ</b>
ARTICLE 1	TB0341 PARTIE 1 – SUPPORT PRINCIPAL	1
ARTICLE 2	TB0341 PARTIE 2 – PLAQUE DE SUPPORT DE PLAQUE	1
ARTICLE 3	LA0002 – FEU DE PLAQUE (W/PROTECTION)	1
ARTICLE 4	CON0014 – ADAPTATEUR DE FEU DE PLAQUE	1
ARTICLE 5	666-896/20 – 200mm THERMO RÉTRACTABLE	1
ARTICLE 6	FS0003BK – 100mm BANDEAU DE MOUSSE ADHÉSIF	1
ARTICLE 7	CT75 – 2.5mm x 75mm COLLIER DE SERRAGE	3
ARTICLE 8	CLIP1 – CLIP AUTOCOLLANT	1
ARTICLE 9	REFL3 - RÉFLECTEUR	1

**SCHÉMA D'ASSEMBLAGE**

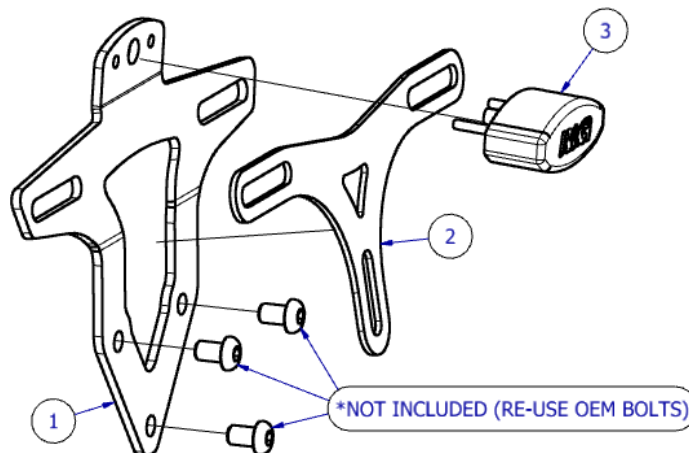



**PHOTOS DE MONTAGE**

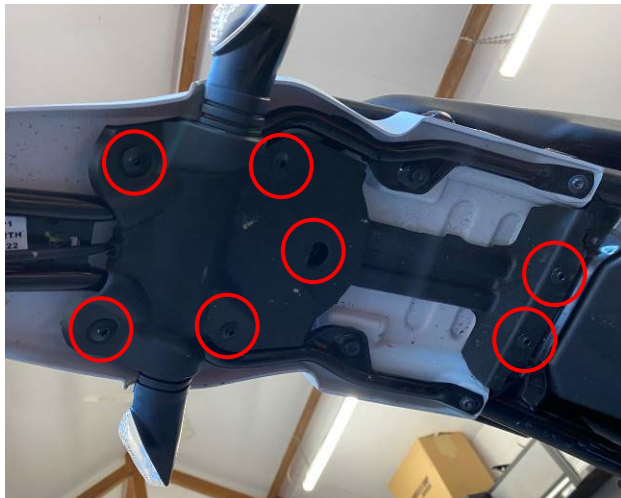

**Photo 1**

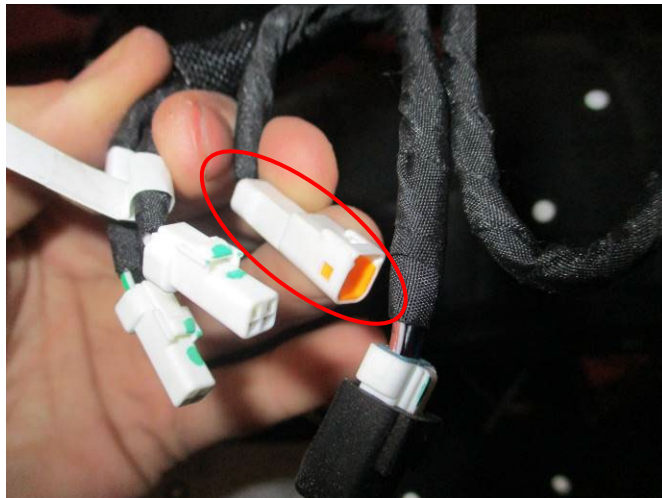

**Photo 2**

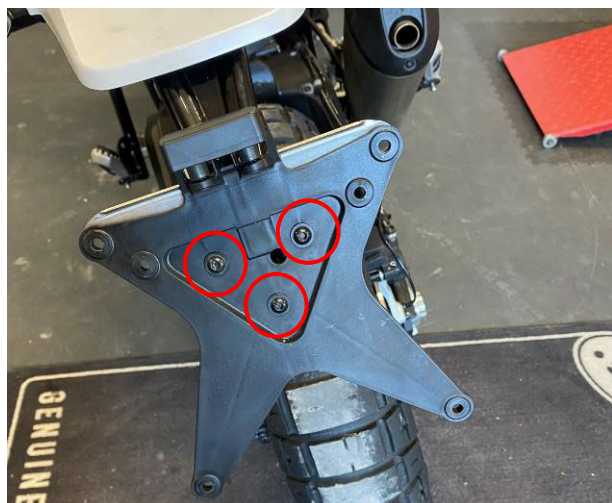

**Photo 3**



**Photo 4**



## **Notice de montage**

- Commencez par déconnecter le feu de plaque d'immatriculation d'origine. Ce connecteur pour cela peut être trouvé sous le garde-boue arrière du vélo en retirant les pièces en plastique de rangement des câbles comme indiqué sur la photo 1.
- Le connecteur de feu de plaque d'immatriculation d'origine est mis en évidence sur la photo 2.
- Retirez le support de support de plaque d'immatriculation d'origine en retirant les 3 boulons illustrés sur la photo 3, gardez ces boulons de côté car vous les réutiliserez lors du montage du support de plaque d'immatriculation de remplacement R&G.
- Pré-assemblez le support de plaque d'immatriculation R&G comme indiqué sur le SCHÉMA D'ASSEMBLAGE ci-dessus.
- Installez la longueur de gaine thermo rétractable (article 5) sur les fils de feu de la plaque d'immatriculation (article 3).
- Connectez l'adaptateur CON0014 (article 4) aux connecteurs LA0002 (article 3), puis connectez simplement le connecteur mâle restant de l'adaptateur CON0014 dans le connecteur femelle qui est montré sur la Photo 2.
- Il est conseillé de vérifier maintenant le fonctionnement du feu de plaque d'immatriculation (article 3) avant d'installer complètement ce kit. Si l'éclairage échoue, permutez les connecteurs.
- Redirigez le câblage comme l'était le câblage d'origine et utilisez le clip auto-adhésif et les attaches de câble (article 7) fournis pour obtenir une finition soignée.
- Fixez le support de plaque d'immatriculation R&G à la moto en utilisant les 3 boulons de montage d'origine retirés précédemment, comme indiqué sur la photo 3
- Pour utiliser la fixation centrale inférieure de la plaque d'immatriculation, vous devez installer la plaque supplémentaire (article 2), placez-la simplement entre la plaque d'immatriculation et le support de plaque d'immatriculation R&G, fixez-la à l'aide des boulons de fixation de la plaque d'immatriculation qui fixent la plaque au support de plaque. Le boulon central inférieur peut avoir besoin d'être coupé pour s'adapter, ceci est réalisé facilement à l'aide de pinces coupantes. De la mousse est fournie pour stopper les vibrations si nécessaire.
- **IMPORTANT : SI VOUS MONTEZ UNE PLAQUE D'IMMATRICULATION LARGE ET QUE VOUS LA PLACEZ ASSEZ BASSE SUR LE SUPPORT DE PLAQUE D'IMMATRICULATION, IL EST POSSIBLE QUE LA PLAQUE D'IMMATRICULATION TOUCHE LA ROUE ARRIÈRE SOUS UNE CHARGE LOURDE ET SUR DE GROSSES BOSSES SUR LA ROUTE. IL EST DE VOTRE RESPONSABILITÉ DE VÉRIFIER CETTE POSSIBILITÉ ET DE PRENDRE DES MESURES POUR ÉVITER. NE PAS VÉRIFIER CELA POURRAIT ENTRAÎNER DES BLESSURES GRAVES.**
- En fonction des lois locales, fixez le réflecteur fourni (article 9) à un endroit approprié.
- Testez le fonctionnement de tous les feux avant de rouler.

ISSUE 1 11/10/2022 (AO)

### **CONSUMER NOTICE**

The catalogue description and any exhibition of samples are only broad indications of the Products and R&G may make design changes which do not diminish their performance or visual appeal and supplying them in such state shall conform to the order. The Buyer acknowledges no representation or warranty (other than as to title) has been given or will apply to the Products other than those in R&G's order or confirmation and the Buyer confirms it has chosen the Products as being of merchantable quality and suitable for its particular purposes. Where R&G fits the Products or undertakes other services it shall exercise reasonable skill and care and rectify any fault free of charge unless the workmanship has been disturbed. The Buyer is responsible for ensuring that the warranty on the motorcycle is not affected by the fitting of the Products. On return of any defective Products R&G shall at its option either supply a replacement or refund the purchase money but shall not be liable if the Products have been modified or used or maintained otherwise than in accordance with R&G's or manufacturer's instructions and good engineering practice or if the defect arises from accident or neglect. Other than identified above and subject to R&G not limiting its liability for causing death and personal injury, it shall not be liable for indirect or consequential loss and otherwise its liability shall be limited to the amounts paid by the Buyer for the Products or the fitting or service concerned. These terms do not affect the Buyer's statutory rights.





LP0341

**R&G RETURNS POLICY (NON-FAULTY GOODS)**

Returns must be pre-authorized (if not pre-authorized the return will be rejected). Goods may only be returned direct to us if they were purchased direct from us (customer must prove if necessary). Otherwise to be returned to original vendor. Goods must be in re-sellable condition, in the opinion of R&G. All returns are subject to a 25% restocking and handling fee (25% of the gross value exc. P&P – at the prevailing price at time of purchase). The customer must pay any and all carriage charges. No returns of discontinued products, unless within 14 days of purchase. This policy does not affect your statutory rights and does not refer to faulty goods.