



FITTING INSTRUCTIONS FOR LP0325 LICENCE PLATE BRACKET
KTM 390 ADVENTURE 2020-



**This kit contains the items pictured and labelled over page.
Some parts may be shown for clarity of instructions only.
Do not proceed until you are sure all parts are present.
Please read all instructions before proceeding.**

**IF IN ANY DOUBT WHEN FITTING OUR PRODUCTS, CONSULT ONE OF OUR DEALERS
OR HAVE FITTED BY A QUALIFIED TECHNICIAN.**

Please note that the way the kit is packed does not necessarily represent the way of mounting to the bike.

In the event of rubber washers being used to hold components onto bolts, these rubber washers can be thrown away.

DIGITAL COPIES OF THESE INSTRUCTIONS ARE AVAILABLE FROM

WWW.RG-RACING.COM

R&G

Unit 1, Shelley's Lane, East Worldham, Alton, Hampshire, GU34 3AQ
Tel: +44 (0)1420 89007 Fax: +44 (0)1420 87301 www.rg-racing.com Email: info@rg-racing.com



<u>TOOLS REQUIRED</u>	<u>GENERAL TORQUE SETTINGS</u>
<ul style="list-style-type: none"> • Set of metric Allen keys to include 3, 4, 5 & 6mm • 12mm spanner or socket. • Phillips screwdriver. • Small flat head screwdriver. 	<p>M4 BOLT = 8Nm</p> <p>M5 BOLT = 12Nm</p> <p>M6 BOLT = 15Nm</p> <p>M8 BOLT = 20Nm</p> <p>M10 BOLT = 40Nm</p> <p>M12 BOLT = 40Nm</p>

LEGEND

ITEM No.	DESCRIPTION	QTY
ITEM 1	TB0325 - TAIL BRACKET	1
ITEM 2	M6x35mm BUTTON HEAD BOLTS	4
ITEM 3	M6 WASHERS	4
ITEM 4	IWC0002 MINI INDICATOR WIRING COVERS	2
ITEM 5	150mm LENGTH OF HEAT SHRINK	2
ITEM 6	2.5mm CABLE TIES 220mm LONG	2
ITEM 7	REFL 3 - REFLECTOR	1
ITEM 8	MINI INDICATOR BLANKING GROMMET	2
ITEM 9	CON013 MINI INDICATOR CONNECTORS	2

R&G

Unit 1, Shelley's Lane, East Worldham, Alton, Hampshire, GU34 3AQ

Tel: +44 (0)1420 89007 Fax: +44 (0)1420 87301 www.rg-racing.com Email: info@rg-racing.com



ASSEMBLY DIAGRAM

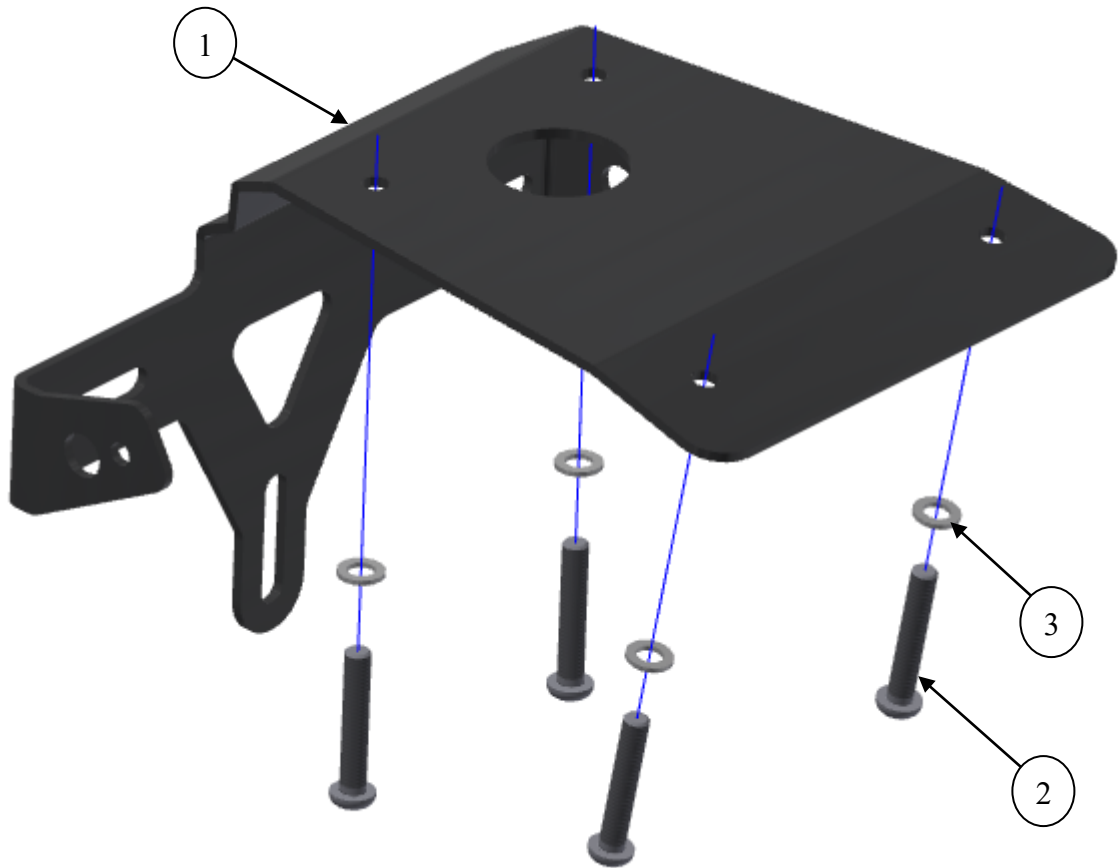



FITTING PICTURES



Picture 1



Picture 2



Picture 3

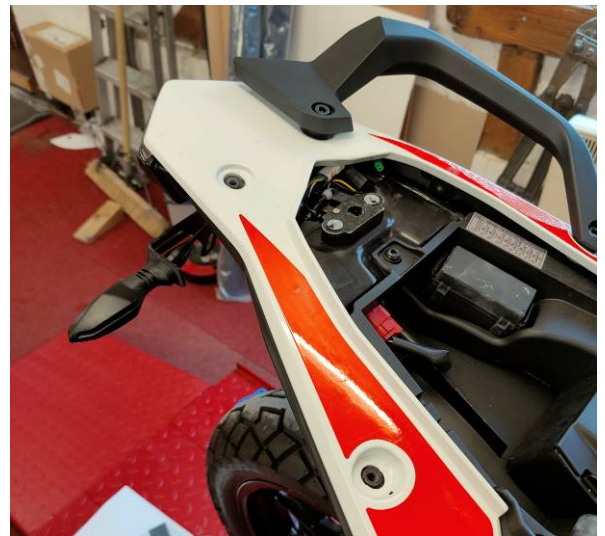

Picture 4

R&G

Unit 1, Shelley's Lane, East Worldham, Alton, Hampshire, GU34 3AQ

Tel: +44 (0)1420 89007 Fax: +44 (0)1420 87301 www.rg-racing.com Email: info@rg-racing.com



Picture 5



Picture 6



Picture 7

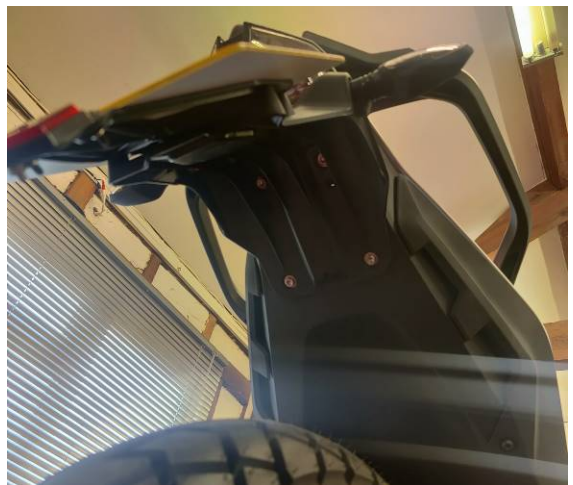

Picture 8

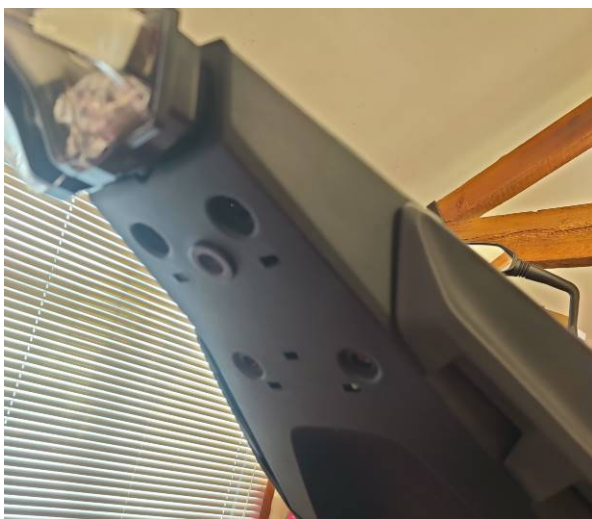



Picture 9



Picture 10



Picture 11



Picture 12

Picture 13



FITTING INSTRUCTIONS

- Use the key to remove the seat unit as shown in **Pictures 1 & 2**.
- Remove the rear grab rails using a 6mm Allen Key as shown in **Pictures 3 & 4**.
- Next remove the rear body panel using a 5mm Allen Key by removing the screw shown in **Picture 6** on both sides.
- Now that the wiring is exposed, the indicators can be disconnected before the OEM license plate bracket is removed. Make note of which wires lead to the left and right indicators so that they can be reconnected correctly.
- Remove the 4 bolts shown in **Picture 8** which secure the OEM license plate bracket to the bike.
- The OEM license plate bracket can then be gently pulled and unclipped from the bike. Carefully feed the indicator wires through the rubber grommet.

R&G

Unit 1, Shelley's Lane, East Worldham, Alton, Hampshire, GU34 3AQ

Tel: +44 (0)1420 89007 Fax: +44 (0)1420 87301 www.rg-racing.com Email: info@rg-racing.com



- With the OEM license plate bracket removed from the bike, the OEM indicators can be removed with a 12mm spanner. See **Picture 10**.
- If re-using the OEM indicators these can be attached to the R&G tail bracket.
- If using R&G mini or other aftermarket indicators, these can be attached instead, but the connector wire must be attached in order to interface with the OEM wiring loom.
- The wires then need to be fed back through the rubber grommet as shown in **Picture 12**.
- The R&G tail bracket can then be secured using the 4 M6 bolts and washers provided as shown in **Picture 13**.
- The indicators can then be reconnected to the bike's wiring loom and any exposed cables tidied with the cable ties provided. Ensure that the indicators flash correctly.
- Re-fit the rear body panel, grab rails and seat.

IMPORTANT: IF FITTING A FULL-SIZE LICENCE PLATE AND PLACING IT FAR DOWN ON THE LICENCE PLATE HANGER, THERE IS A SMALL CHANCE OF THE LICENCE PLATE HITTING THE BACK WHEEL UNDER HEAVY LOAD AND OVER LARGE BUMPS IN THE ROAD. IT IS YOUR RESPONSIBILITY TO CHECK FOR THIS POSSIBILITY AND TAKE AVOIDING ACTION. FAILURE TO CHECK THIS COULD RESULT IN SERIOUS INJURY.

ISSUE 1 - 20/09/2021 - (WW)

CONSUMER NOTICE

The catalogue description and any exhibition of samples are only broad indications of the Products and R&G may make design changes which do not diminish their performance or visual appeal and supplying them in such state shall conform to the order. The Buyer acknowledges no representation or warranty (other than as to title) has been given or will apply to the Products other than those in R&G's order or confirmation and the Buyer confirms it has chosen the Products as being of merchantable quality and suitable for its particular purposes. Where R&G fits the Products or undertakes other services it shall exercise reasonable skill and care and rectify any fault free of charge unless the workmanship has been disturbed. The Buyer is responsible for ensuring that the warranty on the motorcycle is not affected by the fitting of the Products. On return of any defective Products R&G shall at its option either supply a replacement or refund the purchase money but shall not be liable if the Products have been modified or used or maintained otherwise than in accordance with R&G's or manufacturer's instructions and good engineering practice or if the defect arises from accident or neglect. Other than identified above and subject to R&G not limiting its liability for causing death and personal injury, it shall not be liable for indirect or consequential loss and otherwise its liability shall be limited to the amounts paid by the Buyer for the Products or the fitting or service concerned. These terms do not affect the Buyer's statutory rights.

R&G RACING RETURNS POLICY (NON-FAULTY GOODS)

Returns must be pre-authorized (if not pre-authorized the return will be rejected). Goods may only be returned direct to us if they were purchased direct from us (customer must prove if necessary). Otherwise to be returned to original vendor. Goods must be in re-sellable condition, in the opinion of R&G Racing. All returns are subject to a 25% restocking and handling fee (25% of the gross value exc. P&P – at the prevailing price at time of purchase). The customer must pay any and all carriage charges. No returns of discontinued products, unless within 14 days of purchase. This policy does not affect your statutory rights and does not refer to faulty goods.

R&G

Unit 1, Shelley's Lane, East Worldham, Alton, Hampshire, GU34 3AQ

Tel: +44 (0)1420 89007 Fax: +44 (0)1420 87301 www.rg-racing.com Email: info@rg-racing.com



MONTAGEANLEITUNG FÜR LP0325 KENNZEICHENHALTER
KTM 390 ADVENTURE 2020-



Alle Kit-Teile sind auf den nachfolgenden Seiten abgebildet und gekennzeichnet.

Die abgebildeten Teile dienen lediglich zur Erklärung.

Überprüfen Sie zuerst, dass alle Teile vorhanden sind.

Lesen Sie die Montageanleitung komplett durch, bevor Sie anfangen.

WENN SIE BEI DER MONTAGE DIESES PRODUKTES UNSICHER SIND, BITTE EINEN UNSERER HÄNDLER KONTAKTIEREN ODER DAS KIT VON EINEM QUALIFIZIERTEN ZWEIRAD-MECHANIKER MONTIEREN LASSEN.

Die Verpackung der Teile stellt nicht die Reihenfolge der Montage dar.

Hinweis für Kits mit Plastikunterlegscheiben an den Schrauben –
Diese Plastik-Unterlegscheiben werden nicht für den Einbau benötigt

EINE DIGITALE VERSION DIESER MONTAGEANLEITUNG KANN AUF FOLGENDER SEITE HERUNTERGELADEN WERDEN:

WWW.RG-RACING.COM

R&G

Unit 1, Shelley's Lane, East Worldham, Alton, Hampshire, GU34 3AQ
Tel: +44 (0)1420 89007 Fax: +44 (0)1420 87301 www.rg-racing.com Email: info@rg-racing.com



<u>SIE BENÖTIGEN FOLGENDES WERKZEUG</u>	<u>ALLGEM. ANZUGSDREHMOMENTE</u>
<ul style="list-style-type: none"> • Satz Inbusschlüssel inkl. 4mm, 5mm & 6mm • 12mm Steckschlüssel oder Schraubenschlüssel • Kreuzschlitzschraubenzieher • kl. Flachklingen-Schraubenzieher 	<p>M4 SCHRAUBE = 8Nm</p> <p>M5 SCHRAUBE = 12Nm</p> <p>M6 SCHRAUBE = 15Nm</p> <p>M8 SCHRAUBE = 20Nm</p> <p>M10 SCHRAUBE = 40Nm</p> <p>M12 SCHRAUBE = 40Nm</p>

LIEFERUMFANG

ARTIKEL NR.	BESCHREIBUNG	MENGE
ARTIKEL 1	TB0325 - KENNZEICHENHALTER	1
ARTIKEL 2	M6x35mm INBUSSCHRAUBE	4
ARTIKEL 3	M6 UNTERLEGSCHLEIBE	4
ARTIKEL 4	IWC0002 MINIBLINKER KABEL-ABDECKUNG	2
ARTIKEL 5	150mm SCHRUMPFSCHLAUCH	2
ARTIKEL 6	2.5mm KABELBINDER 220mm	2
ARTIKEL 7	REFL 3 - RÜCKSTRAHLER	1
ARTIKEL 8	MINIBLINKER - GUMMITÜLLE	2
ARTIKEL 9	CON013 VERBINDUNG MINIBLINKER	2

R&G

Unit 1, Shelley's Lane, East Worldham, Alton, Hampshire, GU34 3AQ

Tel: +44 (0)1420 89007 Fax: +44 (0)1420 87301 www.rg-racing.com Email: info@rg-racing.com



ZUSAMMENBAU ZEICHNUNG

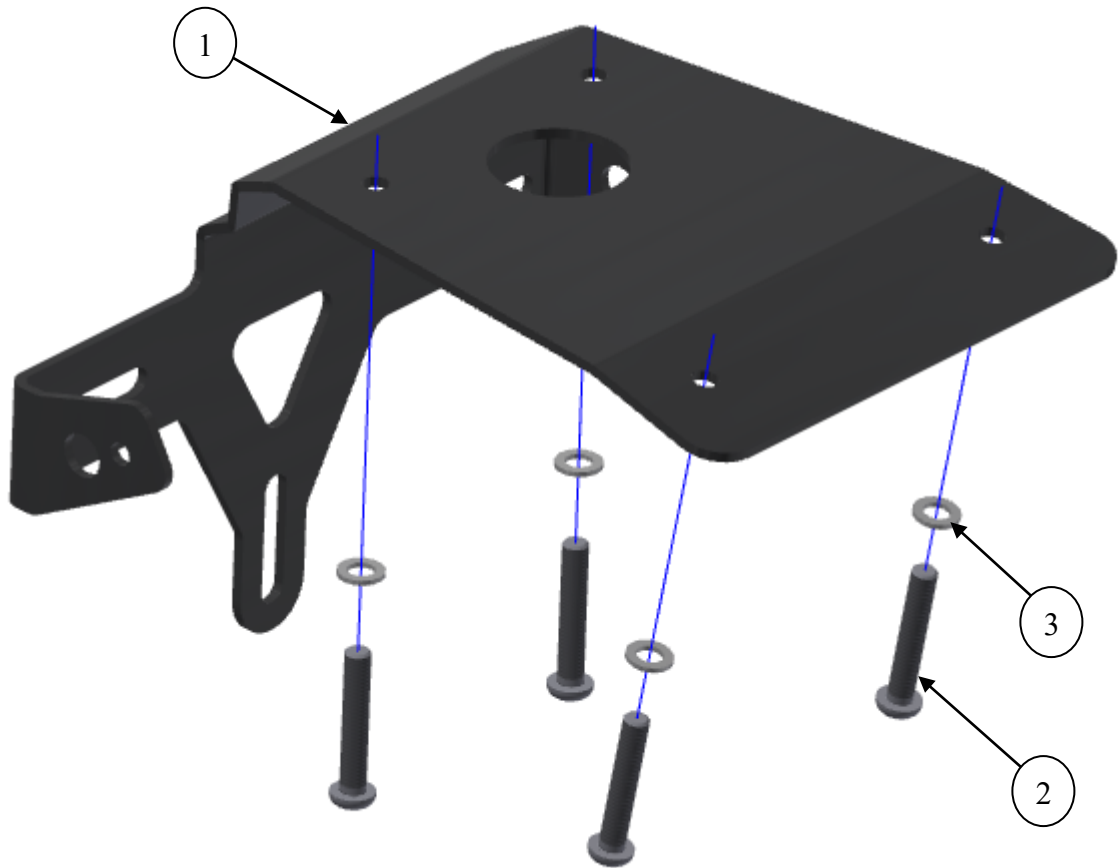

R&G

Unit 1, Shelley's Lane, East Worldham, Alton, Hampshire, GU34 3AQ

Tel: +44 (0)1420 89007 Fax: +44 (0)1420 87301 www.rg-racing.com Email: info@rg-racing.com



MONTAGE ABILDUNGEN



Abbildung 1



Abbildung 2



Abbildung 3



Abbildung 4

R&G

Unit 1, Shelley's Lane, East Worldham, Alton, Hampshire, GU34 3AQ

Tel: +44 (0)1420 89007 Fax: +44 (0)1420 87301 www.rg-racing.com Email: info@rg-racing.com

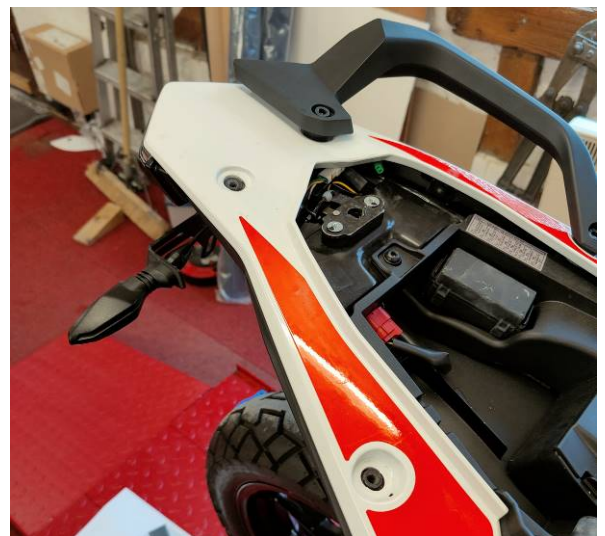

Abbildung 5



Abbildung 6



Abbildung 7



Abbildung 8



R&G

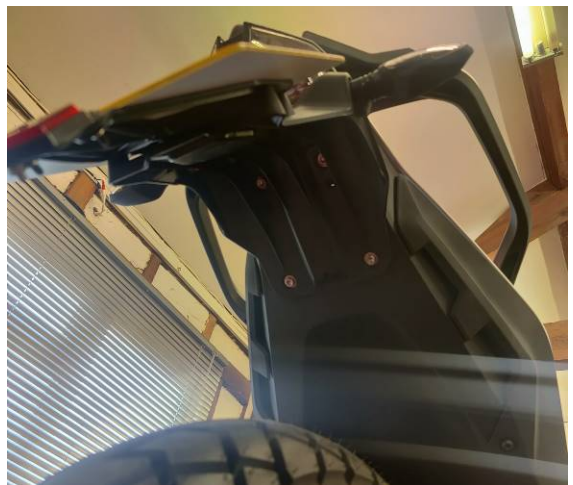
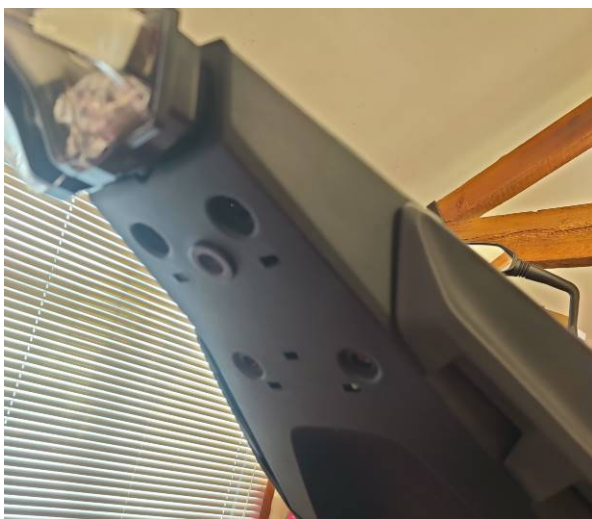

Abbildung 9



Abbildung 10



Abbildung 11



Abbildung 12

Abbildung 13

MONTAGEANLEITUNG

- Benutzen Sie den Schlüssel, um die Sitzeinheit zu entfernen wie in den **Abbildungen 1 & 2** abgebildet.
- Entfernen Sie die hinteren Haltegriffe mit einem 6mm Inbusschlüssel wie in den **Abbildungen 3 & 4** abgebildet.
- Nun entfernen Sie das hintere Verkleidungsteil, indem Sie an beiden Seiten die Schraube mit einem 5mm Inbusschlüssel entfernen – siehe **Abbildung 6**.
- Die Blinker können getrennt werden, bevor der original Kennzeichenhalter entfernt wird. Notieren Sie die die Verlegung der Kabel für die rechte und linke Seite, sodass sie später wieder richtig verbunden werden können.

R&G

Unit 1, Shelley's Lane, East Worldham, Alton, Hampshire, GU34 3AQ

Tel: +44 (0)1420 89007 Fax: +44 (0)1420 87301 www.rg-racing.com Email: info@rg-racing.com



- Entfernen Sie die 4 Schrauben, die den original Kennzeichenhalter am Motorrad befestigen (siehe **Abbildung 8**).
- Der original Kennzeichenhalter kann nun vorsichtig vom Motorrad weggezogen und entriegelt werden. Die Kabel für die Blinker vorsichtig durch die Gummitülle schieben.
- Sobald der original Kennzeichenhalter vom Motorrad entfernt ist, können die Originalblinker mit einem 12mm Schraubenschlüssel entfernt werden (siehe **Abbildung 10**).
- Wenn Sie die Originalblinker wiederverwenden, diese nun am R&G Kennzeichenhalter anbringen.
- Wenn Sie R&G Miniblinker oder Blinker aus dem Zubehörmarkt anbringen wollen, können diese montiert nun werden, aber die Verbindung für die Kabel muss montiert werden, um alles mit dem original Kabelbaum verbinden zu können.
- Die Kabel müssen anschließend durch die Gummitülle geführt werden wie in **Abbildung 12** abgebildet.
- Den R&G Kennzeichenhalter mit den vier M6 Schrauben und Unterlegscheiben vom Kit befestigen wie in **Abbildung 13** abgebildet.
- Die Blinker können dann wieder mit dem Motorrad-Kabelbaum verbunden werden und die Kabel mit den Kabelbindern vom Kit ordentlich fixiert. Stellen Sie sicher, dass die Blinker ordnungsgemäß funktionieren und blinken.
- Montieren Sie die Heckverkleidung, Haltegriffe und den Sitz wie ursprünglich wieder.

WICHTIG:

WENN SIE EIN GROSSES KENNZEICHEN ZU WEIT NACH UNTEN MONTIEREN BESTEHT BEI SCHWERER LAST ODER DURCH GROSSE BODENWELLEN EIN GERINGES RISIKO, DASS DAS KENNZEICHEN AN DAS HINTERRAD STOSSEN KANN. ES LIEGT IN IHRER VERANTWORTUNG DIES ZU ÜBERPRÜFEN UND, WENN NOTWENDIG, ZU VORBEUGENDE MASSNAHMEN ZU ERGREIFEN. DIE NICHTBEACHTUNG DIESES SICHERHEITSHINWEIS KANN ZU SCHWEREN VERLETZUNGEN FÜHREN.

AUSGABE 1 - 20/09/2021 - (WW)

CONSUMER NOTICE

The catalogue description and any exhibition of samples are only broad indications of the Products and R&G may make design changes which do not diminish their performance or visual appeal and supplying them in such state shall conform to the order. The Buyer acknowledges no representation or warranty (other than as to title) has been given or will apply to the Products other than those in R&G's order or confirmation and the Buyer confirms it has chosen the Products as being of merchantable quality and suitable for its particular purposes. Where R&G fits the Products or undertakes other services it shall exercise reasonable skill and care and rectify any fault free of charge unless the workmanship has been disturbed. The Buyer is responsible for ensuring that the warranty on the motorcycle is not affected by the fitting of the Products. On return of any defective Products R&G shall at its option either supply a replacement or refund the purchase money but shall not be liable if the Products have been modified or used or maintained otherwise than in accordance with R&G's or manufacturer's instructions and good engineering practice or if the defect arises from accident or neglect. Other than identified above and subject to R&G not limiting its liability for causing death and personal injury, it shall not be liable for indirect or consequential loss and otherwise its liability shall be limited to the amounts paid by the Buyer for the Products or the fitting or service concerned. These terms do not affect the Buyer's statutory rights.

R&G RACING RETURNS POLICY (NON-FAULTY GOODS)

Returns must be pre-authorized (if not pre-authorized the return will be rejected). Goods may only be returned direct to us if they were purchased direct from us (customer must prove if necessary). Otherwise to be returned to original vendor. Goods must be in re-sellable condition, in the opinion of R&G Racing. All returns are subject to a 25% restocking and handling fee (25% of the gross value exc. P&P – at the prevailing price at time of purchase). The customer must pay any and all carriage charges. No returns of discontinued products, unless within 14 days of purchase. This policy does not affect your statutory rights and does not refer to faulty goods.

R&G

Unit 1, Shelley's Lane, East Worldham, Alton, Hampshire, GU34 3AQ

Tel: +44 (0)1420 89007 Fax: +44 (0)1420 87301 www.rg-racing.com Email: info@rg-racing.com



NOTICE DE MONTAGE POUR LP0325 SUPPORT DE PLAQUE
KTM 390 ADVENTURE 2020-



CE KIT CONTIENT LES ARTICLES ILLUSTRÉS ET ÉTIQUETES SUR LA PAGE.

CERTAINES PARTIES PEUVENT ÊTRE PRÉSENTES UNIQUEMENT POUR LA CLARTÉ DES INSTRUCTIONS.

NE PAS PROCÉDER AU MONTAGE TANT QUE VOUS N'ÊTES PAS SÛR QUE TOUTES LES PIÈCES SOIENT PRÉSENTES.

VEUILLEZ LIRE TOUTES LES INSTRUCTIONS AVANT DE CONTINUER.

EN CAS DE DOUTE LORS DU MONTAGE DE NOS PRODUITS, CONSULTEZ UN DE NOS REVENDEURS OU FAITES APPEL À UN TECHNICIEN QUALIFIÉ.

VEUILLEZ NOTER QUE LA FAÇON DONT LE KIT EST EMBALLÉ NE REPRÉSENTE PAS NECESSAIREMENT LA MANIÈRE DE LE MONTER SUR LA MOTO.

SI DES RONDELLES EN CAOUTCHOUC SONT UTILISÉES POUR MAINTENIR LES COMPOSANTS SUR LES BOULONS, ELLES PEUVENT ÊTRE JETÉES.

NOTICE DISPONIBLE AU TÉLÉCHARGEMENT SUR :

WWW.RG-RACING.COM

R&G

Unit 1, Shelley's Lane, East Worldham, Alton, Hampshire, GU34 3AQ

Tel: +44 (0)1420 89007 Fax: +44 (0)1420 87301 www.rg-racing.com Email: info@rg-racing.com



<u>OUTILS REQUIS</u>	<u>VALEURS DE SERRAGE</u>
<ul style="list-style-type: none"> • Clés Allen 3, 4, 5 & 6mm • Clé à molette 12mm. • Tournevis cruciforme. • Petit tournevis plat. 	M4 BOULON = 8Nm M5 BOULON = 12Nm M6 BOULON = 15Nm M8 BOULON = 20Nm M10 BOULON = 40Nm M12 BOULON = 40Nm

LÉGENDE

ITEM No.	DESCRIPTION	QTÉ
ITEM 1	TB0325 - SUPPORT DE PLAQUE	1
ITEM 2	M6x35mm BOULON	4
ITEM 3	M6 RONDELLE	4
ITEM 4	IWC0002 CACHE FIL DE MINI CLIGNOTANT	2
ITEM 5	150mm LONGUEUR DE MANCHON THERMO RÉTRACTABLE	2
ITEM 6	2.5mm COLLIER DE SERRAGE 220mm DE LONG	2
ITEM 7	REFL 3 - RÉFLECTEUR	1
ITEM 8	OEILLET D'OBTURATION DE MINI CLIGNOTANT	2
ITEM 9	CON013 CONNECTEUR DE MINI CLIGNOTANT	2

R&G

Unit 1, Shelley's Lane, East Worldham, Alton, Hampshire, GU34 3AQ

Tel: +44 (0)1420 89007 Fax: +44 (0)1420 87301 www.rg-racing.com Email: info@rg-racing.com



SCHÉMA D'ASSEMBLAGE

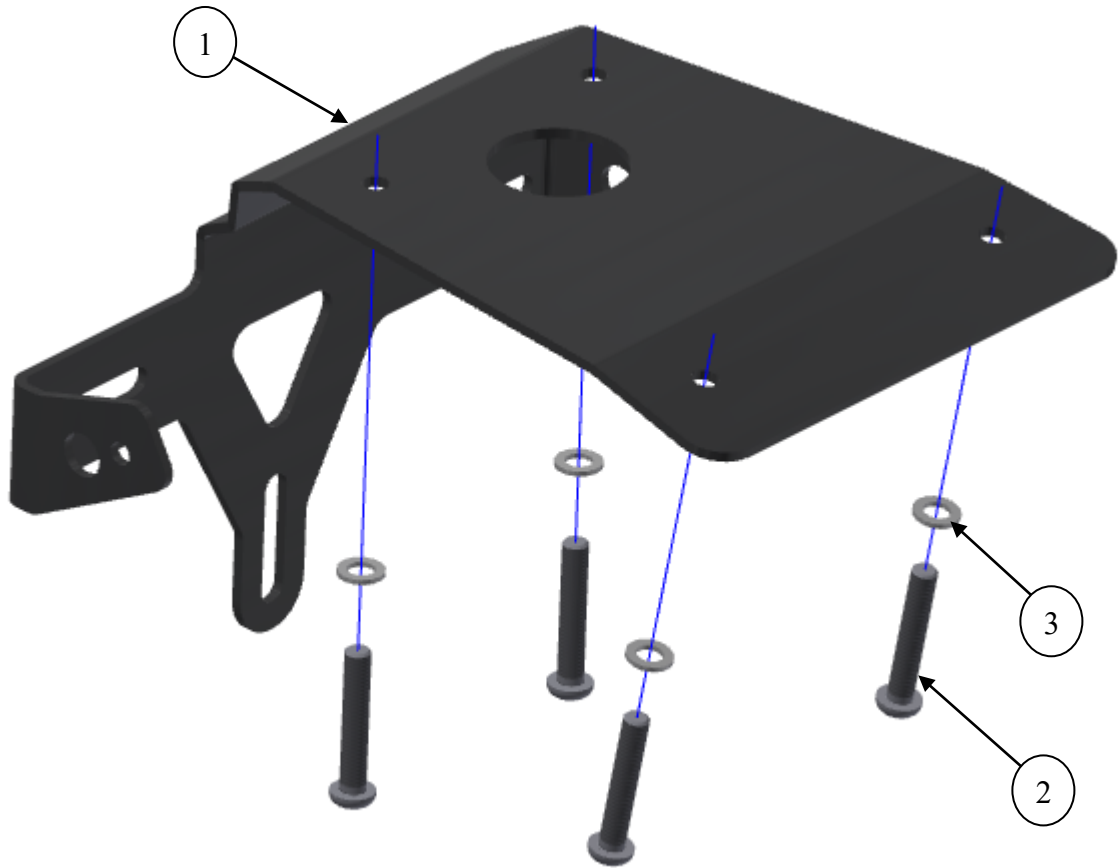

R&G

Unit 1, Shelley's Lane, East Worldham, Alton, Hampshire, GU34 3AQ

Tel: +44 (0)1420 89007 Fax: +44 (0)1420 87301 www.rg-racing.com Email: info@rg-racing.com



PHOTOS DE MONTAGE



Photo 1



Photo 2



Photo 3

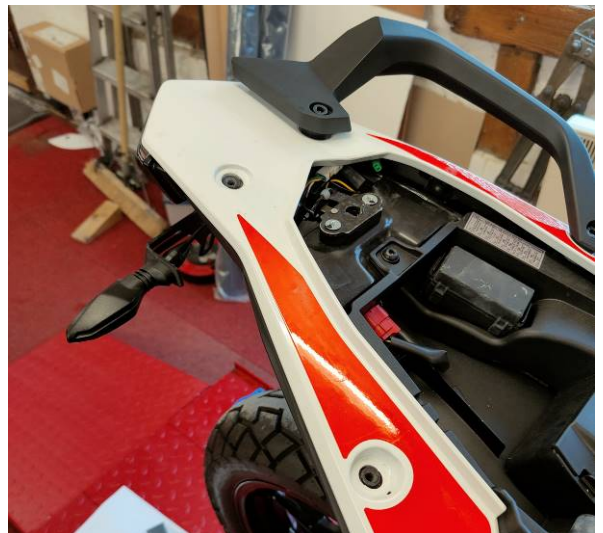

Photo 4

R&G

Unit 1, Shelley's Lane, East Worldham, Alton, Hampshire, GU34 3AQ

Tel: +44 (0)1420 89007 Fax: +44 (0)1420 87301 www.rg-racing.com Email: info@rg-racing.com



Photo 5



Photo 6



Photo 7

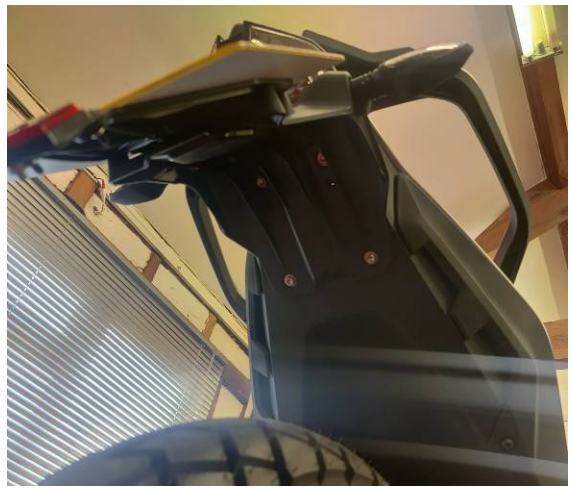

Photo 8

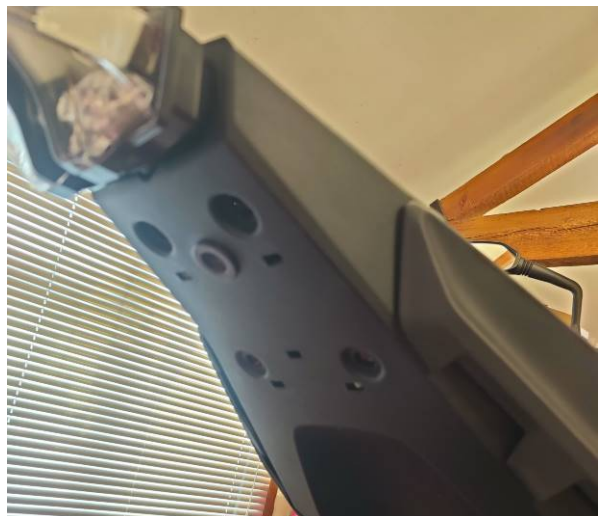

Photo 9



Photo 10

R&G



Photo 11



Photo 12



Photo 13

NOTICE DE MONTAGE

- Utilisez la clé pour retirer le siège comme indiqué sur les photos 1 et 2.
- Retirez les barres d'appui arrière à l'aide d'une clé Allen de 6 mm comme indiqué sur les photos 3 et 4.
- Retirez ensuite le panneau de carénage arrière à l'aide d'une clé Allen de 5 mm en retirant la vis illustrée sur la photo 6 des deux côtés.
- Maintenant que le câblage est exposé, les clignotants peuvent être déconnectés avant que le support de plaque d'immatriculation d'origine ne soit retiré. Notez les fils qui mènent aux clignotants gauche et droit afin qu'ils puissent être reconnectés correctement.
- Retirez les 4 boulons illustrés sur la photo 8 qui fixent le support de plaque d'immatriculation d'origine à la moto.
- Le support de plaque d'immatriculation d'origine peut ensuite être doucement tiré et déclipsé de la moto. Faites passer avec précaution les fils de clignotant à travers le passe-fil en caoutchouc.

R&G

Unit 1, Shelley's Lane, East Worldham, Alton, Hampshire, GU34 3AQ

Tel: +44 (0)1420 89007 Fax: +44 (0)1420 87301 www.rg-racing.com Email: info@rg-racing.com



- Une fois le support de plaque d'immatriculation d'origine retiré de la moto, les clignotants d'origine peuvent être retirés avec une clé de 12 mm. Voir photo 10.
- Si vous réutilisez les clignotants d'origine, ceux-ci peuvent être fixés au support arrière R&G.
- Si vous utilisez les mini clignotants R&G ou d'autres clignotants de rechange, ceux-ci peuvent être attachés à la place, mais le fil de connecteur doit être attaché afin de s'interfacer avec le faisceau de câbles d'origine.
- Les fils doivent ensuite être réinsérés dans le passe-fil en caoutchouc, comme indiqué sur la photo 12.
- Le support R&G peut ensuite être fixé à l'aide des 4 boulons et rondelles M6 fournis, comme indiqué sur la photo 13.
- Les clignotants peuvent ensuite être reconnectés au faisceau de câbles de la moto et tous les câbles exposés peuvent être rangés avec les attaches de câble fournies. Assurez-vous que les clignotants clignotent correctement.
- Remontez le panneau de carénage arrière, les barres d'appui et le siège.

IMPORTANT : SI VOUS INSTALLEZ UNE PLAQUE D'IMMATRICULATION DE GRANDE TAILLE ET LA PLACEZ LOIN VERS LE BAS SUR LE SUPPORT DE PLAQUE D'IMMATRICULATION, IL Y A UNE FAIBLE CHANCE QUE LA PLAQUE D'IMMATRICULATION FRAPPE LA ROUE ARRIÈRE SOUS L'EFFET D'UNE CHARGE LOURDE ET SUR DE GRANDES BOSSES SUR LA ROUTE. IL EST DE VOTRE RESPONSABILITÉ DE VÉRIFIER CETTE POSSIBILITÉ ET DE PRENDRE DES MESURES POUR L'ÉVITER. NE PAS VÉRIFIER CECI POURRAIT ENTRAÎNER DES BLESSURES GRAVES.

ISSUE 1 - 20/09/2021 - (WW)

CONSUMER NOTICE

The catalogue description and any exhibition of samples are only broad indications of the Products and R&G may make design changes which do not diminish their performance or visual appeal and supplying them in such state shall conform to the order. The Buyer acknowledges no representation or warranty (other than as to title) has been given or will apply to the Products other than those in R&G's order or confirmation and the Buyer confirms it has chosen the Products as being of merchantable quality and suitable for its particular purposes. Where R&G fits the Products or undertakes other services it shall exercise reasonable skill and care and rectify any fault free of charge unless the workmanship has been disturbed. The Buyer is responsible for ensuring that the warranty on the motorcycle is not affected by the fitting of the Products. On return of any defective Products R&G shall at its option either supply a replacement or refund the purchase money but shall not be liable if the Products have been modified or used or maintained otherwise than in accordance with R&G's or manufacturer's instructions and good engineering practice or if the defect arises from accident or neglect. Other than identified above and subject to R&G not limiting its liability for causing death and personal injury, it shall not be liable for indirect or consequential loss and otherwise its liability shall be limited to the amounts paid by the Buyer for the Products or the fitting or service concerned. These terms do not affect the Buyer's statutory rights.

R&G RACING RETURNS POLICY (NON-FAULTY GOODS)

Returns must be pre-authorized (if not pre-authorized the return will be rejected). Goods may only be returned direct to us if they were purchased direct from us (customer must prove if necessary). Otherwise to be returned to original vendor. Goods must be in re-sellable condition, in the opinion of R&G Racing. All returns are subject to a 25% restocking and handling fee (25% of the gross value exc. P&P – at the prevailing price at time of purchase). The customer must pay any and all carriage charges. No returns of discontinued products, unless within 14 days of purchase. This policy does not affect your statutory rights and does not refer to faulty goods.

R&G

Unit 1, Shelley's Lane, East Worldham, Alton, Hampshire, GU34 3AQ

Tel: +44 (0)1420 89007 Fax: +44 (0)1420 87301 www.rg-racing.com Email: info@rg-racing.com

