



FITTING INSTRUCTIONS FOR FI0107BK FRAME INSERT
KAWASAKI NINJA H2 2015- LOWER RIGHT HAND SIDE



THIS KIT CONTAINS THE ITEMS PICTURED AND LABELLED BELOW.
DO NOT PROCEED UNTIL YOU ARE SURE ALL PARTS ARE PRESENT.

Please note that the way the kit is packed does not necessarily represent the way of mounting to the bike

THE PARTS SHOWN MAY BE REPRESENTATIVE ONLY (FOR CLARITY OF INSTRUCTIONS ONLY)

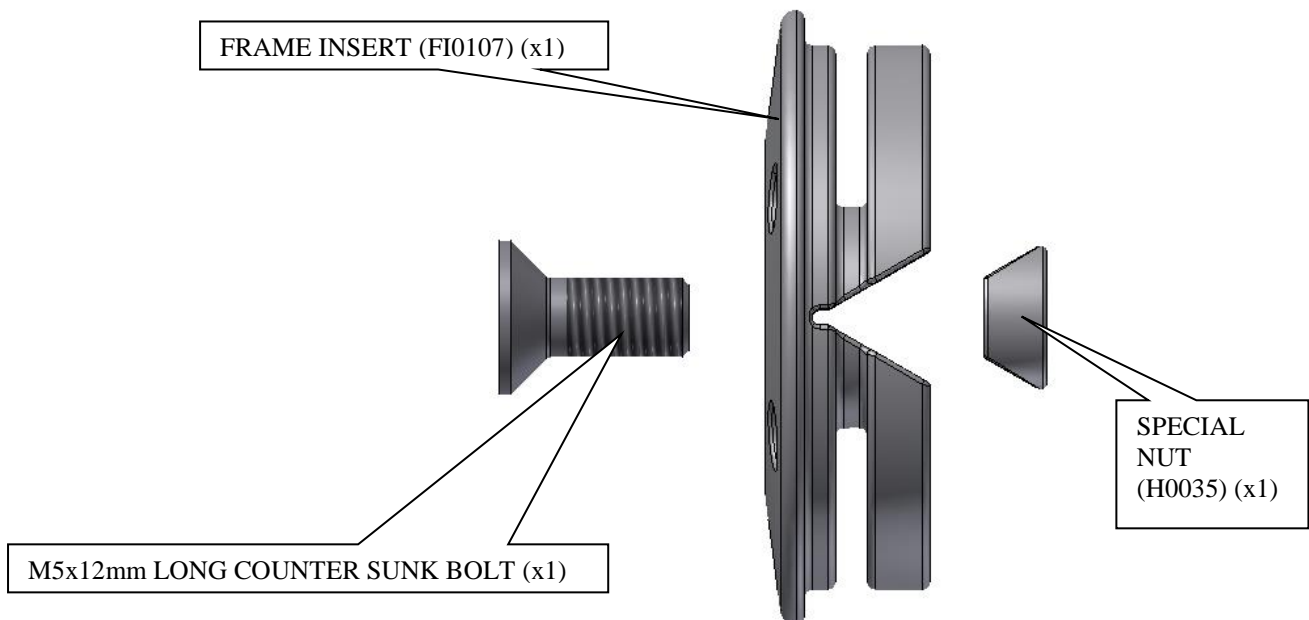

Please note that in cases where kits are packed with rubber washers holding the components onto the bolt – *the rubber washers should be thrown away!*

R&G Racing
Unit 1, Shelleys Lane, East Worldham, Alton, Hampshire, GU34 3AQ

Tel: +44 (0) 1420 89007 | Fax : +44 (0) 1420 87301 | Email: info@rg-racing.com



TOOLS REQUIRED

- 3mm metric Allen key.

Right-hand side (Lower)

- Fit the counter sunk headed bolt through frame insert so head sits in counter-sink.
- Place special nut on exposed end of bolt so tapered face goes into tapered recess.
- Tighten bolt until tapered portion of nut just contacts tapered face of plastic frame insert.
- Place the assembly into the frame recess.
- Tighten bolt so frame insert is held in position firmly (do not over tighten).
- Place bubble sticker as shown above.
- **Regularly check to ensure frame insert remains tight.**

ISSUE 1 NSY 13/05/2015

CONSUMER NOTICE

The catalogue description and any exhibition of samples are only broad indications of the Products and R&G may make design changes which do not diminish their performance or visual appeal and supplying them in such state shall conform to the order. The Buyer acknowledges no representation or warranty (other than as to title) has been given or will apply to the Products other than those in R&G's order or confirmation and the Buyer confirms it has chosen the Products as being of merchantable quality and suitable for its particular purposes. Where R&G fits the Products or undertakes other services it shall exercise reasonable skill and care and rectify any fault free of charge unless the workmanship has been disturbed. The Buyer is responsible for ensuring that the warranty on the motorcycle is not affected by the fitting of the Products. On return of any defective Products R&G shall at its option either supply a replacement or refund the purchase money but shall not be liable if the Products have been modified or used or maintained otherwise than in accordance with R&G's or manufacturer's instructions and good engineering practice or if the defect arises from accident or neglect. Other than identified above and subject to R&G not limiting its liability for causing death and personal injury, it shall not be liable for indirect or consequential loss and otherwise its liability shall be limited to the amounts paid by the Buyer for the Products or the fitting or service concerned. These terms do not affect the Buyer's statutory rights.

R&G RACING RETURNS POLICY (NON-FAULTY GOODS)

Returns must be pre-authorized (if not pre-authorized the return will be rejected). Goods may only be returned direct to us if they were purchased direct from us (customer must prove if necessary). Otherwise to be returned to original vendor. Goods must be in re-sellable condition, in the opinion of R&G Racing. All returns are subject to a 25% restocking and handling fee (25% of the gross value exc. P&P – at the prevailing price at time of purchase). The customer must pay any and all carriage charges. No returns of discontinued products, unless within 14 days of purchase. This policy does not affect your statutory rights and does not refer to faulty goods.

R&G Racing

Unit 1, Shelleys Lane, East Worldham, Alton, Hampshire, GU34 3AQ

Tel: +44 (0) 1420 89007 | Fax : +44 (0) 1420 87301 | Email: info@rg-racing.com



INSTRUCTIONS DE MONTAGE FI0107BK INSERT CADRE
KAWASAKI NINJA H2 2015- COTE GAUCHE & DROIT INFERIEUR



LE KIT CONTIENT LES ARTICLES EXPOSES CI-DESSOUS, VERIFIER QUE TOUTES LES PIECES SOIENT PRESENTES AVANT DE PROCEDER AU MONTAGE.

LA FAÇON DONT LE KIT EST EMBALLE NE CORRESPOND PAS FORCEMENT A LA FAÇON DE MONTER LES PIECES SUR LA MOTO.

LES PARTIES PRESENTEES PEUVENT ETRE UNIQUEMENT REPRESENTATIVES (POUR LA CLARTE DES INSTRUCTIONS UNIQUEMENT).

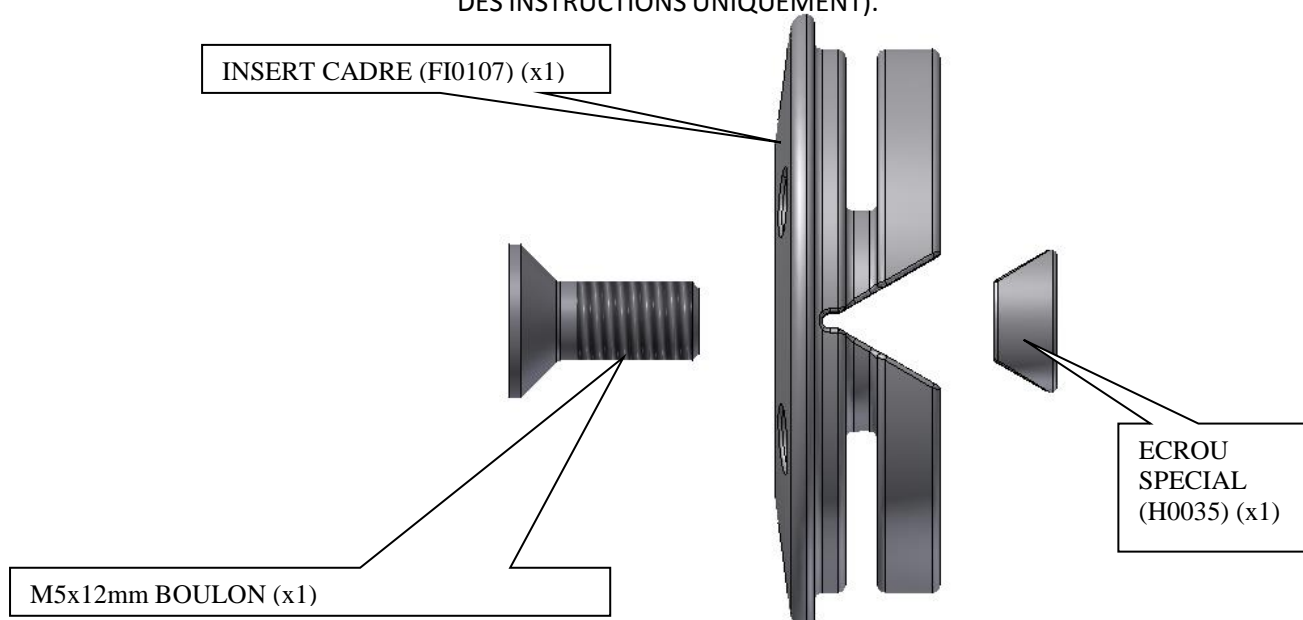

Notez que si les kits sont emballés avec des rondelles en caoutchouc servant à tenir les composants, *ces rondelles doivent être jetées.*

R&G Racing
Unit 1, Shelleys Lane, East Worldham, Alton, Hampshire, GU34 3AQ

Tel: +44 (0) 1420 89007 | Fax : +44 (0) 1420 87301 | Email: info@rg-racing.com



Outils requis

- Clé Allen 3mm.

Coté droit inférieur (Inférieur)

- Passer le boulon à travers l'insert de cadre de façon à ce que la tête se place dans le contre alésage.
- Placer l'écrou spécial sur l'extrémité exposée du boulon pour que la face conique aille dans le creux conique.
- Serrer le boulon jusqu'à ce que la portion conique de l'écrou vienne toucher la partie conique de l'insert cadre en plastique.
- Placer l'ensemble dans le creux du cadre.
- Serrer le boulon pour que l'insert de cadre soit tenu correctement en position (Ne pas bloquer).
- Placer le sticker caoutchouc comme ci dessus.
- **Vérifier régulièrement le serrage de l'insert de cadre.**

ISSUE 1 NSY 13/05/2015

CONSUMER NOTICE

The catalogue description and any exhibition of samples are only broad indications of the Products and R&G may make design changes which do not diminish their performance or visual appeal and supplying them in such state shall conform to the order. The Buyer acknowledges no representation or warranty (other than as to title) has been given or will apply to the Products other than those in R&G's order or confirmation and the Buyer confirms it has chosen the Products as being of merchantable quality and suitable for its particular purposes. Where R&G fits the Products or undertakes other services it shall exercise reasonable skill and care and rectify any fault free of charge unless the workmanship has been disturbed. The Buyer is responsible for ensuring that the warranty on the motorcycle is not affected by the fitting of the Products. On return of any defective Products R&G shall at its option either supply a replacement or refund the purchase money but shall not be liable if the Products have been modified or used or maintained otherwise than in accordance with R&G's or manufacturer's instructions and good engineering practice or if the defect arises from accident or neglect. Other than identified above and subject to R&G not limiting its liability for causing death and personal injury, it shall not be liable for indirect or consequential loss and otherwise its liability shall be limited to the amounts paid by the Buyer for the Products or the fitting or service concerned. These terms do not affect the Buyer's statutory rights.

R&G RACING RETURNS POLICY (NON-FAULTY GOODS)

Returns must be pre-authorized (if not pre-authorized the return will be rejected). Goods may only be returned direct to us if they were purchased direct from us (customer must prove if necessary). Otherwise to be returned to original vendor. Goods must be in re-sellable condition, in the opinion of R&G Racing. All returns are subject to a 25% restocking and handling fee (25% of the gross value exc. P&P – at the prevailing price at time of purchase). The customer must pay any and all carriage charges. No returns of discontinued products, unless within 14 days of purchase. This policy does not affect your statutory rights and does not refer to faulty goods.

R&G Racing

Unit 1, Shelleys Lane, East Worldham, Alton, Hampshire, GU34 3AQ

Tel: +44 (0) 1420 89007 | Fax : +44 (0) 1420 87301 | Email: info@rg-racing.com