

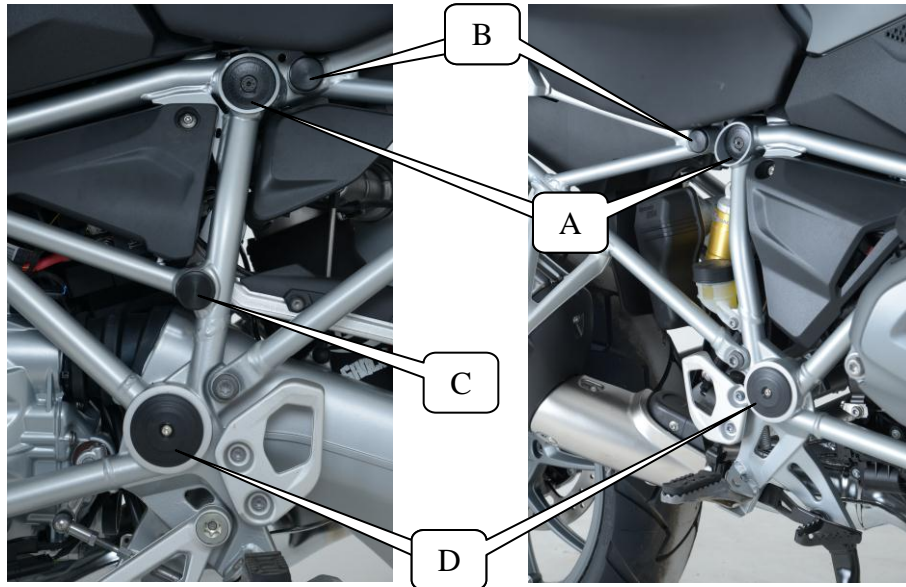

FITTING INSTRUCTIONS FOR FI0069BK FRAME INSERT
BMW R1200GS 2013- FRAME INSERT KIT



THIS KIT CONTAINS THE ITEMS PICTURED AND LABELLED BELOW.
DO NOT PROCEED UNTIL YOU ARE SURE ALL PARTS ARE PRESENT.

Please note that the way the kit is packed does not necessarily represent the way of mounting to the bike

THE PARTS SHOWN MAY BE REPRESENTATIVE ONLY (FOR CLARITY OF INSTRUCTIONS ONLY)

Please note that in cases where kits are packed with rubber washers holding the components onto the bolt – *the rubber washers should be thrown away!*

TOOLS REQUIRED

- 3 & 4mm Metric Allen key.
- Soft Mallet.

FITTING INSTRUCTIONS

FI0069 – pictured as A

- Fit one of the M6 x 20mm long countersunk bolts into each of the thicker frame inserts (FI0069) so head sits in counter-bore. *These bolts have no function and are purely for aesthetics.*

R&G Racing
Unit 1, Shelleys Lane, East Worldham, Alton, Hampshire, GU34 3AQ

Tel: +44 (0) 1420 89007 | Fax : +44 (0) 1420 87301 | Email: info@rg-racing.com



- Offer these up to the bike in the recess for the shock mounting bolt as shown above, then gently push into place. The angled end makes fitting tricky and a gentle tap with a soft mallet will help to locate. Ensure the frame insert sits below the edge of the frame boss.
- *To remove the frame inserts, simply remove the countersunk bolt and replace with a long old M6 bolt. Insert the thread by at least 15mm and pull out using a set of pliers on the end of the bolt.*

FI0070 – pictured as B

- Take one of the plastic bung type frame inserts (with the smaller diameter head) and gently push into the subframe mounting frame boss as shown above.
- If tight, a gentle tap with a soft mallet will help to locate the frame insert.
- Repeat this process to fit the frame insert to the opposite side of the bike.
- *To remove the frame inserts, use a thin screwdriver or steel rule to get under the edge to pull out.*

FI0071 – pictured as C

- Take one of the plastic bung type frame inserts (with the larger diameter head) and gently push into the swingarm linkage mounting boss as shown above.
- If tight, a gentle tap with a soft mallet will help to locate the frame insert.
- Repeat this process to fit the frame insert to the opposite side of the bike.
- *To remove the frame inserts, use a thin screwdriver or steel rule to get under the edge to pull out.*

FI0072 – pictured as D

- Take one of the larger expanding frame inserts, and locate one of the M5 x 20mm long button head bolts through the frame insert and fit one of the tapered stainless nuts onto the end of the exposed thread.
- Tighten the bolt in the expanding frame insert until the tapered nut starts to grip the inside of the expander.
- Position the frame insert into the hexagonal recess on the swingarm pivot nut/bolt in position as shown above and hold in place whilst tightening the bolt, ensuring the oval shaped recess is horizontal. The back of the frame insert will expand and hold the frame insert securely in place.
- Fit one of the bubble stickers into the recess on the frame insert.
- Repeat this process to fit the frame insert to the opposite side of the bike.

- *Regularly check to ensure frame inserts remains tight.*

Issue 1 15/05/2013 AR

R&G Racing
Unit 1, Shelleys Lane, East Worldham, Alton, Hampshire, GU34 3AQ

Tel: +44 (0) 1420 89007 | Fax : +44 (0) 1420 87301 | Email: info@rg-racing.com



CONSUMER NOTICE

The catalogue description and any exhibition of samples are only broad indications of the Products and R&G may make design changes which do not diminish their performance or visual appeal and supplying them in such state shall conform to the order. The Buyer acknowledges no representation or warranty (other than as to title) has been given or will apply to the Products other than those in R&G's order or confirmation and the Buyer confirms it has chosen the Products as being of merchantable quality and suitable for its particular purposes. Where R&G fits the Products or undertakes other services it shall exercise reasonable skill and care and rectify any fault free of charge unless the workmanship has been disturbed. The Buyer is responsible for ensuring that the warranty on the motorcycle is not affected by the fitting of the Products. On return of any defective Products R&G shall at its option either supply a replacement or refund the purchase money but shall not be liable if the Products have been modified or used or maintained otherwise than in accordance with R&G's or manufacturer's instructions and good engineering practice or if the defect arises from accident or neglect. Other than identified above and subject to R&G not limiting its liability for causing death and personal injury, it shall not be liable for indirect or consequential loss and otherwise its liability shall be limited to the amounts paid by the Buyer for the Products or the fitting or service concerned. These terms do not affect the Buyer's statutory rights.

R&G RACING RETURNS POLICY (NON-FAULTY GOODS)

Returns must be pre-authorized (if not pre-authorized the return will be rejected). Goods may only be returned direct to us if they were purchased direct from us (customer must prove if necessary). Otherwise to be returned to original vendor. Goods must be in resellable condition, in the opinion of R&G Racing. All returns are subject to a 25% restocking and handling fee (25% of the gross value exc. P&P – at the prevailing price at time of purchase). The customer must pay any and all carriage charges. No returns of discontinued products, unless within 14 days of purchase. This policy does not affect your statutory rights and does not refer to faulty goods.

R&G Racing
Unit 1, Shelleys Lane, East Worldham, Alton, Hampshire, GU34 3AQ

Tel: +44 (0) 1420 89007 | Fax : +44 (0) 1420 87301 | Email: info@rg-racing.com



Instructions de montage pour FI0069BK Insert de cadre
BMW R1200GS 2013- Kit Insert de cadre

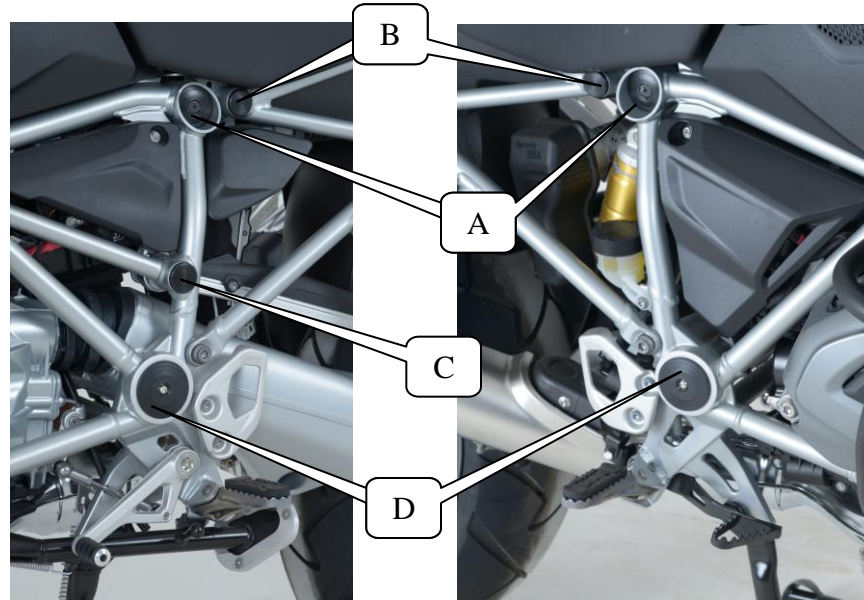

Le kit contient les articles exposés ci-dessous, vérifier que toutes les pièces soient présentes avant de procéder au montage.

La façon dont le kit est emballé ne correspond pas forcément à la façon de monter les pièces sur la moto.

Les pièces présentées peuvent n'être que représentatives, afin de faciliter et clarifier les instructions de montage.

Notez que si les kits sont emballés avec des rondelles en caoutchouc servant à tenir les composants, *ces rondelles doivent être jetées.*

Outils requis

- Clé Allen 3 & 4mm.
- Petit maillet

Instructions de montage:

FI0069 – photographié A

- Visser un des boulons M6 x 20mm sur chacun des inserts de cadre épais (FI0069) de façon à ce que la tête se place dans le contre alésage. Ces boulons n'ont pas de fonction et sont placés ici uniquement pour l'esthétisme.

R&G Racing
Unit 1, Shelleys Lane, East Worldham, Alton, Hampshire, GU34 3AQ

Tel: +44 (0) 1420 89007 | Fax : +44 (0) 1420 87301 | Email: info@rg-racing.com



- Posez-les sur la moto, dans le creux pour le boulon de support de choc comme indiqué ci dessus, puis mettez-les en place. L'extrémité coudée fait raccord et un petit coup de maillet vous aidera à effectuer le placement. Assurez-vous que l'insert de cadre se place en dessous du bord du patron dans le cadre.
- *Pour enlever les inserts, enlever simplement le boulon puis remplacez-le par un long boulon M6. Insérer le filetage par au moins 15mm puis tirer à l'aide d'un jeu de pinces sur l'extrémité du boulon.*

FI0070 – photographié B

- Prendre un des bouchons de plastique d'insert de cadre (avec la tête au diamètre plus petit), puis insérez le dans le trou de support de sous cadre comme indiqué ci dessus).
- Si serré, un léger coup de maillet aidera à placer l'insert de cadre.
- Répéter ce process pour insérer l'insert de cadre de l'autre coté de la moto.
- *Pour enlever les inserts de cadre, utiliser un tournevis cruciforme fin ou une règle en fer en la placant en dessous du bord de l'insert, avant de tirer pour l'extraire.*

FI0071 – photographié C

- Prendre un des bouchons de plastique d'insert de cadre (avec la tête au diamètre plus large), et poussez-le doucement dans le raccord de liaison du bras oscillant, comme indiqué ci-dessus.
- Si serré, un léger coup de maillet aidera à placer l'insert de cadre.
- Répéter ce process pour insérer l'insert de cadre de l'autre coté de la moto.
- *Pour enlever les inserts de cadre, utiliser un tournevis cruciforme fin ou une règle en fer en la placant en dessous du bord de l'insert, avant de tirer pour l'extraire.*

FI0072 – photographié D

- Prendre un des gros inserts élargis, et insérer un des boulons M5 x 20mm à travers l'insert de cadre puis insérer un des écrous coniques en acier inoxydable sur l'extrémité du filetage exposé.
- Serrer le boulon dans l'insert de cadre élargi jusqu'à ce que l'écrou conique commence à serrer l'intérieur de l'élargisseur.
- Positionner l'insert de cadre dans le creux hexagonal sur l'écrou de pivot de bras oscillant/Boulon en position indiquée ci dessus puis tenez le en place tout en serrant le boulon, en vous assurant que l'évidement de forme ovale soit à l'horizontal. L'arrière de l'insert de cadre élargira et tiendra l'insert correctement en place, de façon sécurisée.
- Poser un des stickers en caoutchouc dans le creux de l'insert de cadre.
- Répéter ce processus pour installer l'autre insert de cadre de l'autre coté de la moto.
- *Vérifier régulièrement le serrage de l'insert*

Issue 1 15/05/2013 AR

R&G Racing
Unit 1, Shelleys Lane, East Worldham, Alton, Hampshire, GU34 3AQ

Tel: +44 (0) 1420 89007 | Fax : +44 (0) 1420 87301 | Email: info@rg-racing.com



CONSUMER NOTICE

The catalogue description and any exhibition of samples are only broad indications of the Products and R&G may make design changes which do not diminish their performance or visual appeal and supplying them in such state shall conform to the order. The Buyer acknowledges no representation or warranty (other than as to title) has been given or will apply to the Products other than those in R&G's order or confirmation and the Buyer confirms it has chosen the Products as being of merchantable quality and suitable for its particular purposes. Where R&G fits the Products or undertakes other services it shall exercise reasonable skill and care and rectify any fault free of charge unless the workmanship has been disturbed. The Buyer is responsible for ensuring that the warranty on the motorcycle is not affected by the fitting of the Products. On return of any defective Products R&G shall at its option either supply a replacement or refund the purchase money but shall not be liable if the Products have been modified or used or maintained otherwise than in accordance with R&G's or manufacturer's instructions and good engineering practice or if the defect arises from accident or neglect. Other than identified above and subject to R&G not limiting its liability for causing death and personal injury, it shall not be liable for indirect or consequential loss and otherwise its liability shall be limited to the amounts paid by the Buyer for the Products or the fitting or service concerned. These terms do not affect the Buyer's statutory rights.

R&G RACING RETURNS POLICY (NON-FAULTY GOODS)

Returns must be pre-authorized (if not pre-authorized the return will be rejected). Goods may only be returned direct to us if they were purchased direct from us (customer must prove if necessary). Otherwise to be returned to original vendor. Goods must be in resellable condition, in the opinion of R&G Racing. All returns are subject to a 25% restocking and handling fee (25% of the gross value exc. P&P – at the prevailing price at time of purchase). The customer must pay any and all carriage charges. No returns of discontinued products, unless within 14 days of purchase. This policy does not affect your statutory rights and does not refer to faulty goods.

R&G Racing
Unit 1, Shelleys Lane, East Worldham, Alton, Hampshire, GU34 3AQ

Tel: +44 (0) 1420 89007 | Fax : +44 (0) 1420 87301 | Email: info@rg-racing.com