



**FITTING INSTRUCTIONS FOR CLG0032CG/LH FACTORY CARBON LEVER DEFENDER
HOLLOW TUBE BARS 13-15MM MOST HONDA**



THIS KIT CONTAINS THE ITEMS PICTURED AND LABELLED OVER PAGE.

SOME PARTS MAY BE SHOWN FOR CLARITY OF INSTRUCTIONS ONLY.

DO NOT PROCEED UNTIL YOU ARE SURE ALL PARTS ARE PRESENT.

PLEASE READ ALL INSTRUCTIONS BEFORE PROCEEDING.

**IF IN ANY DOUBT WHEN FITTING OUR PRODUCTS, CONSULT ONE OF OUR DEALERS
OR HAVE FITTED BY A QUALIFIED TECHNICIAN.**

PLEASE NOTE THAT THE WAY THE KIT IS PACKED DOES NOT NECESSARILY REPRESENT THE WAY OF
MOUNTING TO THE BIKE.

IN THE EVENT OF RUBBER WASHERS BEING USED TO HOLD COMPONENTS ONTO BOLTS,
THESE RUBBER WASHERS CAN BE THROWN AWAY.

DIGITAL COPIES OF THESE INSTRUCTIONS ARE AVAILABLE FROM:

WWW.RG-RACING.COM



<u>TOOLS REQUIRED</u>	<u>GENERAL TORQUE SETTINGS</u>
<ul style="list-style-type: none"> • ALLEN TOOL SET TO INCLUDE 4mm A/F SIZE. • SPECIFIC TOOLS REQUIRED TO REMOVE OEM BAR-ENDS, IF APPLICABLE. 	<p>M4 BOLT = 8Nm</p> <p>M5 BOLT = 12Nm</p> <p>M6 BOLT = 15Nm</p> <p>M8 BOLT = 20Nm</p> <p>M10 BOLT = 40Nm</p> <p>M12 BOLT = 40Nm</p>

LEGEND

ITEM NO.	DESCRIPTION	QTY
ITEM 1	CARBON LEVER GUARD (LG0006COMP).	1
ITEM 2	H0055 TAPERED NUT (13-15mm)	1
ITEM 3	S1324 13-15mm EXPANDER	1
ITEM 4	S0840 CONE SPACER FOR EXPANDER (13-15mm)	1
ITEM 5	S0781 CONE SPACER	1
ITEM 6	S0928 CLAMP SPACER	1
ITEM 7	M6 x 1.00 x 90.00mm COUNTER-SUNK BOLT	1

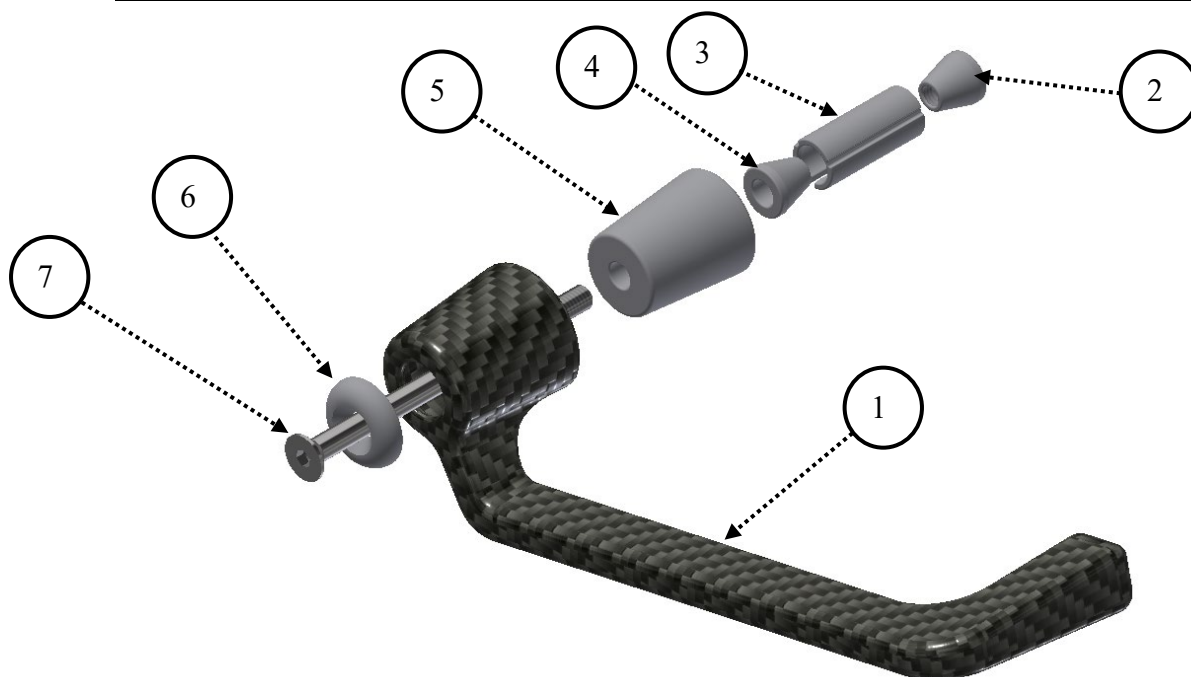

EXPLODED ASSEMBLY VIEW



FITTING INSTRUCTIONS

- To fit the R&G Brake Lever Guard, you will need to remove the original bar-end using the specific tools to your bike.
- Place the counter-sunk bolt (**item 7**) through the clamp spacer (**item 6**), then place the bolt and clamp spacer through the brake lever guard (**item 1**).
- Place the large cone spacer (**item 5**) over the exposed thread (so it sits into the lever guard).
- Place the smallest (unthreaded) cone spacer (**item 4**) over the exposed thread (so it sits against the large cone spacer).
- Place the expander (**item 3**) over the exposed thread (so it sits against the tapered spacer just fitted).
- Place the tapered nut (**item 2**) onto the thread and engage until it locates in the expander just fitted.
- Locate the assembly into the bar and position so when the motorcycle is at full lock in both directions it does not contact any other part of the motorcycle or **restrict throttle use**.
- Using a 4mm Allen tool, fully tighten the bolt and check operation.

IMPORTANT - WHEN FITTING THIS PRODUCT, IT IS YOUR RESPONSIBILITY TO ENSURE THAT THE PRODUCT IN NO WAY IMPEDES THE OPERATION OF THE MOTORCYCLE AND IS CHECKED REGULARLY FOR TIGHTNESS AND CORRECT OPERATION.

FAILURE TO CHECK THE ABOVE COULD RESULT IN SERIOUS INJURY OR DAMAGE.

ISSUE 1 – 10/01/2022

CONSUMER NOTICE

The catalogue description and any exhibition of samples are only broad indications of the Products and R&G may make design changes which do not diminish their performance or visual appeal and supplying them in such state shall conform to the order. The Buyer acknowledges no representation or warranty (other than as to title) has been given or will apply to the Products other than those in R&G's order or confirmation and the Buyer confirms it has chosen the Products as being of merchantable quality and suitable for its particular purposes. Where R&G fits the Products or undertakes other services it shall exercise reasonable skill and care and rectify any fault free of charge unless the workmanship has been disturbed. The Buyer is responsible for ensuring that the warranty on the motorcycle is not affected by the fitting of the Products. On return of any defective Products R&G shall at its option either supply a replacement or refund the purchase money but shall not be liable if the Products have been modified or used or maintained otherwise than in accordance with R&G's or manufacturer's instructions and good engineering practice or if the defect arises from accident or neglect. Other than identified above and subject to R&G not limiting its liability for causing death and personal injury, it shall not be liable for indirect or consequential loss and otherwise its liability shall be limited to the amounts paid by the Buyer for the Products or the fitting or service concerned. These terms do not affect the Buyer's statutory rights.

R&G RACING RETURNS POLICY (NON-FAULTY GOODS)

Returns must be pre-authorized (if not pre-authorized the return will be rejected). Goods may only be returned direct to us if they were purchased direct from us (customer must prove if necessary). Otherwise to be returned to original vendor. Goods must be in re-sellable condition, in the opinion of R&G Racing. All returns are subject to a 25% restocking and handling fee (25% of the gross value exc. P&P – at the prevailing price at time of purchase). The customer must pay any and all carriage charges. No returns of discontinued products, unless within 14 days of purchase. This policy does not affect your statutory rights and does not refer to faulty goods.

R&G Racing

Unit 1, Shelley's Lane, East Worldham, Alton, Hampshire, GU34 3AQ

Tel: +44 (0)1420 89007 Fax: +44 (0)1420 87301 www.rg-racing.com Email: info@rg-racing.com



INSTRUCTIONS DE MONTAGE POUR CLG0032CG/LH DEFENDER À LEVIER DE CARBONE
D'USINE
HOLLOW TUBE BARS 13-15MM MOST HONDA



CE KIT CONTIENT LES ARTICLES ILLUSTRÉS ET ÉTIQUETES SUR LA PAGE.

CERTAINES PARTIES PEUVENT ÊTRE PRÉSENTES UNIQUEMENT POUR LA CLARTÉ DES INSTRUCTIONS.

NE PAS PROCÉDER AU MONTAGE TANT QUE VOUS N'ÊTES PAS SÛR QUE TOUTES LES PIÈCES SOIENT PRÉSENTES.

VEUILLEZ LIRE TOUTES LES INSTRUCTIONS AVANT DE CONTINUER.

EN CAS DE DOUTE LORS DU MONTAGE DE NOS PRODUITS, CONSULTEZ UN DE NOS REVENDEURS OU FAITES APPEL A UN TECHNICIEN QUALIFIÉ.

VEUILLEZ NOTER QUE LA FAÇON DONT LE KIT EST EMBALLÉ NE REPRÉSENTE PAS NECESSAIREMENT LA MANIÈRE DE LE MONTER SUR LA MOTO.

SI DES RONDELLES EN CAOUTCHOUC SONT UTILISÉES POUR MAINTENIR LES COMPOSANTS SUR LES BOULONS, ELLES PEUVENT ÊTRE JETÉES.

NOTICE DISPONIBLE AU TÉLÉCHARGEMENT SUR :

WWW.RG-RACING.COM



<u>OUTILS REQUIS</u>	<u>VALEURS DE SERRAGE</u>
<ul style="list-style-type: none"> CLÉ ALLEN 4mm. OUTILS SPÉCIFIQUES POUR ENLEVER LES EXTRÉMITÉS DE GUIDON D'ORIGINE SI POSSIBLE. 	M4 BOULON = 8Nm M5 BOULON = 12Nm M6 BOULON = 15Nm M8 BOULON = 20Nm M10 BOULON = 40Nm M12 BOULON = 40Nm

LÉGENDE

ARTICLE NO.	DESCRIPTION	QTÉ
ARTICLE 1	PROTECTION POIGNEE EN FIBRE DE CARBONE (LG0006COMP).	1
ARTICLE 2	H0055 ÉCROU (13-15mm)	1
ARTICLE 3	S1324 13-15mm EXPANSEUR	1
ARTICLE 4	S0840 ENTRETOISE POUR EXPANSEUR (13-15mm)	1
ARTICLE 5	S0781 ENTRETOISE	1
ARTICLE 6	S0928 ENTRETOISE	1
ARTICLE 7	M6 x 1.00 x 90.00mm BOULON	1

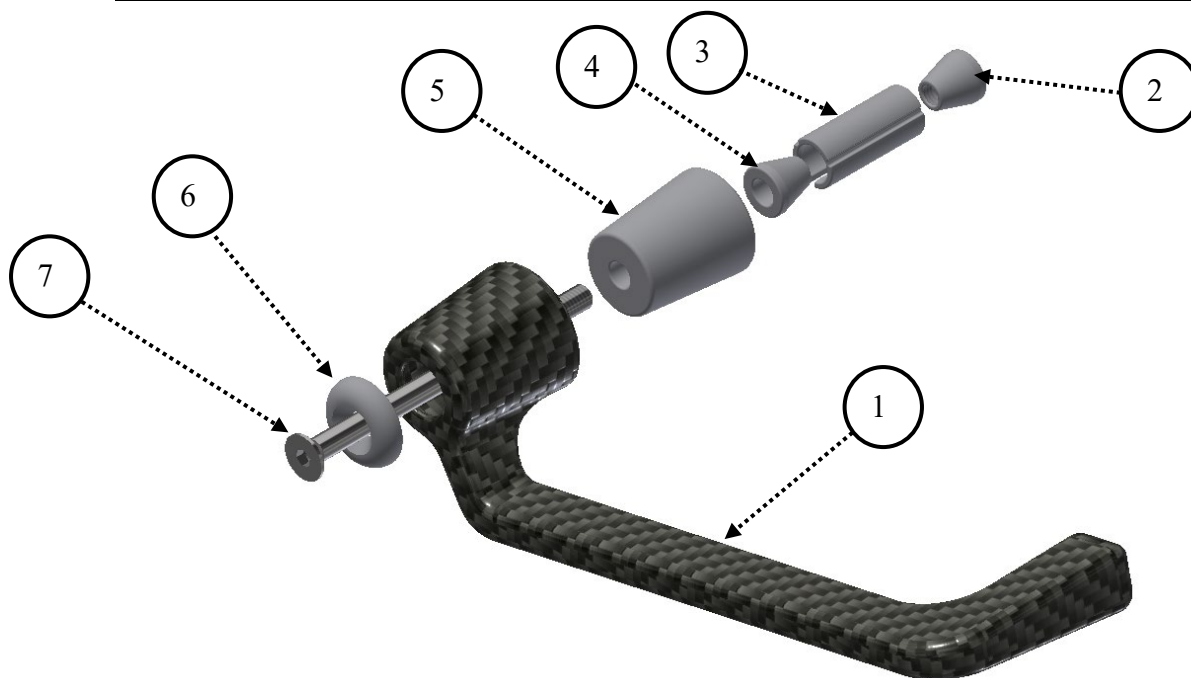

R&G Racing

Unit 1, Shelley's Lane, East Worldham, Alton, Hampshire, GU34 3AQ

Tel: +44 (0)1420 89007 Fax: +44 (0)1420 87301 www.rg-racing.com Email: info@rg-racing.com



VUE D'ENSEMBLE **NOTICE DE MONTAGE**

- Pour monter le protège-levier de frein R&G, vous devrez retirer l'embout de guidon d'origine à l'aide des outils spécifiques à votre moto.
- Placer le boulon à tête fraisée (article 7) à travers l'entretoise de serrage (article 6), puis placer le boulon et l'entretoise de serrage à travers la protection du levier de frein (article 1).
- Placez la grande entretoise conique (article 5) sur le filetage exposé (afin qu'elle s'insère dans le protège-levier).
- Placez la plus petite entretoise conique (non filetée) (article 4) sur le filetage exposé (afin qu'elle repose contre le protège-levier).
- Placer l'expandeur (article 3) sur le filetage exposé (afin qu'il repose contre l'entretoise conique qui vient d'être installée).
- Placer l'écrou conique (article 2) sur le filetage et l'engager jusqu'à ce qu'il se loge dans l'expandeur qui vient d'être mis en place.
- Placez l'ensemble dans le guidon et positionnez-le de sorte que lorsque la moto est complètement verrouillée dans les deux sens, il n'entre en contact avec aucune autre partie de la moto ou ne limite pas l'utilisation de l'accélérateur.
- À l'aide d'une clé Allen de 4 mm, serrez complètement le boulon et vérifiez le fonctionnement.

IMPORTANT - LORS DE L'INSTALLATION DE CE PRODUIT, IL EST DE VOTRE RESPONSABILITÉ DE VOUS ASSURER QUE LE PRODUIT NE PUISSE EN AUCUN CAS ALTÉRER LE FONCTIONNEMENT DE LA MOTO ET DE VÉRIFIER RÉGULIÈREMENT LE SERRAGE ET LE BON FONCTIONNEMENT.

NE PAS VÉRIFIER LES ÉLÉMENTS CI-DESSUS POURRAIT ENTRAÎNER DES BLESSURES OU DES DOMMAGES GRAVES.

ISSUE 1 – 10/01/2022

CONSUMER NOTICE

The catalogue description and any exhibition of samples are only broad indications of the Products and R&G may make design changes which do not diminish their performance or visual appeal and supplying them in such state shall conform to the order. The Buyer acknowledges no representation or warranty (other than as to title) has been given or will apply to the Products other than those in R&G's order or confirmation and the Buyer confirms it has chosen the Products as being of merchantable quality and suitable for its particular purposes. Where R&G fits the Products or undertakes other services it shall exercise reasonable skill and care and rectify any fault free of charge unless the workmanship has been disturbed. The Buyer is responsible for ensuring that the warranty on the motorcycle is not affected by the fitting of the Products. On return of any defective Products R&G shall at its option either supply a replacement or refund the purchase money but shall not be liable if the Products have been modified or used or maintained otherwise than in accordance with R&G's or manufacturer's instructions and good engineering practice or if the defect arises from accident or neglect. Other than identified above and subject to R&G not limiting its liability for causing death and personal injury, it shall not be liable for indirect or consequential loss and otherwise its liability shall be limited to the amounts paid by the Buyer for the Products or the fitting or service concerned. These terms do not affect the Buyer's statutory rights.

R&G RACING RETURNS POLICY (NON-FAULTY GOODS)

Returns must be pre-authorized (if not pre-authorized the return will be rejected). Goods may only be returned direct to us if they were purchased direct from us (customer must prove if necessary). Otherwise to be returned to original vendor. Goods must be in re-sellable condition, in the opinion of R&G Racing. All returns are subject to a 25% restocking and handling fee (25% of the gross value exc. P&P – at the prevailing price at time of purchase). The customer must pay any and all carriage charges.

R&G Racing

Unit 1, Shelley's Lane, East Worldham, Alton, Hampshire, GU34 3AQ

Tel: +44 (0)1420 89007 Fax: +44 (0)1420 87301 www.rg-racing.com Email: info@rg-racing.com



No returns of discontinued products, unless within 14 days of purchase. This policy does not affect your statutory rights and does not refer to faulty goods.



**FITTING INSTRUCTIONS FOR CLG0032CG/RH FACTORY CARBON LEVER DEFENDER
HOLLOW TUBE BARS 13-15MM MOST HONDA**



THIS KIT CONTAINS THE ITEMS PICTURED AND LABELLED OVER PAGE.

SOME PARTS MAY BE SHOWN FOR CLARITY OF INSTRUCTIONS ONLY.

DO NOT PROCEED UNTIL YOU ARE SURE ALL PARTS ARE PRESENT.

PLEASE READ ALL INSTRUCTIONS BEFORE PROCEEDING.

**IF IN ANY DOUBT WHEN FITTING OUR PRODUCTS, CONSULT ONE OF OUR DEALERS
OR HAVE FITTED BY A QUALIFIED TECHNICIAN.**

PLEASE NOTE THAT THE WAY THE KIT IS PACKED DOES NOT NECESSARILY REPRESENT THE WAY OF
MOUNTING TO THE BIKE.

IN THE EVENT OF RUBBER WASHERS BEING USED TO HOLD COMPONENTS ONTO BOLTS,
THESE RUBBER WASHERS CAN BE THROWN AWAY.

DIGITAL COPIES OF THESE INSTRUCTIONS ARE AVAILABLE FROM:

WWW.RG-RACING.COM



<u>TOOLS REQUIRED</u>	<u>GENERAL TORQUE SETTINGS</u>
<ul style="list-style-type: none"> • ALLEN TOOL SET TO INCLUDE 4mm A/F SIZE. • SPECIFIC TOOLS REQUIRED TO REMOVE OEM BAR-ENDS, IF APPLICABLE. 	<p>M4 BOLT = 8Nm</p> <p>M5 BOLT = 12Nm</p> <p>M6 BOLT = 15Nm</p> <p>M8 BOLT = 20Nm</p> <p>M10 BOLT = 40Nm</p> <p>M12 BOLT = 40Nm</p>

LEGEND

ITEM NO.	DESCRIPTION	QTY
ITEM 1	CARBON LEVER GUARD (LG0005COMP).	1
ITEM 2	H0055 TAPERED NUT (13-15mm)	1
ITEM 3	S1324 13-15mm EXPANDER	1
ITEM 4	S0840 CONE SPACER FOR EXPANDER (13-15mm)	1
ITEM 5	S0781 CONE SPACER	1
ITEM 6	S0928 CLAMP SPACER	1
ITEM 7	M6 x 1.00 x 90.00mm COUNTER-SUNK BOLT	1

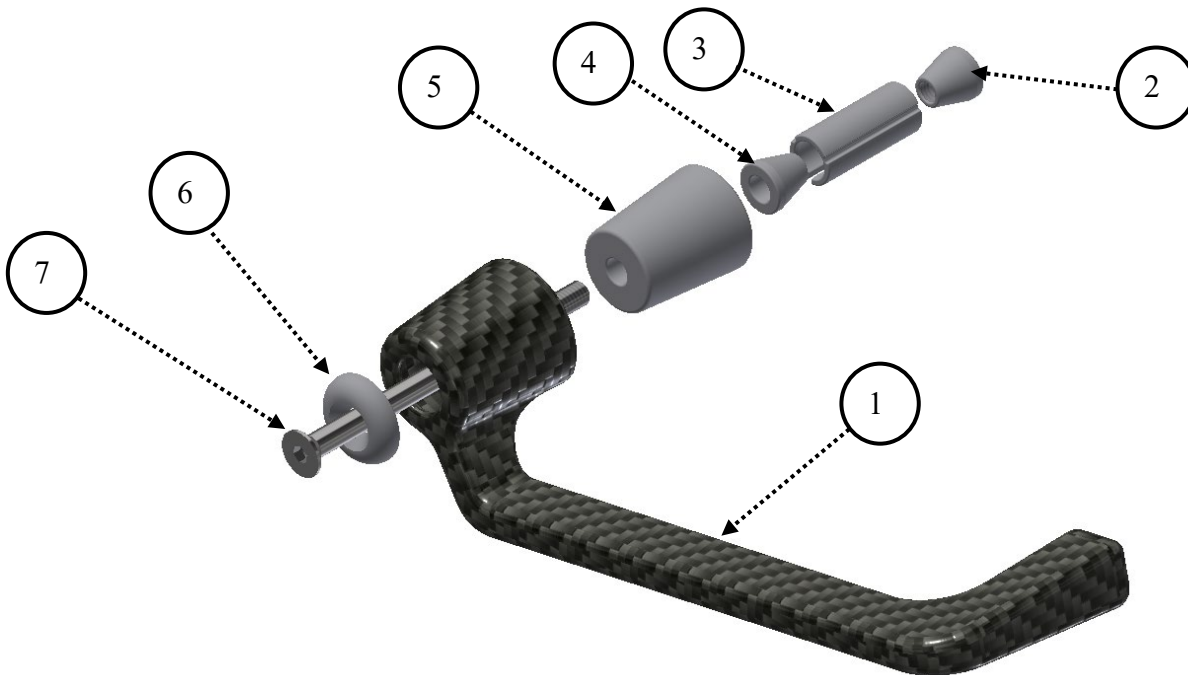

EXPLODED ASSEMBLY VIEW



FITTING INSTRUCTIONS

- To fit the R&G Brake Lever Guard, you will need to remove the original bar-end using the specific tools to your bike.
- Place the counter-sunk bolt (**item 7**) through the clamp spacer (**item 6**), then place the bolt and clamp spacer through the brake lever guard (**item 1**).
- Place the large cone spacer (**item 5**) over the exposed thread (so it sits into the lever guard).
- Place the smallest (unthreaded) cone spacer (**item 4**) over the exposed thread (so it sits against the large cone spacer).
- Place the expander (**item 3**) over the exposed thread (so it sits against the tapered spacer just fitted).
- Place the tapered nut (**item 2**) onto the thread and engage until it locates in the expander just fitted.
- Locate the assembly into the bar and position so when the motorcycle is at full lock in both directions it does not contact any other part of the motorcycle or **restrict throttle use**.
- Using a 4mm Allen tool, fully tighten the bolt and check operation.

IMPORTANT - WHEN FITTING THIS PRODUCT, IT IS YOUR RESPONSIBILITY TO ENSURE THAT THE PRODUCT IN NO WAY IMPEDES THE OPERATION OF THE MOTORCYCLE AND IS CHECKED REGULARLY FOR TIGHTNESS AND CORRECT OPERATION.

FAILURE TO CHECK THE ABOVE COULD RESULT IN SERIOUS INJURY OR DAMAGE.

ISSUE 1 – 10/01/2022

CONSUMER NOTICE

The catalogue description and any exhibition of samples are only broad indications of the Products and R&G may make design changes which do not diminish their performance or visual appeal and supplying them in such state shall conform to the order. The Buyer acknowledges no representation or warranty (other than as to title) has been given or will apply to the Products other than those in R&G's order or confirmation and the Buyer confirms it has chosen the Products as being of merchantable quality and suitable for its particular purposes. Where R&G fits the Products or undertakes other services it shall exercise reasonable skill and care and rectify any fault free of charge unless the workmanship has been disturbed. The Buyer is responsible for ensuring that the warranty on the motorcycle is not affected by the fitting of the Products. On return of any defective Products R&G shall at its option either supply a replacement or refund the purchase money but shall not be liable if the Products have been modified or used or maintained otherwise than in accordance with R&G's or manufacturer's instructions and good engineering practice or if the defect arises from accident or neglect. Other than identified above and subject to R&G not limiting its liability for causing death and personal injury, it shall not be liable for indirect or consequential loss and otherwise its liability shall be limited to the amounts paid by the Buyer for the Products or the fitting or service concerned. These terms do not affect the Buyer's statutory rights.

R&G RACING RETURNS POLICY (NON-FAULTY GOODS)

Returns must be pre-authorized (if not pre-authorized the return will be rejected). Goods may only be returned direct to us if they were purchased direct from us (customer must prove if necessary). Otherwise to be returned to original vendor. Goods must be in re-sellable condition, in the opinion of R&G Racing. All returns are subject to a 25% restocking and handling fee (25% of the gross value exc. P&P – at the prevailing price at time of purchase). The customer must pay any and all carriage charges. No returns of discontinued products, unless within 14 days of purchase. This policy does not affect your statutory rights and does not refer to faulty goods.

R&G Racing

Unit 1, Shelley's Lane, East Worldham, Alton, Hampshire, GU34 3AQ

Tel: +44 (0)1420 89007 Fax: +44 (0)1420 87301 www.rg-racing.com Email: info@rg-racing.com



INSTRUCTIONS DE MONTAGE POUR CLG0032CG/RH DEFENDER À LEVIER DE CARBONE
D'USINE
HOLLOW TUBE BARS 13-15MM MOST HONDA



CE KIT CONTIENT LES ARTICLES ILLUSTRÉS ET ÉTIQUETÉS SUR LA PAGE.

CERTAINES PARTIES PEUVENT ÊTRE PRÉSENTES UNIQUEMENT POUR LA CLARTÉ DES INSTRUCTIONS.

NE PAS PROCÉDER AU MONTAGE TANT QUE VOUS N'ÊTES PAS SÛR QUE TOUTES LES PIÈCES SOIENT PRÉSENTES.

VEUILLEZ LIRE TOUTES LES INSTRUCTIONS AVANT DE CONTINUER.

EN CAS DE DOUTE LORS DU MONTAGE DE NOS PRODUITS, CONSULTEZ UN DE NOS REVENDEURS OU FAITES APPEL À UN TECHNICIEN QUALIFIÉ.

VEUILLEZ NOTER QUE LA FAÇON DONT LE KIT EST EMBALLÉ NE REPRÉSENTE PAS NECESSAIREMENT LA MANIÈRE DE LE MONTER SUR LA MOTO.

SI DES RONDELLES EN CAOUTCHOUC SONT UTILISÉES POUR MAINTENIR LES COMPOSANTS SUR LES BOULONS, ELLES PEUVENT ÊTRE JETÉES.

NOTICE DISPONIBLE AU TÉLÉCHARGEMENT SUR :
WWW.RG-RACING.COM



<u>OUTILS REQUIS</u>	<u>VALEURS DE SERRAGE</u>
<ul style="list-style-type: none"> • CLÉ ALLEN 4mm. • OUTILS SPÉCIFIQUES POUR ENLEVER LES EXTRÉMITÉS DE GUIDON D'ORIGINE SI POSSIBLE. 	M4 BOULON = 8Nm M5 BOULON = 12Nm M6 BOULON = 15Nm M8 BOULON = 20Nm M10 BOULON = 40Nm M12 BOULON = 40Nm

LÉGENDE

ARTICLE NO.	DESCRIPTION	QTÉ
ARTICLE 1	PROTECTION POIGNEE EN FIBRE DE CARBONE (LG0005COMP).	1
ARTICLE 2	H0055 ÉCROU (13-15mm)	1
ARTICLE 3	S1324 13-15mm EXPANSEUR	1
ARTICLE 4	S0840 ENTRETOISE POUR EXPANSEUR (13-15mm)	1
ARTICLE 5	S0781 ENTRETOISE	1
ARTICLE 6	S0928 ENTRETOISE	1
ARTICLE 7	M6 x 1.00 x 90.00mm BOULON	1

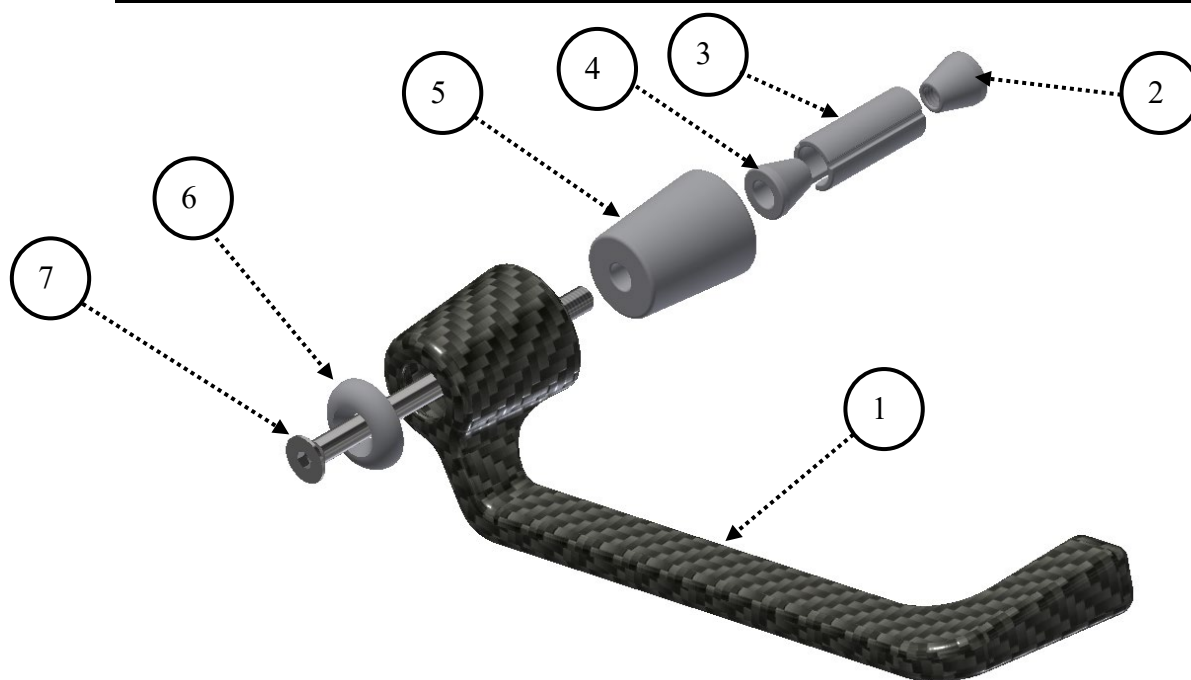

R&G Racing

Unit 1, Shelley's Lane, East Worldham, Alton, Hampshire, GU34 3AQ

Tel: +44 (0)1420 89007 Fax: +44 (0)1420 87301 www.rg-racing.com Email: info@rg-racing.com



VUE D'ENSEMBLE **NOTICE DE MONTAGE**

- Pour monter le protège-levier de frein R&G, vous devrez retirer l'embout de guidon d'origine à l'aide des outils spécifiques à votre moto.
- Placer le boulon à tête fraisée (article 7) à travers l'entretoise de serrage (article 6), puis placer le boulon et l'entretoise de serrage à travers la protection du levier de frein (article 1).
- Placez la grande entretoise conique (article 5) sur le filetage exposé (afin qu'elle s'insère dans le protège-levier).
- Placez la plus petite entretoise conique (non filetée) (article 4) sur le filetage exposé (afin qu'elle repose contre le protège-levier).
- Placer l'expandeur (article 3) sur le filetage exposé (afin qu'il repose contre l'entretoise conique qui vient d'être installée).
- Placer l'écrou conique (article 2) sur le filetage et l'engager jusqu'à ce qu'il se loge dans l'expandeur qui vient d'être mis en place.
- Placez l'ensemble dans le guidon et positionnez-le de sorte que lorsque la moto est complètement verrouillée dans les deux sens, il n'entre en contact avec aucune autre partie de la moto ou ne limite pas l'utilisation de l'accélérateur.
- À l'aide d'une clé Allen de 4 mm, serrez complètement le boulon et vérifiez le fonctionnement.

IMPORTANT - LORS DE L'INSTALLATION DE CE PRODUIT, IL EST DE VOTRE RESPONSABILITÉ DE VOUS ASSURER QUE LE PRODUIT NE PUISSE EN AUCUN CAS ALTÉRER LE FONCTIONNEMENT DE LA MOTO ET DE VÉRIFIER RÉGULIÈREMENT LE SERRAGE ET LE BON FONCTIONNEMENT.

NE PAS VÉRIFIER LES ÉLÉMENTS CI-DESSUS POURRAIT ENTRAÎNER DES BLESSURES OU DES DOMMAGES GRAVES.

ISSUE 1 – 10/01/2022

CONSUMER NOTICE

The catalogue description and any exhibition of samples are only broad indications of the Products and R&G may make design changes which do not diminish their performance or visual appeal and supplying them in such state shall conform to the order. The Buyer acknowledges no representation or warranty (other than as to title) has been given or will apply to the Products other than those in R&G's order or confirmation and the Buyer confirms it has chosen the Products as being of merchantable quality and suitable for its particular purposes. Where R&G fits the Products or undertakes other services it shall exercise reasonable skill and care and rectify any fault free of charge unless the workmanship has been disturbed. The Buyer is responsible for ensuring that the warranty on the motorcycle is not affected by the fitting of the Products. On return of any defective Products R&G shall at its option either supply a replacement or refund the purchase money but shall not be liable if the Products have been modified or used or maintained otherwise than in accordance with R&G's or manufacturer's instructions and good engineering practice or if the defect arises from accident or neglect. Other than identified above and subject to R&G not limiting its liability for causing death and personal injury, it shall not be liable for indirect or consequential loss and otherwise its liability shall be limited to the amounts paid by the Buyer for the Products or the fitting or service concerned. These terms do not affect the Buyer's statutory rights.

R&G RACING RETURNS POLICY (NON-FAULTY GOODS)

Returns must be pre-authorized (if not pre-authorized the return will be rejected). Goods may only be returned direct to us if they were purchased direct from us (customer must prove if necessary). Otherwise to be returned to original vendor. Goods must be in re-sellable condition, in the opinion of R&G Racing. All returns are subject to a 25% restocking and handling fee (25% of the gross value exc. P&P – at the prevailing price at time of purchase). The customer must pay any and all carriage charges.

R&G Racing

Unit 1, Shelley's Lane, East Worldham, Alton, Hampshire, GU34 3AQ

Tel: +44 (0)1420 89007 Fax: +44 (0)1420 87301 www.rg-racing.com Email: info@rg-racing.com



No returns of discontinued products, unless within 14 days of purchase. This policy does not affect your statutory rights and does not refer to faulty goods.