



KTM 790 Duke  
Crash Protection

Installation Instructions



## Kit Contents PRN013992

- |                                 |                                   |
|---------------------------------|-----------------------------------|
| Ⓐ 1 x L/H Main Bracket          | ⓙ 1 x M12 x 95mm x 1.25 Caphead   |
| Ⓑ 1 x L/H Spacer (Long)         | Ⓚ 1 x Cross Support Bar           |
| Ⓒ 1 x L/H Cable Bracket         | Ⓛ 2 x M8 x 25mm Caphead           |
| Ⓓ 1 x R/H Main Bracket          | Ⓜ 2 x M10 x 35mm Caphead          |
| Ⓔ 1 x R/H Spacer (Short)        | Ⓝ 2 x M8 x 10mm Black Button Head |
| Ⓕ 1 x R/H Cable Bracket         | Ⓞ 2 x M12 Washer                  |
| Ⓖ 1 x M10 x 90mm Caphead        | Ⓟ 2 x Polyurathane Washer         |
| Ⓗ 1 x M10 x 75mm Caphead        | Ⓠ 2 x Bobbin Heads                |
| Ⓘ 1 x M12 x 85mm x 1.25 Caphead | Ⓡ 3 x Cable Ties                  |

K

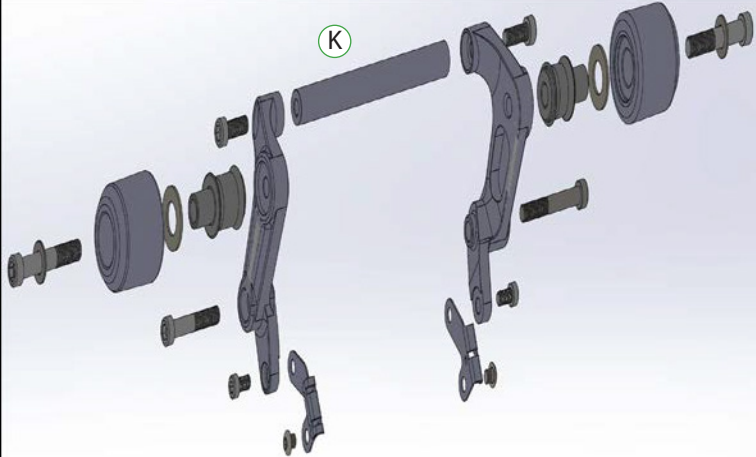

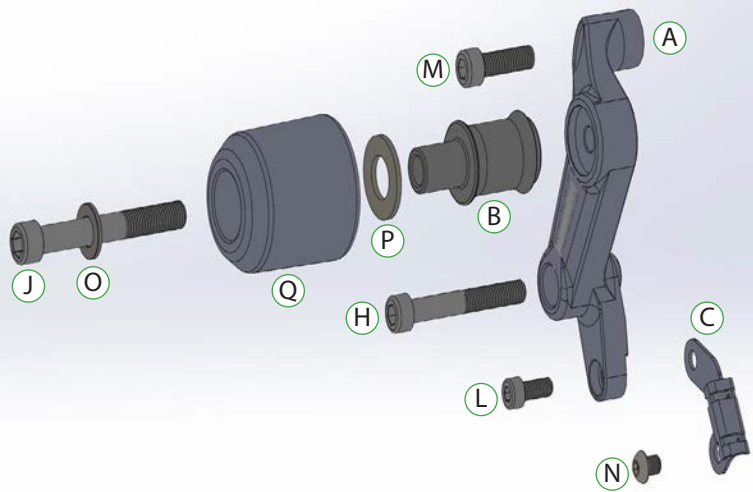

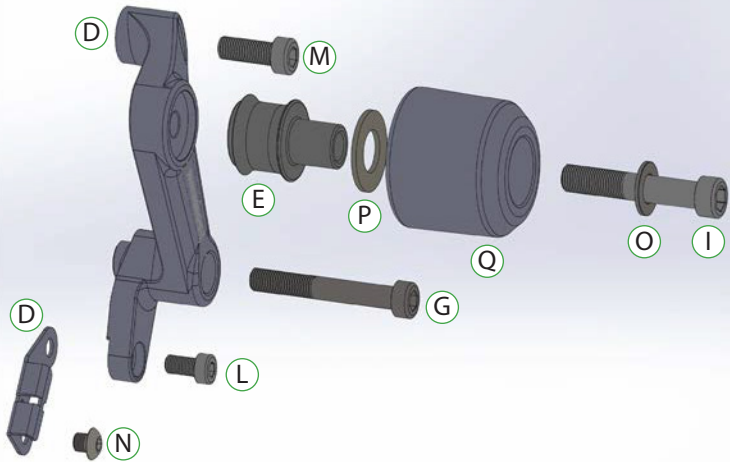

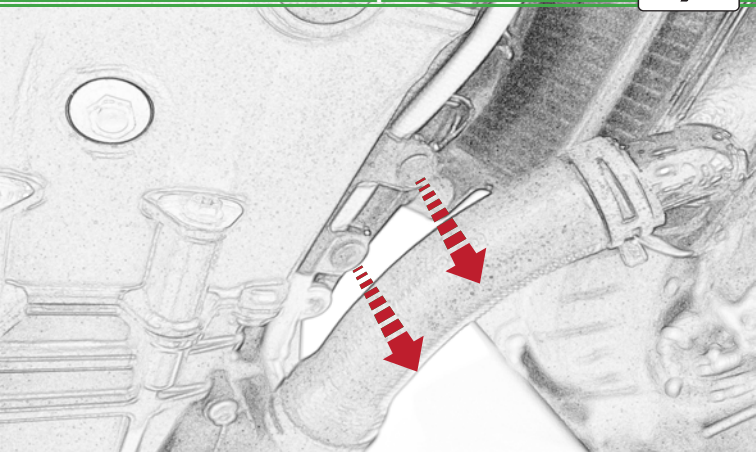

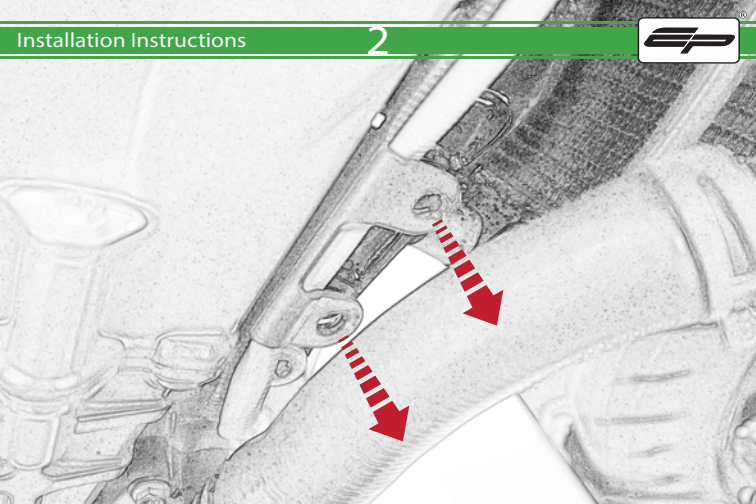

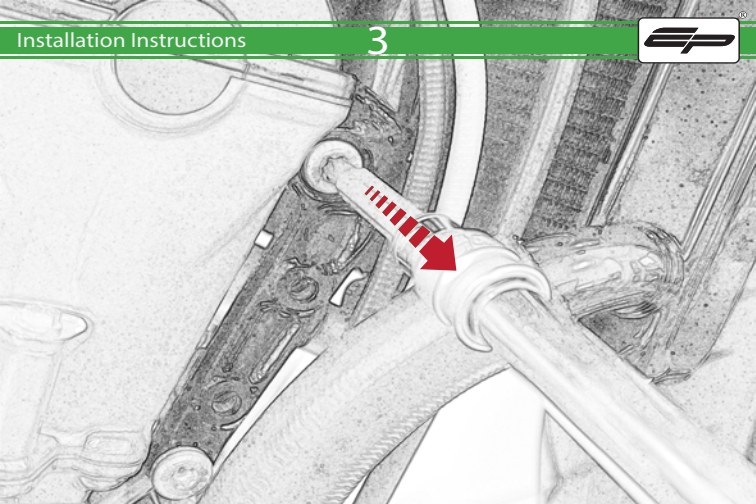



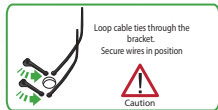
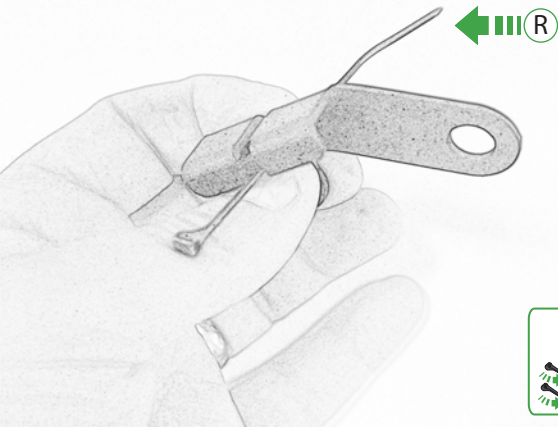

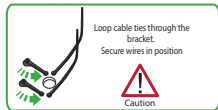
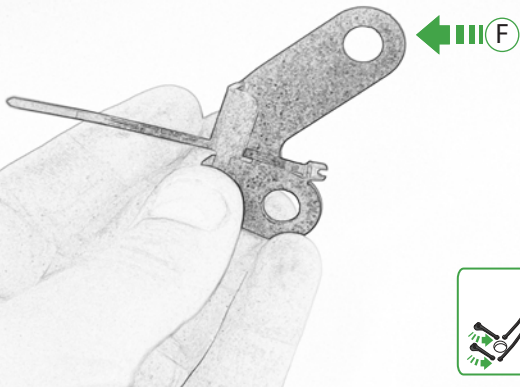

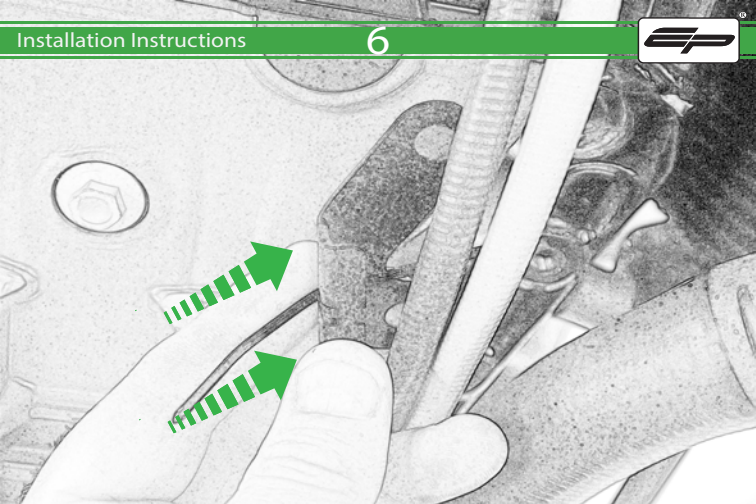

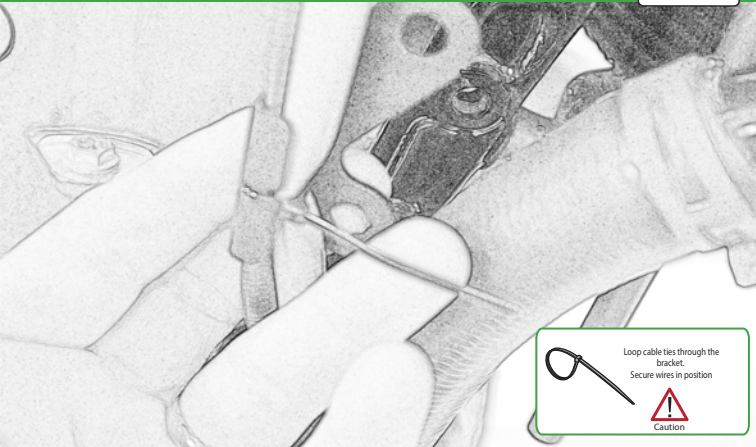

Loop cable ties through the bracket.

Secure wires in position



Caution

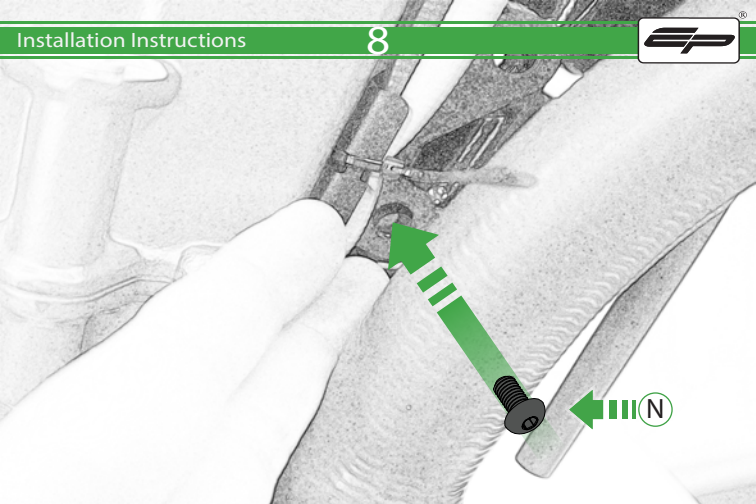

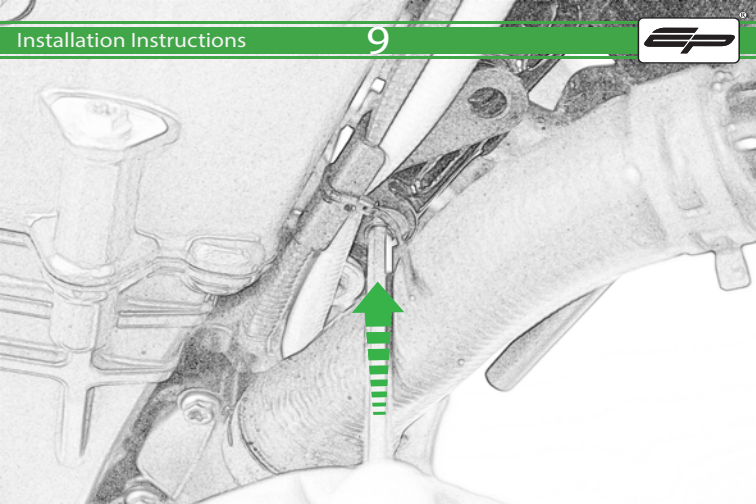

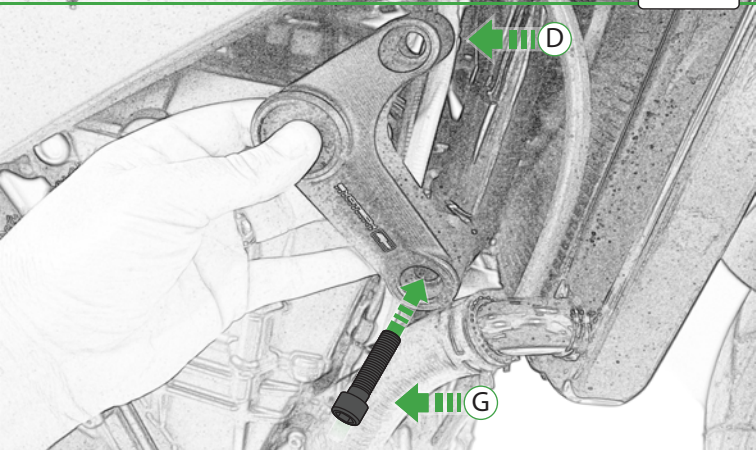

D

G

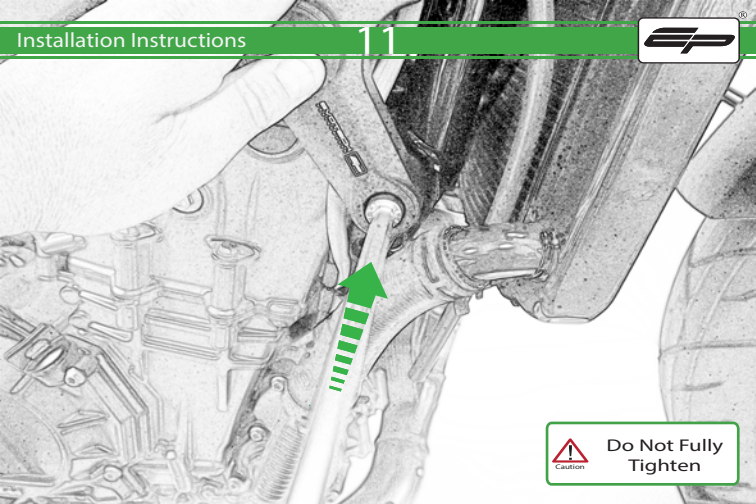

Caution

Do Not Fully Tighten



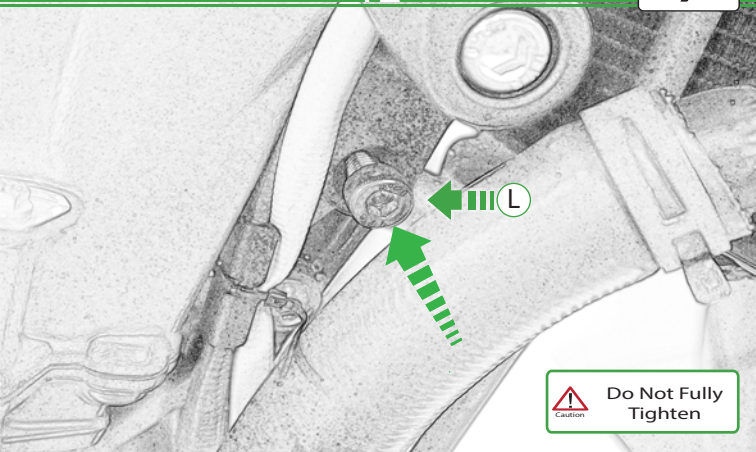

Caution

Do Not Fully Tighten

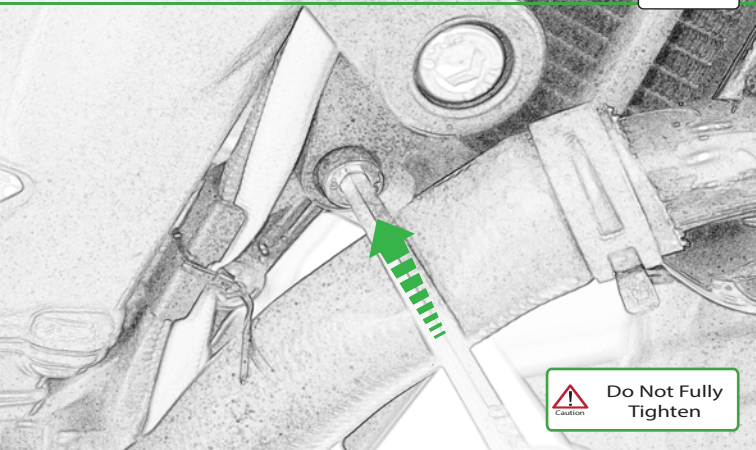

Do Not Fully Tighten

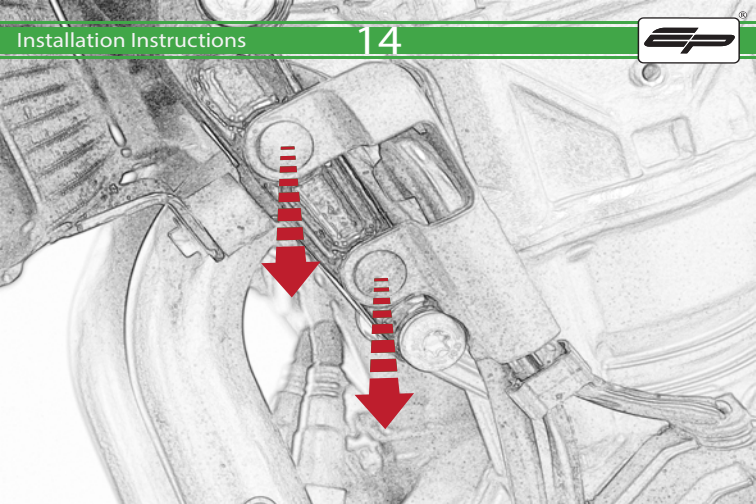

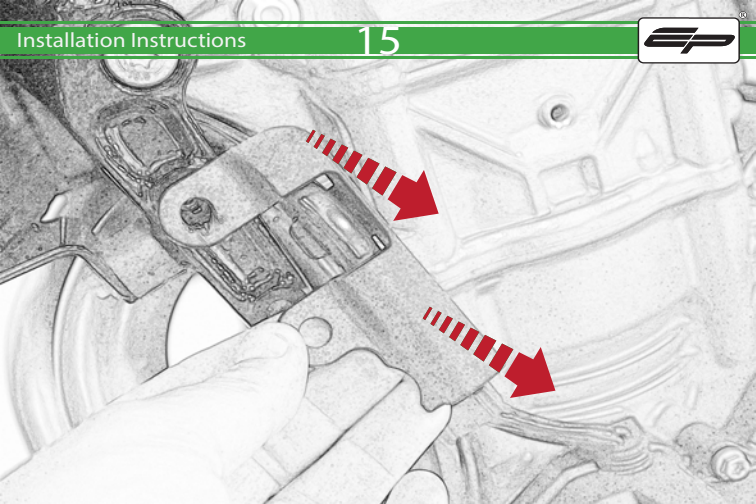

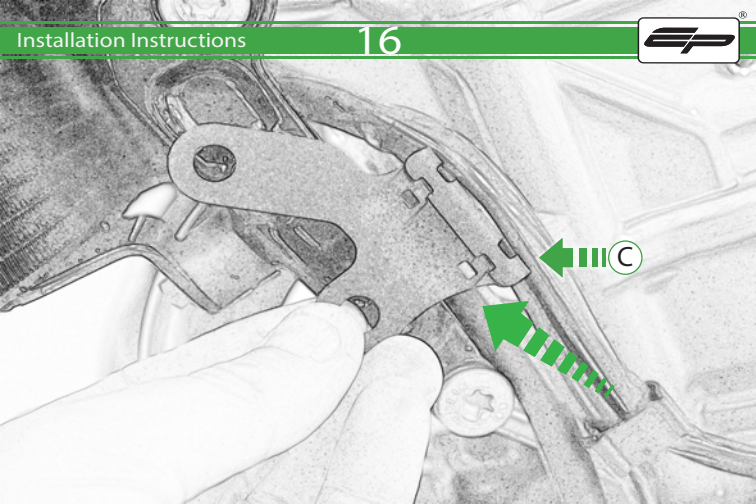

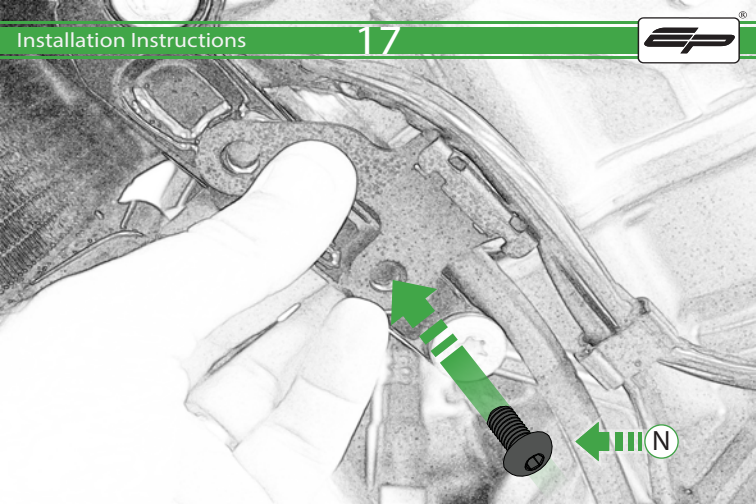

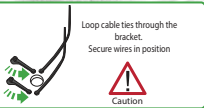

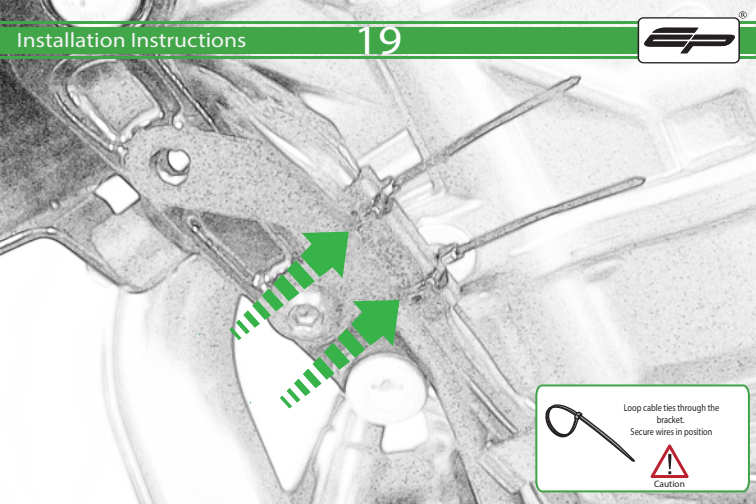

Loop cable ties through the bracket.

Secure wires in position



Caution



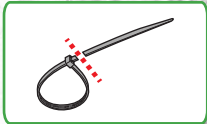
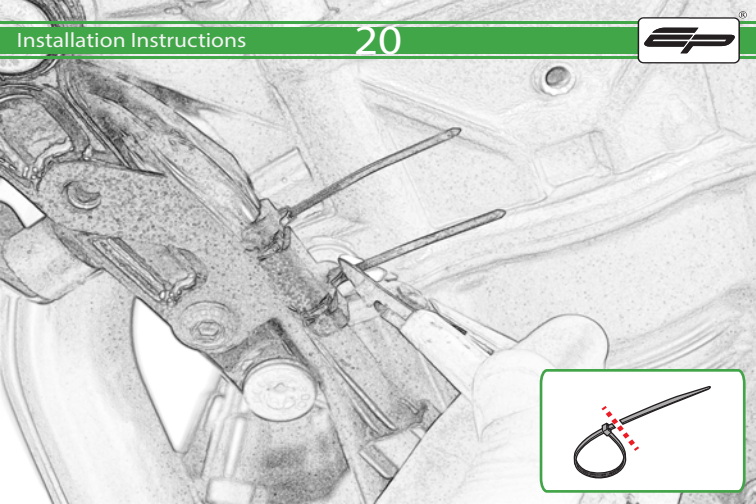

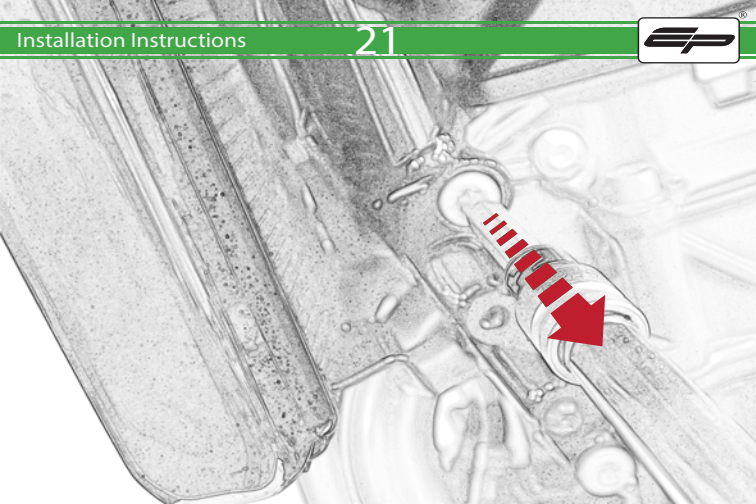

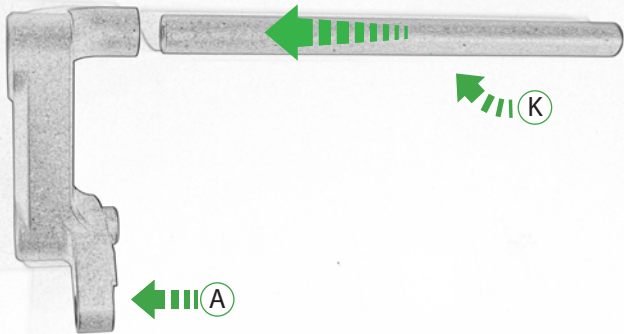

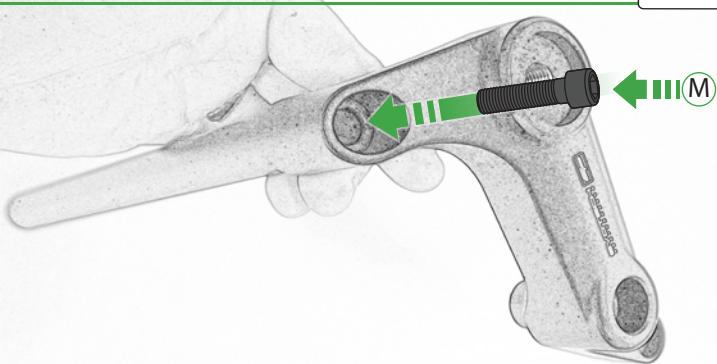

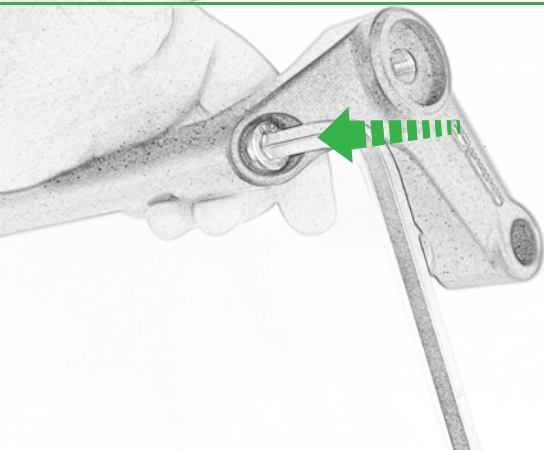



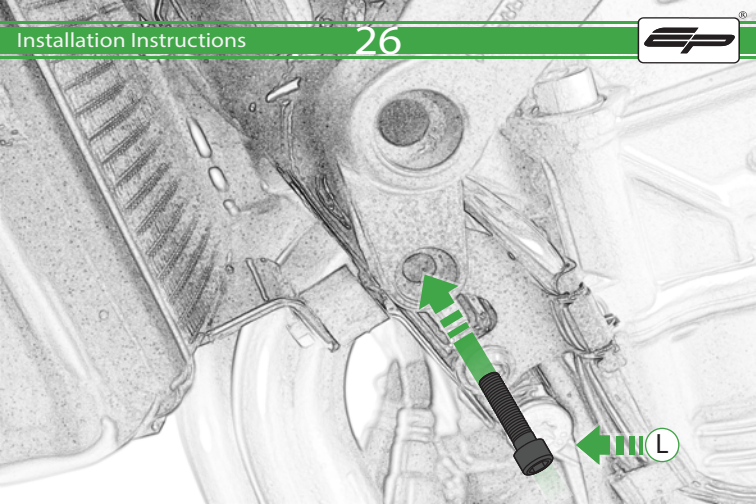

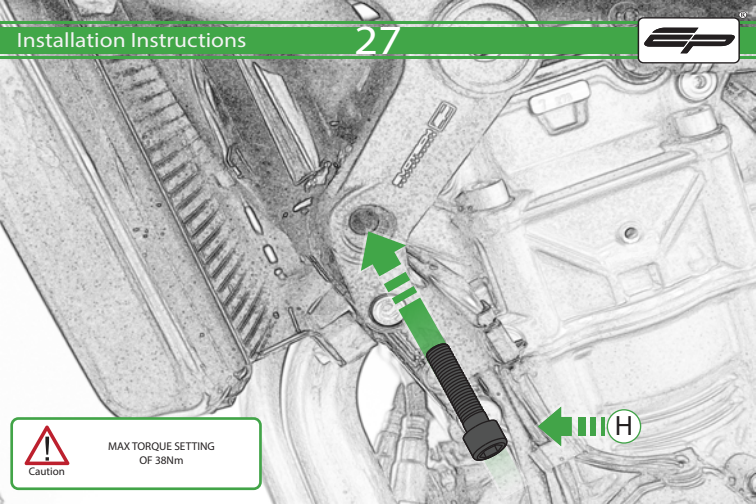

Caution

MAX TORQUE SETTING  
OF 38Nm







Caution

MAX TORQUE SETTING  
OF 38Nm



Caution

Fully  
Tighten

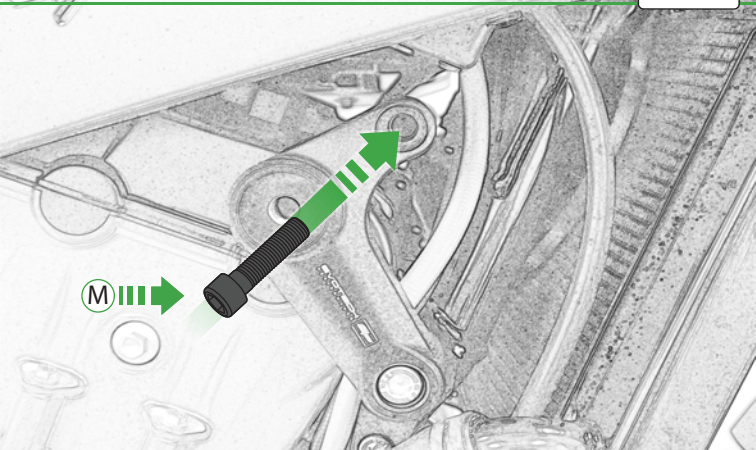

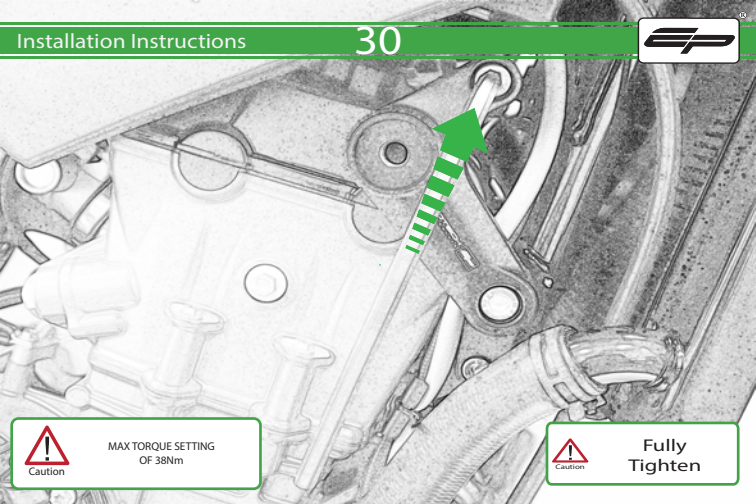

Caution

MAX TORQUE SETTING  
OF 38Nm



Caution

Fully  
Tighten

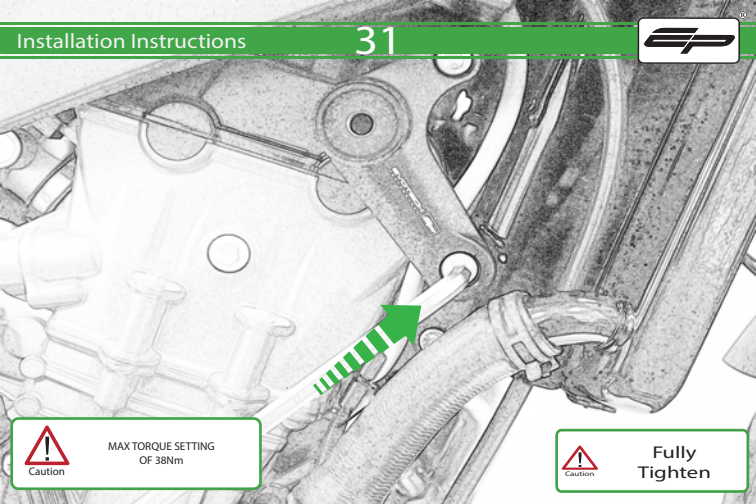

Caution

MAX TORQUE SETTING  
OF 38Nm



Caution

Fully  
Tighten

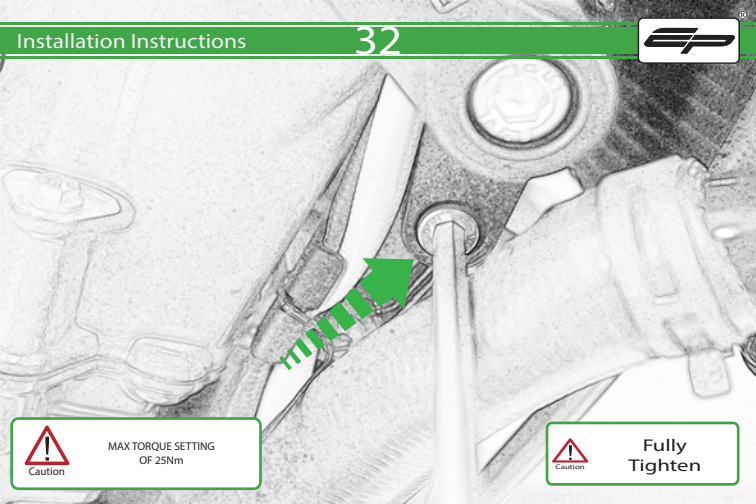

Caution

MAX TORQUE SETTING  
OF 25Nm



Caution

Fully  
Tighten

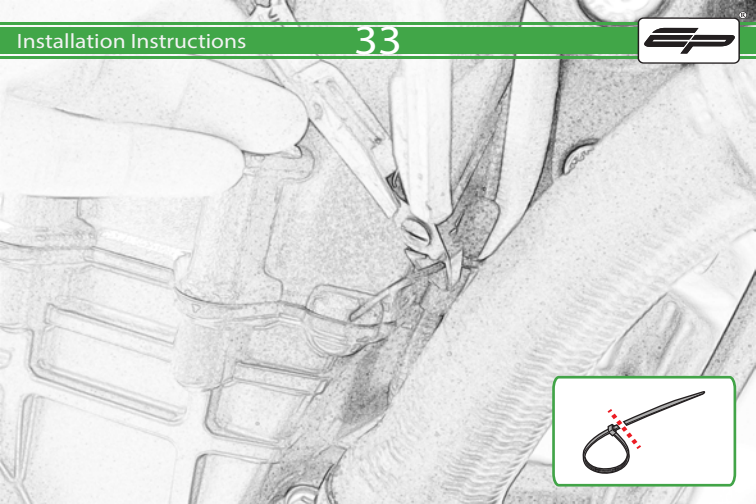

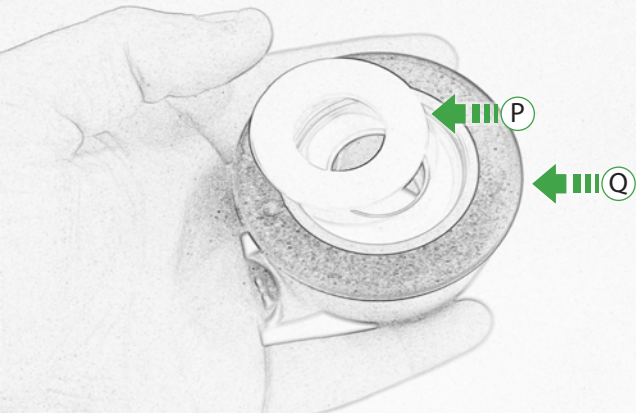

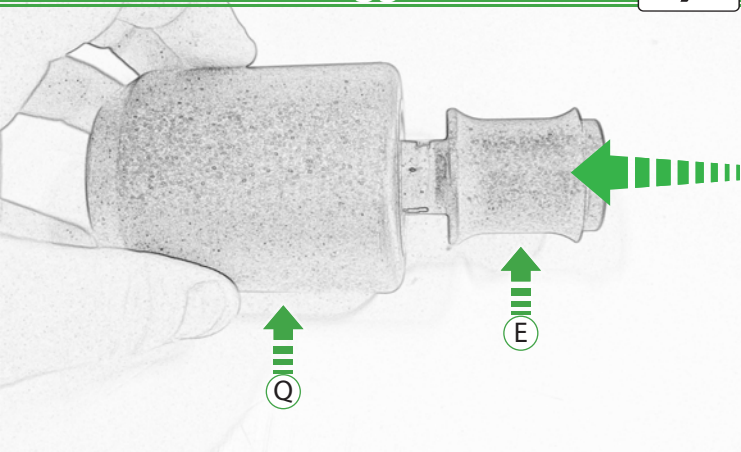





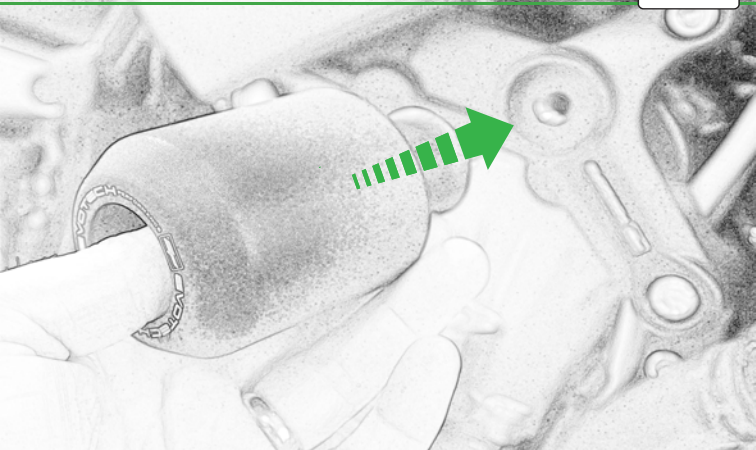



Caution

MAX TORQUE SETTING  
OF 45Nm



Caution

Fully  
Tighten

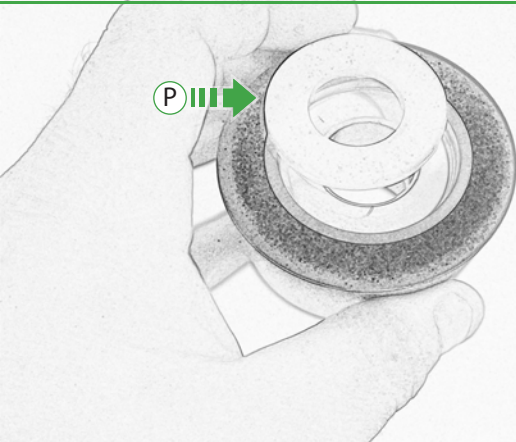

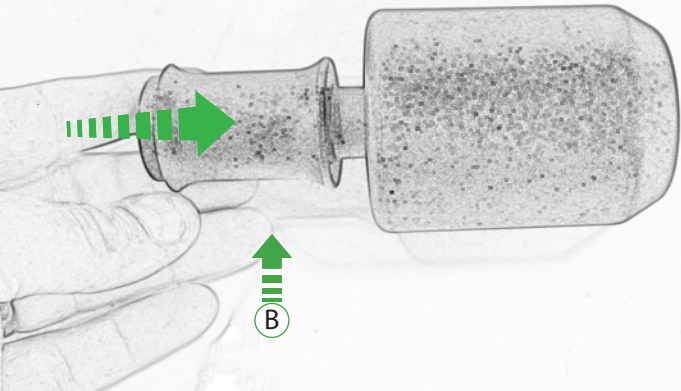

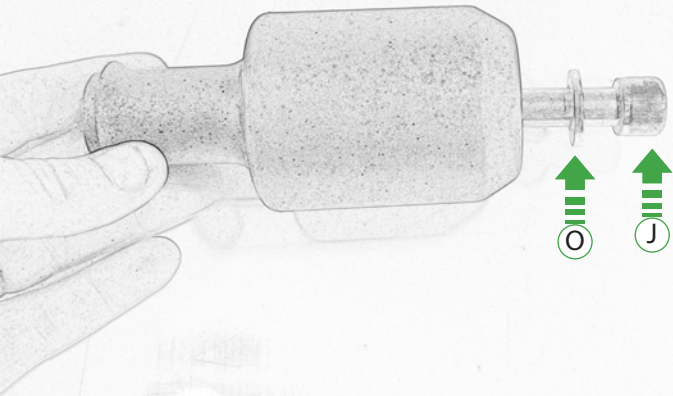



Caution

MAX TORQUE SETTING  
OF 45Nm



Caution

Fully  
Tighten

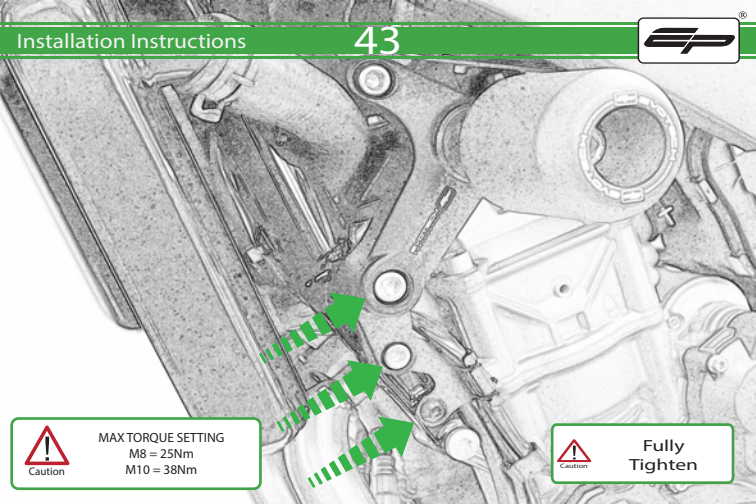

Caution

MAX TORQUE SETTING

M8 = 25Nm

M10 = 38Nm



Caution

Fully  
Tighten



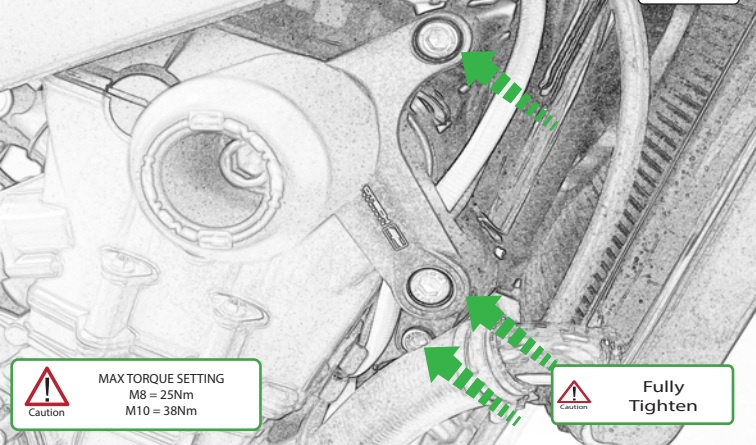

Caution

MAX TORQUE SETTING

M8 = 25Nm

M10 = 38Nm



Caution

Fully  
Tighten

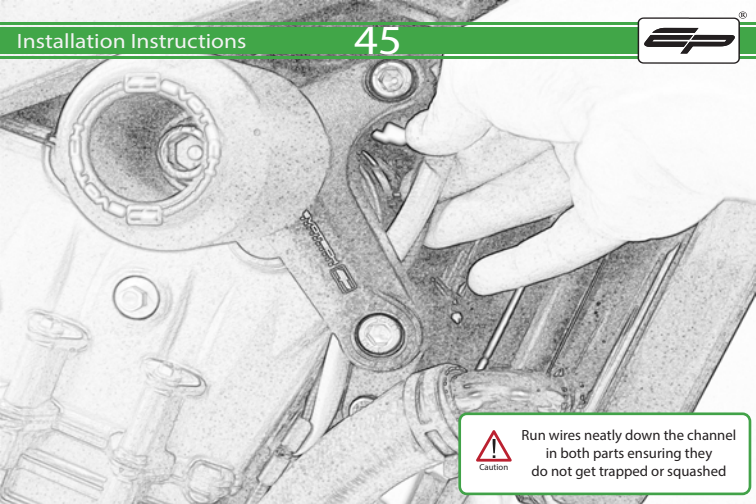

Run wires neatly down the channel in both parts ensuring they do not get trapped or squashed



 **ESSENTIAL CHECKS** 

It is recommended that periodic inspections are made to ensure that all bolts are tightened to the specified torque settings.

Should the bike be involved in an accident a thorough inspection should be made and any components that have taken an impact, no matter how small, be replaced



**EVOTECH**®  
P E R F O R M A N C E

[www.evotech-performance.com](http://www.evotech-performance.com)