



# STEEEDA

## 2020+ Steeda Hardcore Explorer Differential Mount 555-8141

### Tool required:

E18 Star Torx Socket

15mm Socket

13mm Wrench

10mm Allen Key

5mm Allen Key

**Note:** We strongly recommend that a factory shop manual be available for reference during the installation. If you are not confident you can complete the job safely, have the work performed by a certified technician. **This kit comes with the soft red bushing option installed. Harder black bushings are also included but might cause NVH.**

1. Lift the vehicle on a lift or on jack stands to work on the rear differential. Use caution operating a lift or jack stands to ensure the SUV is stable and safe to work around and underneath.
2. Remove the four lower diff bolts using a E18 star torx socket. Then loosen the two bolts on each side just above these four with a 13mm wrench. Loosen about 5/8". See pic 1
3. Slide the Steeda diff mount bracket under the two loosened bolts. Install the provided 70mm long bolts with a 15mm socket in place of the four bolts you removed. Tighten the factory bolts with a 13mm wrench. Torque all bolts to 25ftlbs. See pic 2

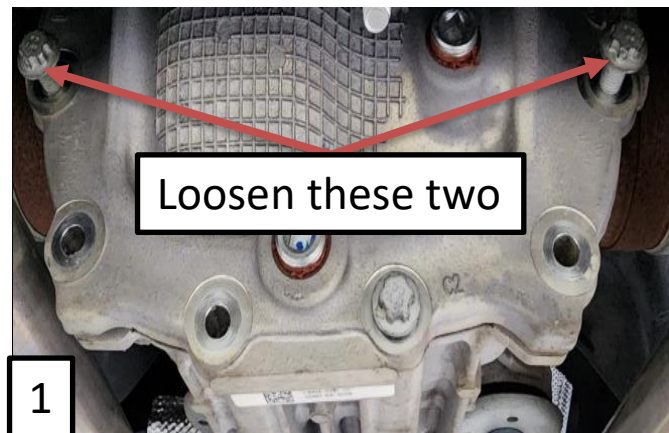
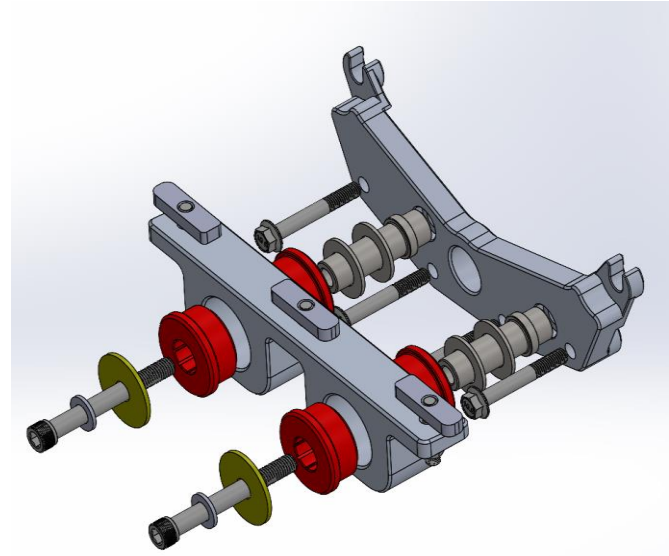



# STEEDA



4. Insert one of the Steeda provided frame connector plates into the three slotted holes.
5. Raise the subframe bushing assembly over the three hanging studs (the slope should be facing towards the diff, see pic 3), while rotating the two bushing pins into the pockets of the diff mount bracket. Place the 2" and small washers over the two blue 12mm socket cap bolts and loosely thread them through the bushings and into the diff bracket. This will hold the assembly in place.
6. Using blue Loctite, with a 5 mm Allen wrench, thread the 10mm set screw into each plate 10 turns. A screwdriver might help align the holes.
7. Now tighten the two blue 12mm socket cap bolts to 60ftlbs. See pic 7
8. Then start the three flanged nuts by hand, on the three hanging studs. Using a 15mm wrench (a ratchet wrench works best) and 5mm Allen key, tighten the three nuts. The Allen key will keep the stud from spinning while you tighten the nut with the wrench to 45ftlbs. See pic 4&5
9. We suggest checking the torque of all the bolts after 100 miles. Enjoy!

