

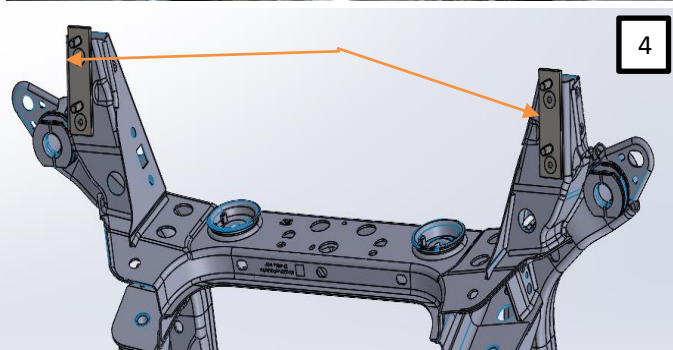
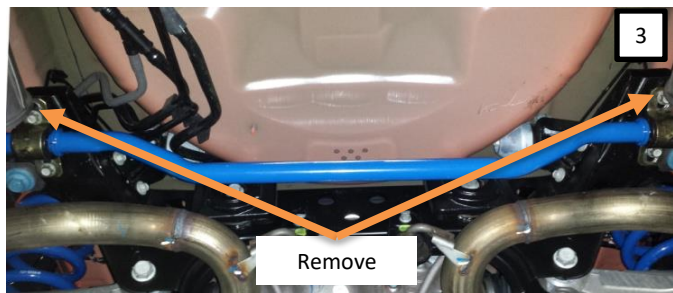

MADE IN AMERICA
STEEDA
S550 Mustang Rear
Competition Swaybar

Instructions for 555-1034

Stock Swaybar Removal

1. Raise the rear of the car off the ground by the chassis, and place on jack stands (if not using a hoist), so that the rear tires are at least a foot off of the ground at full suspension droop. Use caution operating a lift, or jack stands, to ensure the car is stable and safe to work around and underneath.
2. Remove the rear wheels.
3. On both sides, disassemble the rear brake line mounting brackets. Remove the 8mm bolt from the bracket, shown in Figure 1.
4. Remove the factory rear swaybar endlinks, by removing the thru bolt from the endlink. It has a 6mm Allen head stud, and an 18mm nut. With the nut removed, pull the endlink out of the swaybar. See Figure 2.
5. Remove the four (two for each bracket) 13mm bolts securing the steel swaybar bushing brackets to the subframe. See Figure 3.
6. Maneuver the swaybar, with bushings and brackets still attached, through the subframe, exhaust, and suspension and out through the driver or passenger side of the car.
7. Place the provided Steeda relocation brackets on the frame using the provided bolts. You're relocating the bar further back. See Figure 4.



Steeda Swaybar Installation

7. Maneuver the Steeda rear swaybar into the same location and orientation of the factory swaybar.
8. With the provided grease, liberally grease the inside of the new swaybar bushings. Install the swaybar bushings over the swaybar.
9. Slide the provided steel bushing brackets over the swaybar bushings. See Figure 6.
10. By hand, start all four provided swaybar bushing bracket nuts into the relocation bracket before tightening. See Figure 5.
11. Install the provided 7/8" lockout collars inside and against of each swaybar bushings, approximately 29.360" apart. Tighten with red loctite. See Figure 5
12. Install the supplied rear brake line bracket as shown in Figure 3, using the factory bolt and supplied nut.
13. Install the swaybar end links into the desired hole, and make sure the same holes are used on both sides. The hole on the swaybar that is closest to the rear of the car, provides the stiffest setting.
14. Tighten the end link studs to 65ft-lbs.
15. Tighten the swaybar bushing brackets to factory specs, around 35-40ft-lbs.

