

PIEZORESISTIVE PRESSURE MINI TRANSDUCER SPxx-M8

Piezoresistive Pressure Mini Transducer, linear analogue output, amplified, designed for all motorsport applications: brakes, oil, water or fuel; stainless steel body. Ergal junction for fitting sensor on banjo screw available as optional. Body structure and diaphragm are resistant to standard motorsport fluids.
 Viton version available on request for hermetic applications.
 Custom calibration available on request.



Cod.	Range (Bar)	Type	Overpressure	Compensation
SP10-M8x1	0÷10	Relative	20 bar	Standard
SPA10T-M8x1	0÷10	Absolute	20 bar	± 1 %FS (0...120 °C)
SP35-M8x1	0÷35	Relative	70 bar	Standard
SP35T-M8x1	0÷35	Relative	70 bar	± 1 %FS (0...120 °C)
SP60-M8x1	0÷60	Relative	120 bar	Standard
SP80-M8x1	0÷80	Relative	160 bar	Standard
SP60-M8x1.25 FB	0÷60	Relative	120 bar	Standard
SP150-M8x1	0÷150	Relative	300 bar	Standard

TECHNICAL SPECIFICATIONS:

- ◆ Power Supply: 8÷28 V
- ◆ Output voltage: 0,5 V...4,5V NOT ratiometric
- ◆ Current consumption: 3,5mA
- ◆ Linearization: 0,5 V = 0 _____ 4,5 V = FS
- ◆ Accuracy (Comp. Temp-Range): Standard ± 1,5 %FS (-10...80 °C)
 Optional ± 1 %FS (0...120 °C)
- ◆ Frequency: 2 KHz
- ◆ Temperature Range: -20...120 °C
- ◆ Sealing: O-Ring Viton Ø 9x1,5 (only M8x1 model)
- ◆ Thread: M8x1/M8x1.25
- ◆ MAX tightening torque: 7 Nm
- ◆ Sealing: IP67
- ◆ Weight: ≈ 34 g
- ◆ Cable length: 600mm with DR25 & HFT
- ◆ Connections: awg24 BLACK GND
 awg24 RED Supply
 awg24 GREEN Signal
 Motorsport connector upon request.

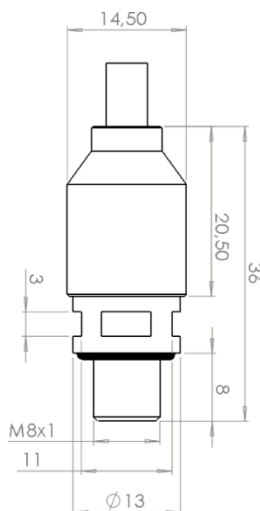

M8x1

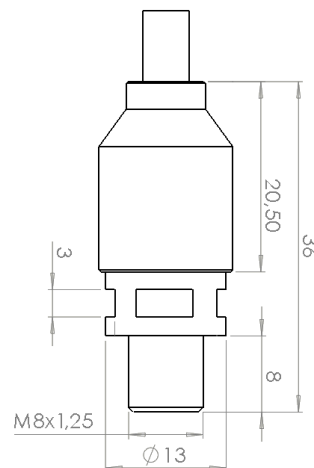
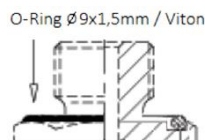

M8x1.25

