

# DYU SMART ELECTRIC BIKE S2 INSTRUCTION

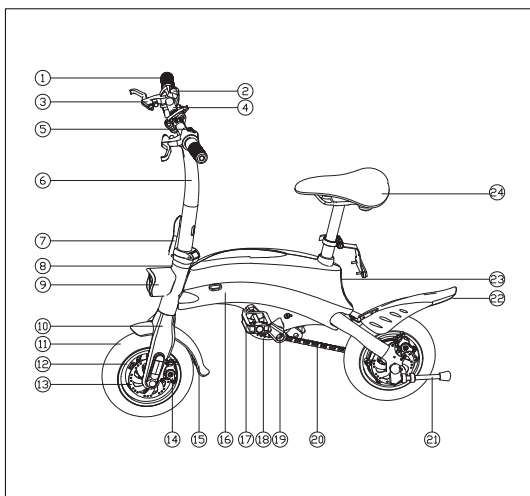

By F-Wheel

# INSTRUCTIONS FOR THE USE OF SMART MINI EBIKES



1. Gear Shift
2. Dashboard
3. Brake handle
4. Handle bar
5. Light Switch
6. Vertical pole
7. Folding buckle
8. Pole Head (where the bike ID code was engraved)
9. Front light
10. Front fork
11. Tire
12. Front hub
13. Disc brake plate
14. Disc brake device
15. Front fender
16. Battery case (unremovable)
17. Pedal
18. Chain Crank
19. Chain Wheel
20. Chain
21. Stand
22. Back fender
23. Back light
24. Seat Cushion

Note: Due to the company's product upgrade, some details of the product you get may be different from this picture, but it will not affect your normal use.

## PARTS LIST

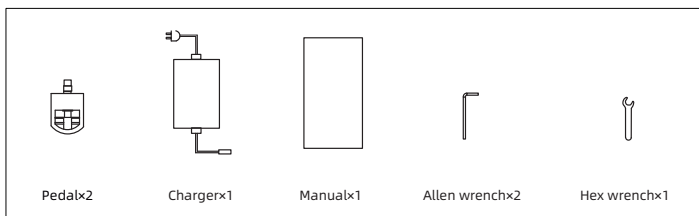

## Folding Picture:



1. Before folding

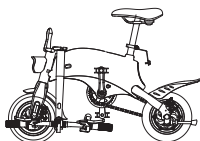

2. After folding

## Install the pedals:

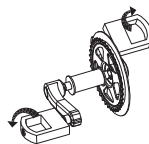

Right foot pedal:  
rotate clockwise to install  
Left foot pedal:  
rotate counterclockwise to install

## FUNCTION INTRODUCTION

1. Install the handlebar after unpacking, straighten and release the quick-release handle, adjust the horizontal handle to the appropriate direction, then press the quick-release, gently hold the brake lever a few times, and use it after the brake line returns to the best state, then install the foot pedal.

2. Charging: Connect the charger and start charging. When the indicator light of the charger changes from red to yellow-green, continue charging for one hour more.

3. Switch on: Pressing the power switch directly to turn on.

4. Switch off: Pressing the power switch directly to turn off, the dashboard won't work after switch off.

5. Power indicator: There are four levels of power indicator on the meter, which correspond to high power, medium power and low power respectively.

6. Horn: Switch on the left side of the handlebar. After pressing the horn button, the horn starts to sound. It is recommended to click. If you continue to press the horn button, the horn will stop automatically after 10 seconds. Please release it before using it.

7. Headlight: ON/OFF on the left side of the handlebar is a light switch.

8. Brakes and back light: The brakes cannot be accelerated when the brakes are not fully rebound. The night running lights and the front lights are switched synchronously. The brake lights are bright when braking.

9. Electric and power-assisted: the maximum design speed of electric is 25km/h (default value) (the load, road conditions and power state are different), hold the brake, turn the throttle to the end and then turn on, you can switch the maximum speed limit 20/25 h), single gear boost.

10. Cruise at fixed speed: During electric driving, turn the accelerator to hold for 5~8 seconds and then release, you can drive at a constant speed at the current speed, turn the accelerator or brake again to cancel the cruise.

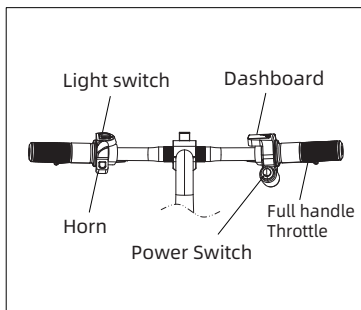
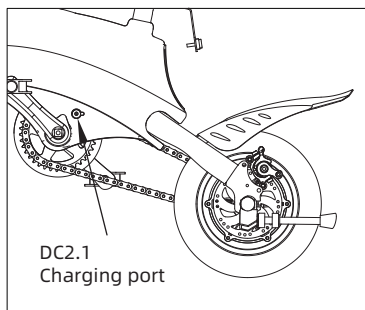

## PRODUCT PARAMETERS

Product Dimension	Model	DYU S2
	Bike frame material	Metal
	Folding size	960*220*680mm
	Unfolding size	960*490*915mm
	Packing size	1000*220*550mm
	Center distance of front and rear wheels	700mm
	Foot-off height	130mm
	Wheel size: 10inch	10inch
	Product colors	black
Performance parameters	Bike weight	17kg
	Weight Capacity	120kg
	Riding speed	20km/h
	Max speed	25km/h
	Power consumption per hundred kilometers	1.1kWh
	Electric endurance	40Km
	Boost battery life	50km
	Maximum climbing angle	15°
	Operating temperature	10~45°
	Waterproof level	IP54

## PRODUCT PARAMETERS

Accessories parameters	Model	DYU S2
	Battery type	Lithium battery
	Battery capacity	10Ah
	Battery approved voltage	DC36V
	Charging voltage	DC42V
	Charger input voltage	AC220V
	Charging time	6H
	Motor type	Brushless DC motor
	Motor rated power	240W
	Motor rated speed	460r/min
	Motor rated voltage	36V
	Controller undervoltage value	31±1V
	Controller current limit value	15±1A
	Battery insurance tube	main insurance 30A secondary insurance 10A
Features	Anti-theft positioning	None
	APP (Smart APP)	None
	Headlight	Yes
	Taillight	Yes
	Seat height	adjustable
	Fixed speed cruise	8 seconds fixed speed cruise
	Braking method	front and rear disc brakes

Remarks: Electricity, load, tire pressure, road environment, chain and axle shaft lubrication will affect the maximum speed; the continuation mileage is at 25°, load 60 kg, speed 15~20km/h, smooth hard surface, from fully charged The battery is completely depleted and measured by continuous testing; factors such as driving habits, temperature, load, tire pressure, and road environment will affect the mileage.

# CIRCUIT SCHEMATIC

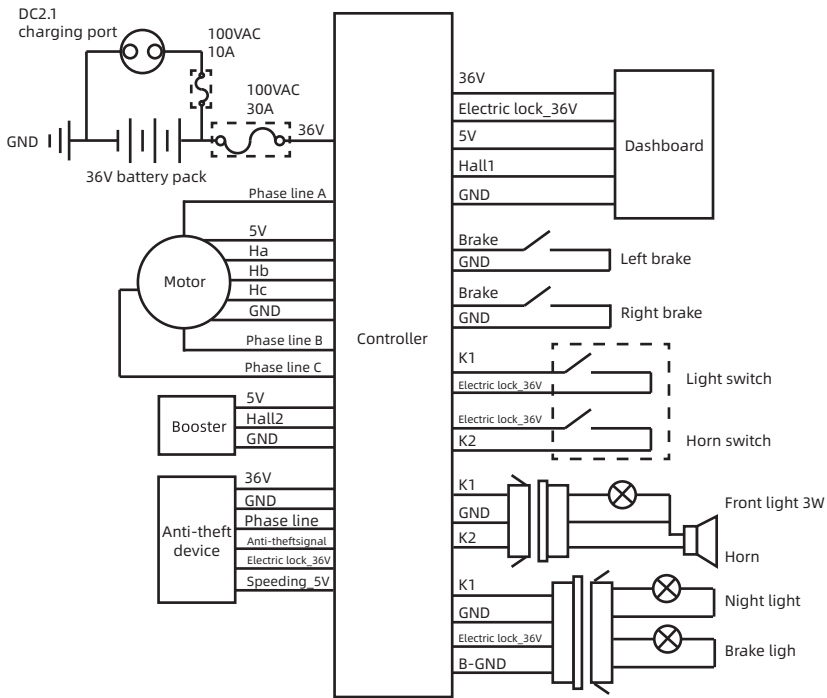

## PRECAUTIONS

### Battery and charging:

Charge at 0°~ 45°, discharge at -10°~ 45°, keep the battery dry. The negative pole is reversed, and it is strictly forbidden to destroy, disassemble or disassemble the battery or short-circuit the battery. When charging, please use the original special charger. It is strictly forbidden to use other chargers. Do not exceed 6 hours. The charging current does not exceed 2A. When not in use for a long time, please keep the battery in a cool and dry place and charge the battery for two hours every month. The user must follow the instructions for use when charging, otherwise the consequences will be at your own risk. Pay attention to the type of battery and the applicable voltage that the charger can charge, and it is strictly forbidden to mix. When charging, it should be placed in a ventilated environment. It is strictly forbidden to charge in confined spaces or high temperature environments. When charging, insert the battery first, then add the city power; after charging, cut off the city power first, and then pull out the battery plug. When the green light is on, the power supply should be cut off in time. It is forbidden to connect the charger to the AC power supply without load for a long time without charging. During the charging process, if the indicator is abnormal, there is an odor, or the charger case is overheated, you should stop charging immediately, and repair or replace the charger. Used batteries are hazardous chemicals. It is not allowed to dismantle used batteries without authorization, and the relevant professional departments shall organize the recycling. In the process of use and storage, pay attention to avoid the entry of foreign objects, especially to avoid the inflow of water or other liquids, so as not to cause a short circuit inside the charger. The charger should not be carried with the vehicle as much as possible. If it is indeed necessary to carry it, it should be placed in the tool box after shock absorption treatment. Do not disassemble or replace the components in the charger.

### Riding:

Do not use it until you read the instructions carefully and understand the performance of the product;  
Do not lend this product to people who will not operate it, so as not to cause injury;  
Please wear a safety helmet when riding a bicycle, and abide by the traffic rules. It is not allowed to exercise on motor vehicle lanes and roads with many pedestrians;  
Carry personnel or articles in accordance with the requirements of laws and regulations, do not park in the building entrance hall, evacuation stairs, walkways and safe entrances and exits;  
Do not charge and park in residential buildings. Keep away from combustible materials when charging. The charging time should not be too long;  
Drive on the right in non-motorized lanes, downhill and paved roads not exceeding 15km/h, and drive on the right when there is no non-motorized lane;  
When adjusting the handlebar or saddle, be careful not to leak the safety line marks of the stem and saddle tube;  
Before riding, check whether the front and rear brakes are working properly, check the tightening status of the handlebars and front and rear wheels, and check whether the reflector is damaged or polluted;  
When using the motor, please pay attention to avoid strong impact and keep the shaft lubricated;  
It is not allowed to ride more than the maximum negative weight of the car body (maximum load 120KG);  
If you ride in rain or snow, the braking distance will be extended. Pay attention to slow down;  
Try to avoid trips in bad weather such as heavy rain;

**One-handed riding is prohibited, please wear a helmet, suitable for people 16 to 45 years old, and persons under 16 years old are strictly prohibited to drive electric bicycles on the road.**

### Maintenance and maintenance:

The front and rear wheels of the vehicle should be located in the center of the front fork or frame;  
After riding, please store the car in a place free of sunlight and rain;  
It is forbidden to rinse with water, you can use a semi-dry cloth to wipe the body surface;  
Check the motor and brakes frequently, and do not fill the brakes with oil;  
Regularly check the various screws of the car and the places to be tightened, and strengthen them regularly;  
Recommended torque: (Unit: kgf.cm) 60-80 horizontal screws, 175-200 vertical screws, 175-250 seat cushion screws, 320-450 wheel screws;  
Regularly check the tension of the chain, which can be adjusted by the chain regulator;  
Always check the tires for scars, cracks, or excessive wear. The inner tube and valve should be perpendicular to the hub and not skewed.  
Accidentally punctured damaged or excessively worn inner and outer tires need to be replaced immediately, please find a professional technician to repair or replace your tires.  
It is forbidden to modify the key structural parts and electrical function accessories such as the frame, front fork, vertical tube, etc. If they are damaged, they must be replaced with original accessories. Otherwise, three guarantees will not be provided.

Three guarantees service, any loss or damage caused by modification shall be at your own risk.

**Responsibility statement:**

- The product model, specifications or related information mentioned in this manual, the company reserves the right to modify and final interpretation;
- The functions of the specific model mentioned in this manual are only applicable to the specific model;
- The product model, specifications or related information mentioned in this manual are subject to any modification or change without prior notice;
- Without the prior written permission of the company, it is not allowed to copy, modify, reprint, disseminate or publish the contents of the manual in any form;
- Please read this user manual carefully before using the product, and follow the operation manual, otherwise the product damage due to improper use or error or personal and property losses, the company does not assume responsibility.
- For product related information, please visit the official website: [www.fwheel.cc](http://www.fwheel.cc)





DYU Official Store Facebook Page Code