

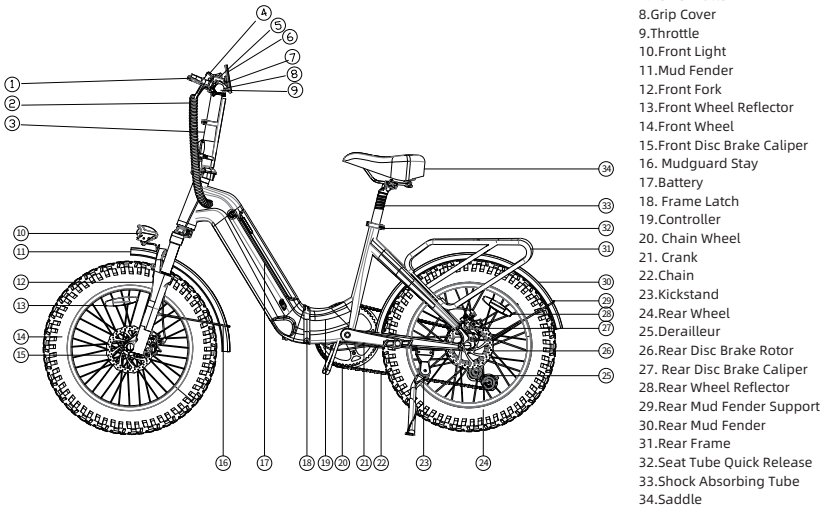

DYU SMART ELECTRIC BIKE FF500 INSTRUCTION

Do not use the eBike without reading this manual carefully and
knowing your eBike thoroughly
Please save this manual for future reference

PARTS & COMPONENTS



1. Brake lever
2. Wire
3. Folding Tube
4. Shifter
5. Bell
6. Display
7. Power Button
8. Grip Cover
9. Throttle
10. Front Light
11. Mud Fender
12. Front Fork
13. Front Wheel Reflector
14. Front Wheel
15. Front Disc Brake Caliper
16. Mudguard Stay
17. Battery
18. Frame Latch
19. Controller
20. Chain Wheel
21. Crank
22. Chain
23. Kickstand
24. Rear Wheel
25. Derailleur
26. Rear Disc Brake Rotor
27. Rear Disc Brake Caliper
28. Rear Wheel Reflector
29. Rear Mud Fender Support
30. Rear Mud Fender
31. Rear Frame
32. Seat Tube Quick Release
33. Shock Absorbing Tube
34. Saddle

Note: As we upgrade our eBikes, the one you own may be slightly different from the one shown above, but how you use it will be the same.

In the Package

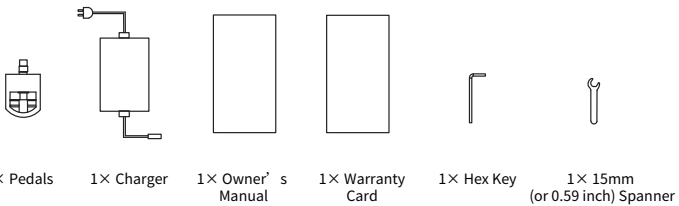

Battery Removal

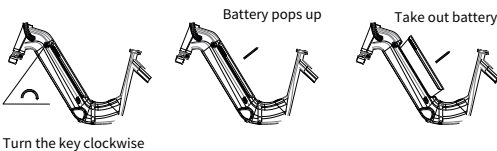

Installing the Pedals

Screw in the right pedal clockwise, and the left counter-clockwise.

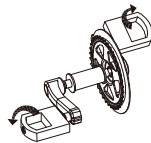

GETTING STARTED

1. Assembling: 1) Open the box, take out your eBike, and remove the packaging. 2) Mount the front wheel to the front fork, and tighten the screws to lock into place. 3) Assemble and align the handlebar upon the riser, and lock into place. 4) Walk the eBike to ensure no abnormal sound from the turning wheels. Gently pull the brake levers for a couple of times to ensure both the front and rear brakes function normally. 5) Adjust the seat tube to desired height, and lock the quick release. 6) Install the pedals and tighten up. (Please wear a helmet when riding the eBike.)

2. Charging: Connect the DC jack of the original charger to the charging slot of your eBike, and the AC plug to the mains. The charger light turns from red to green when charging is complete. (Please do not charge your eBike indoors. For outdoors charging, please avoid rain and strong direct sun over the charger.)

3. Power on and off: Locate the power button on the left handle. Press "M" to power on and the display shall turn on as well. Press again to power off.

4. Headlight: Locate the light switch at the left handle. When power is on, press "☰" button and hold it for three seconds to switch the headlight on and off.

5. Walking Mode: Locate the button "☺" at the left handle. Press and hold it for three seconds to activate the Walking Mode which maintains a riding speed of 6 km/h (or 3.73 mph). To disable the Walking Mode, press the button again, or pull the brake levers.

6. Shifting mode (motor speed): Locate the switch button on the left handle. Press "☰☺" shift the motor speed. Mode 1/2/3 corresponds to the motor-powered maximum speed of 15 km/h (or 9.32 mph), 25 km/h (or 15.53 mph) and 32 km/h (19.88 mph).

7. Display: The display in the center of the handlebar shows battery level, speed, mode, mileage, lights and failure report.

8. Riding modes:

a. Sports Mode: Power is off and there is no motor output. Pedal and exercise.

b. Throttle Mode: When the power is on, twist the throttle to accelerate and start the ride without pedaling.

c. Pedal Assist Mode: When the power is on and while you are pedaling, the motor also provides power for an easier and more energy-efficient ride.

9. Power cut-off brakes: When you pull the brake levers, the controller cuts off the motor output. The mechanical disc brakes are also engaged. As long as the brake levers are not completely released, Pedal Assist Mode or Throttle Mode remains disabled.

10. Removing and installing the battery: This battery is removable. To remove it, open the battery lock, turn the clip, pull downward to reveal the upper part of the battery first before pulling the entire battery out. To install the battery, start with the bottom of the battery, slide it in through the battery tube, push in the upper part, turn the clip, and lock the battery. (For battery replacement upon damage, please contact our official customer service.)

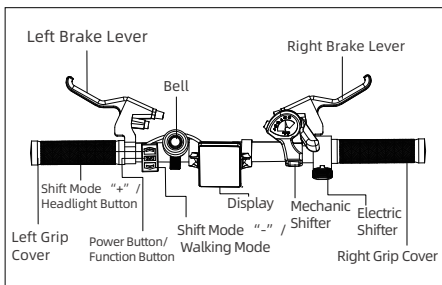
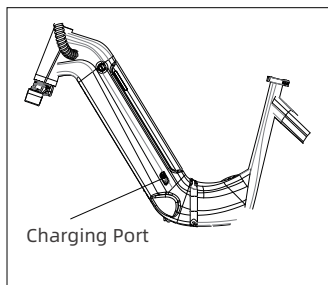

INSTALLING THE FRONT WHEEL

Installing the Front Wheel

I. Basic mechanical principle with the hub and anchor nuts

Turn the anchor nuts clockwise to increase clamping, and anti-clockwise to decrease.

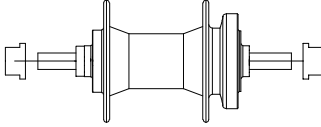

II. How to install

1. Manually turn the anchor nuts anti-clockwise to loosen for space, and insert the front wheel all the way into the dropouts of the front fork.

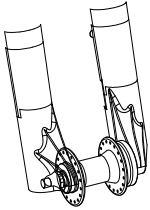

Correct

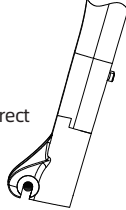

Wrong

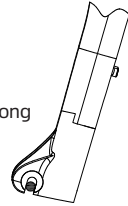

2. Manually turn the anchor nuts clockwise to fasten up. Ensure that the front wheel is located at the very center of the front fork, and that the disc brake rotor is parallel to the disc brake caliper towards the end of the front fork with space in between. Keep some space on both sides, and tighten into place with a spanner as indicated below.

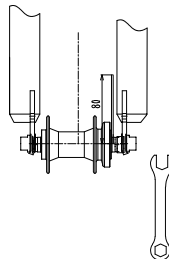
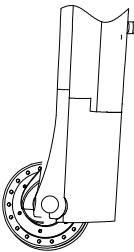

GEARS

Some DYU eBikes come with gears, which consists of:

- Rear sprocket cluster, called freewheel or cog set
- Rear derailleur
- Shifter
- Control cable
- Front sprocket, called chaining
- Drive chain

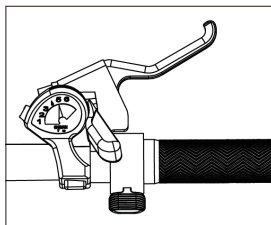

The gear mechanism differs in ergonomic design, performance and price.

A downshift is a shift to a lower or slower gear, which makes pedaling easier. An upshift is a shift to a higher or faster gear, which makes pedaling harder. In practice, you can upshift to go faster, and you can downshift to go uphill.

A shift is possible only when you are pedaling forward, i.e. the drive chain is moving forward and under some tension.

CAUTION

Never shift when pedaling backward. Also, do not pedal backwards after a shift. Either action may jam the chain and cause serious damage to your eBike.

DERAILLEUR SYSTEM

The derailleur system includes front and rear derailleurs, shift levers, and derailleur control cables. For smooth shifting, all components must function properly.

Although the front and rear derailleurs are initially adjusted in the factory, you need to inspect them before each ride.





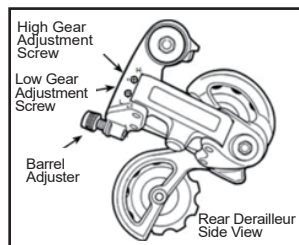
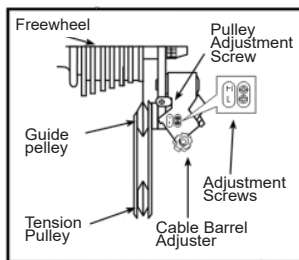

To begin, twist the shifter to the largest number indicated, and the cable shall loosen the anchor bolt on the rear derailleur, placing the chain on the smallest sprocket.

Adjust the high limit screw so that the guide pulley and the smallest sprocket are lined up vertically. Re-tighten the cable, pull out any slack, and re-tighten the anchor bolt securely. Shifting through the gears, making sure that each gear is achieved quietly and swiftly.

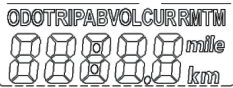

If necessary, use the barrel adjuster to fine tune the cable tension by turning it the direction you want the chain to go. For example, turning clockwise loosens cable tension and moves the chain away from the wheel, while turning counter-clockwise tightens cable tension and direct the chain towards the wheel.

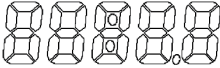

DISPLAY

<p>Display Sample</p>		
Item	Image	Description
<p>Headlight</p>		<p>The icon lights up when the headlight is on, and off when the headlight is off.</p>
<p>Multi-functions Display</p>		<p>Total mileage Mileage of a single ride Battery voltage Working current Time lapse</p>
<p>Current speed</p>		<p>Current speed</p>
<p>Current mode</p>		<p>Walking Mode Cruising Riding modes</p>
<p>Current battery level</p>		<p>Current battery level</p>
<p>Failures</p>		<p>E02: Abnormal braking E06: Battery undervoltage E07: Motor failure E08: Throttle failure E09: Controller failure E10, E11: Abnormal communication</p>

BUTTONS

Item	Image	Description
"M" button		Power on/off when press up to three seconds
Up button		Press to gear up, and hold to turn the headlight on and off.
Down button		Press to gear down, and hold to activate the Walking Mode.

Display Setting

Press and hold both the Up and Down buttons at the same time to open the setting menu. Once on the menu, press the Up or Down button to respectively increase or decrease the value. Press M button to shift the value.

To save a setting and exit the setting menu, press and hold both the Up and Down buttons at the same time. The setting times out and saves automatically after eight seconds of inactivity.

P01 is for the brightness of the display, which increases from level 1 to level 3.

P02 is for the unit of mileage, with 0 for km and 1 for mile.

P16 is to clear mileage. Press and hold the Up button for ten seconds to set the mileage back to zero.

SPECIFICATION

	Model	FF500
Build	Body material	Aluminum alloy
	Expanded size	1760*585*1270 mm (or 69.29*23.03*50 inches)
	Packing size	1515*310*720 mm (or 59.65*12.20*28.35 inches)
	Wheelbase	1150 mm (45.28 inches)
	Pedal ground clearance	120 mm (or 4.72 inches)
	Wheel hub	16 inches
	Body Color	Blue
Performance	Weight	31 kg (or 68.34 lbs.)
	Load	75kg (or 165 lbs.)
	Average speed	25 km/h (or 15.53 mph)
	Max design speed	32 km/h (or 19.88 mph)
	Power consumption per hundred kilometers	1.08 kWh
	Range in throttle mode	55±5 km (or 34.18±1.86 mi)
	Range in pedal assist mode	65±5 km (or 40.39±3.11 mi)
	Hill climbing capacity	15 degrees
	Operating temperature	-10~45 degrees Celsius (or 14-113 degrees Fahrenheit)
	IP rating	IP54

SPECIFICATION

Core	Model	FF500
	Battery type	18650 lithium-ion
	Battery capacity	14Ah
	Battery rated voltage	48V
	Charging voltage	DC54.6V
	Charger input voltage	AC100-220V
	Charging time	7-8 hours
	Motor type	In-wheel high speed motor
	Motor rated power	500W
	Motor rated speed	340 r/min
	Motor rated voltage	48V
	Controller under voltage value	41V±1V
	Controller over current value	18A
Features	Headlight	Yes
	Rear light	Yes
	Cruise	Yes
	Speed sensor	Yes
	Adjustable seat height	Yes
	Braking	Front and rear disc brakes
	Customized stickers	Optional

Note: The max speed may vary, depending on the battery level, load, tire pressure, terrain, lubrication state of the chain and bearings, etc. The ranges are determined upon tests at the ambient temperature of 25°C (or 77°F), at the speed of 15 to 20 km/h (or 9.32 to 12.43 mph), on smooth and firm terrain, with a load of 75 kg (or 165.35 lbs.), and within an uninterrupted period from full to zero battery level. The ranges may vary, depending on your riding behavior, ambient temperature, load, tire pressure, terrain, etc.

CIRCUIT DIAGRAM

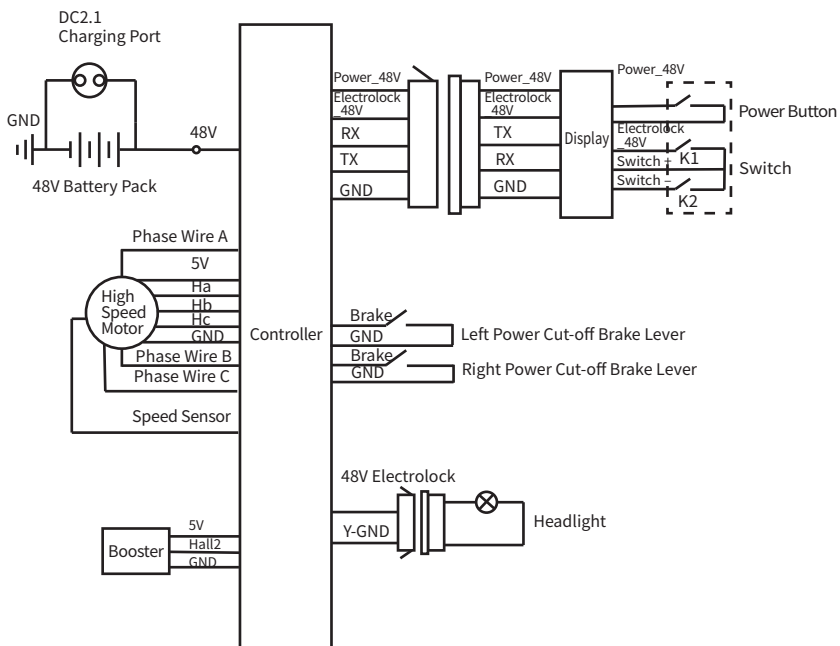

ATTENTION

Battery & Charging

- Do not connect the positive to negative, or vice versa. Do not damage, disassemble, or short-circuit the battery. Avoid water, other liquid, or other foreign matter inside the battery to prevent short circuit.
- Instructions in this manual must be followed when charging the battery, otherwise the owner shall take sole responsibility for any consequences.
- Charge the battery only at the temperature between 0°C (or 32°F) and 45°C (or 113°F), and discharge at the temperature between -20°C (or -4°F) and 60°C (or 140°F). The charging current should not exceed 2A. Charge only in a well-ventilated area, away from sun and heat.
- Use the original charger from the package to charge the battery. Connect the charger and battery before plugging the charger into the mains. Do not charge the battery for over 6 hours each time.
- When charging, if the charging indicator appears abnormal, a smell is released, or the charger overheats, stop charging immediately. Service or replace the charger.
- To stop charging, unplug from the mains before disconnecting the charger and battery.
- When the charging indicator turns green, stop charging.
- Do not leave the charger connected to any AC power source when not charging.
- When not in use, store the battery in a dry (relative humidity at 65±20%) and cool (temperature at 10-35°C, or 50-95°F) place. Keep away from fire, heat and high temperature. Do not put the battery in acid or alkaline liquid. Make sure to charge the battery for two hours each month.
- Before using the charger to charge a different battery, note the battery type and voltage that the charger may apply to.
- It is advisable not to carry the charger with your eBike. If you must, place the charger in a toolbox upon shock absorption treatment.
- Do not disassemble the charger or replace the parts and components in the charger on your own.
- Waste battery is classified as hazardous. Do not disassemble the waste battery on your own. It should be collected and recycled properly.

Riding your eBike

- Do not use the eBike before reading this manual carefully and knowing your eBike thoroughly.
- **This eBike is designed for riders aged 16-45. Anyone aged below 16 is strictly forbidden to ride this eBike.**
- **Please wear a helmet.**
- Do not lend your eBike to anyone who do not know how to use it, so as to avoid harm.
- When adjusting the steerer tube and seat tube, do not expose the minimum insertion marks.
- Before riding, check the tire pressure. It is advisable to maintain at 35-45 PSI.
- Before riding, ensure the power, lights, handles, brakes, wheels, reflectors and others are in good condition.
- Before carrying people or objects on your eBike, learn the local laws and regulations, and abide by them.
- Do not exceed the load capacity of 120 kg (or 264.60 lbs.).
- Wear a helmet, and obey traffic rules.
- Obey local traffic rules to keep to the right or left.
- Do not ride on any motorized lane or in any pedestrian crowd.

ATTENTION

- It is advisable not to go over 15 km/h (or 9.32 mph) when riding on any non-motorized lane, downhill, or paved road.
- Slow down in rain or snow as required braking distances increase.
- It is advisable not to ride in storms or any extreme weather.
- Avoid impact on the motor.
- Keep the bearings lubricated.
- Do not park your eBike in any lobby, walkway, evacuation stairway, or emergency entrance/exit.
- Do not charge or park your eBike inside any residential building. Keep away from combustibles when charging. Charging should not exceed 6 hours each time.

Maintenance

- The front and rear wheels should be aligned to the center of the front fork and frame.
- Park away from direct sunlight and rain.
- Do not rinse the eBike. Wipe with a damp cloth to clean.
- Check the motor and brakes frequently. Do not oil the braking system.
- Regularly check all screws and keep them fastened.
- Recommended torque specs: handlebar screw 60-80 kgf.cm (or 52.08-69.44 lbf.in), steering stem screw 175-200 kgf.cm (or 151.90-173.60 lbf.in), saddle screw 175-250 kgf.cm (or 151.90-217.00 lbf.in), and wheel screw 320-450 kgf.cm (or 277.70-390.60 lbf.in).
- Regularly check the tension of the chain, which can be adjusted via the chain regulator.
- Frequently check the tires for scratches, cracks or excessive wear. The inner tube and valve should be perpendicular to the wheel hub. Punctured, damaged or excessively worn inner tube and tire must be replaced immediately. Please contact professional technicians.
- It is forbidden to modify key structural parts including the frame, front fork and steerer tube, and any electrical parts. If damaged, replace with identical parts from our factory. Otherwise, the warranty shall be void and the owner shall take sole responsibility for any consequence.

Disclaimer

- Our company reserves the right to modify and give final interpretation to the product model, specification, and other information contained in this manual.
- The functions of the specific model referred to in this manual apply to this specific model only.
- The product model, specification, and other information contained in this manual is subject to any modification or change without notice.
- Without the prior written permission of the company, the contents of the manual may not be copied, modified, reprinted, disseminated or published in any form.
- Please read this manual carefully before using the product, and operate in accordance with the manual. Otherwise, the company shall not be liable for any personal or property damage, including damage to the product, caused by misuse or abuse.
- For more information, please visit our official website: www.dyucycle.com.



DYU Ebike Owners Group